

ASSEMBLY INSTRUCTIONS CABINET HARDY

zuiver^o

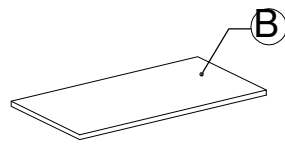
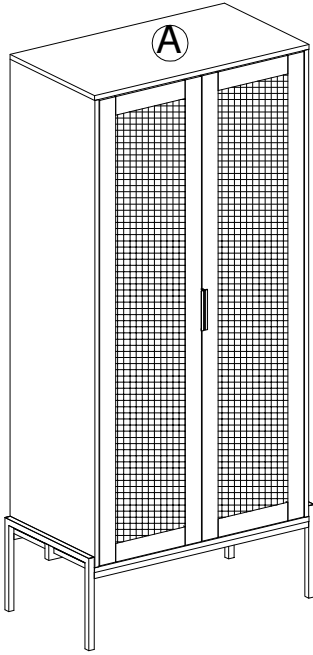

Parts Check List

Code	Components	Qty
(A)	BODY	x01
(B)	SHELF	x02

Hardware Check List

code	description	qty
01	Metal bracket	x04
02	Screw	x04
03	Plastic strap	x02
04	Nylon wall strap	x02

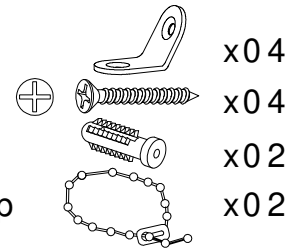

-PLEASE DO NOT DISCARD ANY OF THE PACKAGING UNTIL YOU HAVE CHECKED ALL THE PARTS AND THE PACKS OF HARDWARE.
 -BEFORE YOU BEGIN TO ASSEMBLE YOUR NEW PIECE OF FURNITURE, PLEASE CHECK TO ENSURE THAT ALL PARTS HAVE BEEN SUPPLIED.
 -FOLLOW INSTRUCTIONS CLOSELY AS DEVIATION FROM THEM MAY VOID YOUR WARRANTY AND PRESENT A POSSIBLE SAFETY RISK.
 -IT IS RECOMMENDED THAT ASSEMBLY IS DONE ON A SOFT SURFACE LIKE CARPET TO AVOID ANY DAMAGE.
 -PERIODICALLY CHECK AND RE-TIGHTEN ANY FASTENERS. WIPE DOWN ALL SURFACES WEEKLY WITH A CLEAN CLOTH. DO NOT CLEAN ANY SURFACES WITH HARSH ABRASIVES OR CHEMICALS.

Tools required
Not supplied

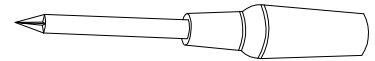

1.

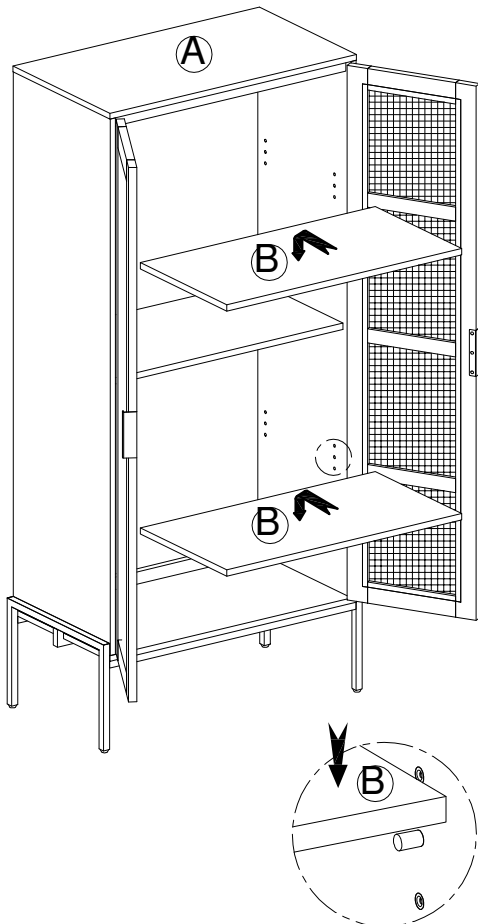

2.

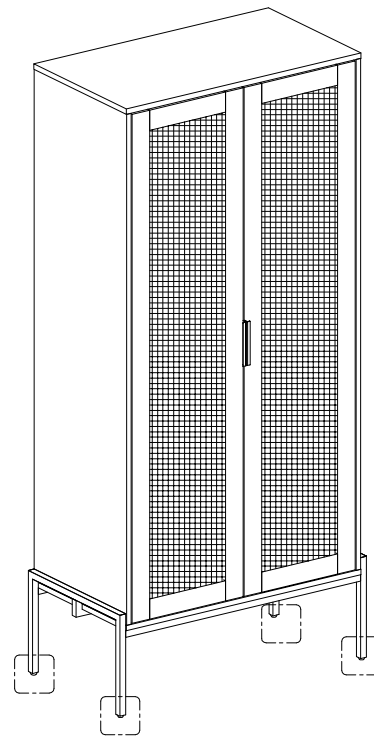

3.

Back view

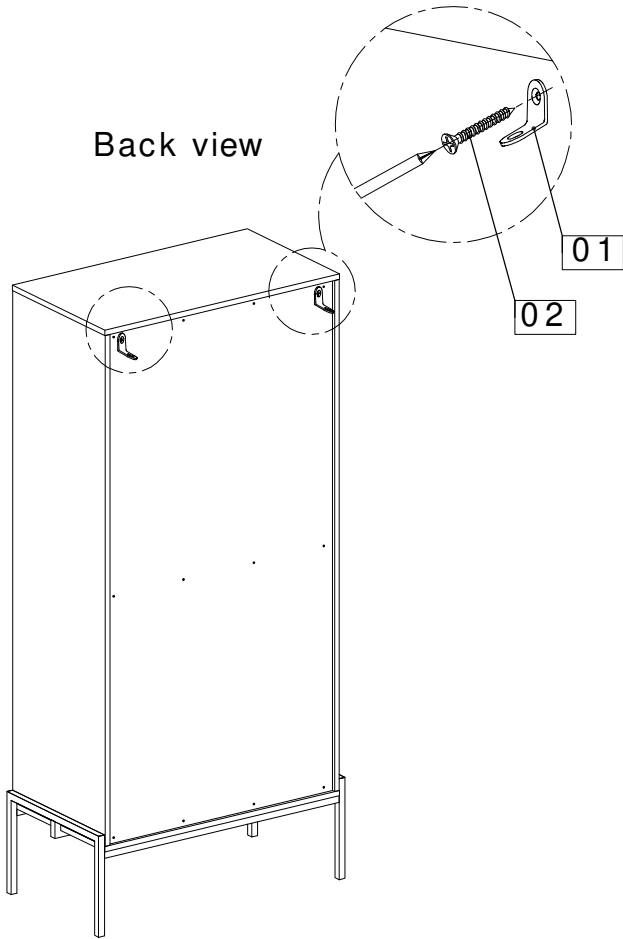

4.

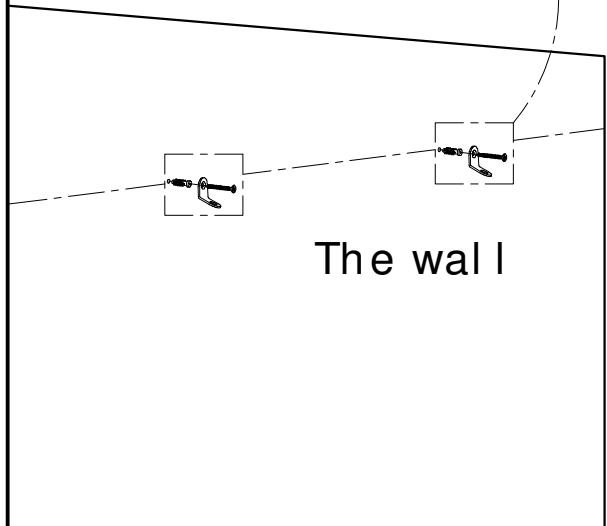
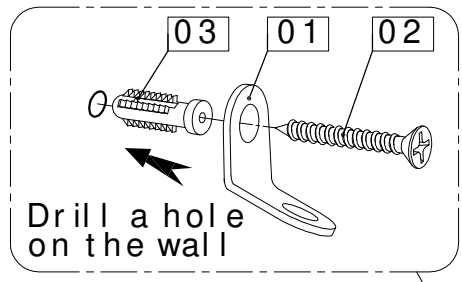

5.

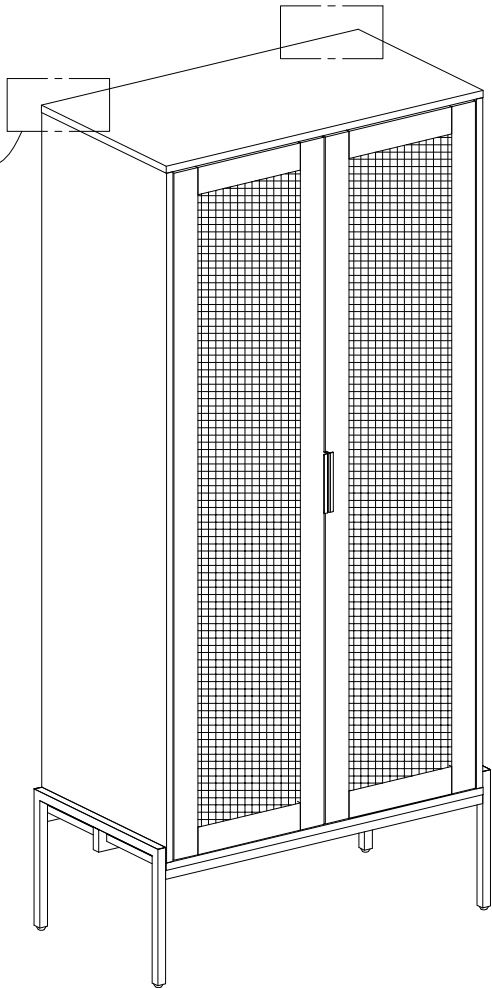
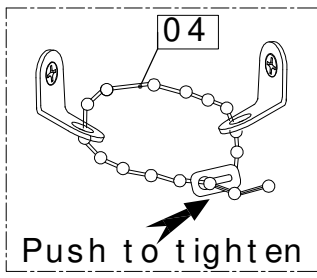

ASSEMBLY INSTRUCTIONS HINGE ADJUSTMENT

ZUIVER^o

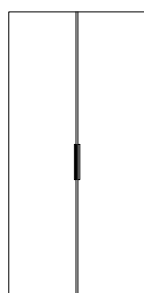
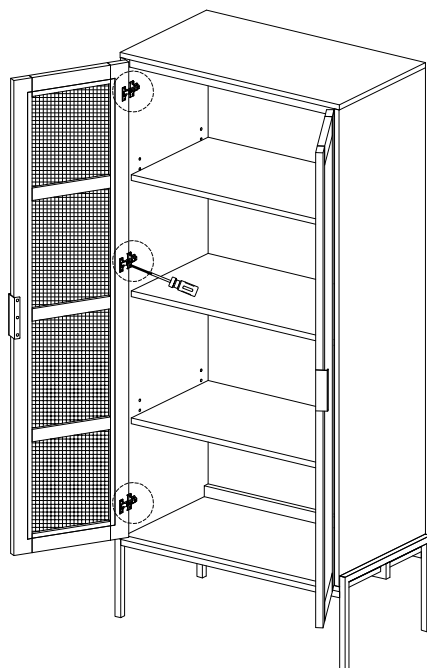

The door will not be flush with the side panel.

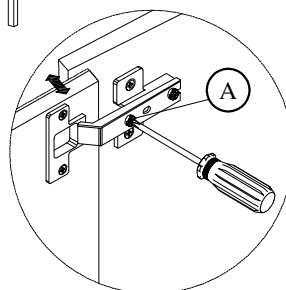

Side to Side Adjustment
loosen screw A, adjust gap with screw B and re-tighten Screw A.

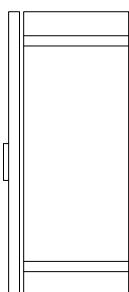

The door will appear too far or too close from the front edge of the side panel.

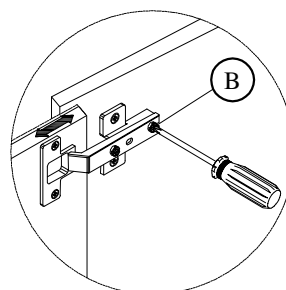

Depth Adjustment
loosen screw A, push hinge arm forwards or backwards, re-tighten screw A and secure Screw B with a 1/4 turn clockwise.

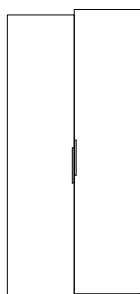

The door will not be flush with the vertical panel.

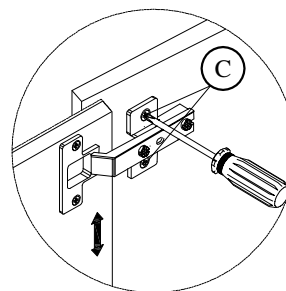

Height Adjustment
loosen screw C, adjust door height and re-tighten screw C.

* The doors can be adjusted in all 3 directions to create an even fit between doors on this cabinet. Follow the appropriate directions above to adjust door(s) as necessary.