

**Product datasheet active earmuff****uvex aXess one**

safe. active. connected

**PPE-Category III - harmful noise****Product characteristics:**

- Active Bluetooth® earmuff with RAL-Function
- RAL (Real-Active-Listening), enables the perception of ambient noise and communication at close range
- Bluetooth® 5.2, good sound quality, fast data transfer, large range and optimized power consumption
- Integrated sound level limiter
- Dual connection mode, can be paired with two Bluetooth devices at the same time
- Hands-free telephony, telephone calls without interrupting your work
- Direct operation of the connected phone on the earmuff, the device remains in a protected environment
- Audio assistant, to hear the operating status in the earmuff, no need to remove the earmuff in hazardous areas.
- External audio input, for devices without Bluetooth®

- Charging socket USB Type-C, fast charging, and easy handling thanks to symmetrical plug
- LED operation status light
- LED charging light
- Two surround microphones, for reliable transmission of ambient noise
- Extra voice microphone, to ensure optimal voice quality
- Two 40mm speakers for good sound quality
- Integrated socket covers
- IP54 Water and dust protected ideal also for outdoor locations
- Shaped function keys, they are easy to feel and can also be operated when wearing gloves
- Sealing cushion made of memory foam for a good seal and fit to the head
- Padded comfort headband with memory foam for a comfortable feel
- Microphone foam covers, to reduce the wind noise and protect the microphones
- Foldable headband small and handy stowable, also ideal the earmuff bag with belt loops art.no. 2000002. (Accessories)

### **Approval:**

The product complies with the harmonized standards EN 352-1:2020, EN 352-4, EN 352-6, EN 352-8, ANSI S-3.19-1974, CSA Z94.2-02 and AS/NZS 1270:2002 and meets the requirements of the PPE Regulation (EU) 2016/425 and the 2014/53/EU, RED 2014/53/EU and FCC Directives.

The applicable jurisdiction can be found in the Declaration of Conformity here:

[uvex-safety.com/ce](http://uvex-safety.com/ce)

or for the UK at [uvex-safety.co.uk/en/media/uk-declarations-of-conformity/](http://uvex-safety.co.uk/en/media/uk-declarations-of-conformity/)

The PPE is subject to the following conformity assessment procedures: Conformity to type based on quality assurance related to the production process (Module D) and controlled by:

BSI Group The Netherlands B.V.

Say Building, John M. Keynesplein 9

1066 EP, Amsterdam

Netherlands

Notified body No. 2797

### **Bluetooth License:**

The Bluetooth® word mark and logos are registered trademarks owned by Bluetooth SIG, Inc. and any use of such marks by UVEX ARBEITSSCHUTZ GMBH is under license. Other trademarks and trade names are those of their respective owners.”

### **Materials:**

Cups:	ABS
Headband:	Stainless steel / PVC / PE-Memory foam
Sealing cushion:	PVC / PE-Memory foam
Cup foam:	PE

**Technical data:**

Weight: 364g  
Size: S / M / L  
Operating voltage: 5 V USB type C  
Input: 5V  $\approx$  1A  
Battery: 3.7 V lithium-polymer battery, 750 mA  
Battery charging time: 2.5 hours  
Battery operation time: 50 hours  
Audio input: 3.5mm jack plug  
Operation temperature: -10 to + 55°C

Bluetooth® 5.2 Supported profiles: A2DP, AVRCP, HSP, HFP

## Attenuation values:

Tested according to European Standard EN 352-1:2020



SNR: 31dB

HML: 37dB – 29dB – 21dB

Freq. Hz	63	125	250	500	1000	2000	4000	8000	H	M	L	SNR
Mean att. dB	18.8	16.3	21.0	27.3	37.1	37.8	44.2	43.2	39.1	30.3	22.8	32.8
Std. dev. dB	2.9	2.5	1.7	2.5	2.3	2.9	4.2	4.4	2.3	1.7	1.9	1.7
APV	15.9	13.7	19.2	24.9	34.8	35.0	40.0	38.8	37	29	21	31

EN 352-4: Level dependence H= 115 dB, M= 104dB, L= 87 dB

EN 352-6: 82dBA criterion levels = -4,6dBV or 587.2mV

Tested according to Australian Standard AS/NZS 1270:2002

SLC80: 27dB

Class 5

Clamping force: 11.1N, 10.2N, 10.7N

Freq. Hz	125	250	500	1000	2000	4000	8000
Mean att. dB	14.8	16.3	23.5	33.1	34.3	41.4	40.1
Std. dev. dB	3.5	3.3	3.7	3.5	3.4	5.6	4.2
APV	11.3	13.0	19.8	29.6	30.9	35.8	35.9



AS/NZS 1270  
Lic. 41199  
SAI Global

Hearing protector class 5 tested to AS/NZS 1270. When selected, used and maintained as specified in AS/NZS 1269, this protector may be used in noise up to 110dB(A) assuming an 85 dB(A) criterion. A lower criterion may require a higher protector class.

Tested according to American Standard ANSI S-3.19-1974

NRR: 23dB

CSA Class A

Headband Force: lbs. 2.5

Freq. Hz	125	250	500	1000	2000	4000	8000
Mean att. dB	14.8	16.3	23.5	33.1	34.3	41.4	40.1
Std. dev. dB	3.5	3.3	3.7	3.5	3.4	5.6	4.2
APV	11.3	13.0	19.8	29.6	30.9	35.8	35.9

Test Institute, Michael & Associates, Inc., 2766 W. College Ave Suite 1, State College, PA 16801

Freq. - frequency

Mean att. – mean attenuation

Std. dev. – standard deviation

APV – assumed protection value

SNR – single number rating

H – attenuation value at high frequency

M - attenuation value at medium frequency

L - attenuation value at low frequency

### Scope of delivery:

- Active earmuffs uvex aXess one, with built-in rechargeable battery
- Quick-start guide
- Instruction for use
- USB- charging cable
- Audio cable with 3,5mm jack plug
- Microphone covers (3 pcs)

### Variants/Color:

Article-No.	Color	Packaging unit
2640.001	black matt / grey	1 piece

### Accessories:

Article-No.	Name	Packaging unit
2599971	Hygiene kit	1 kit
2599978	Comfort pads	10 pads in a pouch
2592640	Microphone cover	9 pcs in a pouch

### Storage:

Storage location: Store in the original packaging, in a dry, clean environment that is protected against light, UV and heat, at a temperature of between -10°C and 55°C and humidity of max. 85%.

Storage life: 5 years from date of manufacture. See product or packaging for date of manufacture. Ensure that when stored the headband is not extended and the sealing pads are not compressed. The battery must be charged occasionally if the earmuffs are stored for a longer period of time.

### Useful life:

Useful life of 5 years from date of manufacture. Dispose of the product once it has expired or immediately if it is damaged or can no longer be cleaned.

### Disposal:

This product is regulated by the Waste Electrical and Electronic Equipment (WEEE) Directive 2012/19/EU. Do not dispose of with normal household waste. The batteries must be disposed of in accordance with national regulations. Dispose of correctly at an official recycling centre.



**CAUTION!** Risk of explosion! Do not dispose of the product in fire.

**Logistic information:**

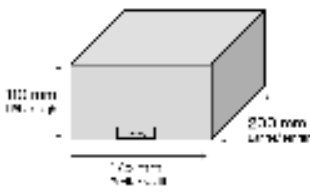
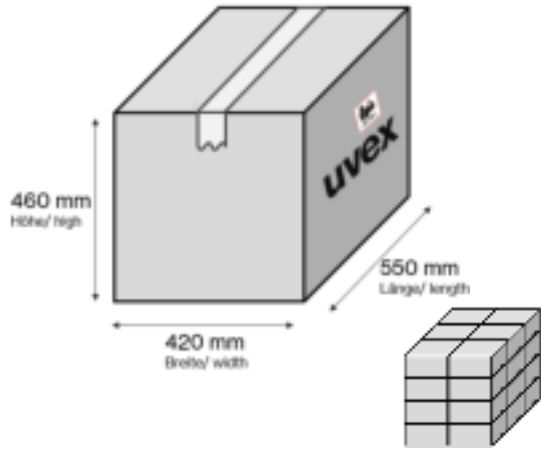
	<b>Sales unit</b>	<b>Outer packaging</b>
Order quantity	1 piece	1 piece
EAN-Code	4031101928913	4031101929026
Quantity in piece	1	24
		
Dimensions (l*w*h)	200mm x 175mm x 110mm	550mm x 420mm x 460mm
Packaging material	Cardboard box	Corrugated cardboard
Volume	3.85 dm <sup>3</sup>	106.26 dm <sup>3</sup>
Net weight	398 g	14 kg
Gross weight	585 g	16.4 kg
Shipping marking	UN 3481	

**UVEX ARBEITSSCHUTZ GMBH**  
**Wuerzburger Str. 181-189**  
**90766 Fuerth, GERMANY**  
**T: +49 (0) 911 97 36 0**  
**E: serviceteam@uvex.de**  
**I: uvex-safety.de**