



MAGNA3



net.grundfos.com/qr/i/98091805

be
think
innovate

GRUNDFOS 



MAGNA3



MAGNA3 D





Min./Max.
-10 °C – +110 °C

PN 6:6 bar / 0.6 MPa
PN 10:10 bar / 1.0 MPa
PN 16:16 bar / 1.6 MPa



Min./Max.
0 °C – +40 °C

< 55 dB(A)

Max. 95 % RH
IPX4D



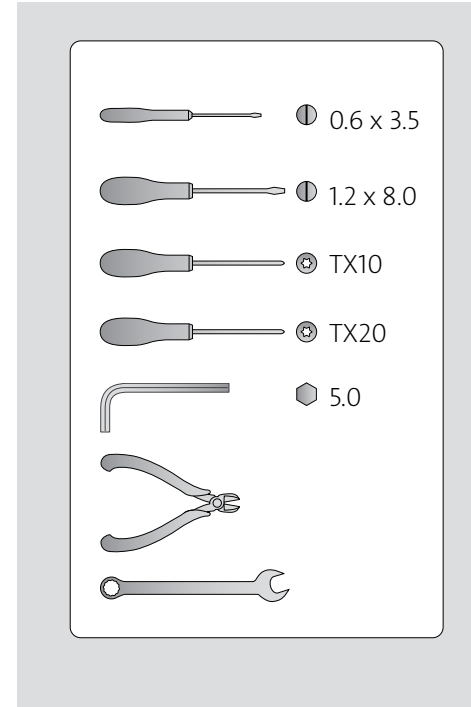
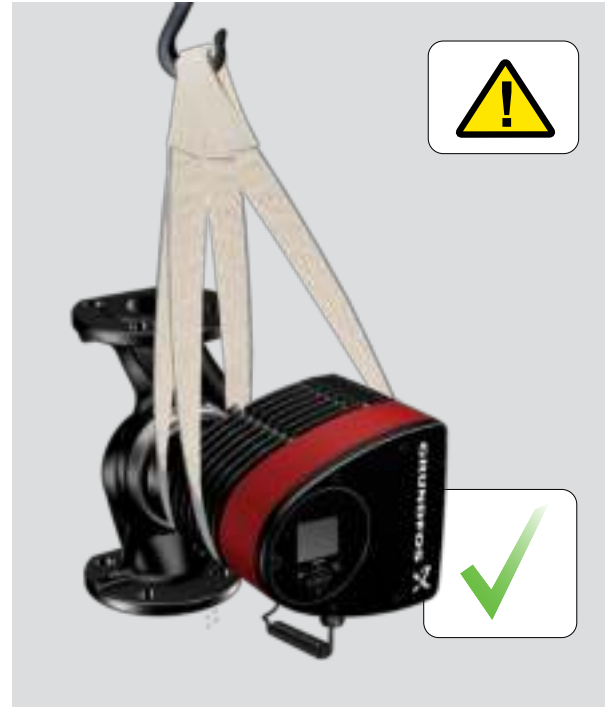

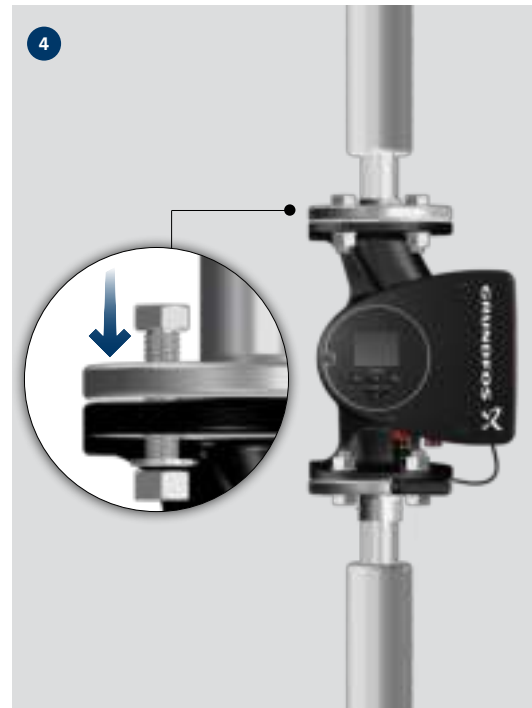
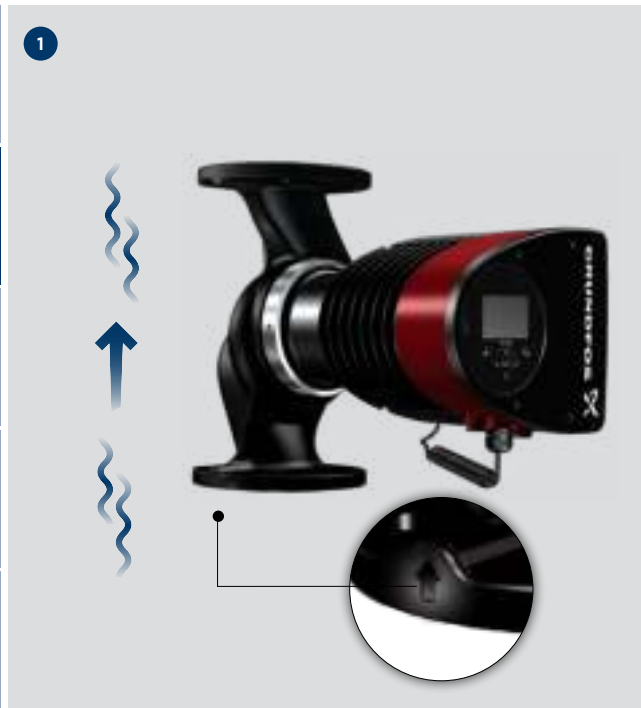

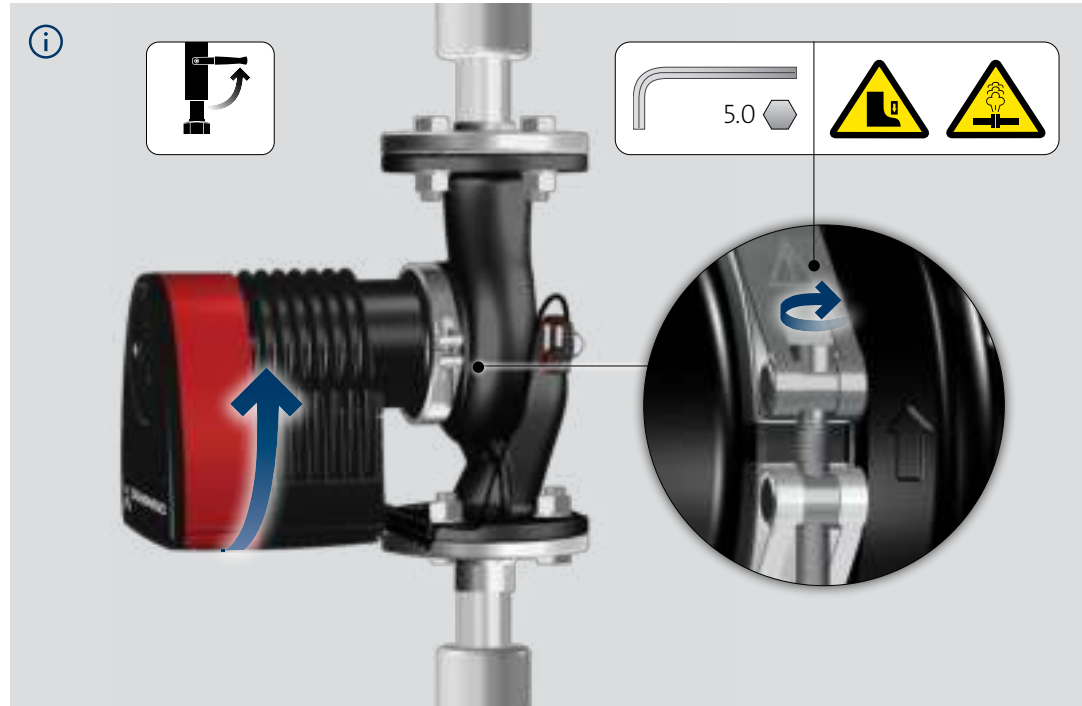

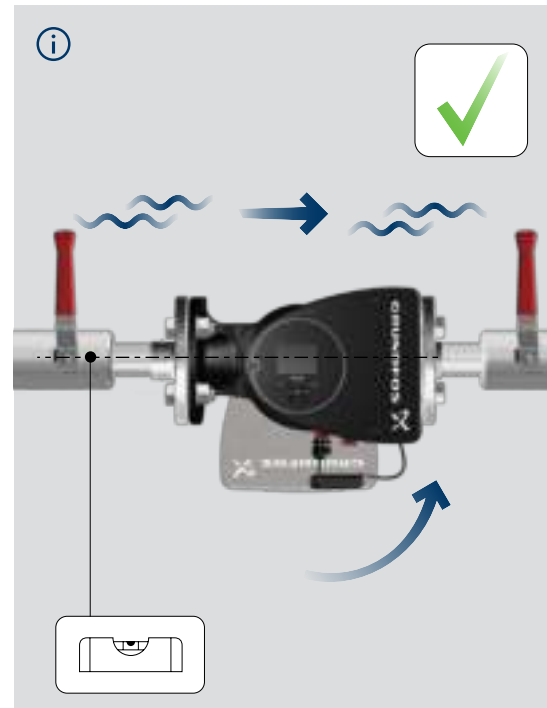
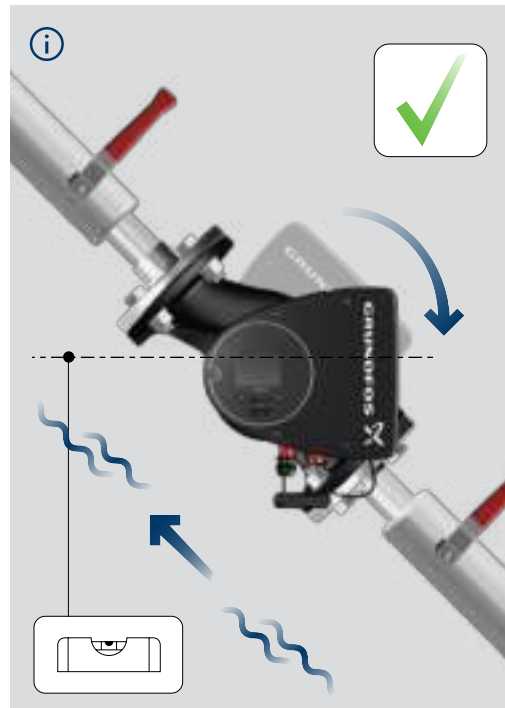
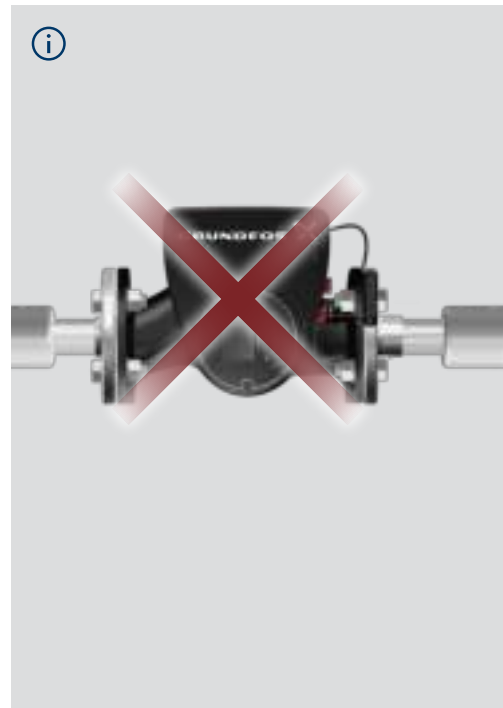
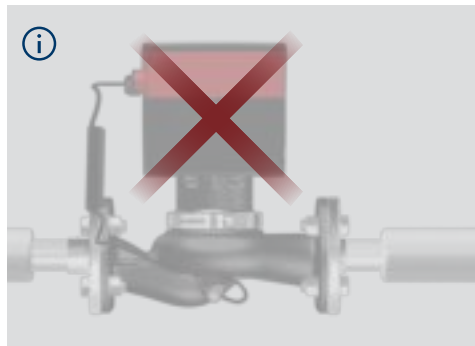

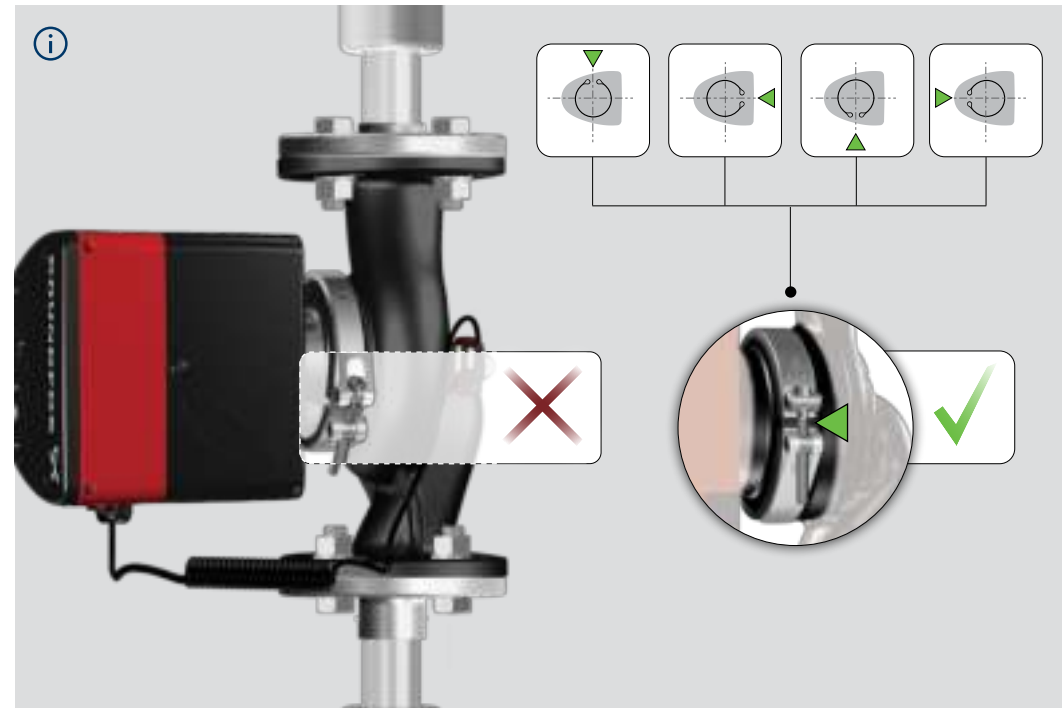
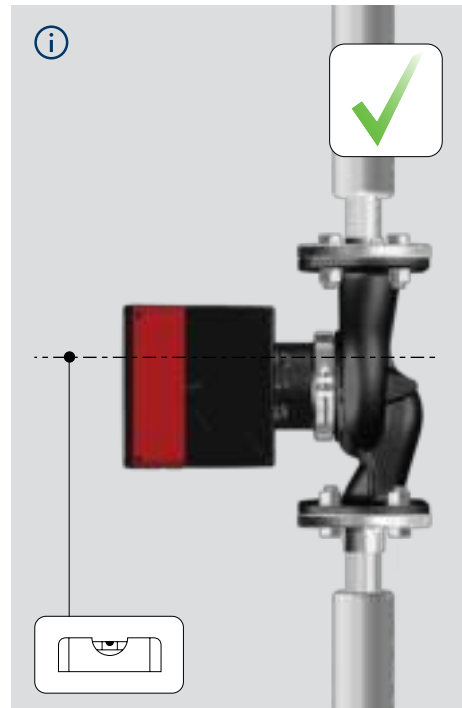
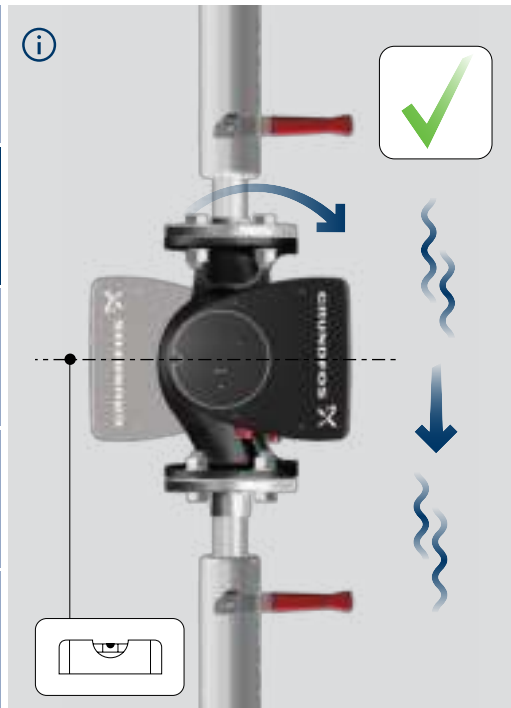

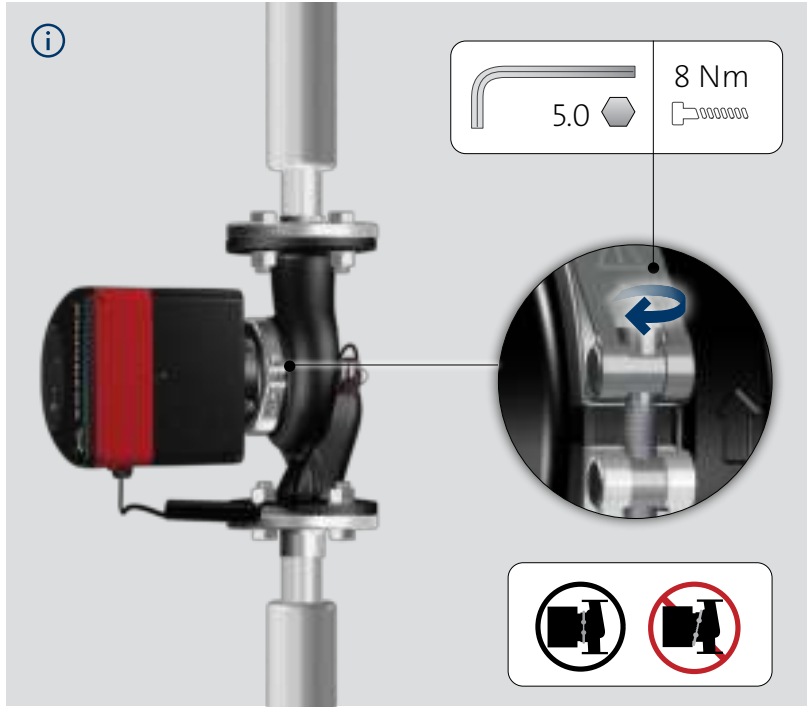



7

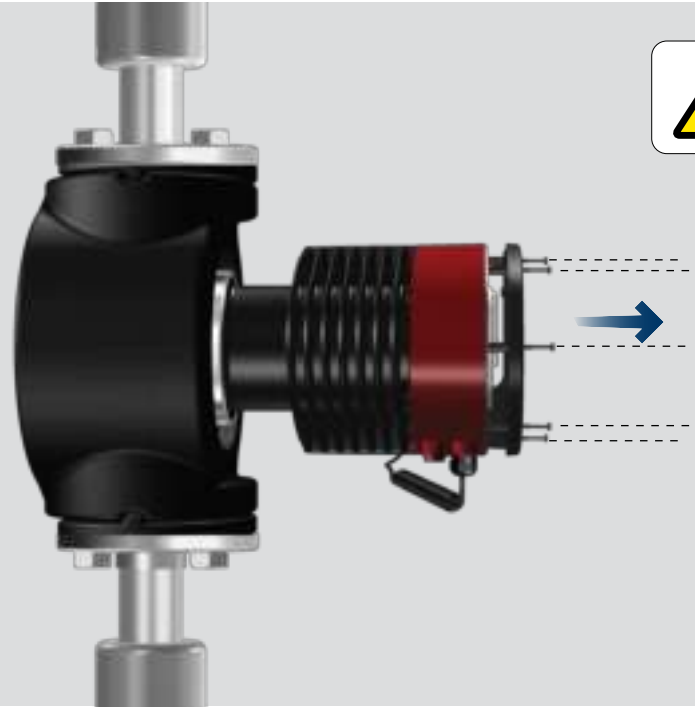

8

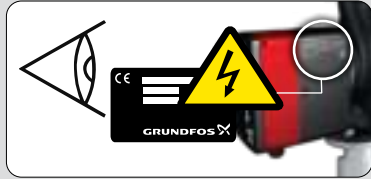

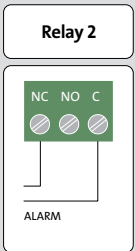
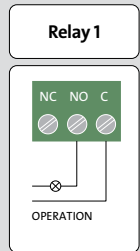
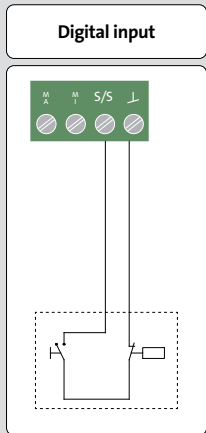
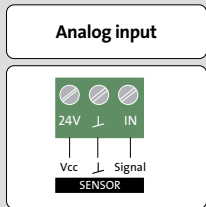

Use C and NC for fault signals as this enables serial connections of more relays and detection of signal cable defects.

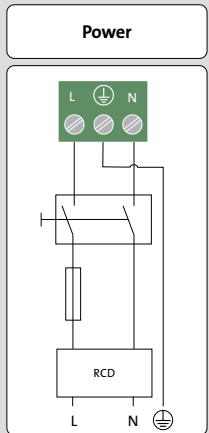

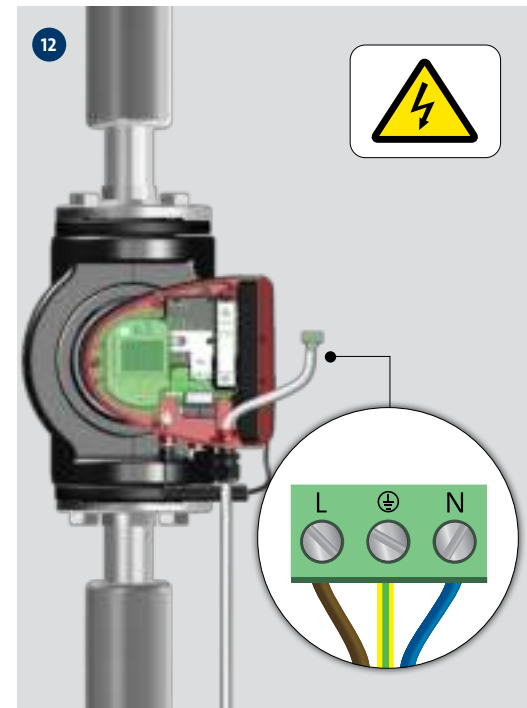
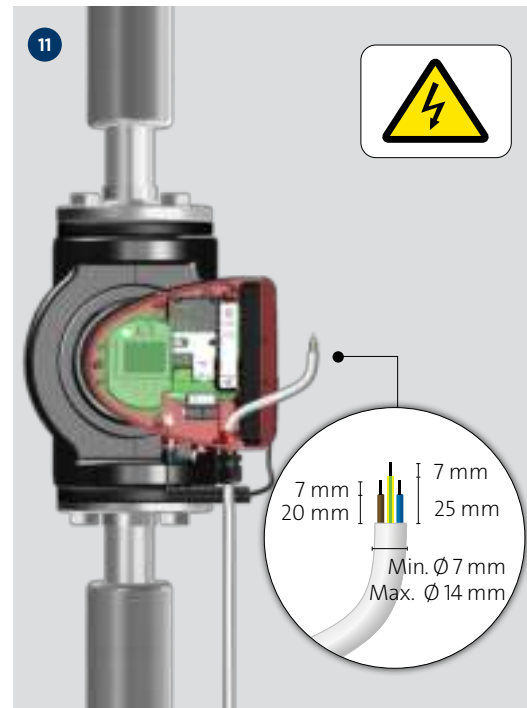
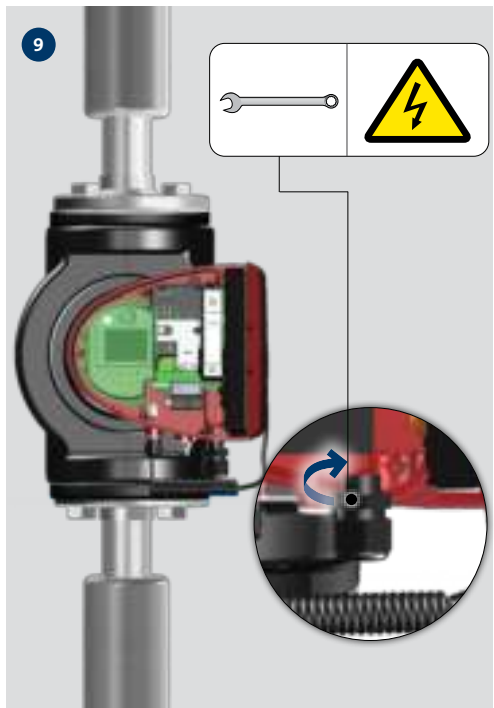



13

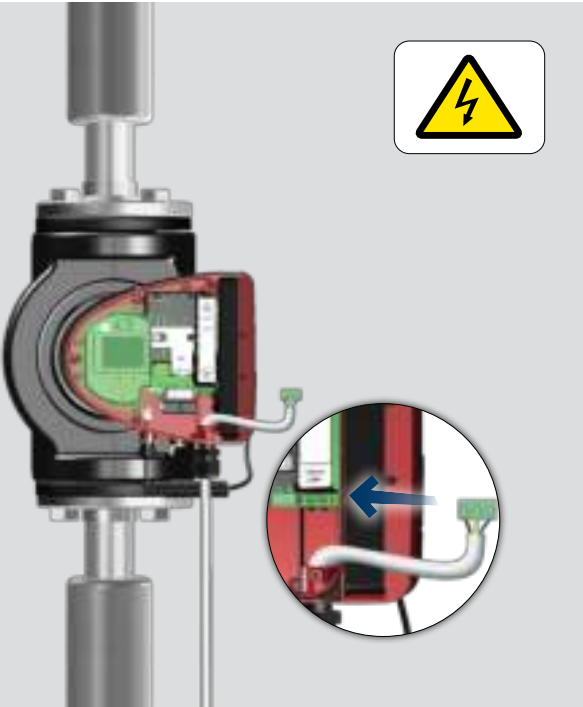

14

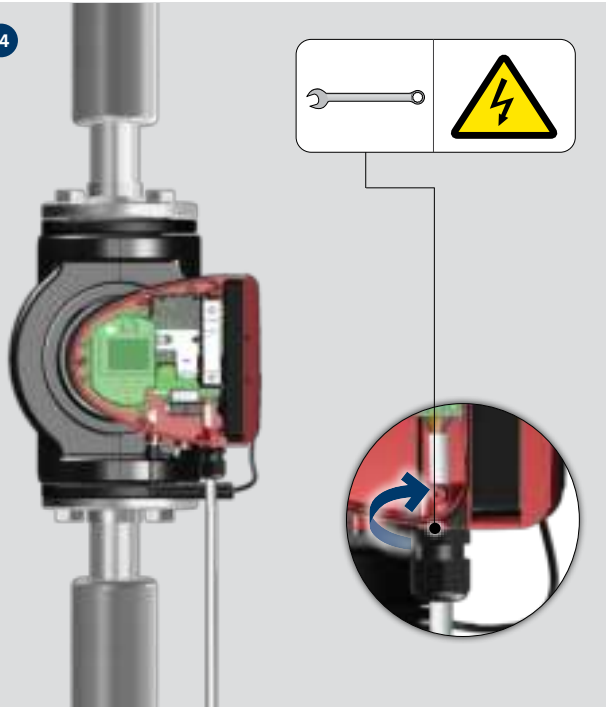
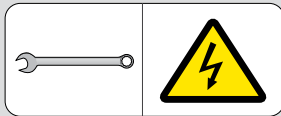

15

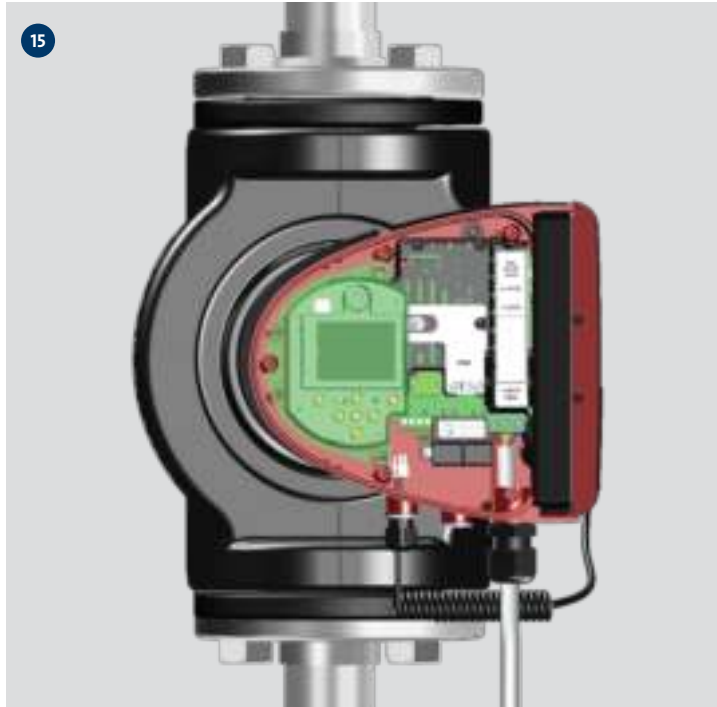



16

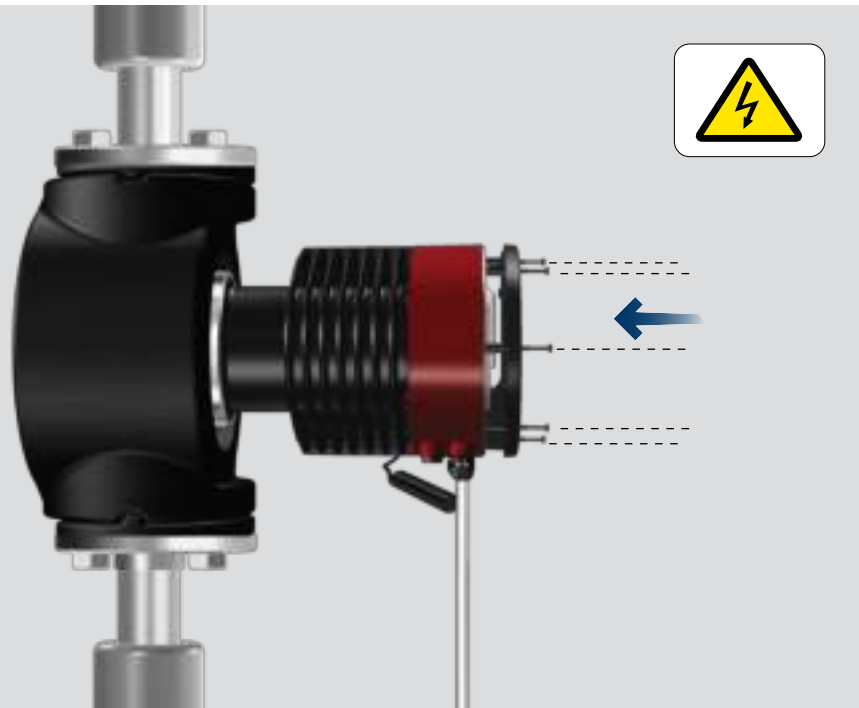

17

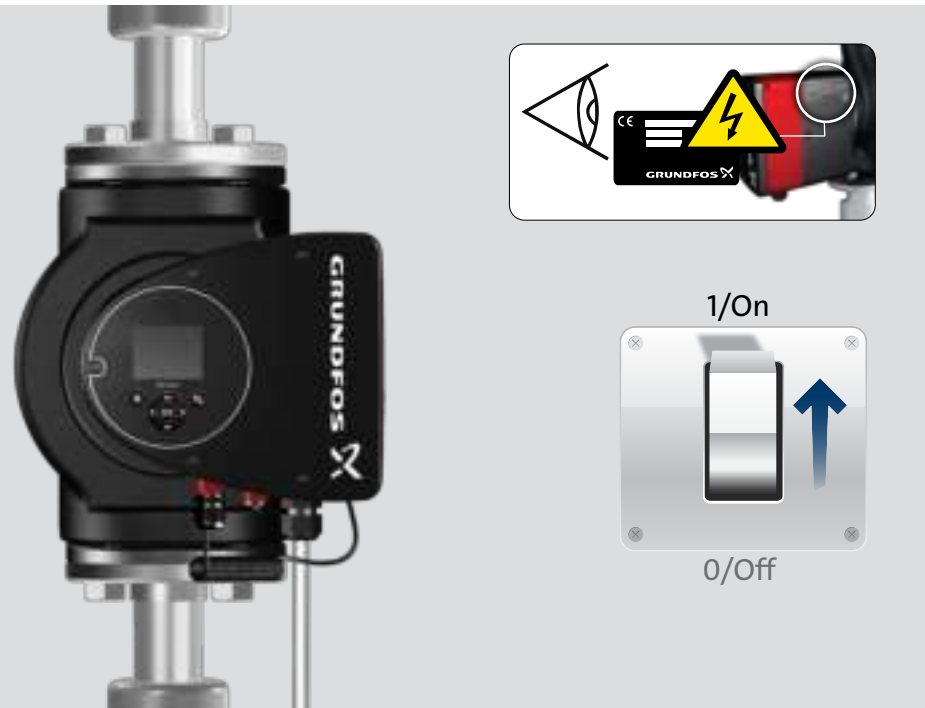



18



Power cycle

Max. 4 starts
per 60 minutes



19

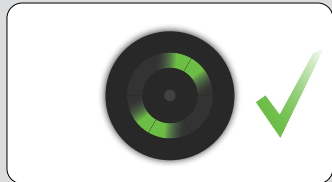

Further product documentation



net.grundfos.com/qr/i/98091805



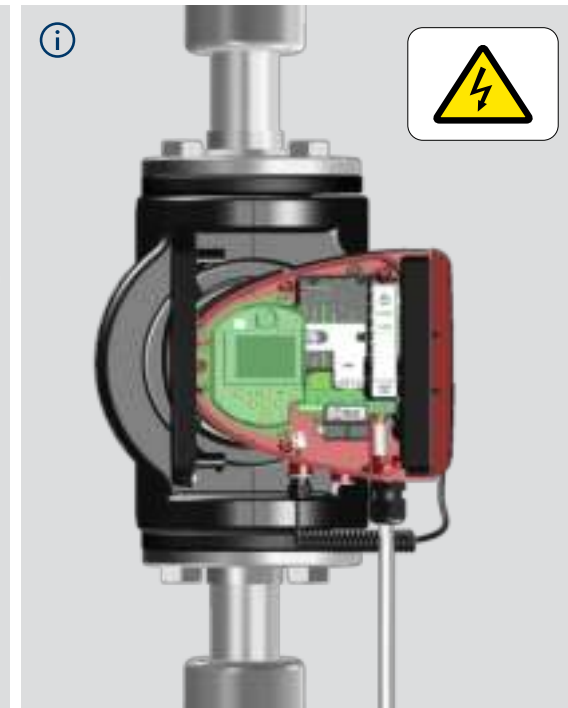
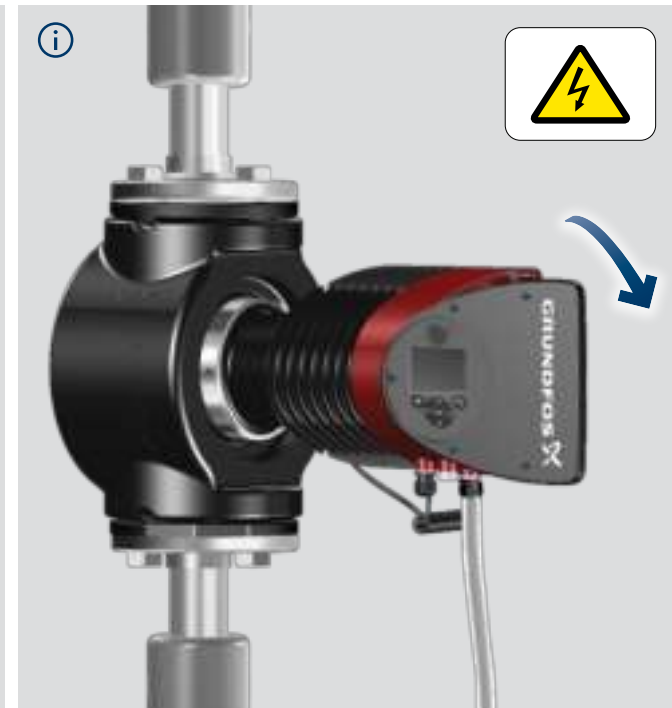
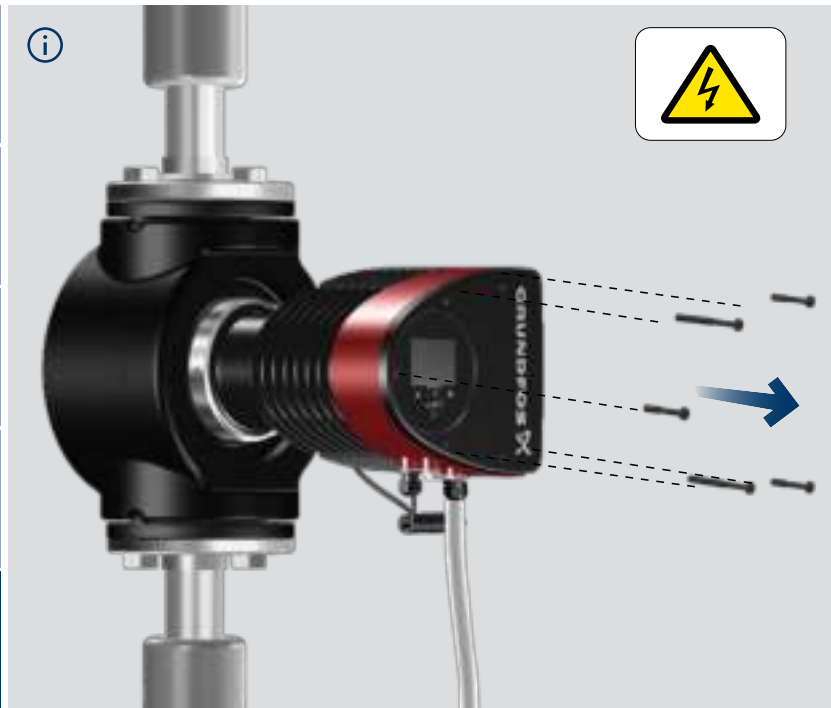

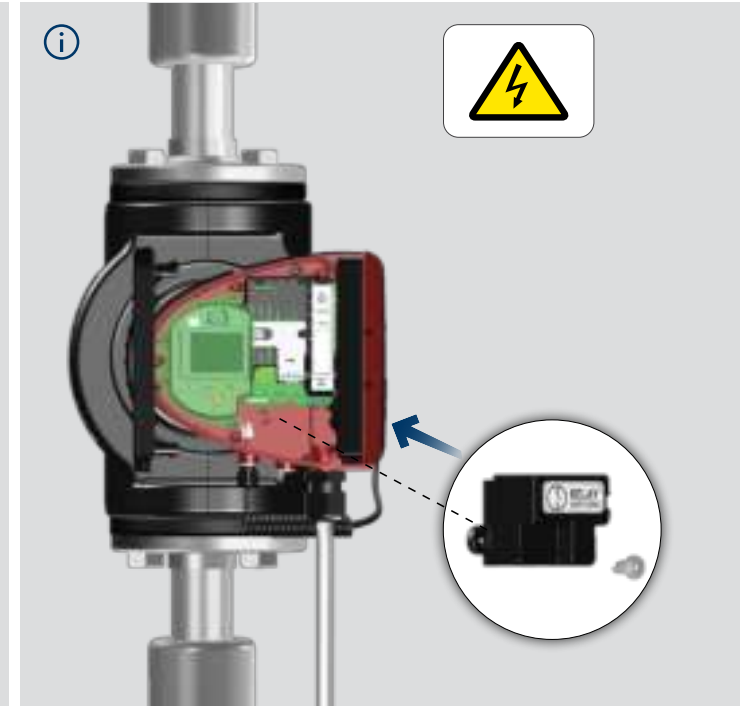
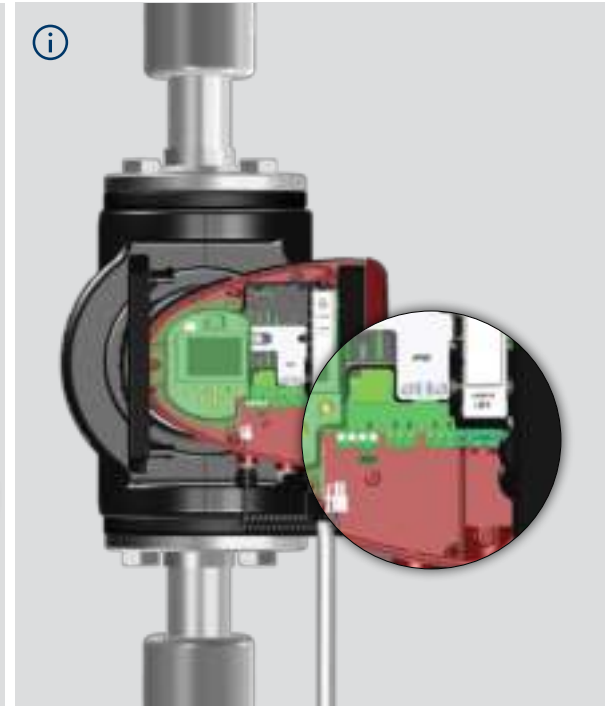
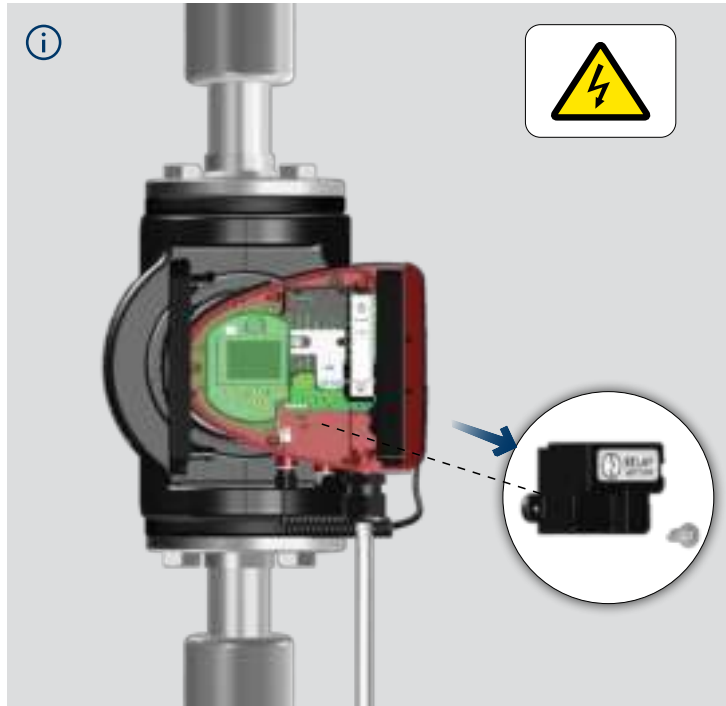

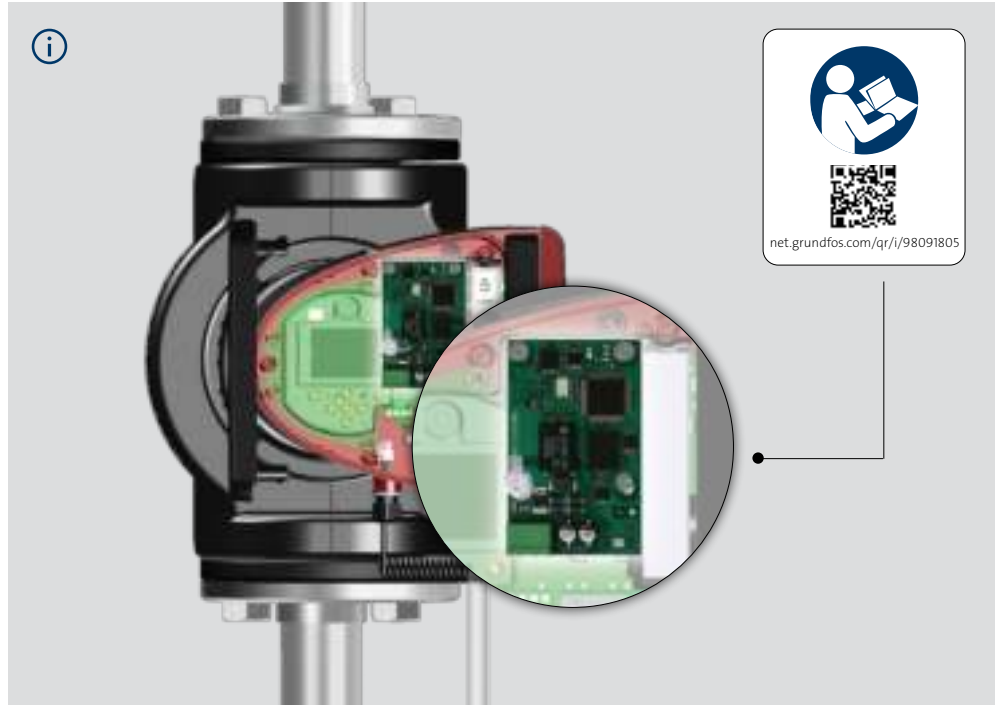

Installation date: _____

Installer:

98091803 08.2020

ECM: 1290594

GRUNDFOS Holding A/S
Poul Due Jensens Vej 7
DK-8850 Bjerringbro
Tel: +45 87 50 14 00
www.grundfos.com

GRUNDFOS 