

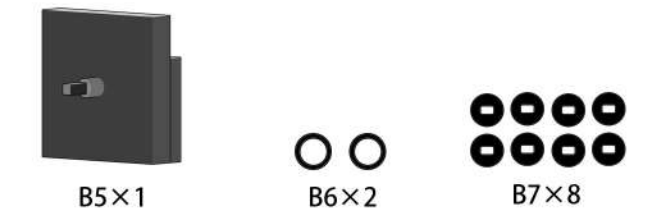

3D PUZZLE

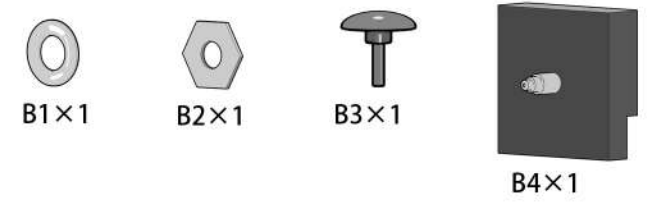
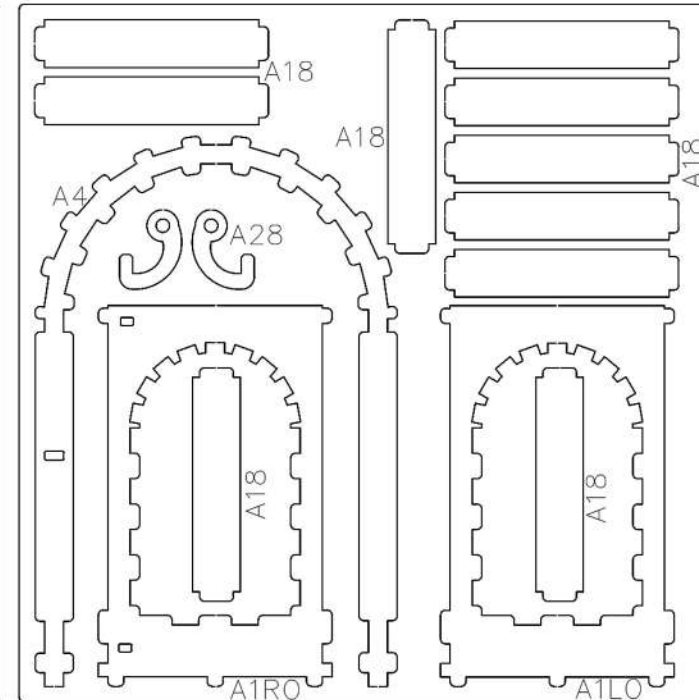
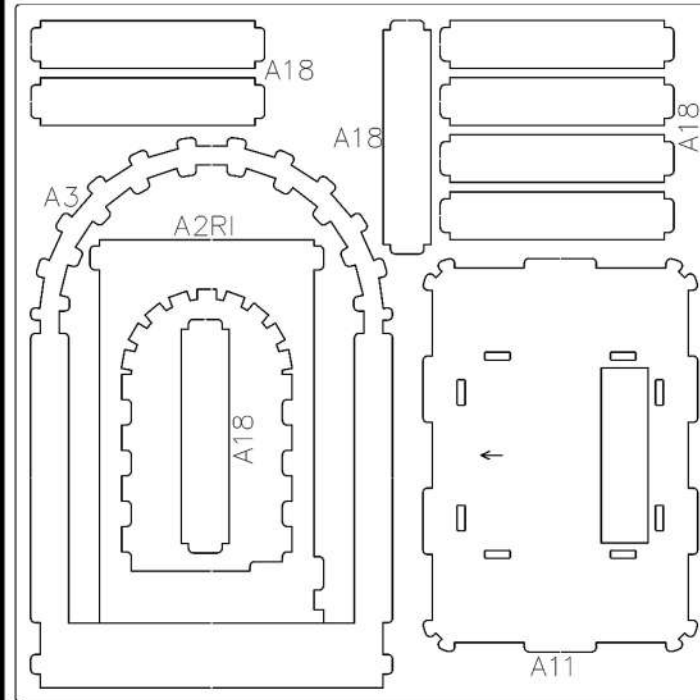
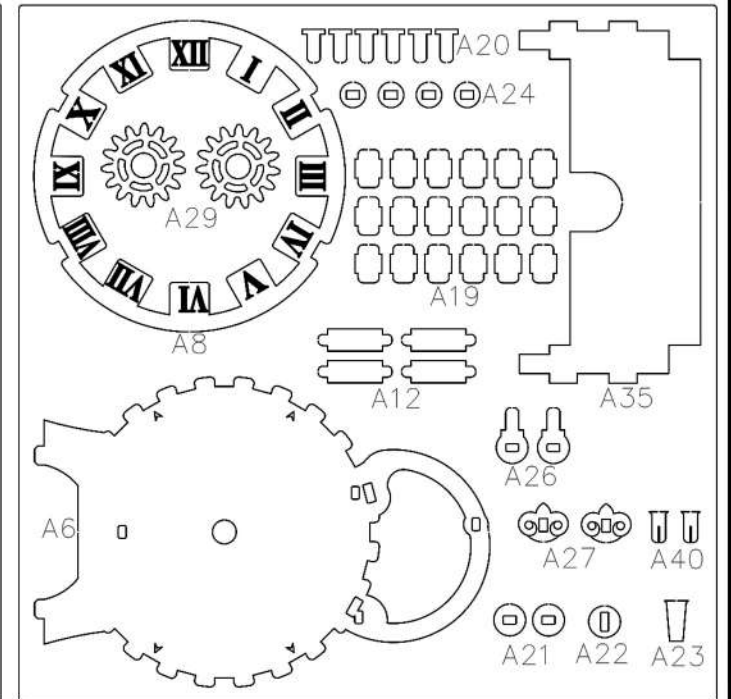
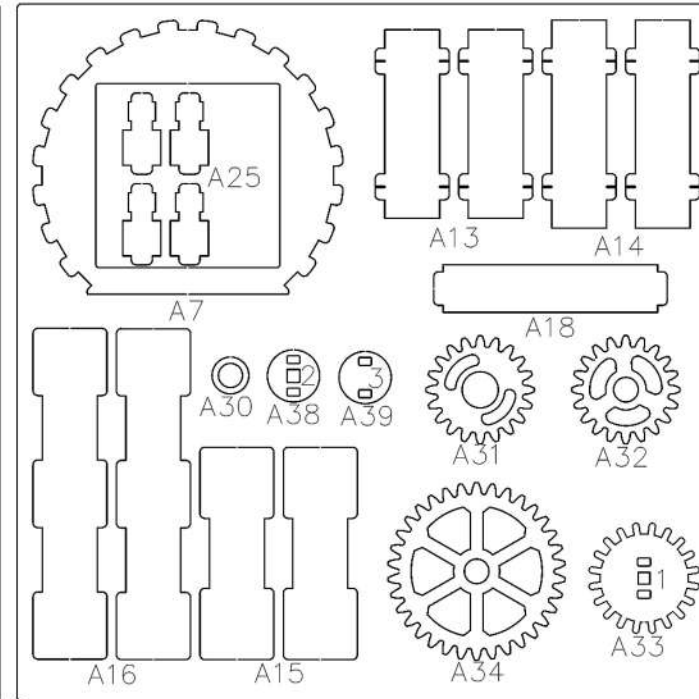
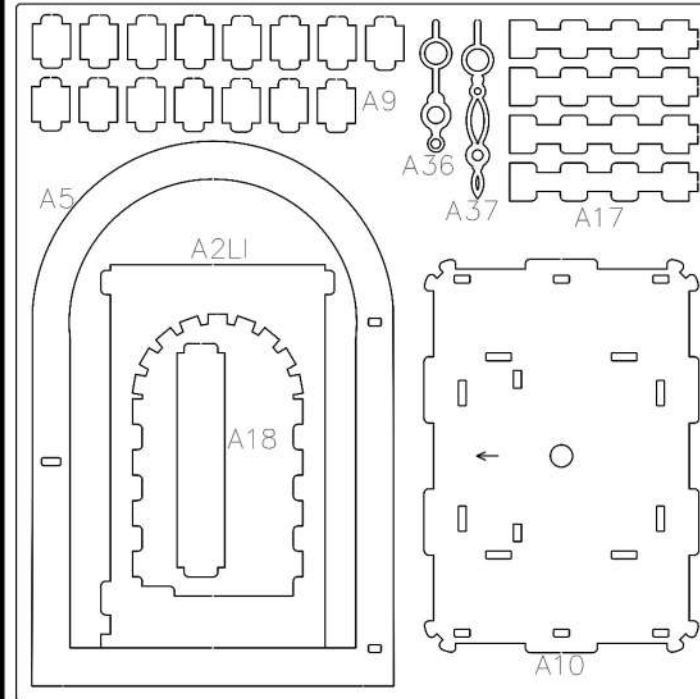
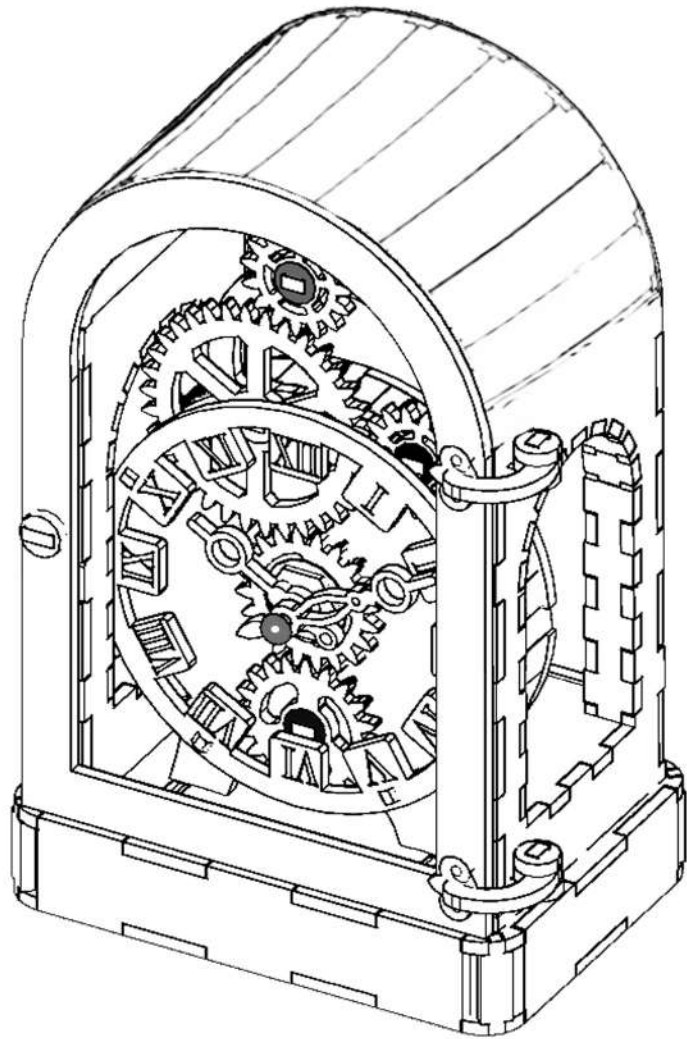

The hole in the center of the gear and the teeth of the gear need to be properly sanded with sandpaper.

1.

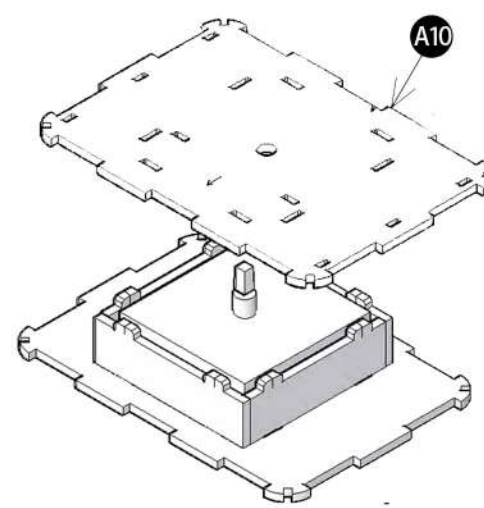
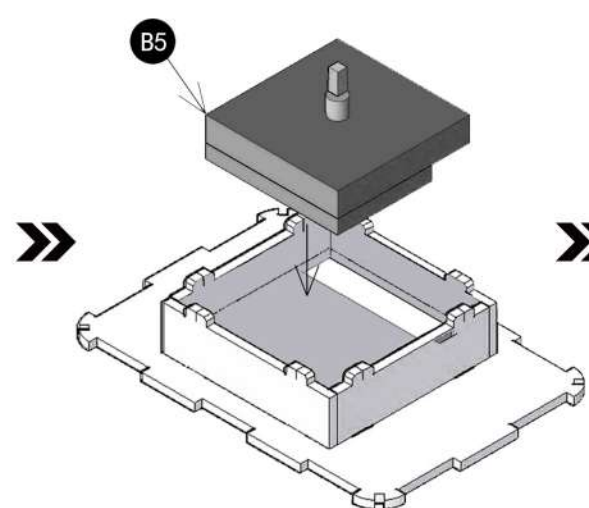
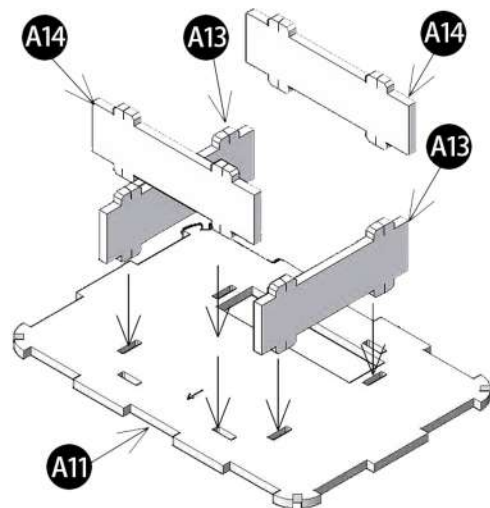

As shown in the figure, press the parts in sequence and install them.

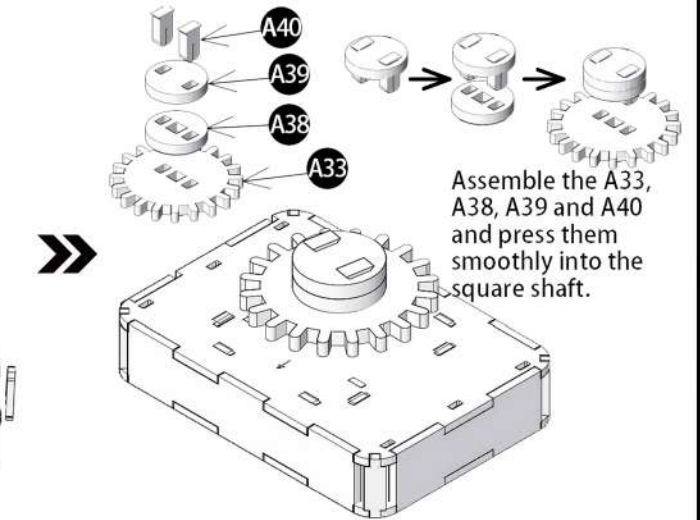
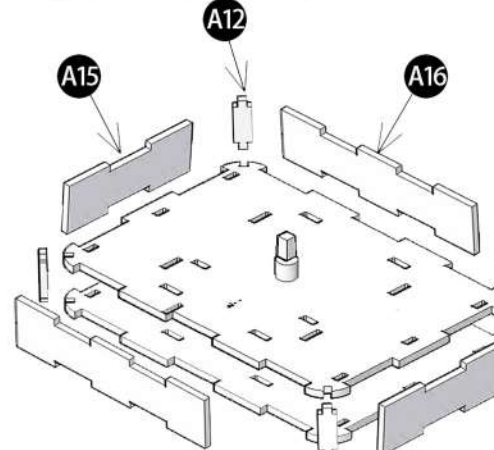

Assemble the A33, A38, A39 and A40 and press them smoothly into the square shaft.

