

POWERED STUDIO MONITOR

**HS8 / HS7 / HS5**  
**HS8I / HS7I / HS5I**

POWERED SUBWOOFER

**HS8S**

Owner's Manual  
Bedienungsanleitung  
Mode d'emploi  
Manual de instrucciones  
Manual do Proprietário  
Manuale di istruzioni  
Руководство пользователя  
取扱説明書

POWERED SPEAKER SYSTEM

English

Deutsch

Français

Español

Português

Italiano

Русский

日本語

EN

DE

FR

ES

PT

IT

RU

JA

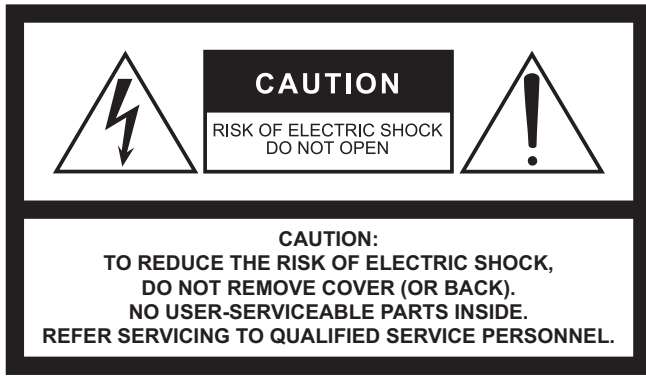

The above warning is located on the rear of the unit.



L'avertissement ci-dessus est situé sur l'arrière de l'unité.

## Explanation of Graphical Symbols Explication des symboles



The lightning flash with arrowhead symbol within an equilateral triangle is intended to alert the user to the presence of uninsulated "dangerous voltage" within the product's enclosure that may be of sufficient magnitude to constitute a risk of electric shock to persons.  
L'éclair avec une flèche à l'intérieur d'un triangle équilatéral est destiné à attirer l'attention de l'utilisateur sur la présence d'une « tension dangereuse » non isolée à l'intérieur de l'appareil, pouvant être suffisamment élevée pour constituer un risque d'électrocution.



The exclamation point within an equilateral triangle is intended to alert the user to the presence of important operating and maintenance (servicing) instructions in the literature accompanying the product.

Le point d'exclamation à l'intérieur d'un triangle équilatéral est destiné à attirer l'attention de l'utilisateur sur la présence d'instructions importantes sur l'emploi ou la maintenance (réparation) de l'appareil dans la documentation fournie.

## IMPORTANT SAFETY INSTRUCTIONS

- 1 Read these instructions.
- 2 Keep these instructions.
- 3 Heed all warnings.
- 4 Follow all instructions.
- 5 Do not use this apparatus near water.
- 6 Clean only with dry cloth.
- 7 Do not block any ventilation openings. Install in accordance with the manufacturer's instructions.
- 8 Do not install near any heat sources such as radiators, heat registers, stoves, or other apparatus (including amplifiers) that produce heat.
- 9 Do not defeat the safety purpose of the polarized or grounding-type plug. A polarized plug has two blades with one wider than the other. A grounding type plug has two blades and a third grounding prong. The wide blade or the third prong are provided for your safety. If the provided plug does not fit into your outlet, consult an electrician for replacement of the obsolete outlet.
- 10 Protect the power cord from being walked on or pinched particularly at plugs, convenience receptacles, and the point where they exit from the apparatus.
- 11 Only use attachments/accessories specified by the manufacturer.
- 12 Use only with the cart, stand, tripod, bracket, or table specified by the manufacturer, or sold with the apparatus. When a cart is used, use caution when moving the cart/apparatus combination to avoid injury from tip-over.
- 13 Unplug this apparatus during lightning storms or when unused for long periods of time.
- 14 Refer all servicing to qualified service personnel. Servicing is required when the apparatus has been damaged in any way, such as power-supply cord or plug is damaged, liquid has been spilled or objects have fallen into the apparatus, the apparatus has been exposed to rain or moisture, does not operate normally, or has been dropped.



### WARNING

TO REDUCE THE RISK OF FIRE OR ELECTRIC SHOCK, DO NOT EXPOSE THIS APPARATUS TO RAIN OR MOISTURE.

(UL60065\_03)

## PRÉCAUTIONS CONCERNANT LA SÉCURITÉ

- 1 Lire ces instructions.
- 2 Conserver ces instructions.
- 3 Tenir compte de tous les avertissements.
- 4 Suivre toutes les instructions.
- 5 Ne pas utiliser ce produit à proximité d'eau.
- 6 Nettoyer uniquement avec un chiffon propre et sec.
- 7 Ne pas bloquer les orifices de ventilation. Installer l'appareil conformément aux instructions du fabricant.
- 8 Ne pas installer l'appareil à proximité d'une source de chaleur comme un radiateur, une bouche de chaleur, un poêle ou tout autre appareil (y compris un amplificateur) produisant de la chaleur.
- 9 Ne pas modifier le système de sécurité de la fiche polarisée ou de la fiche de terre. Une fiche polarisée dispose de deux broches dont une est plus large que l'autre. Une fiche de terre dispose de deux broches et d'une troisième pour le raccordement à la terre. Cette broche plus large ou cette troisième broche est destinée à assurer la sécurité de l'utilisateur. Si la fiche équipant l'appareil n'est pas compatible avec les prises de courant disponibles, faire remplacer les prises par un électricien.
- 10 Acheminer les cordons d'alimentation de sorte qu'ils ne soient pas piétinés ni coincés, en faisant tout spécialement attention aux fiches, prises de courant et au point de sortie de l'appareil.
- 11 Utiliser exclusivement les fixations et accessoires spécifiés par le fabricant.
- 12 Utiliser exclusivement le chariot, le stand, le trépied, le support ou la table recommandés par le fabricant ou vendus avec cet appareil. Si l'appareil est posé sur un chariot, déplacer le chariot avec précaution pour éviter tout risque de chute et de blessure.
- 13 Débrancher l'appareil en cas d'orage ou lorsqu'il doit rester hors service pendant une période prolongée.
- 14 Confier toute réparation à un personnel qualifié. Faire réparer l'appareil s'il a subi tout dommage, par exemple si la fiche ou le cordon d'alimentation est endommagé, si du liquide a coulé ou des objets sont tombés à l'intérieur de l'appareil, si l'appareil a été exposé à la pluie ou à de l'humidité, si l'appareil ne fonctionne pas normalement ou est tombé.



### AVERTISSEMENT

POUR RÉDUIRE LES RISQUES D'INCENDIE OU DE DÉCHARGE ÉLECTRIQUE, N'EXPOSEZ PAS CET APPAREIL À LA PLUIE OU À L'HUMIDITÉ.

(UL60065\_03)

# Contents

<b>Features</b> .....	<b>3</b>
<b>Included Items (please check)</b> .....	<b>3</b>
<b>PRECAUTIONS</b> .....	<b>4</b>
<b>NOTICE</b> .....	<b>5</b>
<b>Rear Panel</b> .....	<b>6</b>
<b>Setup</b> .....	<b>8</b>
<b>Troubleshooting</b> .....	<b>12</b>
<b>Specifications</b> .....	<b>89</b>
<b>Dimensions</b> .....	<b>89</b>
<b>Performance Graph</b> .....	<b>90</b>
<b>Block Diagram</b> .....	<b>90</b>
<b>Tilt Angle (HS8I/HS7I/HS5I only)</b> .....	<b>91</b>

Thank you for choosing a Yamaha powered monitor speaker or powered subwoofer. In order to take maximum advantage of the speaker's features and ensure maximum performance and longevity, please read this manual carefully before using powered monitor speaker or powered subwoofer. Keep the manual in a safe place for future reference.

- The illustrations as shown in this manual are for instructional purposes only.
- The company names and product names in this manual are the trademarks or registered trademarks of their respective companies.
- In this manual (unless indicated otherwise), "HS8" refers to both the HS8 and HS8I, "HS7" refers to the HS7 and HS7I and "HS5" refers to the HS5 and HS5I.

# Features

- Accurate, detailed reproduction of the source.
- A choice of three full-range models plus one high-performance subwoofer makes it easy to create systems that are ideally matched to any monitoring environment.
- Simple 2-way design in the full-range models, with optimally matched high and low frequency units.
- Response-tailoring controls match speaker output to a wide range of acoustic spaces.
- In addition to studio standard XLR connectors, phone jacks allow direct connection of electronic musical instruments and other sources.

# Included Items (please check)

- **Power cord**
- **Screws for bracket installation (2; HS8I/HS7I/HS5I only)**
- **Owner's Manual (this book)**

# Optional Items

## For HS8I/HS7I/HS5I

You can use third-party bracket sold separately. For information on available third-party bracket, please refer to the Yamaha Pro Audio website. <https://www.yamahaproaudio.com/>

# PRECAUTIONS

## PLEASE READ CAREFULLY BEFORE PROCEEDING

Please keep this manual in a safe place for future reference.

This product is designed for accurate sound monitoring during audio recording, editing, mixing and other applications. Do not use for any purpose other than as a speaker. Those who are unfamiliar with handling or those who can not handle according to this manual, should be supervised by responsible persons to ensure safety.

### **WARNING**

**Always follow the basic precautions listed below to avoid the possibility of serious injury or even death from electrical shock, short-circuiting, damages, fire or other hazards. These precautions include, but are not limited to, the following:**

#### If you notice any abnormality

- If any of the following problems occur, immediately turn off the power switch and disconnect the electric plug from the outlet.
    - The power cord or plug becomes frayed or damaged.
    - Unusual smells or smoke are emitted.
    - Some object, or water has been dropped into the product.
    - There is a sudden loss of sound during use of the product.
    - Cracks or other visible damage appear on the product.
- Then have the product inspected or repaired by qualified Yamaha service personnel.

#### Power supply/Power cord

- Do not place the power cord near heat sources such as heaters or radiators, and do not excessively bend or otherwise damage the cord, place heavy objects on it, or place it in a position where anyone could walk on, trip over, or roll anything over it.
- Only use the voltage specified as correct for the product. The required voltage is printed on the name plate of the product.
- Use only the supplied power cord/plug.
 

If you intend to use the product in an area other than in the one you purchased, the included power cord may not be compatible. Please check with your Yamaha dealer.
- Check the electric plug periodically and remove any dirt or dust which may have accumulated on it.
- Make sure to fully insert the electric plug to prevent electric shocks or fire.
- When setting up the product, make sure that the AC outlet you are using is easily accessible. If some trouble or malfunction occurs, immediately turn off the power switch and disconnect the plug from the outlet. Even when the power switch is turned off, as long as the power cord is not unplugged from the wall AC outlet, the product will not be disconnected from the power source.
- Remove the electric plug from the outlet when the product is not to be used for extended periods of time.
- Do not touch the product or the electric plug during an electrical storm.
- Be sure to connect to an appropriate outlet with a protective grounding connection. Improper grounding can result in electrical shock, fire, or damage.

#### Do not open

- This product contains no user-serviceable parts. Do not attempt to disassemble the internal parts or modify them in any way.

#### Water warning/Fire warning

- Do not expose the product to rain, use it near water or in damp or wet conditions, or place on it any containers (such as vases, bottles or glasses) containing liquids which might spill into any openings.
- Never insert or remove an electric plug with wet hands.
- Do not place any burning items or open flames near the product, since they may cause a fire.

#### Hearing loss

- Before turning the power of all devices on or off, make sure that all volume levels are set to the minimum. Failing to do so may result in hearing loss or device damage.
- When turning on the AC power in your audio system, always turn on the product LAST, to avoid hearing loss and speaker damage. When turning the power off, the product should be turned off FIRST for the same reason.



### **CAUTION**

**Always follow the basic precautions listed below to avoid the possibility of physical injury to you or others. These precautions include, but are not limited to, the following:**

#### Power supply/Power cord

- When removing the electric plug from the product or an outlet, always hold the plug itself and not the cord. Pulling by the cord can damage it.

#### Location and connection

- Do not place the product in an unstable position or a location with excessive vibration, where it might accidentally fall over and cause injury.
- Keep this product out of reach of children. This product is not suitable for use in locations where children are likely to be present.
- When installing the product:
  - Do not cover it with any cloth.
  - Do not install it on a carpet or rug.
  - Make sure the top surface faces up; do not install on its sides or upside down.
  - Do not use the product in a confined, poorly-ventilated location. Inadequate ventilation can result in overheating, possibly causing damage to the product(s), or even fire. Make sure that there is adequate space around the product: at least 20cm above, 20cm at the sides and 20cm behind.
- Do not place the product in a location where it may come into contact with corrosive gases or salt air. Doing so may result in malfunction.
- Before moving the product, remove all connected cables.
- Do not press the rear panel of the product against the wall. Doing so may cause the plug to come in contact with the wall and detach from the power cord, resulting in short circuiting, malfunction, or even fire.
- (HS8I/HS7I/HS5I only)
 

Always consult qualified Yamaha service personnel and make sure to observe the following precautions if the product installation requires construction work.

  - Choose mounting hardware and an installation location that can support the weight of the product.
  - Avoid locations that are exposed to constant vibration.
  - Use the required tools to install the device.
  - Inspect the device periodically.

Improper installation might cause accidents, injuries, damage or malfunction of this product.

#### Maintenance

- Remove the power plug from the AC outlet when cleaning the product.

#### Handling caution

- Do not insert your fingers or hands in any gaps or openings on the product (ports).
- Do not rest your weight on the product or place heavy objects on it.
- Do not operate the product if the sound is distorting. Prolonged use in this condition could cause overheating and result in fire.

#### About disposal

This product contains recyclable components. When disposing of this product, please contact the appropriate local authorities.

Yamaha cannot be held responsible for damage caused by improper use or modifications to the device.

# NOTICE

To avoid the possibility of malfunction/damage to the product, damage to data, or damage to other property, follow the notices below.

## ■ Handling and maintenance

- Do not use the product in the vicinity of a TV, radio, or other electric products. Otherwise, the product, TV, or radio may generate noise.
- Do not expose the product to excessive dust or vibration, or extreme cold or heat, in order to prevent the possibility of panel disfiguration, unstable operation, or damage to the internal components.
- Do not install in locations where temperature changes are severe. Otherwise, condensation may form on the inside or the surface of the product, causing it to break or deform the wood. Do not leave condensation on the wood; wipe immediately with a soft cloth.
- If there is reason to believe that condensation might have occurred, leave the product for several hours without turning on the power until the condensation has completely dried out, in order to prevent possible damage.
- Do not touch the speaker driver unit, since it might cause malfunction.
- Do not place vinyl, plastic or rubber objects on the product, since this might cause alteration or discoloration of the panel.
- When cleaning the product, use a dry and soft cloth. Do not use paint thinners, solvents, cleaning fluids, or chemical-impregnated wiping cloths, since this might cause alteration or discoloration.
- Do not place the speaker face down.
- These speakers should be used vertically, not laid on their side.
- Air blowing out of the bass reflex ports is normal, and often occurs when the speaker is handling program material with heavy bass content.
- Always turn the power off when the device is not in use.

## ■ Connectors

- XLR-type connectors are wired as follows (IEC60268 standard): pin 1: ground, pin 2: hot (+), and pin 3: cold (-).

## Connectable cables

### ■ XLR type

XLR type connectors are widely used in professional audio equipment and installations. The XLR type connectors provided on the HS series speakers are primarily intended for use with balanced connections.

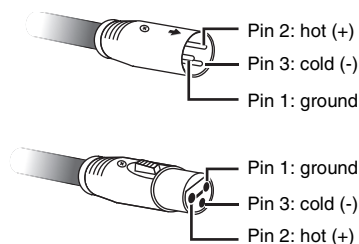

### ■ Phone type

Phone type connectors can be used for both unbalanced and balanced connections.

Cables fitted with TRS (tip, ring, sleeve) phone plugs are necessary for balanced connections to the HS series speakers. The construction of TRS phone plugs is basically the same as stereo phone plugs.

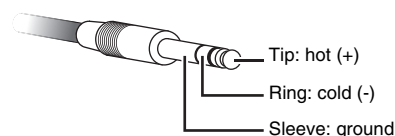

For unbalanced connections, connect standard mono phone plug cables to the HS speaker phone connectors.

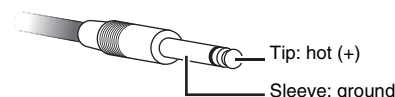

### ■ RCA pin

Source devices that only have RCA pin type output connectors can be connected via RCA pin plug to phone plug conversion cables (cables with an RCA pin plug on one end and a phone plug on the other). Connections using RCA pin plug to phone plug conversion cables are unbalanced.

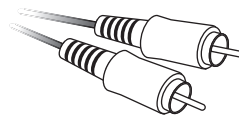

**Balanced connections:** These effectively cancel noise picked up from external sources. Balanced connections allow for longer cable runs that would probably otherwise result in more noise being picked up.

**Unbalanced connections:** Commonly used to connect electronic musical instruments and guitars, etc., to amplification equipment. If your cable runs do not extend past one or two meters, unbalanced cables can probably be used without any problems.

# Rear Panel

The HS8/HS7/HS5/HS8S switches and connectors are located on the rear panel, as described below.

## HS8/HS7/HS5

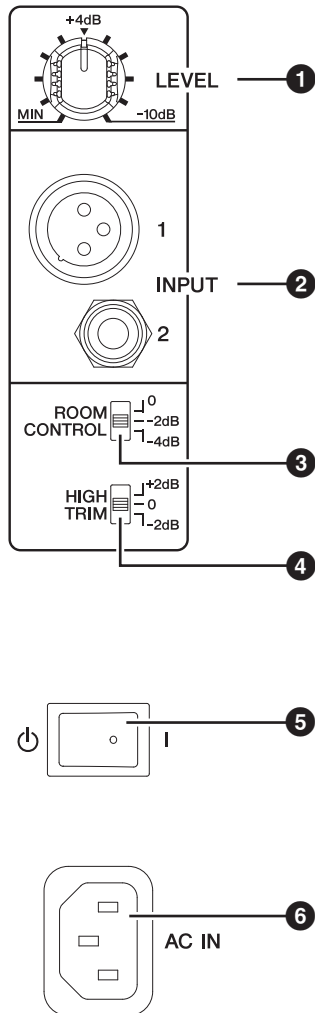

## Speaker Input and Response Control

### 1 LEVEL control

Adjusts the output level of the speaker. When set to the 12-o'clock position the speaker is optimized for a nominal input level of +4 dB.

### 2 INPUT 1/2 connector

These connectors receive the input signal to the speaker. Two input connectors are provided: one balanced XLR connector, and one balanced (TRS) phone jack.

**NOTE** The XLR and phone jack input connectors can not be used simultaneously. Use only one input connector at a time.

**NOTE** Refer to "Connectable cables" on page 5 for more connector details.

### 3 ROOM CONTROL switch

Adjusts the speaker's low-frequency response. This switch can be used to compensate for exaggerated low-frequency response that can be caused by reflections in some listening environments. Setting the switch to the [0] position produces a flat frequency response. The [-2 dB] setting attenuates the range below 500 Hz by 2 dB, and the [-4 dB] setting attenuates the range below 500 Hz by -4 dB.

### 4 HIGH TRIM switch

Adjusts the speaker's high-frequency response. Setting the switch to the [0] position produces a flat frequency response. The [+2 dB] setting boosts the range above 2 kHz by 2 dB, while the [-2 dB] setting attenuates the range above 2 kHz by -2 dB.

### 5 Power switch

Turns power to the speaker ON or OFF. Rock the switch to the right [ I ] to turn the power ON, or to the left [ ⏻ ] to turn the power OFF. The logo on the front panel will light when the power is ON.

#### NOTICE

- Turning the power switch ON and OFF in rapid succession can cause the device's electronics to malfunction. Please wait for 3 seconds or more after turning the power OFF before turning it ON again.
- Even when the power switch is turned off, electricity is still flowing to the product at the minimum level. When you are not using the product for a long time, make sure to unplug the power cord from the wall AC outlet.

### 6 AC IN connector

Connect the supplied power cable here. First connect the power cord to the speaker, then insert the power cord plug into the AC outlet.

# HS8S (Subwoofer)

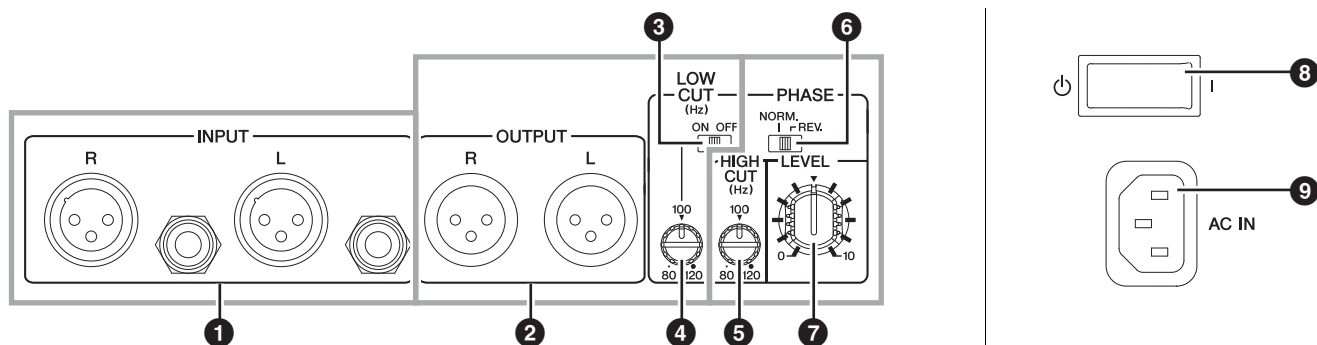

## Subwoofer Connections

### 1 INPUT L/R connector

These connectors receive the input signal to the subwoofer. Balanced XLR and balanced phone jack connectors are provided for both the L and R inputs. The L and R inputs can be used simultaneously. Signals supplied to both the L and R inputs are mixed internally.

**NOTE** The XLR and phone jack input connectors can not be used simultaneously. Use only one input connector at a time.

**NOTE** Refer to “Connectable cables” on page 5 for more connector details.

## HS8S signal flow

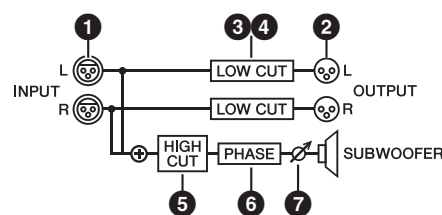

## Connecting the Subwoofer to the HS8/HS7/HS5 Speakers

### 2 OUTPUT L/R connectors

These are the subwoofer’s output connectors. The input signals received at the INPUT L and R connectors are output via the OUTPUT L and R connectors, respectively. Low frequency reproduction characteristics can be adjusted via the LOW CUT switch and LOW CUT control.

### 3 LOW CUT switch

When this switch is ON, the low frequencies are attenuated prior to output via the OUTPUT L and R connectors at the frequency set by the LOW CUT control. The low-frequency attenuation cutoff frequency can be adjusted via the LOW CUT control.

### 4 LOW CUT control

Adjusts the low-frequency attenuation cutoff frequency between 80 Hz and 120 Hz when the LOW CUT switch is ON.

## Subwoofer Response Control

### 5 HIGH CUT control

Sets the cutoff frequency for subwoofer output high-frequency attenuation from 80 Hz to 120 Hz.

### 6 PHASE switch

Switches the phase of the subwoofer output. This switch should be set to [NORM.] in most situations, but in combination with some speakers and in some speaker layouts switching to the [REV.] setting may improve low-frequency response. Select the setting that provides the best bass response in your system.

### 7 LEVEL control

Adjusts the subwoofer output level.

### 8 Power switch

Turns power to the subwoofer ON or OFF. Rock the switch to the right [ I ] to turn the power ON, or to the left [ ⏻ ] to turn the power OFF. The logo on the front panel will light when the power is ON.

#### NOTICE

- Turning the power switch ON and OFF in rapid succession can cause the device’s electronics to malfunction. Please wait for 3 seconds or more after turning the power OFF before turning it ON again.
- Even when the power switch is turned off, electricity is still flowing to the product at the minimum level. When you are not using the product for a long time, make sure to unplug the power cord from the wall AC outlet.

### 9 AC IN connector

Connect the supplied power cable here. First connect the power cord to the subwoofer, then insert the power cord plug into the AC outlet.

# Setup

In this section we'll look at the general procedure for connecting and setting up a monitor speaker system. This is just an example though, so feel free to set up your own system in the way that best serves your personal listening needs.

## Cables

You'll need to acquire appropriate cables to connect the HS series monitor speakers to your audio interface or other source equipment.

- **Short, high-quality cables**

Use high-quality cables of the shortest practical length. The longer the cable, the more chance there is that noise will creep in to degrade your sound.

- **Balanced cables**

Balanced cables are more resistant to noise than unbalanced cables. If you have to use unbalanced cables because the source equipment only has unbalanced outputs, be sure to use the shortest possible unbalanced cables.

### ■ Recommended cables

- For connection to a balanced phone jack input.

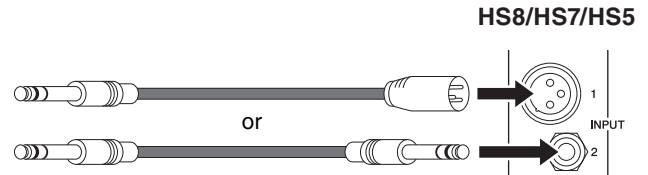

- For connection to an unbalanced phone jack input.

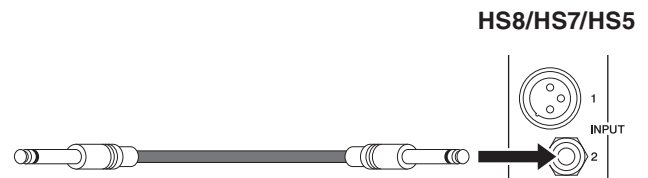

**NOTE** Refer to "Connectable cables" on page 5 for more connector details. The configurations of the balanced and unbalanced phone jack connectors are different.

## Connections

### NOTICE

Plug the supplied AC power cord into the corresponding socket on the speaker. Plug the power cord into the speaker first, and then insert the AC plug end into an appropriate AC wall outlet.

### Connecting to an Audio Interface

When connecting an audio interface (Steinberg UR or AXR series, etc.) to HS series speakers, connect the audio interface output connectors directly to the speakers' input connectors. Normally you'll connect to the LINE OUT 1 and 2 (1L and 2R outputs), although that might depend on the specific audio interface and DAW (Digital Audio Workstation) settings used.

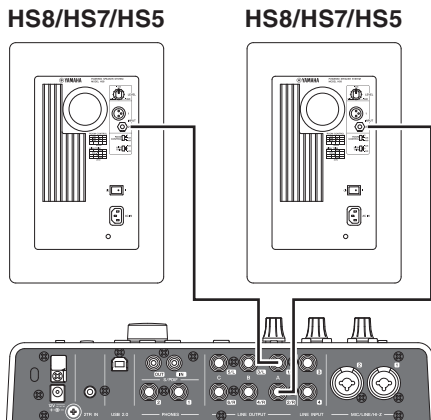

### Connecting to a Mixer

When connecting a mixer (Yamaha MGP or MG series, etc.) to HS series speakers, connect the mixer's MONITOR OUT or C-R OUT (Control Room) connectors directly to the speakers' input connectors. This makes it possible to control the monitor level independently from the mixer's main bus level.

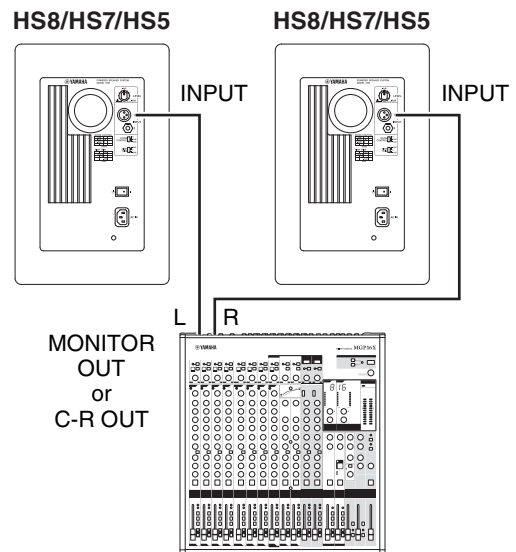

## ■ Recommended cables

- For connection to a balanced XLR input.

HS8/HS7/HS5

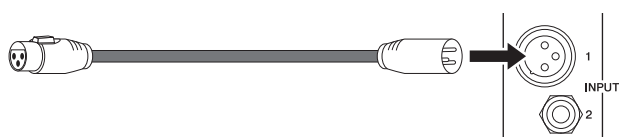

- For connection to an unbalanced phone jack input.

HS8/HS7/HS5

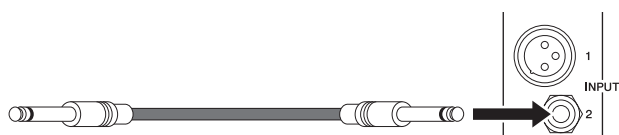

**NOTE** Refer to “Connectable cables” on page 5 for more connector details. The configurations of the balanced and unbalanced phone jack connectors are different.

## Connecting to a Synthesizer or Other Electronic Musical Instrument

When connecting an electronic musical instrument such as a Yamaha MONTAGE synthesizer to the HS series speakers, connect the instrument’s L/MONO and R outputs to the HS speaker inputs.

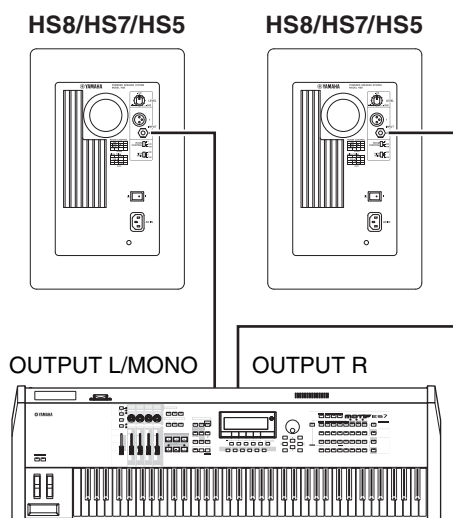

## ■ Recommended cables

- For connection to an unbalanced phone jack input.

HS8/HS7/HS5

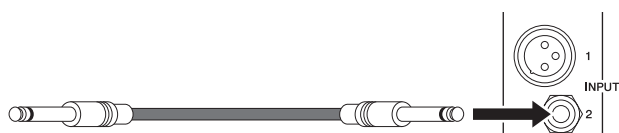

**NOTE** Refer to “Connectable cables” on page 5 for more connector details. The configurations of the balanced and unbalanced phone jack connectors are different.

## Setting Up for Superior Sound

A number of points should be observed when laying out a monitor speaker system.

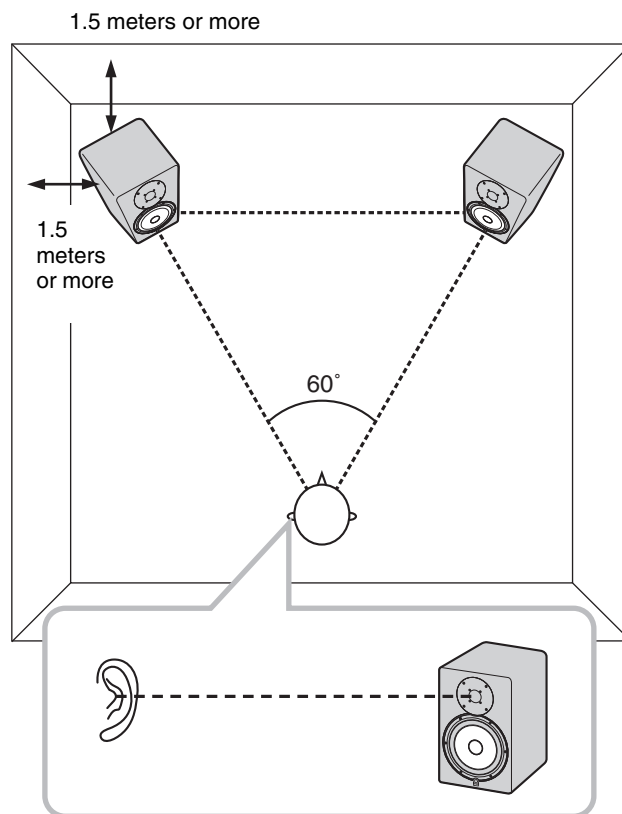

### ■ Point 1

**Position speakers at least 1.5 meters away from walls or corners.**

Ideally, the speakers should be located at least 1.5 meters away from walls or corners. In situations where it is not possible to position the speakers a sufficient distance from walls or corners, the ROOM CONTROL switch can be used to compensate for excessive bass. As you move the speaker closer to walls or corners, a higher compensation setting may be required to achieve natural sounding response ([0] → [-2] → [-4]).

## ■ Point 2

### Position the left and right speakers symmetrically.

The left and right speakers should be positioned as symmetrically as possible in relation to the room. In other words, the left and right speakers should be the same distance from the rear wall and the respective left and right walls.

## ■ Point 3

### The optimum listening position is at the apex of an equilateral triangle.

For the most accurate sound and balance, position yourself at the apex of an equilateral triangle formed by the left and right speakers and yourself, with the speakers angled inward so that they're facing you.

## ■ Point 4

### Position the tweeters at ear height.

High frequencies are quite directional, so for the most accurate monitoring the speakers should be set up so that the tweeters are at approximately the same height as your ears when you're seated at the listening position.

## HS8/HS7/HS5 Settings

Once the physical layout of your monitor system is finalized, you can begin making the following settings.

- 1 Turn the level/volume controls on all source equipment (audio interface, etc.) all the way down.**
- 2 Set the HS8/HS7/HS5 LEVEL control to the 12-o'clock position, and set both ROOM CONTROL and HIGH TRIM switches to 0 dB.**
- 3 Turn the power to connected audio source devices on first, and then turn on power to the speakers.**

#### NOTICE

When turning power off, turn off the speakers first, and then turn off connected audio source devices.

- 4 Play some source material and gradually raise the level/volume controls on the source equipment.**

#### NOTICE

Be careful not to suddenly apply an excessively loud signal to the system. Excessive level can damage the speakers.

- 5 Set the listening level to a level at which you can listen comfortably without fatigue for an extended period of time.**

**NOTE** If necessary, adjust the ROOM CONTROL and HIGH TRIM switches for the most natural response (refer to page 6).

## Adding a Subwoofer (HS8S)

Adding a subwoofer to your monitor system can significantly improve its low-frequency fidelity, making it possible to create better overall mixes.

The subwoofer is normally placed on the floor between the left and right full-range speakers, but since the subwoofer reproduces low frequencies below 200 Hz that are relatively non-directional, subwoofer positioning is not critical.

Four cables are required: two to connect the audio interface or other source equipment to the HS8S subwoofer, and two more to connect the subwoofer to the left and right HS8/HS7/HS5 main speakers.

The connections are made as shown below.

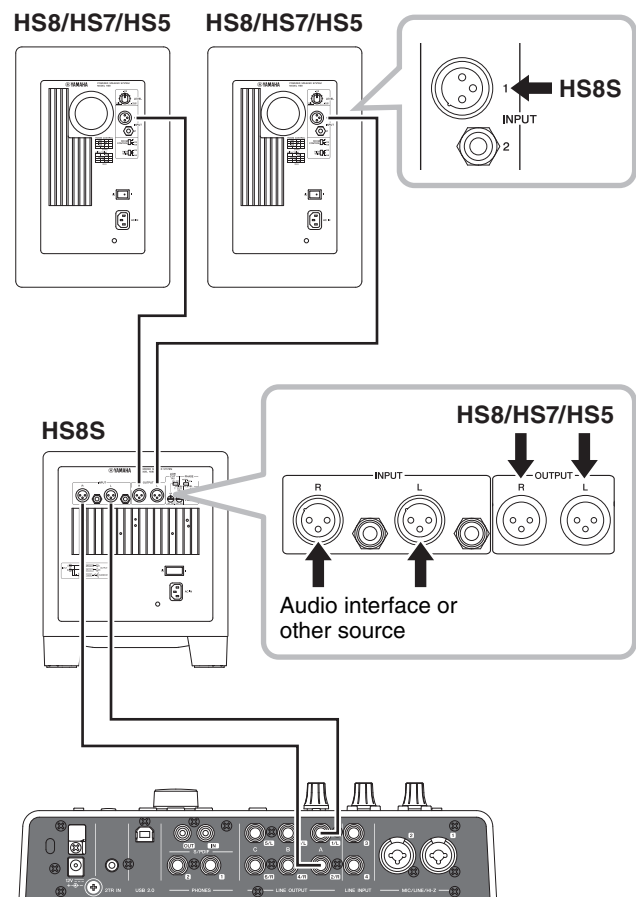

#### NOTICE

Plug the supplied AC power cord into the corresponding socket on the speaker. Plug the power cord into the speaker first, and then insert the AC plug end into an appropriate AC wall outlet.

## ■ Recommended cables

Cables for connecting the audio source (audio interface, etc.) to the HS8S

- For connection to a balanced phone jack input.

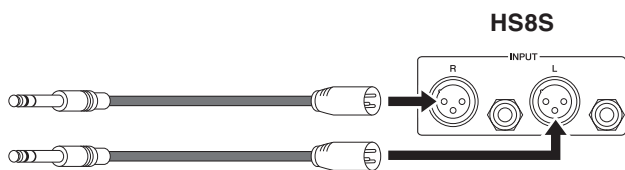

- For connection to a balanced XLR input.

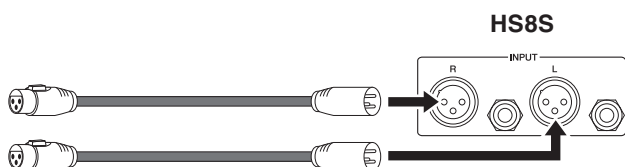

- For connection to an unbalanced phone jack input.

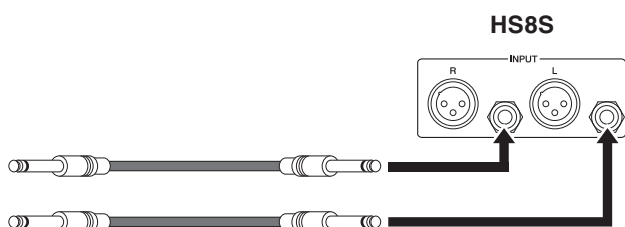

Cables for connection between the HS8S and HS8/HS7/HS5

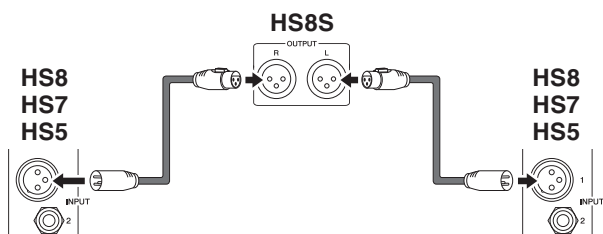

**NOTE** Refer to “Connectable cables” on page 5 for more connector details. The configurations of the balanced and unbalanced phone jack connectors are different.

## ■ Settings for Speakers Plus Subwoofer

Once the subwoofer connections have been made and the layout is finalized, you can begin making the following settings.

- 1 Turn the level/volume controls on all source equipment (audio interface, etc.) all the way down.
- 2 Set the HS8/HS7/HS5 LEVEL control to the 12-o'clock position, and set both ROOM CONTROL and HIGH TRIM switches to 0 dB.

- 3 Set the HS8S LEVEL control to 0, the HIGH CUT and LOW CUT controls to their 12-o'clock positions, and set the LOW CUT switch to OFF.

- 4 Turn power on in the following order: audio source devices, then subwoofer, and finally the full-range speakers.

### NOTICE

Turn power off in the following order: full-range speakers, then subwoofer, and finally audio source devices.

- 5 Play some source material and gradually raise the level/volume controls on the source equipment.

### NOTICE

Be careful not to suddenly apply an excessively loud signal to the system. Excessive level can damage the speakers.

- 6 Set the HS8S LEVEL control to between 10 and 12 o'clock, and turn the LOW CUT switch ON.

- 7 Set the listening level to a level at which you can listen comfortably without fatigue for an extended period of time.

**NOTE**

- If necessary, adjust the ROOM CONTROL and HIGH TRIM switches for the most natural response (refer to page 6).
- If necessary, adjust the LOW CUT and HIGH CUT controls and the PHASE switch for the most natural response (refer to page 7).

## Installing Brackets (HS8I/HS7I/HS5I only)

HS8I/HS7I/HS5I can be installed with optional brackets. Two screw holes for installing the brackets are located on each of the four surfaces (top, bottom, left and right).

Refer also to the bracket installation manual. Note that there are two sets of screws: those that are originally installed in the speaker cabinet (to plug the installation holes) and those (for bracket installation) that are included in the product package. When installing brackets to the speaker, remove the original screws and make sure to use only the screws included in the product package for bracket installation.

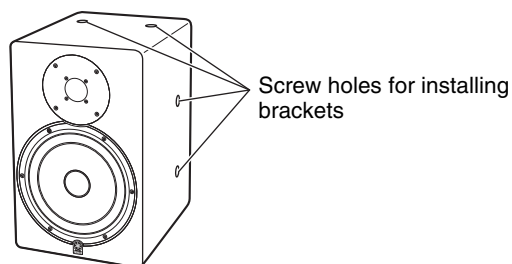

**Caution**

- Construction work should be carried out by a professional constructor.
- Do not install the speaker transversely.
- Make sure not to touch the cone when installing.
- For optimum safety, the installation should be checked thoroughly at regular intervals. Some fittings may deteriorate over extended periods of time due to wear and/or corrosion, or the mounted parts may loosen.
- When choosing the installation location such as wall and ceiling and mounting hardware (bolts, nuts), make sure all are strong enough to support the weight of the speaker.
- Make sure to properly use the safety wire to prevent the speaker from falling down in the event of an installation failure.
- When installing the safety wire to the ceiling or wall, install it higher than the wire's attachment point on the speaker to reduce slack. Also, ensure that the installation height and location would pose no danger to people should the speaker fall.
- Yamaha does not assume any responsibilities for accidents such as dropping due to insufficient strength at attachment points or inadequacy of the mounting method.
- The recommended tightening torque for installing the included screws for bracket installation is 6.2 Nm for the M8 screw (HS8I and HS7I) and 2.4 Nm for the M5 screw (HS5I).
- Use safety wires with the following specifications.

Diameter	Ø3.0 mm or more
Length	Less than 600 mm
Material	Stainless steel
Breaking load	6,370 N (650 kg) or more

**NOTE** Do not use the speaker if the screws at locations where brackets are not installed have been removed. This causes air leaks to occur from the enclosure, resulting in undesirable performance.

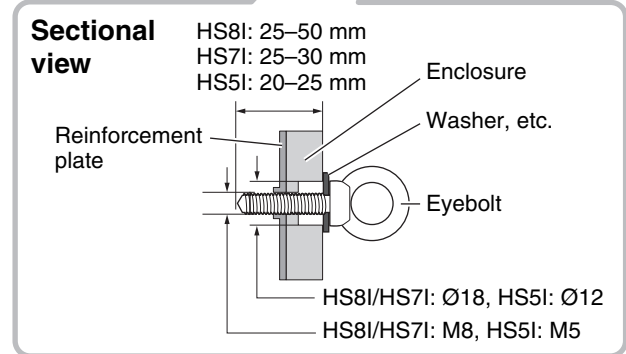
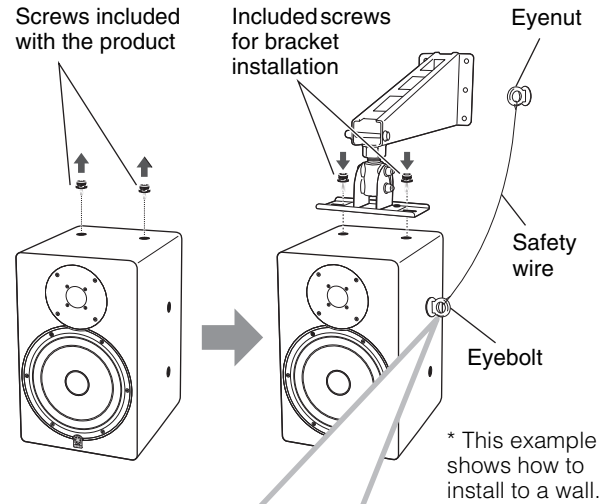

# Troubleshooting

Symptom	Possible Cause	Solution
Power won't turn on / front panel logo doesn't light.	The power cord might not be connected properly.	Check and connect the power cord.
	The power switch might not be turned on.	Turn the power switch ON. If the problem persists, contact your Yamaha dealer.
No sound.	One or more cables might not be connected properly.	Check that all cables are properly connected.
	The source equipment might not be supplying an audio signal.	Make sure that the source equipment is functioning properly and delivering the required signal.
	The level setting might be too low.	Adjust the output level setting of the source equipment, or use the LEVEL control to increase the output level.
	Are cables connected to both the XLR and phone jack INPUT connectors?	The XLR and phone jack input connectors can not be used simultaneously. Use only one input connector at a time.
Noisy or distorted sound.	One or more cables might be corroded, shorted, or otherwise broken.	Replace faulty cable(s).
	The system might be picking up external noise.	Try changing the positions or layout of the cables.
		Try changing the location of other electrical/ electronic devices that are near the speakers.

### Information for users on collection and disposal of old equipment:



This symbol on the products, packaging, and/or accompanying documents means that used electrical and electronic products should not be mixed with general household waste. For proper treatment, recovery and recycling of old products, please take them to applicable collection points, in accordance with your national legislation.

By disposing of these products correctly, you will help to save valuable resources and prevent any potential negative effects on human health and the environment which could otherwise arise from inappropriate waste handling.

For more information about collection and recycling of old products, please contact your local municipality, your waste disposal service or the point of sale where you purchased the items.

#### For business users in the European Union:

If you wish to discard electrical and electronic equipment, please contact your dealer or supplier for further information.

#### Information on Disposal in other Countries outside the European Union:

This symbol is only valid in the European Union. If you wish to discard these items, please contact your local authorities or dealer and ask for the correct method of disposal.

(weee\_eu\_en\_02)

### Información para usuarios sobre la recogida y eliminación de los equipos antiguos



Este símbolo en los productos, embalajes y documentos anexos significa que los productos eléctricos y electrónicos no deben mezclarse con los desperdicios domésticos normales. Para el tratamiento, recuperación y reciclaje apropiados de los productos antiguos, llévelos a puntos de reciclaje correspondientes, de acuerdo con la legislación nacional.

Al deshacerse de estos productos de forma correcta, ayudará a ahorrar recursos valiosos y a impedir los posibles efectos desfavorables en la salud humana y en el entorno que de otro modo se producirían si se trataran los desperdicios de modo inapropiado.

Para obtener más información acerca de la recogida y el reciclaje de los productos antiguos, póngase en contacto con las autoridades locales, con el servicio de eliminación de basuras o con el punto de venta donde adquirió los artículos.

#### Para los usuarios empresariales de la Unión Europea:

Si desea desechar equipos eléctricos y electrónicos, póngase en contacto con su vendedor o proveedor para obtener más información.

#### Información sobre la eliminación en otros países fuera de la Unión Europea:

Este símbolo solo es válido en la Unión Europea. Si desea desechar estos artículos, póngase en contacto con las autoridades locales o con el vendedor y pregúnteles el método correcto.

(weee\_eu\_es\_02)

### Verbraucherinformation zur Sammlung und Entsorgung alter Elektrogeräte



Befindet sich dieses Symbol auf den Produkten, der Verpackung und/oder beiliegenden Unterlagen, so sollten benutzte elektrische Geräte nicht mit dem normalen Haushaltsabfall entsorgt werden.

In Übereinstimmung mit Ihren nationalen Bestimmungen bringen Sie alte Geräte bitte zur fachgerechten Entsorgung, Wiederaufbereitung und Wiederverwendung zu den entsprechenden Sammelstellen.

Durch die fachgerechte Entsorgung der Elektrogeräte helfen Sie, wertvolle Ressourcen zu schützen, und verhindern mögliche negative Auswirkungen auf die menschliche Gesundheit und die Umwelt, die andernfalls durch unsachgerechte Müllentsorgung auftreten könnten.

Für weitere Informationen zum Sammeln und Wiederaufbereiten alter Elektrogeräte kontaktieren Sie bitte Ihre örtliche Stadt- oder Gemeindeverwaltung, Ihren Abfallentsorgungsdienst oder die Verkaufsstelle der Artikel.

#### Information für geschäftliche Anwender in der Europäischen Union:

Wenn Sie Elektrogeräte ausrangieren möchten, kontaktieren Sie bitte Ihren Händler oder Zulieferer für weitere Informationen.

#### Entsorgungsinformation für Länder außerhalb der Europäischen Union:

Dieses Symbol gilt nur innerhalb der Europäischen Union. Wenn Sie solche Artikel ausrangieren möchten, kontaktieren Sie bitte Ihre örtlichen Behörden oder Ihren Händler und fragen Sie nach der sachgerechten Entsorgungsmethode.

(weee\_eu\_de\_02)

### Informações para os utilizadores relativas à recolha e eliminação de equipamentos usados



Este símbolo, presente em produtos, embalagens e/ou incluído na documentação associada, indica que os produtos elétricos e eletrónicos usados não devem ser eliminados juntamente com os resíduos domésticos em geral.

O procedimento correto consiste no tratamento, recuperação e reciclagem de produtos usados, pelo que deve proceder à respetiva entrega nos pontos de recolha adequados, em conformidade com a legislação nacional em vigor.

A eliminação destes produtos de forma adequada permite poupar recursos valiosos e evitar potenciais efeitos prejudiciais para a saúde pública e para o ambiente, associados ao processamento incorreto dos resíduos.

Para mais informações relativas à recolha e reciclagem de produtos usados, contacte as autoridades locais, o serviço de eliminação de resíduos ou o ponto de venda onde foram adquiridos os itens relevantes.

#### Informações para utilizadores empresariais na União Europeia:

Para proceder à eliminação de equipamento elétrico e eletrónico, contacte o seu revendedor ou fornecedor para obter informações adicionais.

#### Informações relativas à eliminação em países não pertencentes à União Europeia:

Este símbolo é válido exclusivamente na União Europeia. Caso pretenda eliminar este tipo de itens, contacte as autoridades locais ou o seu revendedor e informe-se acerca do procedimento correto para proceder à respetiva eliminação.

(weee\_eu\_pt\_02a)

### Informations concernant la collecte et le traitement des déchets d'équipements électriques et électroniques



Le symbole sur les produits, l'emballage et/ou les documents joints signifie que les produits électriques ou électroniques usagés ne doivent pas être mélangés avec les déchets domestiques habituels.

Pour un traitement, une récupération et un recyclage appropriés des déchets d'équipements électriques et électroniques, veuillez les déposer aux points de collecte prévus à cet effet, conformément à la réglementation nationale.

En vous débarrassant correctement des déchets d'équipements électriques et électroniques, vous contribuerez à la sauvegarde de précieuses ressources et à la prévention de potentiels effets négatifs sur la santé humaine qui pourraient advenir lors d'un traitement inapproprié des déchets.

Pour plus d'informations à propos de la collecte et du recyclage des déchets d'équipements électriques et électroniques, veuillez contacter votre municipalité, votre service de traitement des déchets ou le point de vente où vous avez acheté les produits.

#### Pour les professionnels dans l'Union européenne :

Si vous souhaitez vous débarrasser des déchets d'équipements électriques et électroniques, veuillez contacter votre vendeur ou fournisseur pour plus d'informations.

#### Informations sur la mise au rebut dans d'autres pays en dehors de l'Union européenne :

Ce symbole est seulement valable dans l'Union européenne. Si vous souhaitez vous débarrasser de déchets d'équipements électriques et électroniques, veuillez contacter les autorités locales ou votre fournisseur et demander la méthode de traitement appropriée.

(weee\_eu\_fr\_02)

### Informazioni per gli utenti sulla raccolta e lo smaltimento di vecchia attrezzatura



Questi simboli sui prodotti, sull'imballaggio e/o sui documenti che li accompagnano, indicano che i prodotti elettrici ed elettronici non devono essere mischiati con i rifiuti generici.

Per il trattamento, il recupero e il riciclaggio appropriato di vecchi prodotti, si prega di portarli ai punti di raccolta designati, in accordo con la legislazione locale.

Smaltendo correttamente questi prodotti si potranno recuperare risorse preziose, oltre a prevenire potenziali effetti negativi sulla salute e l'ambiente che potrebbero sorgere a causa del trattamento improprio dei rifiuti.

Per ulteriori informazioni sulla raccolta e il riciclaggio di vecchi prodotti, si prega di contattare l'amministrazione comunale locale, il servizio di smaltimento dei rifiuti o il punto vendita dove sono stati acquistati gli articoli.

#### Per utenti imprenditori dell'Unione europea:

Se si desidera scartare attrezzatura elettrica ed elettronica, si prega di contattare il proprio rivenditore o il proprio fornitore per ulteriori informazioni.

#### Informazioni sullo smaltimento negli altri Paesi al di fuori dell'Unione europea:

Questi simboli sono validi solamente nell'Unione Europea; se si desidera scartare questi articoli, si prega di contattare le autorità locali o il rivenditore e richiedere informazioni sulla corretta modalità di smaltimento.

(weee\_eu\_it\_02)

- \* The contents of this manual apply to the latest specifications as of the publishing date. To obtain the latest manual, access the Yamaha website then download the manual file. Since specifications, equipment or separately sold accessories may not be the same in every locale, please check with your Yamaha dealer.
  
- \* Der Inhalt dieser Bedienungsanleitung gilt für die neuesten technischen Daten zum Zeitpunkt der Veröffentlichung. Um die neueste Version der Anleitung zu erhalten, rufen Sie die Website von Yamaha auf und laden Sie dann die Datei mit der Bedienungsanleitung herunter. Da die Technischen Daten, das Gerät selbst oder gesondert erhältliches Zubehör nicht in jedem Land gleich sind, setzen Sie sich im Zweifel bitte mit Ihrem Yamaha-Händler in Verbindung.
  
- \* Le contenu de ce mode d'emploi s'applique aux dernières caractéristiques techniques connues à la date de publication du manuel. Pour obtenir la version la plus récente du manuel, accédez au site Web de Yamaha puis téléchargez le fichier du manuel concerné. Étant donné que les caractéristiques techniques, les équipements et les accessoires vendus séparément varient d'un pays à l'autre, adressez-vous pour cela à votre distributeur Yamaha.
  
- \* El contenido de este manual se aplica a las últimas especificaciones según la fecha de publicación. Para obtener el último manual, acceda al sitio web de Yamaha y descargue el archivo del manual. Puesto que las especificaciones, los equipos o los accesorios que se vendan aparte podrían no ser iguales en todos los sitios, consulte al distribuidor de Yamaha.
  
- \* O conteúdo deste manual se aplica às especificações mais recentes a partir da data de publicação. Para obter o manual mais recente, acesse o site da Yamaha e faça o download do arquivo do manual. Como as especificações, os equipamentos ou os acessórios vendidos separadamente podem não ser iguais em todas as localidades; consulte o revendedor Yamaha.
  
- \* Il contenuto del presente manuale si applica alle ultime specifiche tecniche a partire dalla data di pubblicazione. Per ottenere la versione più recente del manuale, accedere al sito Web Yamaha e scaricare il file corrispondente. Dal momento che le specifiche tecniche, le apparecchiature e gli accessori venduti separatamente potrebbero variare a seconda del paese in cui viene distribuito il prodotto, verificarli con il rivenditore Yamaha.
  
- \* В содержании данного руководства приведены последние на момент публикации технические характеристики. Для получения последней версии руководства посетите веб-сайт корпорации Yamaha и загрузите файл с руководством. Так как технические характеристики, оборудование и отдельно продаваемые принадлежности могут различаться в разных странах, обратитесь за информацией к представителю корпорации Yamaha в своем регионе.
  
- \* この取扱説明書では、発行時点の最新仕様で説明をしております。最新版の取扱説明書につきましては、ヤマハウェブサイトからダウンロードして読みいただけますようお願いいたします。

이 기기는 가정용(B급) 전자파적합기기로서 주로 가정에서 사용하는 것을 목적으로 하며, 모든 지역에서 사용할 수 있습니다.

(class b korea)

# Specifications

Model	HS8	HS8I	HS7	HS7I	HS5	HS5I	HS8S
<b>General Specifications</b>							
Type	Bi-amp 2-way powered speaker						Powered subwoofer
Crossover Frequency	2 kHz						-
Overall Frequency Response	-3dB	47 Hz – 24 kHz		55 Hz – 24 kHz		74 Hz – 24 kHz	
	-10dB	38 Hz – 30 kHz		43 Hz – 30 kHz		54 Hz – 30 kHz	
Mounting Points	-	Four surfaces x 2 x M8 (120 mm pitch)		-	Four surfaces x 2 x M8 (120 mm pitch)		-
Dimensions (W x H x D)	250 x 390 x 334 mm 9-13/16 x 15-3/8 x 13-1/8"		210 x 332 x 284 mm 8-1/4 x 13-1/16 x 11-3/16"		170 x 285 x 222 mm 6-11/16 x 11-1/4 x 8-3/4"		300 x 350 x 389 mm 11-13/16 x 13-3/4 x 15-5/16"
Weight	10.2 kg (22.5 lb.)	10.7 kg (23.6 lb.)	8.2 kg (18.1 lb.)	8.7 kg (19.2 lb.)	5.3 kg (11.7 lb.)	5.5 kg (12.1 lb.)	12.5 kg (27.6 lb.)
<b>Speaker Components</b>							
Speaker Components	LF: 8" cone HF: 1" dome		LF: 6.5" cone HF: 1" dome		LF: 5" cone HF: 1" dome		8" cone
Enclosure	Bass-reflex type, Material: MDF						
<b>Amplifier Unit</b>							
Output Power	Total	120 W (dynamic power)		95 W (dynamic power)		70 W (dynamic power)	
	LF	75 W (4 ohms)		60 W (4 ohms)		45 W (4 ohms)	
	HF	45 W (8 ohms)		35 W (8 ohms)		25 W (8 ohms)	
Input Sensitivity / Impedance	-10 dBu/10k ohms						
Output Level/Impedance	-						-10 dBu/600 ohms
Input Connectors (Parallel)	1: XLR-3-31 type (balanced) 2: PHONE (balanced)						
Output Connectors	-						XLR-3-32 type (balanced) x2 (L&R)
Controls	LEVEL control (+4 dB, center click) EQ: HIGH TRIM switch (+/- 2 dB at HF), ROOM CONTROL switch (0/-2/-4 dB under 500Hz)						LEVEL control PHASE switch (NORM./REV.) HIGH CUT control (80 – 120 Hz, center click) LOW CUT control (80 – 120 Hz, center click) LOW CUT switch (ON/OFF)
Indicator	Power ON (White LED)						
Power Consumption	60 W		55 W		45 W		70 W

# Dimensions

## HS8/HS8I

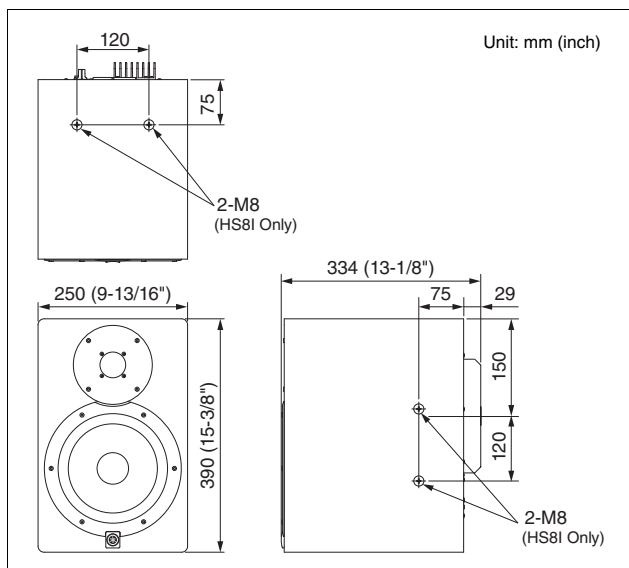

## HS7/HS7I

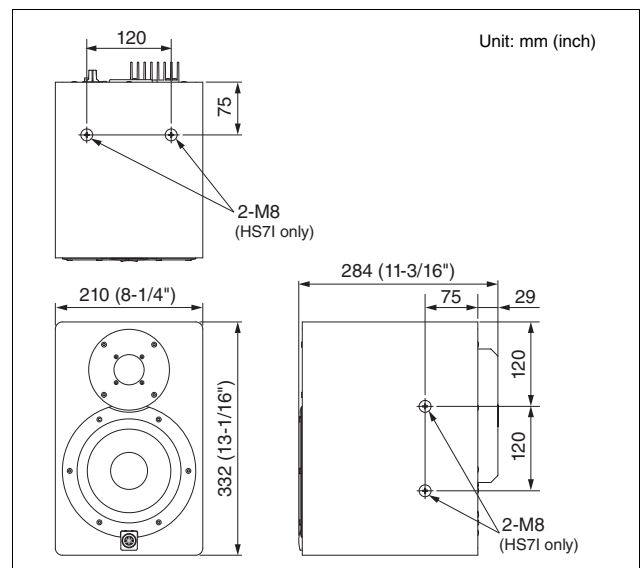

English

Deutsch

Français

Español

Português

Italiano

Русский

日本語

## HS5/HS5I

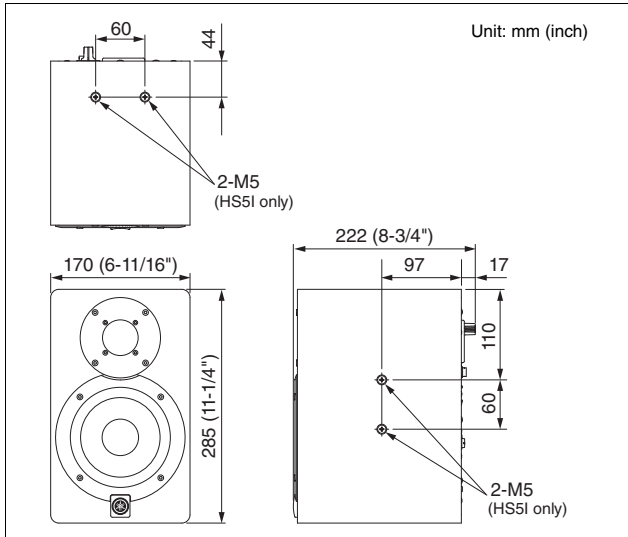

## HS8S

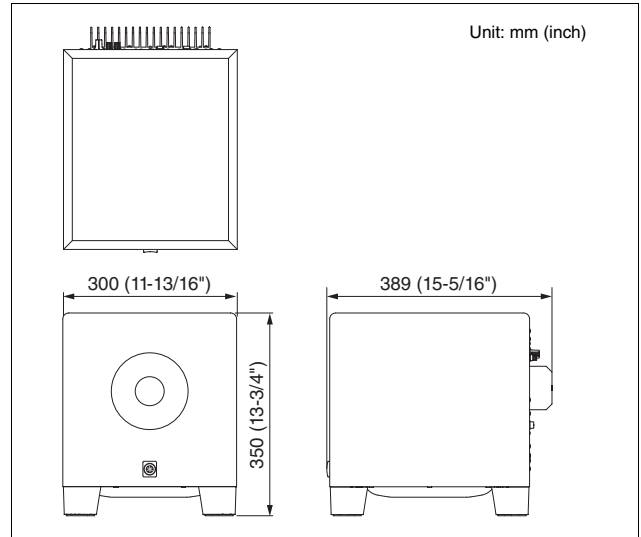

# Performance Graph

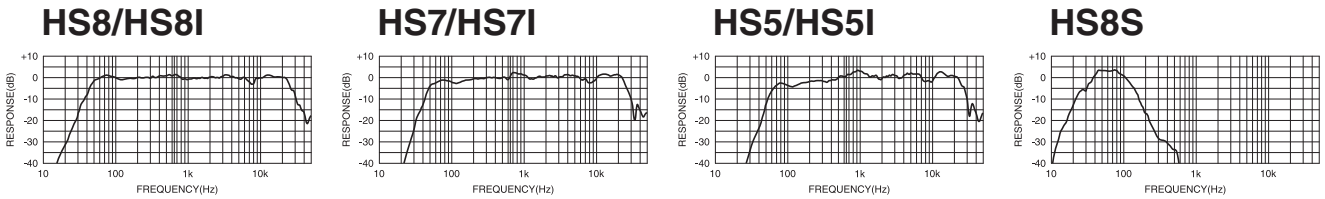

# Block Diagram

## HS8/HS7/HS5 HS8I/HS7I/HS5I

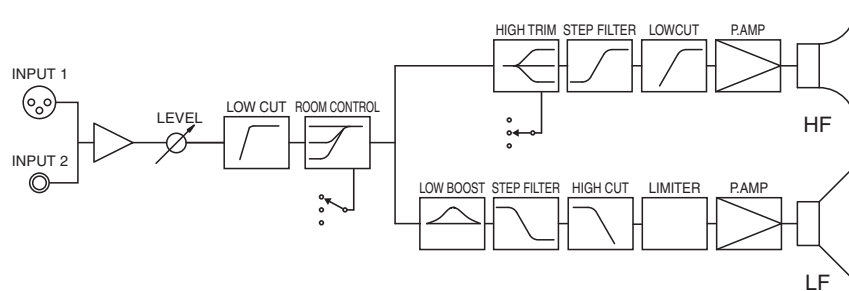

## HS8S

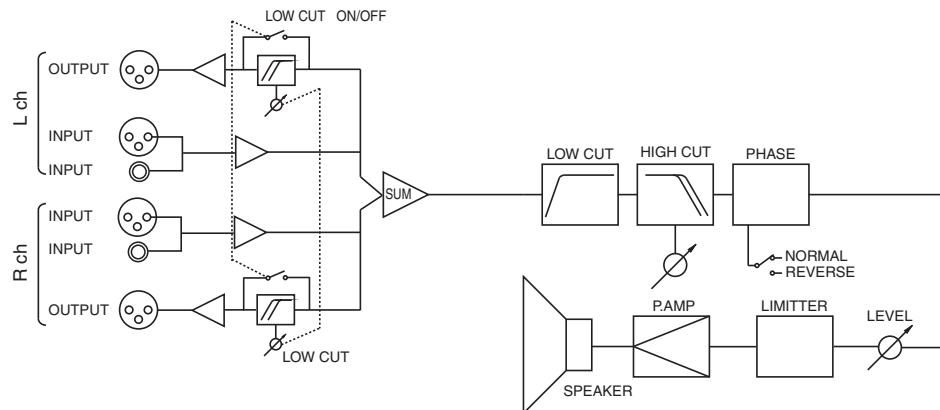

# Tilt Angle (HS8I/HS7I/HS5I only)

Wall mount

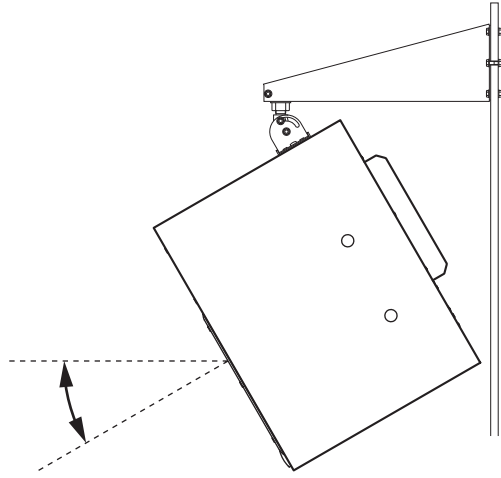

Ceiling mount

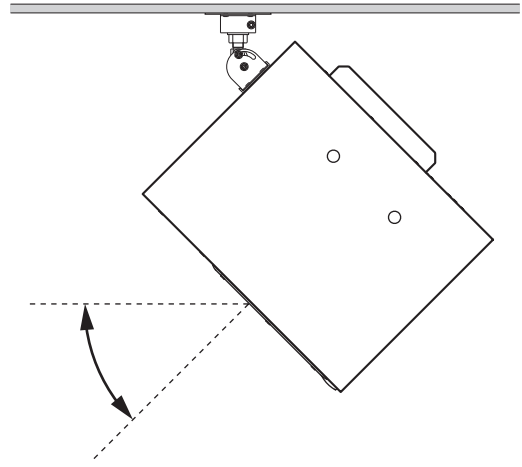

You can use third-party bracket sold separately.  
For information on available third-party bracket, please refer to the Yamaha Pro Audio website.  
<https://www.yamahaproaudio.com/>

English

Deutsch

Français

Español

Português

Italiano

Русский

日本語

# Important Notice: Guarantee Information for customers in European Economic Area (EEA) and Switzerland

<b>Important Notice: Guarantee Information for customers in EEA* and Switzerland</b>	<b>English</b>
For detailed guarantee information about this Yamaha product, and Pan-EEA* and Switzerland warranty service, please either visit the website address below (Printable file is available at our website) or contact the Yamaha representative office for your country. * EEA: European Economic Area	
<b>Wichtiger Hinweis: Garantie-Information für Kunden in der EWR* und der Schweiz</b>	<b>Deutsch</b>
Für nähere Garantie-Information über dieses Produkt von Yamaha, sowie über den Pan-EWR*- und Schweizer Garantieservice, besuchen Sie bitte entweder die folgend angegebene Internetadresse (eine druckfähige Version befindet sich auch auf unserer Webseite), oder wenden Sie sich an den für Ihr Land zuständigen Yamaha-Vertrieb. *EWR: Europäischer Wirtschaftsraum	
<b>Remarque importante: informations de garantie pour les clients de l'EEE et la Suisse</b>	<b>Français</b>
Pour des informations plus détaillées sur la garantie de ce produit Yamaha et sur le service de garantie applicable dans l'ensemble de l'EEE ainsi qu'en Suisse, consultez notre site Web à l'adresse ci-dessous (le fichier imprimable est disponible sur notre site Web) ou contactez directement Yamaha dans votre pays de résidence. * EEE : Espace Economique Européen	
<b>Belangrijke mededeling: Garantie-informatie voor klanten in de EER* en Zwitserland</b>	<b>Nederlands</b>
Voor gedetailleerde garantie-informatie over dit Yamaha-product en de garantieservice in heel de EER* en Zwitserland, gaat u naar de onderstaande website (u vindt een afdrukbaar bestand op onze website) of neemt u contact op met de vertegenwoordiging van Yamaha in uw land. * EER: Europese Economische Ruimte	
<b>Aviso importante: información sobre la garantía para los clientes del EEE* y Suiza</b>	<b>Español</b>
Para una información detallada sobre este producto Yamaha y sobre el soporte de garantía en la zona EEE* y Suiza, visite la dirección web que se incluye más abajo (la versión del archivo para imprimir esta disponible en nuestro sitio web) o póngase en contacto con el representante de Yamaha en su país. * EEE: Espacio Económico Europeo	
<b>Avviso importante: informazioni sulla garanzia per i clienti residenti nell'EEA* e in Svizzera</b>	<b>Italiano</b>
Per informazioni dettagliate sulla garanzia relativa a questo prodotto Yamaha e l'assistenza in garanzia nei paesi EEA* e in Svizzera, potete consultare il sito Web all'indirizzo riportato di seguito (è disponibile il file in formato stampabile) oppure contattare l'ufficio di rappresentanza locale della Yamaha. * EEA: Area Economica Europea	
<b>Aviso importante: informações sobre as garantias para clientes da AEE* e da Suíça</b>	<b>Português</b>
Para obter uma informação pormenorizada sobre este produto da Yamaha e sobre o serviço de garantia na AEE* e na Suíça, visite o site a seguir (o arquivo para impressão está disponível no nosso site) ou entre em contato com o escritório de representação da Yamaha no seu país. * AEE: Área Económica Européia	
<b>Σημαντική σημείωση: Πληροφορίες εγγύησης για τους πελάτες στον ΕΟΧ* και Ελλάδα</b>	<b>Ελληνικά</b>
Για λεπτομερείς πληροφορίες εγγύησης σχετικά με το παρόν προϊόν της Yamaha και την κάλυψη εγγύησης σε όλες τις χώρες του ΕΟΧ και την Ελλάδα, επισκεφτείτε την παρακάτω ιστοσελίδα (Εκτυπώσιμη μορφή είναι διαθέσιμη στην ιστοσελίδα μας) ή απευθυνθείτε στην αντιπροσωπεία της Yamaha στη χώρα σας. * ΕΟΧ: Ευρωπαϊκός Οικονομικός Χώρος	
<b>Viktigt: Garantiinformation för kunder i EES-området* och Schweiz</b>	<b>Svenska</b>
För detaljerad information om denna Yamahaprodukt samt garantiservice i hela EES-området* och Schweiz kan du antingen besöka nedanstående webbadress (en utskriftsvänlig fil finns på webbplatsen) eller kontakta Yamahas officiella representant i ditt land. * EES: Europeiska Ekonomiska Samarbetsområdet	
<b>Viktig merknad: Garantiinformasjon for kunder i EØS* og Sveits</b>	<b>Norsk</b>
Detaljert garantiinformasjon om dette Yamaha-produktet og garantiservice for hele EØS-området* og Sveits kan fås enten ved å besøke nettstedene nedenfor (utskriftsversjon finnes på våre nettsider) eller kontakte Yamahas kontoret i landet der du bor. *EØS: Det europeiske økonomiske samarbeidsområdet	
<b>Vigtig oplysning: Garantioplysninger til kunder i EØ* og Schweiz</b>	<b>Dansk</b>
De kan finde detaljerede garantioplysninger om dette Yamaha-produkt og den fælles garantiserviceordning for EØ* (og Schweiz) ved at besøge det websted, der er angivet nedenfor (der findes en fil, som kan udskrives, på vores websted), eller ved at kontakte Yamahas nationale repræsentationskontor i det land, hvor De bor. * EØ: Det Europæiske Økonomiske Område	
<b>Tärkeä ilmoitus: Takuutiedot Euroopan talousalueen (ETA)* ja Sveitsin asiakkaille</b>	<b>Suomi</b>
Tämän Yamaha-tuotteen sekä ETA-alueen ja Sveitsin takuuta koskevat yksityiskohtaiset tiedot saatte alla olevasta nettiosoitteesta. (Tulostettava tiedosto saatavissa sivustollamme.) Voititte myös ottaa yhteyttä paikalliseen Yamaha-edustajaan. *ETA: Euroopan talousalue	
<b>Ważne: Warunki gwarancyjne obowiązujące w EOG* i Szwajcarii</b>	<b>Polski</b>
Aby dowiedzieć się więcej na temat warunków gwarancyjnych tego produktu firmy Yamaha i serwisu gwarancyjnego w całym EOG* i Szwajcarii, należy odwiedzić wskazaną poniżej stronę internetową (Plik gotowy do wydruku znajduje się na naszej stronie internetowej) lub skontaktować się z przedstawicielstwem firmy Yamaha w swoim kraju. * EOG — Europejski Obszar Gospodarczy	
<b>Důležité oznámení: Záruční informace pro zákazníky v EHS* a ve Švýcarsku</b>	<b>Česky</b>
Podrobné záruční informace o tomto produktu Yamaha a záručním servisu v celém EHS* a ve Švýcarsku naleznete na níže uvedené webové adrese (soubor k tisku je dostupný na našich webových stránkách) nebo se můžete obrátit na zastoupení firmy Yamaha ve své zemi. * EHS: Evropský hospodářský prostor	
<b>Fontos figyelemztetés: Garancia-információk az EGT* területén és Svájcban élő vásárlók számára</b>	<b>Magyar</b>
A jelen Yamaha termékre vonatkozó részletes garancia-információk, valamint az EGT*-re és Svájcra kiterjedő garanciális szolgáltatás tekintetében keresse fel webhelyünket az alábbi címen (a webhelyen nyomtatható fájl is található), vagy pedig lépjen kapcsolatba az országában működő Yamaha képviselői irodával. * EGT: Európai Gazdasági Térség	
<b>Oluline märkus: Garantiiteave Euroopa Majanduspiirkonna (EMP)* ja Šveitsi klientidele</b>	<b>Eesti keel</b>
Täpsemate teabe saamiseks selle Yamaha toote garantii ning kogu Euroopa Majanduspiirkonna ja Šveitsi garantiiteeninduse kohta, külastage palun veebisaiti alljärgneval aadressil (meie saidil on saadaval prinditav fail) või pöörduge Teie regiooni Yamaha esinduse poole. * EMP: Euroopa Majanduspiirkond	
<b>Svarīgs paziņojums: garantijas informācija klientiem EEZ* un Šveicē</b>	<b>Latviešu</b>
Lai saņemtu detalizētu garantijas informāciju par šo Yamaha produktu, kā arī garantijas apkalpošanu EEZ* un Šveicē, lūdzu, apmeklējiet zemāk norādīto tīmekļa vietnes adresi (tīmekļa vietnē ir pieejams drukājams fails) vai sazinieties ar jūsu valsti apkalpojošo Yamaha pārstāvniecību. * EEZ: Eiropas Ekonomikas zona	
<b>Dėmesio: informacija dėl garantijos pirkėjams EEE* ir Šveicarijoje</b>	<b>Lietuvių kalba</b>
Jei reikia išsamios informacijos apie šį „Yamaha“ produktą ir jo techninę priežiūrą visoje EEE* ir Šveicarijoje, apsilankykite mūsų svetainėje toliau nurodytu adresu (svetainėje yra spausdintinas failas) arba kreipkitės į „Yamaha“ atstovybę savo šaliai. *EEE – Europos ekonominė erdvė	
<b>Dôležité upozornenie: Informácie o záruke pre zákazníkov v EHP* a Švajčiarsku</b>	<b>Slovenčina</b>
Podrobné informácie o záruke týkajúce sa tohto produktu od spoločnosti Yamaha a garančnom servise v EHP* a Švajčiarsku nájdete na webovej stránke uvedenej nižšie (na našej webovej stránke je k dispozícii súbor na tlač) alebo sa obráťte na zástupcu spoločnosti Yamaha vo svojej krajine. * EHP: Európsky hospodársky priestor	
<b>Pomembno obvestilo: Informacije o garanciji za kupce v EGP* in Švici</b>	<b>Slovenščina</b>
Za podrobnejše informacije o tem Yamahinem izdelku ter garancijskem servisu v celotnem EGP in Švici, obiščite spletno mesto, ki je navedeno spodaj (natisljiva datoteka je na voljo na našem spletnem mestu), ali se obrnite na Yamahinega predstavnika v svoji državi. * EGP: Evropski gospodarski prostor	
<b>Важно съобщение: Информация за гаранцията за клиенти в ЕИП* и Швейцария</b>	<b>Български език</b>
За подробна информация за гаранцията за този продукт на Yamaha и гаранционното обслужване в паневропейската зона на ЕИП* и Швейцария или посетете посочения по-долу уеб сайт (на нашия уеб сайт има файл за печат), или се свържете с представителния офис на Yamaha във вашата страна. * ЕИП: Европейско икономическо пространство	
<b>Notificare importantă: Informații despre garanție pentru clienții din SEE* și Elveția</b>	<b>Limba română</b>
Pentru informații detaliate privind acest produs Yamaha și serviciul de garanție Pan-SEE* și Elveția, vizitați site-ul la adresa de mai jos (fișierul imprimabil este disponibil pe site-ul nostru) sau contactați biroul reprezentanței Yamaha din țara dumneavoastră. * SEE: Spațiul Economic European	
<b>Važna obavijest: Informacije o jamstvu za države EGP-a i Švicarske</b>	<b>Hrvatski</b>
Za detaljne informacije o jamstvu za ovaj Yamahin proizvod te jamstvenom servisu za cijeli EGP i Švicarsku, molimo Vas da posjetite web-stranicu navedenu u nastavku ili kontaktirate ovlaštenog Yamahinog dobavljača u svojoj zemlji. * EGP: Evropski gospodarski prostor	

<https://europe.yamaha.com/warranty/>

# Yamaha Worldwide Representative Offices

## English

For details on the product(s), contact your nearest Yamaha representative or the authorized distributor, found by accessing the 2D barcode below.

## Deutsch

Wenden Sie sich für nähere Informationen zu Produkten an eine Yamaha-Vertretung oder einen autorisierten Händler in Ihrer Nähe. Diese finden Sie mithilfe des unten abgebildeten 2D-Strichodes.

## Français

Pour obtenir des informations sur le ou les produits, contactez votre représentant ou revendeur agréé Yamaha le plus proche. Vous le trouverez à l'aide du code-barres 2D ci-dessous.

## Español

Para ver información detallada sobre el producto, contacte con su representante o distribuidor autorizado Yamaha más cercano. Lo encontrará escaneando el siguiente código de barras 2D.

## Italiano

Per dettagli sui prodotti, contattare il rappresentante Yamaha o il distributore autorizzato più vicino, che è possibile trovare tramite il codice a barre 2D in basso.

## Português

Para mais informações sobre o(s) produto(s), fale com seu representante da Yamaha mais próximo ou com o distribuidor autorizado acessando o código de barras 2D abaixo.

## Русский

Чтобы узнать подробнее о продукте (продуктах), свяжитесь с ближайшим представителем или авторизованным дистрибьютором Yamaha, воспользовавшись двухмерным штрихкодом ниже.

## 简体中文

如需有关产品的详细信息，请联系距您最近的Yamaha代表或授权经销商，可通过访问下方的2D条形码找到这些代表或经销商的信息。

## 繁體中文

如需產品的詳細資訊，請聯絡與您距離最近的 Yamaha 銷售代表或授權經銷商，您可以掃描下方的二維條碼查看相關聯絡資料。

## 한국어

제품에 대한 자세한 정보는 아래 2D 바코드에 액세스하여 가까운 Yamaha 담당 판매점 또는 공식 대리점에 문의하십시오.



[https://manual.yamaha.com/pa/address\\_list/](https://manual.yamaha.com/pa/address_list/)

Yamaha Pro Audio global website  
<https://www.yamahaproaudio.com/>  
Yamaha Downloads  
<https://download.yamaha.com/>

© 2016 Yamaha Corporation  
Published 03/2024  
MWEI-D0



VHM5490