

MELTAZO Smart Skipping Rope
USER MANUAL (ENGLISH)





Bluetooth 4.0



No. of Skips



Calories



Average Speed



Time



Fat Burnt



Time Setting



Target



Ranking



Skipping PK

Battery Installation

Functional handle

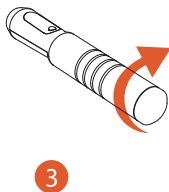
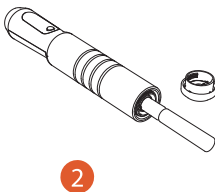
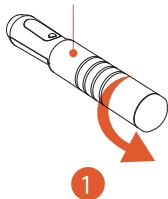

- 1) Open the battery cover of the functional handle,
- 2) Insert 2 pieces AAA Batteries; and
- 3) Close the battery cover.

※ If the red LED light is on, it means the battery has around 3% power left. Please replace the battery.

LCD Display & Rolling Handle

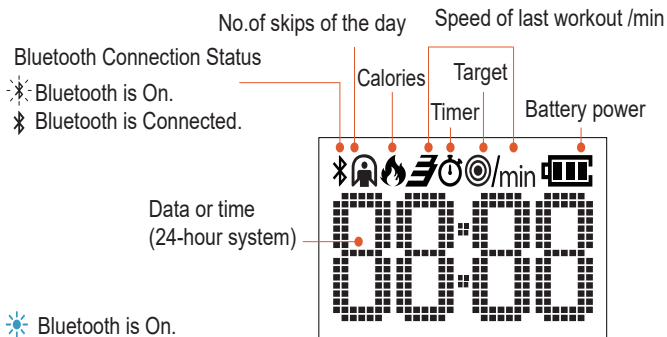

- Bluetooth is On.
- Bluetooth is Connected.
- Firmware is Upgrading.
- Low Power Alarm

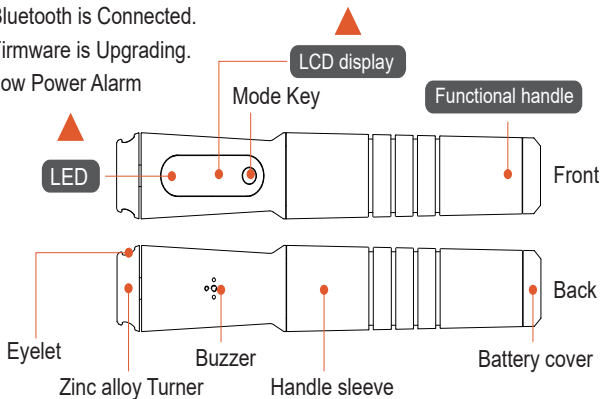

LCD Display Flow

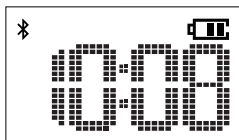

Time

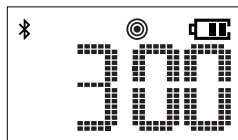

Target circle number

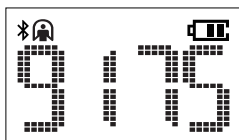

No. of skips

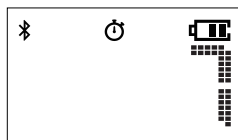

Time settings (minutes)

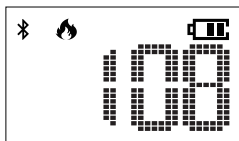

Calories

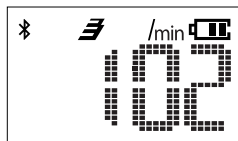

Speed /min

Training Target Manually Setting

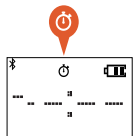
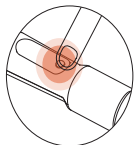

1) Setting Exercise Time as target:

Tap the Model Key, and icon --:-- appears, then long-press the Model Key, icon --:-- starts to flash. Tap the Key to set the exercise time as target (UOM: min). Long press to exit the setting mode. It displays 3-2-1 with three short sounds, then a long sound as a reminder of starting playing, and it will automatically count down. When meeting the target, the smart rope will play three short sounds as a reminder of completion of the target. The LCD display will automatically show the exercise's number of skips.

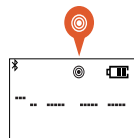

2) Setting Skips No. as Target:

Tap the Model Key, and icon ---- appears, then long-press the Model Key, icon starts to flash. Tap the Key to set the exercise skips number as target (Minimum 100, maximum 2000). Long press to exit the setting mode. It displays 3-2-1 with three short sounds, then a long sound as a reminder of starting playing, and it will automatically count down. When meeting the target, the smart rope will play three short sounds as a reminder of completion of the target. The LCD display will automatically show the exercising time.



Wozuil



Scan the QR code on the gift box, and visit the official website (www.wozuil.com), click the download button for app download, or search the "wozuil" in the APP Store for app download. Install the app and start the trip of rope skipping for fitness.



www.wozuil.com

iOS

System Requirement:
iOS7 and above

Android

System Requirement:
Android 4.3 and above

BLUETOOTH 4.0

Login



← 忘记密码? 注册



- 1) Besides Registration, it allows multiple methods to login.
- 2) If you forget your password, please click to retrieve it by entering the serial number on the skipping handle.

Bluetooth Connection

- 1) Turn on the Bluetooth on your mobile phone.
- 2) The Bluetooth icon starts to flash when the screen is bright.
- 3) On the App Device Management page in the app, search and find model No.: wozuil xxx, then click it for connection.

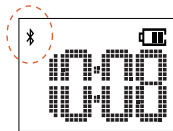

Ranking List

It's convenient to check the Jumping Ranking through the Wozuil app.

The user can open the App and synchronize the data of the day to the Server, then the exercise data will be updated to the Ranking List.

Through friends' encouragement, it will motivate the enthusiasm of exercise.

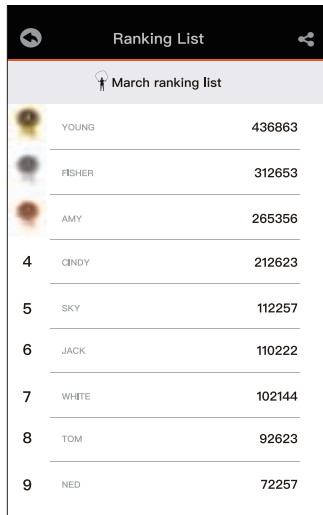

The screenshot shows a mobile application interface for a 'Ranking List'. At the top, there is a navigation bar with a back arrow on the left, the title 'Ranking List' in the center, and a share icon on the right. Below the navigation bar is a header section with a lightbulb icon and the text 'March ranking list'. The main content area displays a list of names and their corresponding scores, separated by horizontal lines. The list is ordered from highest to lowest score.

	YOUNG	436863
	FISHER	312653
	AMY	265356
4	CINDY	212623
5	SKY	112257
6	JACK	110222
7	WHITE	102144
8	TOM	92623
9	NED	72257

Buddy PK

The users of the Wozuil Smart Rope can form a group of maximumly 6 people, and set exercise time to PK among friends.

Through PK, it can bring joyfulness, stimulate competition, potential, and better achieve the purpose of the workout, sports, and fitness.

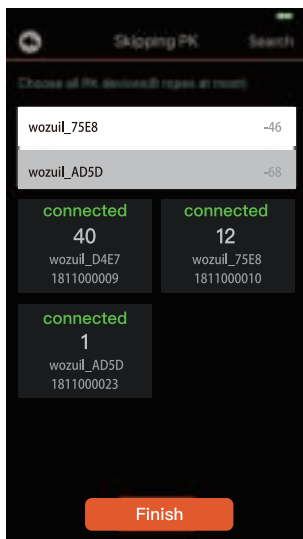

Product Parameters

Product name	Smart skipping rope
Connection type	Bluetooth 4.0
Synchronization range	About 10 meters
Handle size	34 x 34 x 192mm
Handle material	ABS, Zinc alloy, PMMA & EVA
Length adjustment	Adjustable
Rope material	TPU-coated wire rope
Weight	About 300 grams (including batteries)
Display	LCD
Lighting	RGB LED
Battery	2 pieces AAA Batteries
Standby time	One year
Axis type	Bearing
Record	Daily rope skipping data for the past 14 days
Product includes	Handles, skipping ropes, and a user manual

NOTE: Batteries are NOT included in the product box.



Meltazo[®]

Incredible Possibilities



<https://meltazo.com>

Thank you very much for purchasing one of our favorite products.



"Scan here to watch how to install & use our Smart Rope"





Meltazo®

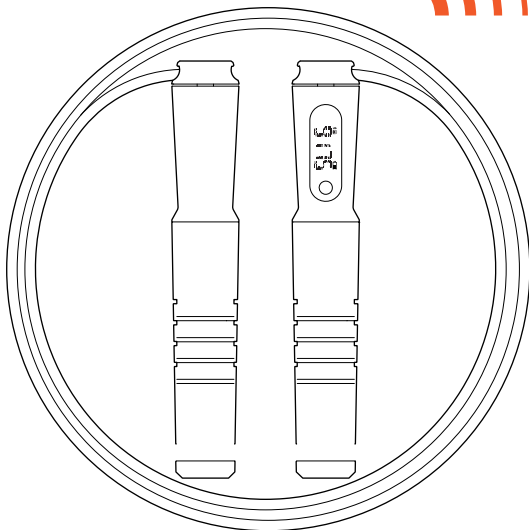

MELTAZO Slim Springtouw

GEBRUIKERSHANDLEIDING (NEDERLANDS)





Bluetooth 4.0



Aantal Sprongen



Calorieën



Gemiddelde Snelheid



Tijd



Vetverbranding



Tijd Instelling



Doel



Rangschikking



Sprong PK

Batterij Installatie

Functionele handgreep

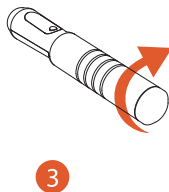
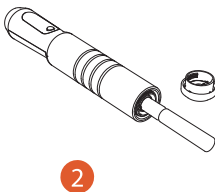
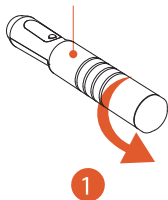

- 1) Open het batterijklepje van de functionele handgreep,
- 2) Plaats 2 stuks AAA-batterijen, en
- 3) Sluit het batterijklepje.

※ Als het rode LED-lampje brandt, betekent dit dat de batterij nog ongeveer 3% over heeft. Vervang de batterij a.u.b.

LCD-scherm & Rolhandvat

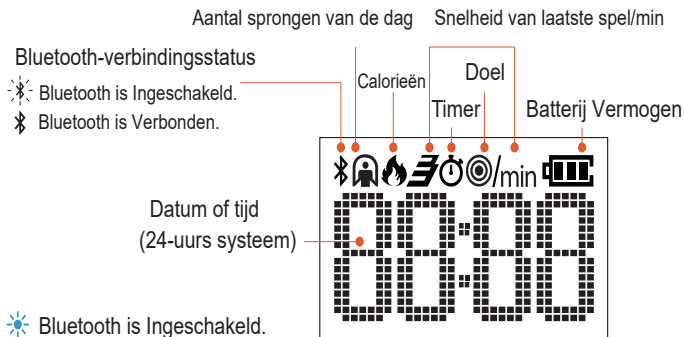

Bluetooth is Ingeschakeld.

Bluetooth is Verbonden.

Firmware wordt Geüpgraded.

Alarm voor Laag Vermogen

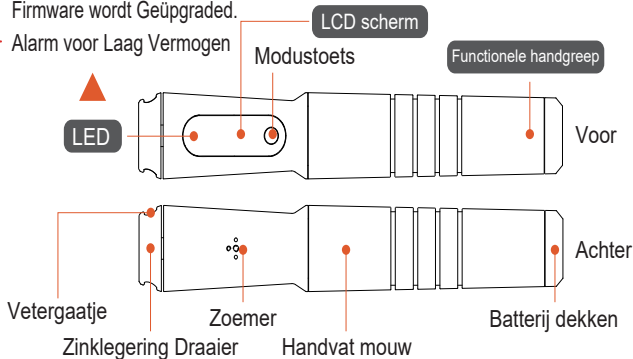

Stroom van LCD-scherm

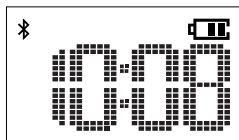

Tijd

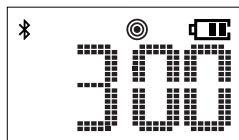

Nummer van doelcirkel

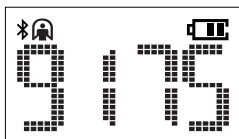

Aantal Sprongen

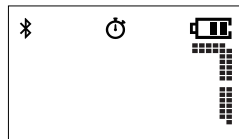

Tijdinstellingen (minuten)

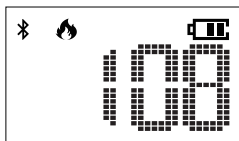

Calorieën

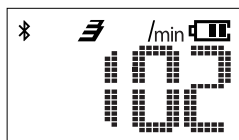

Snelheid /min.

Trainingsdoel Handmatig Instellen

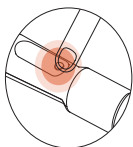

1) Trainingstijd Instellen als Doel:

Tik op de modeltoets en het pictogram --:-- verschijnt, druk vervolgens lang op de modeltoets, het pictogram --:-- begint te knippen. Tik op de toets om de trainingstijd als doel in te stellen (UOM: min). Lang indrukken om de instellingsmodus te verlaten. Het geeft 3-2-1 weer met drie korte geluiden, dan een lang geluid als herinnering om te beginnen met spelen, en het zal automatisch aftellen. Wanneer het doel wordt bereikt, zal het slimme touw drie korte geluiden spelen als herinnering aan het voltooien van het doel. Op het LCD-scherm wordt automatisch het aantal overgeslagen oefeningen weergegeven.

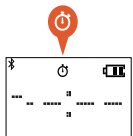

2) Sprong Nummer Instellen als Doel:

Tik op de modeltoets en het pictogram ---- verschijnt, druk vervolgens lang op de modeltoets, het pictogram begint te knippen. Tik op de toets om het aantal overgeslagen oefeningen als doel in te stellen (minimaal 100, maximaal 2000). Lang indrukken om de instellingsmodus te verlaten. Het geeft 3-2-1 weer met drie korte geluiden, dan een lang geluid als herinnering om te beginnen met spelen, en het zal automatisch aftellen. Wanneer het doel wordt bereikt, zal het slimme touw drie korte geluiden spelen als herinnering aan het voltooien van het doel. Op het LCD-scherm wordt automatisch de trainingstijd weergegeven.

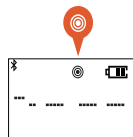



Wozuil



Scan de QR-code op de geschenkverpakking en bezoek de officiële website (www.wozuil.com), klik op de downloadknop om de app te downloaden of zoek in de APP Store naar de app 'wozuil'. Installeer de app en start de trip van touwtjespringen voor fitness.



www.wozuil.com

iOS

Systeemvereiste:
iOS 7 en hoger

Android

Systeemvereiste:
Android 4.3 en hoger

BLUETOOTH 4.0

Log in



← Scan QR Code with App



- 1) Naast Registratie zijn er meerdere manieren om in te loggen.
- 2) Als u uw wachtwoord bent vergeten, klik dan om het op te halen door het serienummer op de springhandgreep in te voeren.

Bluetooth-Verbonden

- 1) Zet Bluetooth aan op je mobiele telefoon.
- 2) Het Bluetooth-pictogram begint te knipperen wanneer het scherm helder is.
- 3) Zoek en vind op de App Device Management-pagina in de app het modelnr.: wozuil xxx en klik erop om verbinding te maken.

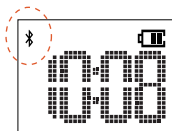

Ranglijst

Het is handig om de Springranglijst te bekijken via de Wozuil app.

De gebruiker kan de app openen en de gegevens van de dag synchroniseren met de server, waarna de trainingsgegevens worden bijgewerkt naar de ranglijst.

Door de aanmoediging van vrienden zal het enthousiasme van de oefening motiveren.

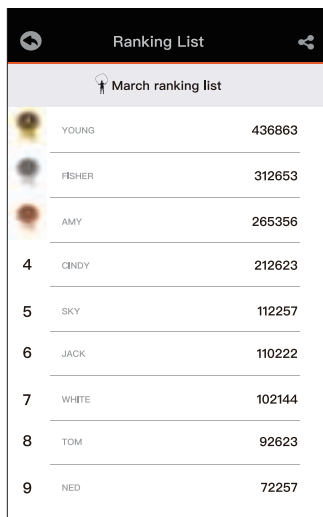

The screenshot shows a mobile application interface titled 'Ranking List'. Below the title bar, there is a subtitle 'March ranking list' with a lightbulb icon. The main content is a list of names and their corresponding scores, separated by horizontal lines. The list is ordered from highest to lowest score.

	YOUNG	436863
	FISHER	312653
	AMY	265356
4	CINDY	212623
5	SKY	112257
6	JACK	110222
7	WHITE	102144
8	TOM	92623
9	NED	72257

Makker PK

De gebruikers van het Wozuil Slim Touw kunnen een groep vormen van maximaal 6 personen en onder vrienden oefentijd op PK instellen.

Door PK kan het vreugde brengen, concurrentie en potentieel stimuleren en het doel van training, sport en fitness beter bereiken.

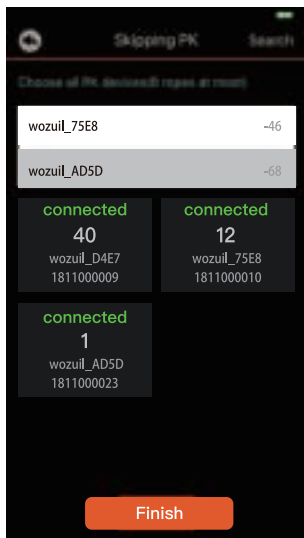

Productparameters

Productnaam	Slim springtouw
Verbindingstype	Bluetooth 4.0
Synchronisatiebereik	Ongeveer 10 meter
Handvat Maat	34 x 34 x 192mm
Materiaal handvat	ABS, Zinklegering, PMMA & EVA
Lengteverstelling	Verstelbaar
Touw materiaal	TPU-gecoate staalkabel
Gewicht	Ongeveer 300 gram (inclusief batterijen)
Display	LCD
Verlichting	RGB-LED
Batterij	2 stuks AAA-batterijen
Standby-tijd	Een jaar
Astype	Lager
Record	Dagelijkse gegevens over touwtjespringen van de afgelopen 14 dagen
Product bevat	Handvatten, springtouwen en een gebruikershandleiding

LET OP: Batterijen zijn niet inbegrepen in de productdoos.



Meltazo[®]

Incredible Possibilities



<https://meltazo.com>

Hartelijk dank voor het kopen van een van onze favoriete producten.



"Scan hier om te zien hoe je ons Slim Touw installeren en gebruikt"





Meltazo®

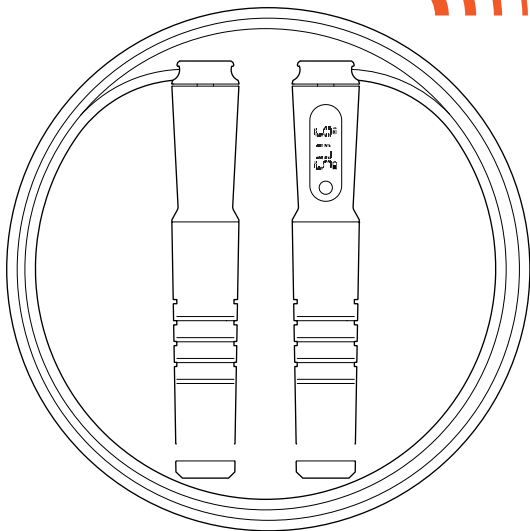

Corde à sauter intelligente MELTAZO
MANUEL D'UTILISATION (FRANÇAIS)





Bluetooth 4.0



Nombre de Sauts



Calories



Vitesse Moyenne



Temps



La graisse brûlée



Réglage de l'heure



Objectif



Classement



Saut PK

Installation de la Batterie

Poignée fonctionnelle

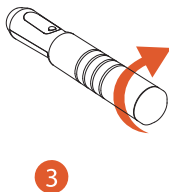
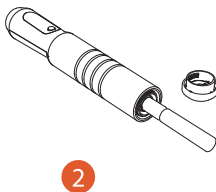
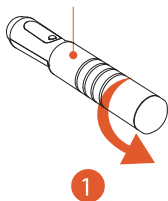

- 1) Ouvrez le couvercle des piles de la poignée fonctionnelle,
- 2) Insérez 2 piles AAA, et
- 3) Fermez le couvercle des piles.

※ Si le voyant LED rouge est allumé, cela signifie que la batterie a environ 3% de puissance restante. Veuillez remplacer la batterie.

Affichage LCD & Poignée Roulante

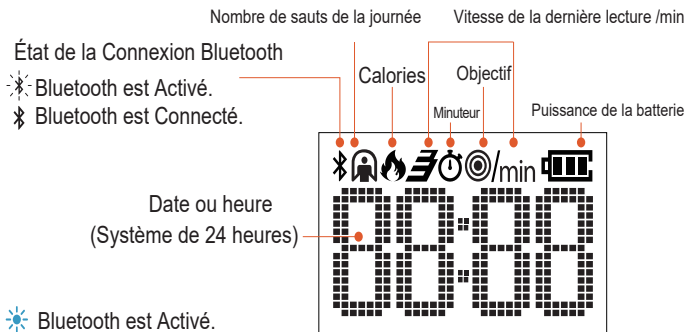

Bluetooth est Activé.

Bluetooth est Connecté.

Le micro logiciel est en cours de mise à niveau.

Alarme de faible puissance

Affichage LCD

Touche de mode

Poignée fonctionnelle

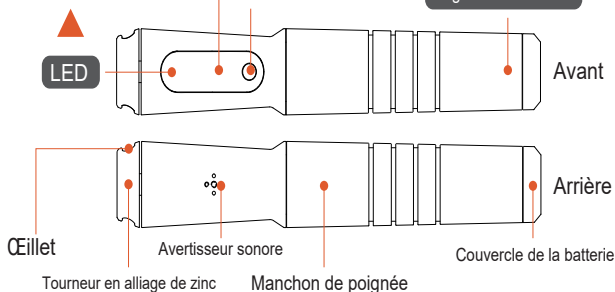

Flux D'affichage LCD

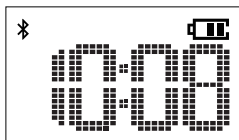

Temps

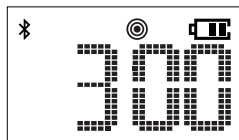

Numéro du cercle cible

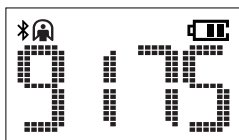

Nombre de sauts

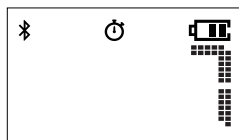

Réglages de l'heure (minutes)

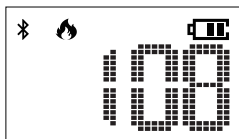

Calories

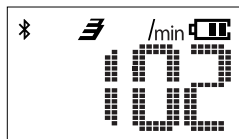

Vitesse /min

Réglage Manuel de L'objectif D'entraînement

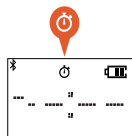
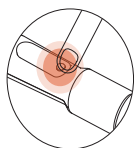

1) Définir la Durée de L'exercice comme Objectif:

Appuyez sur la touche du modèle et l'icône --:-- apparaît, puis appuyez longuement sur la touche du modèle, l'icône --:-- commence à clignoter. Appuyez sur la touche pour définir la durée de l'exercice comme objectif (UOM : min). Appuyez longuement pour quitter le mode de réglage. Il affiche 3-2-1 avec trois sons courts, puis un son long comme rappel pour commencer à jouer, et il décomptera automatiquement. Lorsqu'elle atteint l'objectif, la corde intelligente jouera trois sons courts comme rappel de l'achèvement de l'objectif. L'écran LCD affichera automatiquement le nombre de sauts d'exercice.

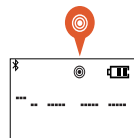

2) N° de Sauts en tant qu'Objectif:

Appuyez sur la touche du modèle et l'icône ---- apparaît, puis appuyez longuement sur la touche du modèle, l'icône ---- commence à clignoter. Appuyez sur la touche pour définir le nombre de sauts d'exercice comme objectif (Minimum 100, maximum 2000). Appuyez longuement pour quitter le mode de réglage. Il affiche 3-2-1 avec trois sons courts, puis un son long pour rappeler de commencer à jouer, et il décomptera automatiquement. Lorsqu'elle atteint l'objectif, la corde intelligente jouera trois sons courts pour rappeler l'achèvement de l'objectif. L'écran LCD affichera automatiquement la durée de l'exercice.



Wozuil



Scannez le code QR sur le coffret cadeau et visitez le site Web officiel (www.wozuil.com), cliquez sur le bouton de téléchargement pour télécharger l'application ou recherchez le "wozuil" dans l'APP Store pour télécharger l'application. Installez l'application et commencez le voyage de corde à sauter pour le fitness.



www.wozuil.com

iOS

Configuration Require:
iOS7 et supérieur

Android

Configuration Require:
Android 4.3 et supérieur

BLUETOOTH 4.0

Connexion



← Connexion à l'App →



- 1) Outre l'enregistrement, il permet plusieurs méthodes de connexion.
- 2) Si vous oubliez votre mot de passe, veuillez cliquer pour le récupérer en saisissant le numéro de série sur la poignée de saut.

Connexion Bluetooth

- 1) Activez le Bluetooth sur votre téléphone portable.
- 2) L'icône Bluetooth commence à clignoter lorsque l'écran est lumineux.
- 3) Sur la page Gestion des appareils de l'application, recherchez et trouvez le numéro de modèle : wozuil xxx, puis cliquez dessus pour vous connecter.

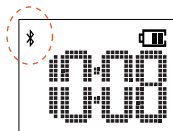

Liste de Classement

Il est pratique de vérifier le classement des sauts via l'application Wozuil.

L'utilisateur peut ouvrir l'application et synchroniser les données du jour sur le serveur, puis les données de l'exercice seront mises à jour dans la liste de classement.

Grâce aux encouragements d'amis, cela motivera l'enthousiasme de l'exercice.

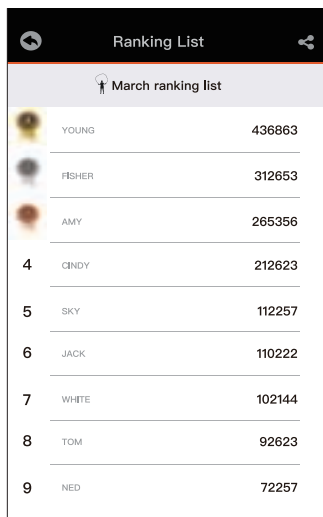

The screenshot shows a mobile application interface titled 'Ranking List'. Below the title is a subtitle 'March ranking list' with a person icon. The list contains nine entries, each with a profile picture, a name, and a score. The entries are separated by horizontal lines. The scores are: YOUNG (436863), FISHER (312653), AMY (265356), CINDY (212623), SKY (112257), JACK (110222), WHITE (102144), TOM (92623), and NED (72257).

	Name	Score
1	YOUNG	436863
2	FISHER	312653
3	AMY	265356
4	CINDY	212623
5	SKY	112257
6	JACK	110222
7	WHITE	102144
8	TOM	92623
9	NED	72257

Camarade PK

Les utilisateurs de Wozuil Corde Intelligente peuvent former un groupe de 6 personnes maximum et régler le temps d'exercice sur PK entre amis.

Grâce à PK, il peut apporter de la joie, stimuler la compétition et le potentiel, et mieux atteindre l'objectif de l'entraînement, du sport et de la forme physique.

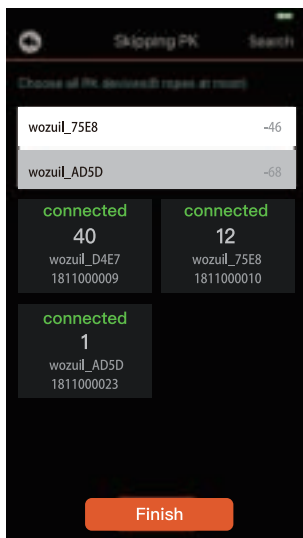

Paramètres du Produit

Nom du produit	Corde intelligente
Type de connexion	Bluetooth 4.0
Portée de synchronisation	Environ 10 mètres
Dimensions du manche	34 x 34 x 192mm
Matériau du manche	ABS, Alliage de zinc, PMMA et EVA
Réglage de la longueur	Réglable
Matériau du câble	Câble métallique revêtu de TPU
Poids	Environ 300 grammes (batteries comprises)
Affichage	LCD
Eclairage	LED RGB
Batterie	2 piles AAA
Autonomie en veille	Un ans
Type d'axe	Roulement
Enregistrement	Données quotidiennes sur les sauts à la corde au cours des 14 derniers jours
Produit inclus	Des poignées, des cordes à sauter et un manuel d'utilisation

NOTER: Les piles ne sont pas incluses dans la boîte du produit.

Meltazo®

Incredible Possibilities



<https://meltazo.com>

Merci beaucoup d'avoir acheté l'un de nos produits préférés.



"Scannez ici pour voir comment installer et utiliser notre Corde Intelligente"

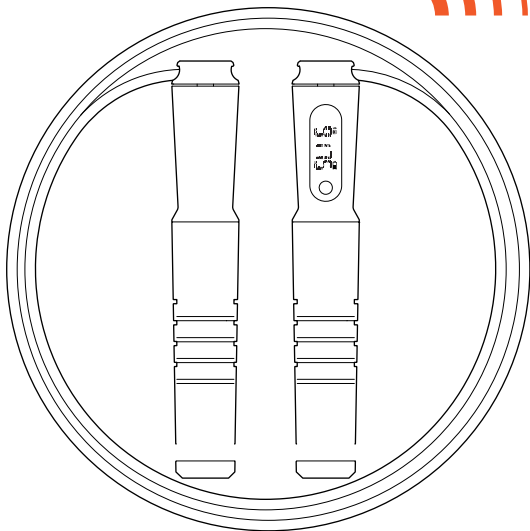

MELTAZO Intelligentes Springseil
BENUTZERHANDBUCH (DEUTSCHE)





Bluetooth 4.0



Anzahl der Sprünge



Kalorien



Durchschnittsgeschwindigkeit



Zeit



Fett Verbrannt



Zeiteinstellung



Ziel



Rangierend



Überspringen PK

Batterieinstallation

Funktionsgriff

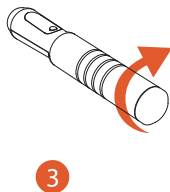
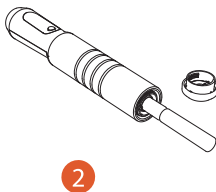
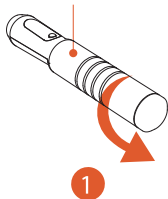

- 1) Öffnen Sie den Batteriedeckel des Funktionsgriffs,
- 2) Legen Sie 2 Stück AAA-Batterien ein, und
- 3) Schließen Sie die Batterieabdeckung.

※ Wenn das rote LED-Licht leuchtet, bedeutet dies, dass der Akku noch etwa 3 % Energie hat. Bitte ersetzen Sie die Batterie.

LCD-Display & Rollengriff

Anzahl der Sprünge des Tages Geschwindigkeit des letzten Trainings/Minuten

Bluetooth-Verbindungsstatus

- Bluetooth ist Auf.
- Bluetooth ist Verbunden.

Kalorien Ziel
Timer Batterieleistung

Datum oder Uhrzeit
(24-Stunden-System)

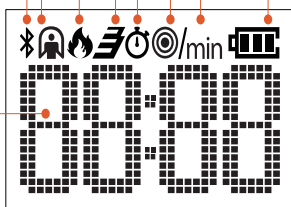

- Bluetooth ist Auf.
- Bluetooth ist Verbunden.
- Firmware wird Aufwertung.
- Leiser Stromalarm

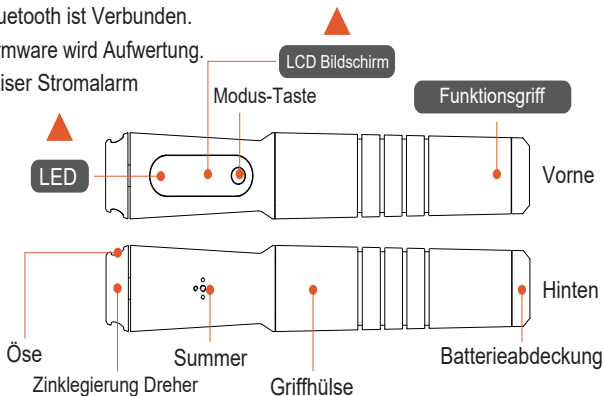

LCD-Anzeige Fluss

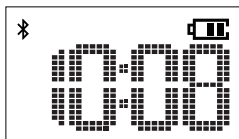

Uhrzeit

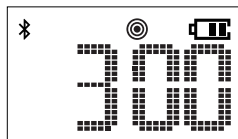

Zielkreisnummer

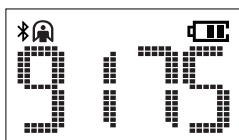

Anzahl der Sprünge

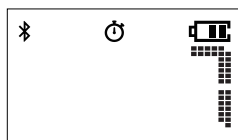

Zeiteinstellungen (Minuten)

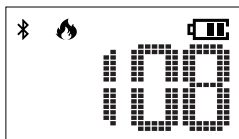

Kalorien

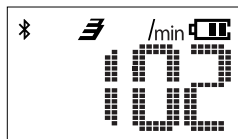

Geschwindigkeit /Minute

Manuelle Einstellung des Trainings Ziels

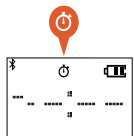
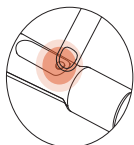

1) Einstellen der Trainingszeit als Ziel:

Tippen Sie auf den Modellschlüssel und das Symbol --:-- erscheint und dann auf den Model Key, Symbol --:-- beginnt zu blinken. Tippen Sie auf den Schlüssel, um die Übungszeit als Ziel einzustellen (UOM: min). Lange Drücken, um den Einstellmodus zu verlassen. Es zeigt 3-2-1 mit drei kurzen Sounds, dann ein langer Sound als Erinnerung an das Starten des Spielens, und es wird automatisch abzählen. Bei der Erfüllung des Ziels wird das Intelligente Springseil drei kurze Sounds als Erinnerung an die Fertigstellung des Ziels spielen. Das LCD-Display zeigt automatisch die Anzahl der Skips der Übung an.

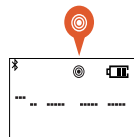

2) Einstellen der Springnummer als Ziel:

Tippen Sie auf den Modellschlüssel und das Symbol ---- erscheint und dann lange drücken Sie den Modellschlüssel, Symbol beginnt zu blinken. Tippen Sie auf den Schlüssel, um die Übung überspringt die Zahl als Ziel (Mindestens 100, maximal 2000). Lange Drücken, um den Einstellmodus zu verlassen. Es zeigt 3-2-1 mit drei kurzen Sounds, dann ein langer Sound als Erinnerung an das Starten des Spielens, und es wird automatisch abzählen. Bei der Erfüllung des Ziels wird das Intelligente Springseil drei kurze Sounds als Erinnerung an die Fertigstellung des Ziels spielen. Das LCD-Display zeigt automatisch die Übungszeit an.



Wozuil



Scannen Sie den QR-Code auf dem Geschenkbox und besuchen Sie die offizielle Website (www.wozuil.com), klicken Sie auf die Download-Schaltfläche für App-Download, oder suchen Sie im APP-Store für App-Download im "wozuil". Installieren Sie die App und starten Sie des Seils überspringen für Fitness.



www.wozuil.com

iOS

Systemvoraussetzung:
iOS7 und höher

Android

Systemvoraussetzung:
Android 4.3 und höher

BLUETOOTH 4.0

Anmeldung



← Starten die App



- 1) Neben der Registrierung ermöglicht es mehrere Methoden, sich anzumelden.
- 2) Wenn Sie Ihr Passwort vergessen haben, klicken Sie bitte, um es abzurufen, indem Sie die Seriennummer auf dem Springgriff eingeben.

Bluetooth-Verbindung

- 1) Schalten Sie das Bluetooth auf Ihrem Handy ein.
- 2) Das Bluetooth-Symbol beginnt zu blinken, wenn der Bildschirm hell ist.
- 3) Auf der App-Geräte-Management-Seite in der App, suchen und finden Sie Modell Nr. : wozuil xxx, dann klicken klicken Sie dann darauf, um eine Verbindung herzustellen.

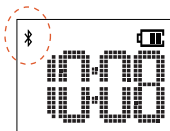

Rangliste

Es ist bequem, die Sprungrangliste über die Wozuil-App zu überprüfen.

Der Benutzer kann die App öffnen und die Daten des Tages auf den Server synchronisieren, dann werden die Übungsdaten auf die Rangliste aktualisiert.

Durch die Ermutigung der Freunde wird es die Begeisterung der Bewegung motivieren.

Ranking List		
March ranking list		
	YOUNG	436863
	FISHER	312653
	AMY	265356
4	CINDY	212623
5	SKY	112257
6	JACK	110222
7	WHITE	102144
8	TOM	92623
9	NED	72257

Kamerad PK

Die Benutzer des Wozuil Intelligentes Seil können eine Gruppe von maximal 6 Personen bilden und die Trainingszeit unter Freunden auf PK stellen.

Durch PK kann es Freude bereiten, den Wettbewerb und das Potenzial stimulieren und den Zweck der Übung, des Sports und der Fitness besser erreichen.

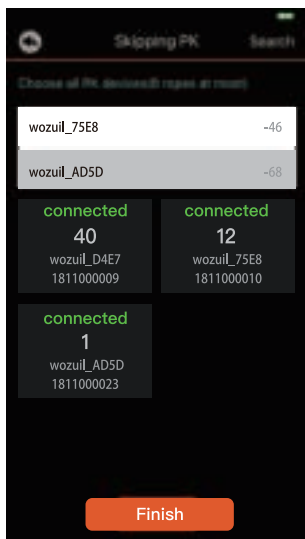

Produktparameter

Produktname	Intelligentes Springseil
Anschlusstyp	Bluetooth 4.0
Synchronisation Bereich	Ungefähr 10 Meter
Griffgröße	34 x 34 x 192mm
Griffmaterial	ABS, Zinklegierung, PMMA & EVA
Längebereinigung	Einstellbare
Seilmaterial	TPU-beschichtetes Drahtseil
Gewicht	Ungefähr 300 Gramm (einschließlich Batterien)
Anzeige	Flüssigkristallanzeige
Beleuchtung	RGB-LED
Batterie	2 Stück AAA-Batterien
Bereitschaftszeit	Ein Jahr
Achsentyp	Tragend
Aufzeichnung	Tägliche Springen von Seildaten in den letzten 14 Tagen
Produkt enthalten	Griffe, Springseile und Bedienungsanleitung

HINWEIS: Batterien sind nicht im Produktbox enthalten.

Meltazo®

Incredible Possibilities



<https://meltazo.com>

Vielen Dank für den Kauf eines unserer Lieblingsprodukte.



"Scannen Sie hier, um zu beobachten, wie Sie unser Intelligentes Springseil installieren und verwenden"