



To be the Chief Evangelist

Ender-5 Pro Printer Guide Book

To make Top-quality 3D printer



- ◆ This guide book is for standard Ender-5 Pro.
- ◆ Please plug the power cord into a three-hole power jack.
- ◆ Detailed instructions for use are available in the TF card.

Contents

1.Introduction.....	1	6.Loading Filament.....	11
2.General List.....	2	7.Bed Levelling.....	12
3.Assembly Step.....	3	8.Software Installation.....	13
4.Cable Connection.....	8	9.Preparing to Print.....	14
5.Screen Information.....	10	10.Trouble shooting.....	15

Preface

Dear consumers,

Thank you for choosing our products. For the best experience, please read the instructions before operating the Printer. Our 3D team will always be ready to give you the best service. Please contact us via the phone number or e-mail address provided at the end when you encounter any problem with the Printer.

For a better experience in using our product, you may learn how to use the Printer in the following ways:

1. View the accompanied instructions and videos in the TF card.
2. Visit our official website www.creality.com You will find relevant software/hardware information, contact details and operation and maintenance instructions on the website.

Notes

1. Do not use the printer any way other than described herein in order to avoid personal injury or property damage.
2. Do not place the printer near any heat source or flammable or explosive objects. We suggest placing it in a well-ventilated, low-dust environment.
3. Do not expose the printer to violent vibration or any unstable environment, as this may cause poor print quality.
4. Before using experimental or exotic filaments, we suggest using standard filaments such as ABS or PLA to calibrate and test the machine.
5. Do not use any other power cable except the one supplied. Always use a grounded three-prong power outlet.
6. Do not touch the nozzle or printing surface during operation as they may be hot. Keep hands away from machine while in use to avoid burns or personal injury.
7. Do not wear gloves or loose clothing when operating the printer. Such cloths may become tangled in the printers moving parts leading to burns, possible bodily injury, or printer damage.
8. When cleaning debris from the printer hotend, always use the provided tools. Do not touch the nozzle directly when heated. This can cause personal injury.
9. Clean the printer frequently. Always turn the power off when cleaning, and wipe with a dry cloth to remove dust, adhered printing plastics or any other material off the frame, guide rails, or wheels . Use glass cleaner or isopropyl alcohol to clean the print surface before every print for consistent results.
10. Children under 10 years of age should not use the printer without supervision.

A、 Introduction

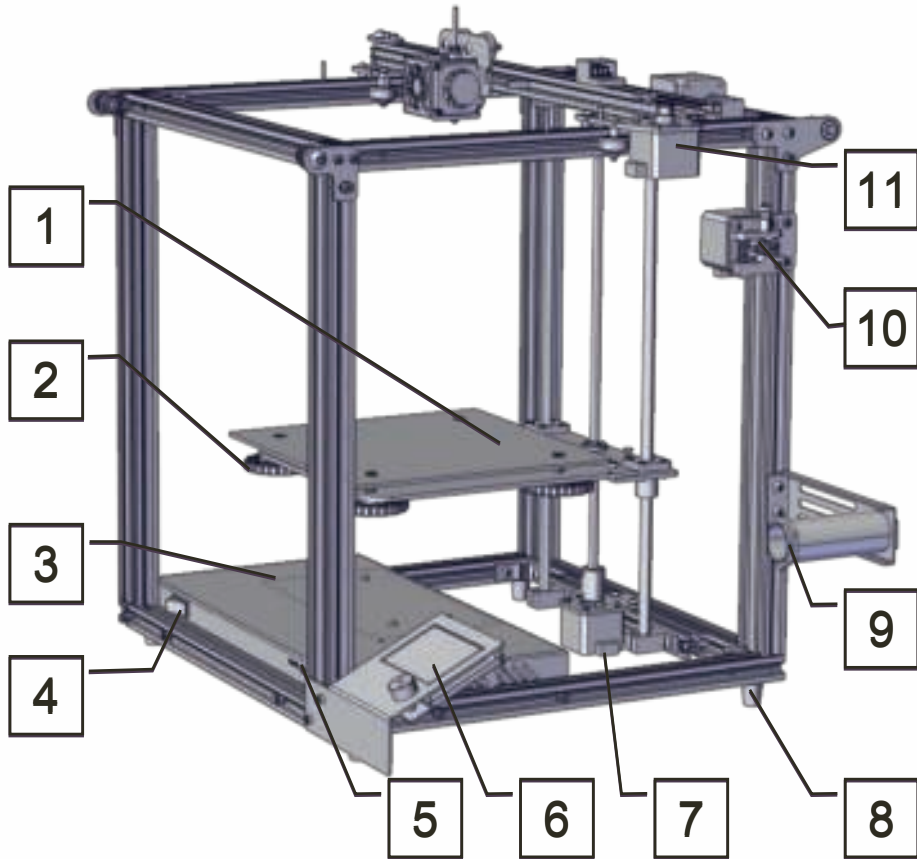

- 1.Hot Bed
- 2.Levelling screw
- 3.Power supply
- 4.Switch
- 5.SD Slot and USB Port
- 6.Display
- 7.Z Stepper
- 8.Foot pad

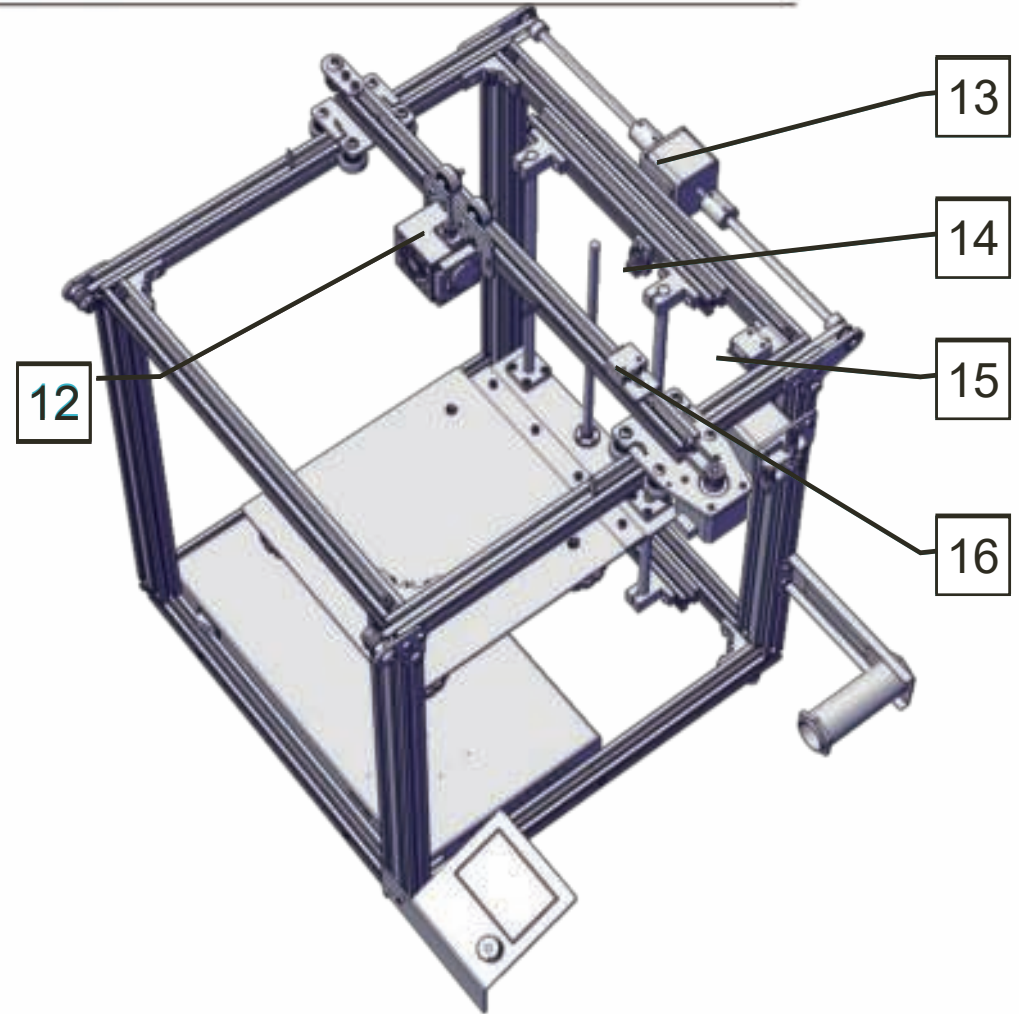

- 9.Spool Holder
- 10.Extrusion mechanism
- 11.X Stepper
- 12.Nozzle Assembly
- 13.Y Stepper
- 14.Z Limit Switch
- 15.Y Limit Switch
- 16.X Limit Switch

B、General List

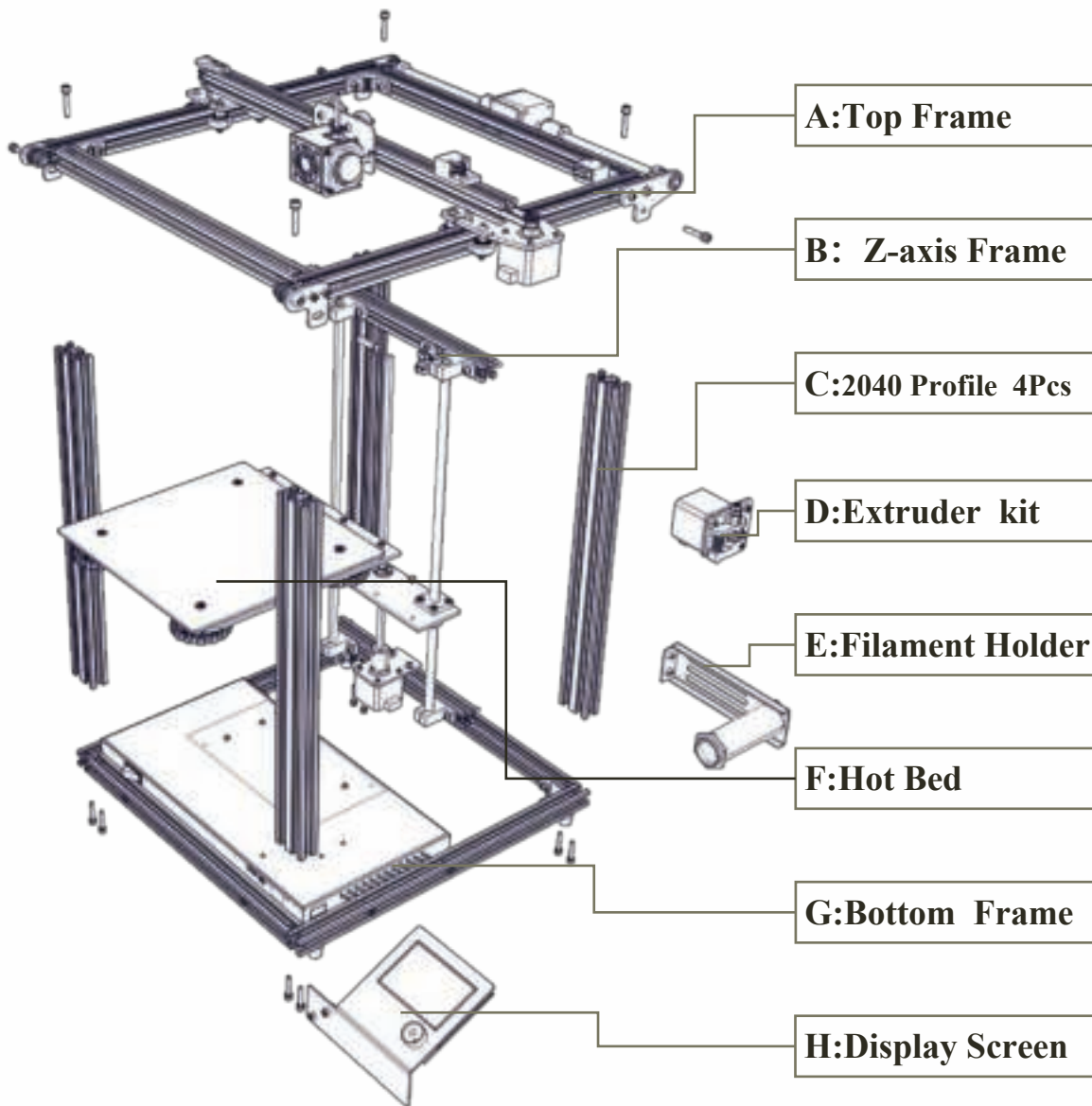

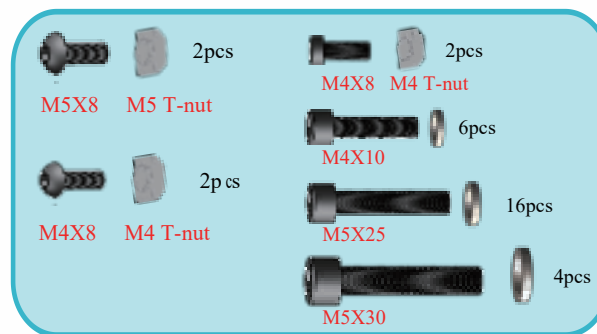

Tool List

No.	Image	Name	Qty
1		Wrench & Screw driver	1set
2		TF Card & Reader	1set
3		Spatula	1
4		Pliers	1
5		0.4mm Nozzle Cleaner	1
6		Power Cable	1
7		Filament(200)g	1
8		Spare Parts	1set

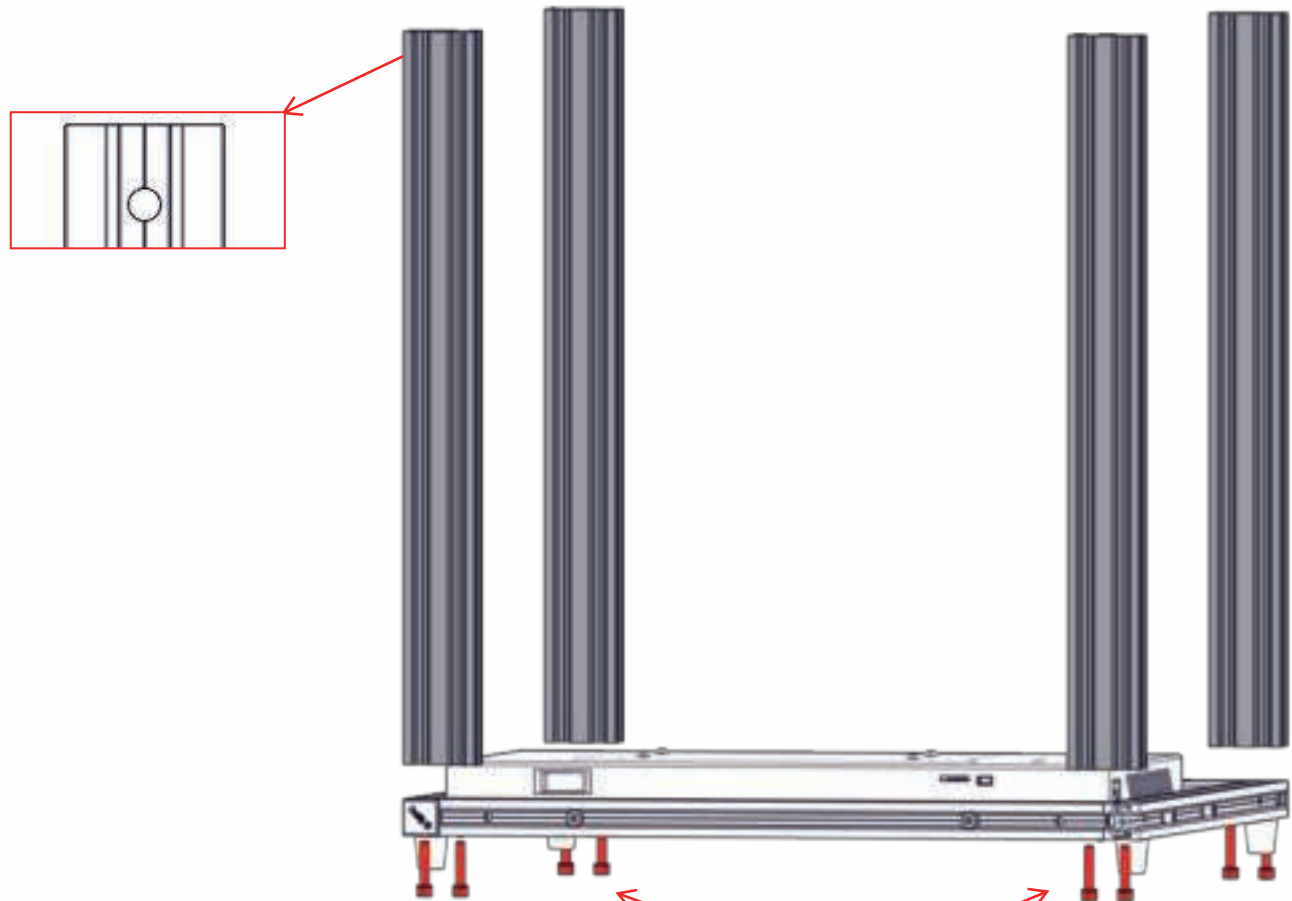

C、 Assembly Step



 Place the profile hole of the side upon, install the profile, but not mess with the direction.



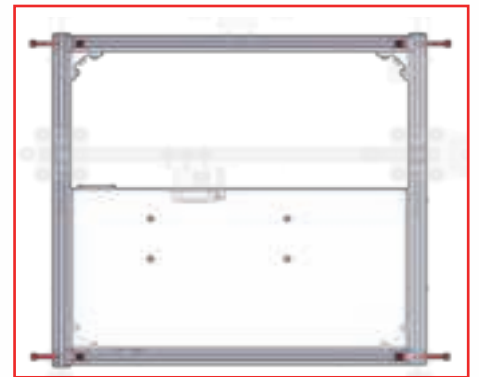
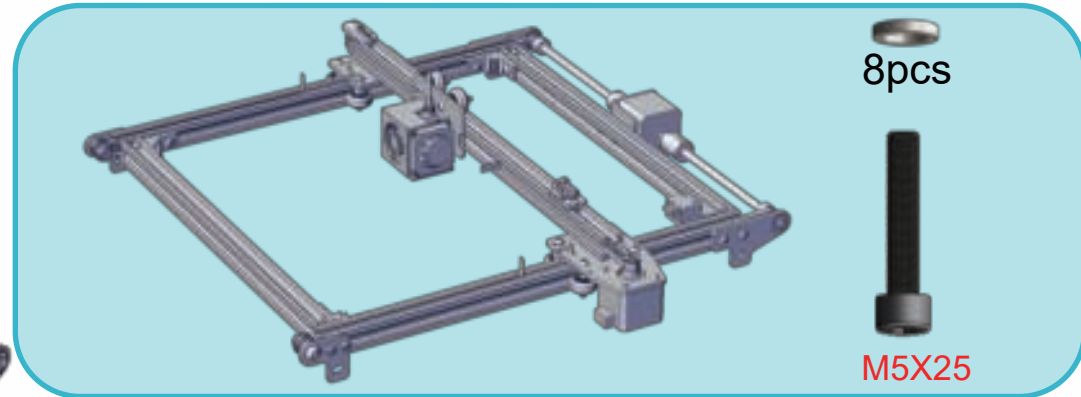
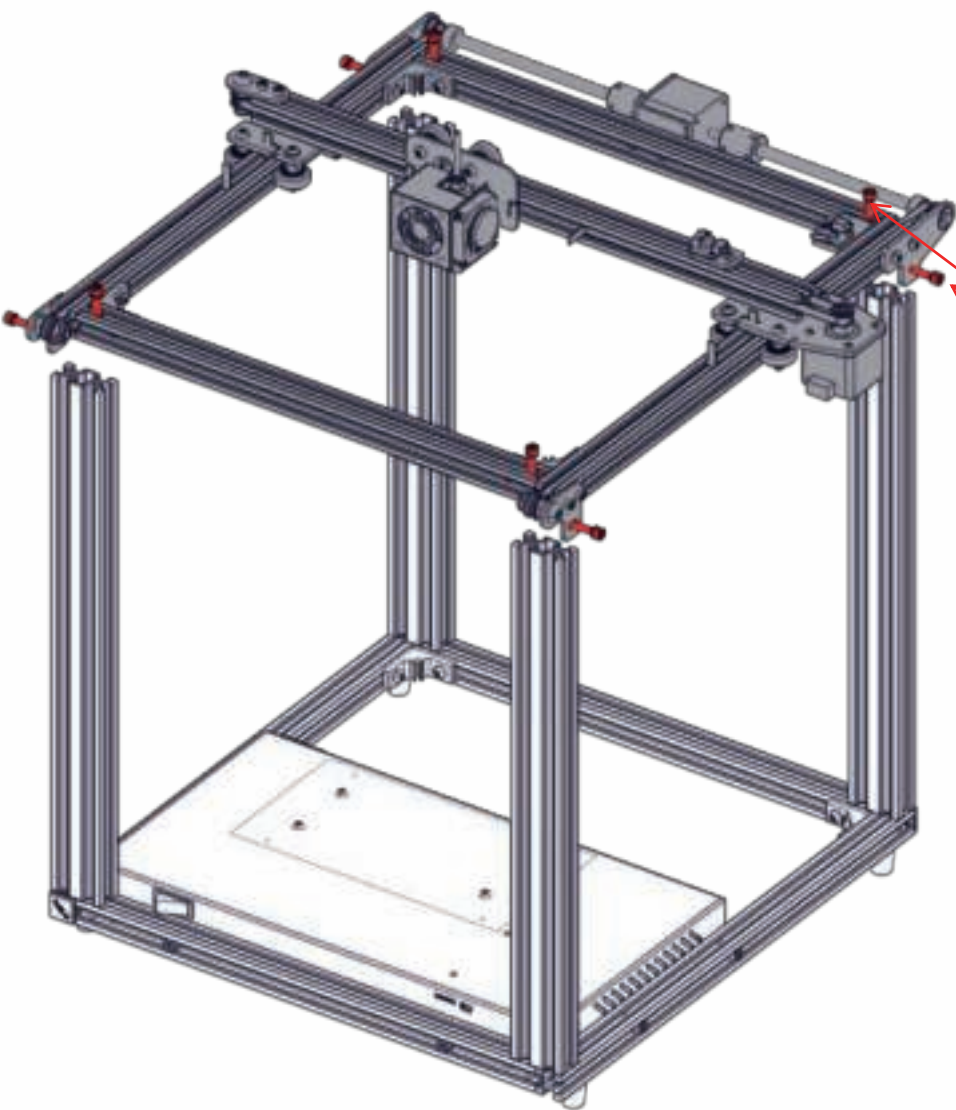

Note: Tighten the four screws on the top, then tight the side screws.

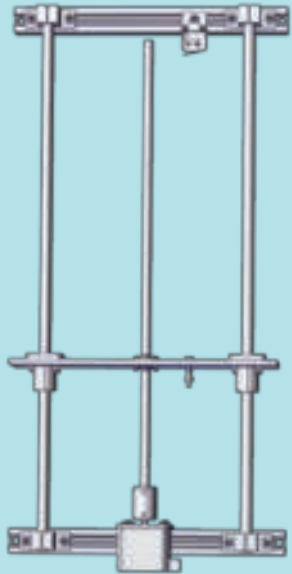

Z-axis Frame

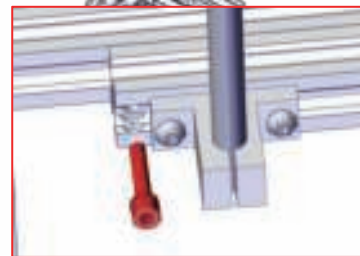

i Note: Align the bottom profile ,then tighten the screws.

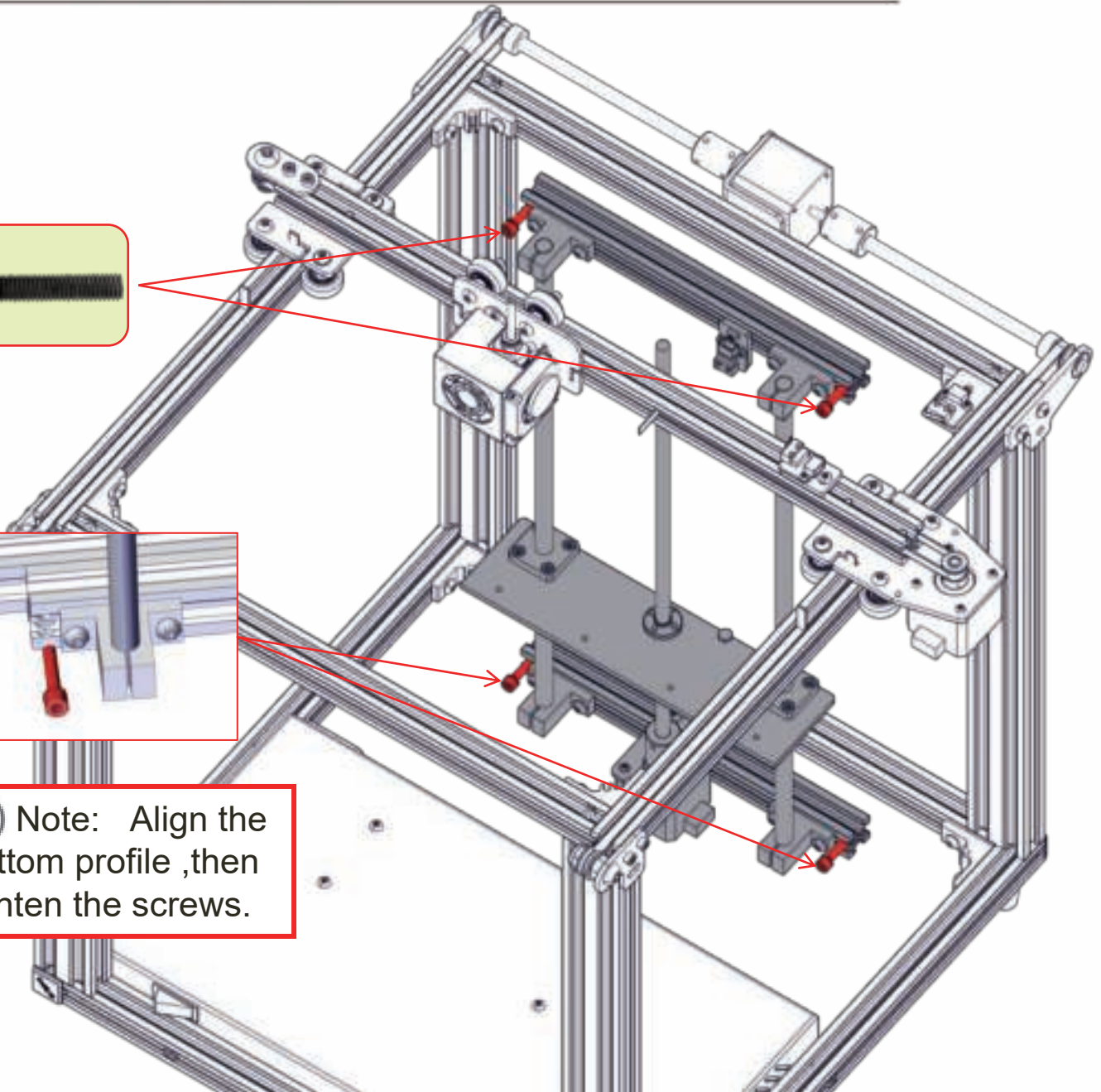

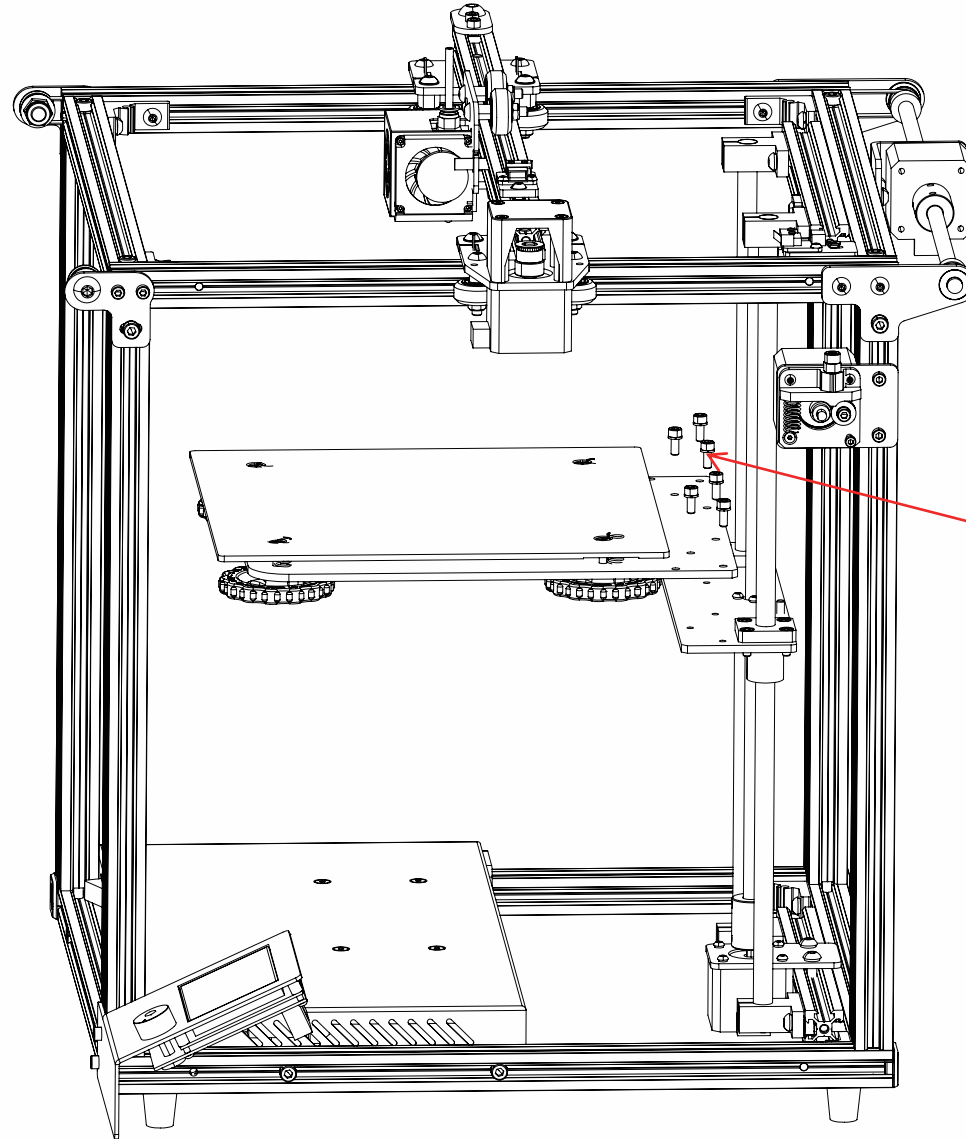

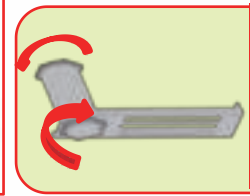
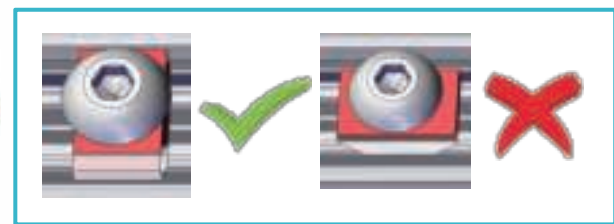
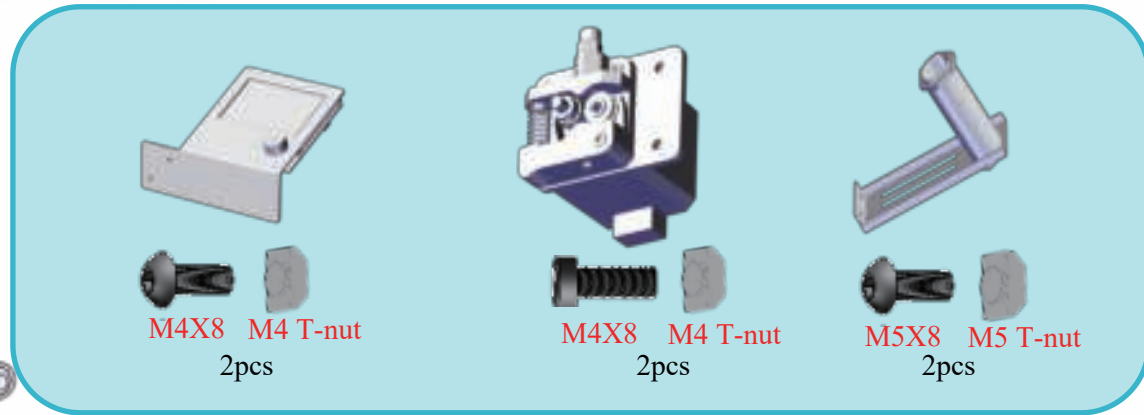
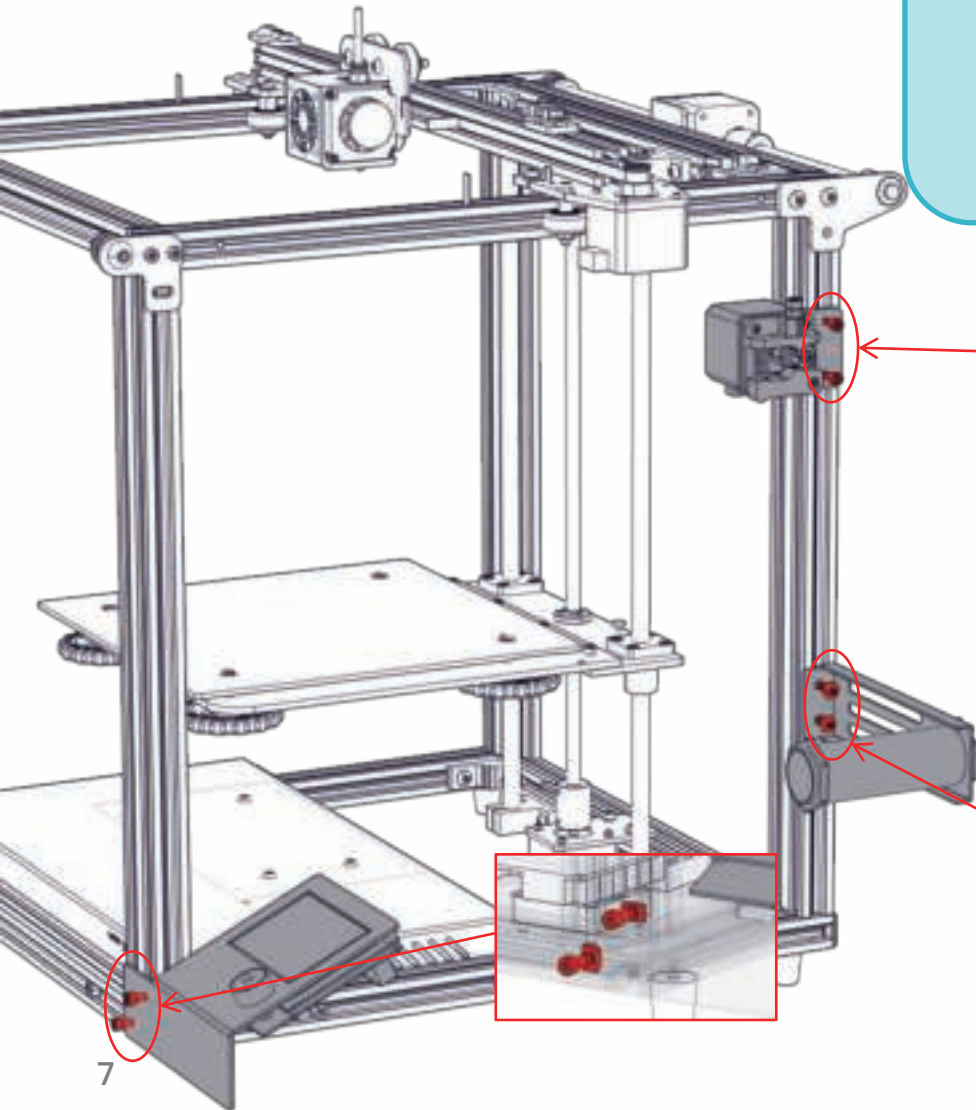

D、 Cable Connection

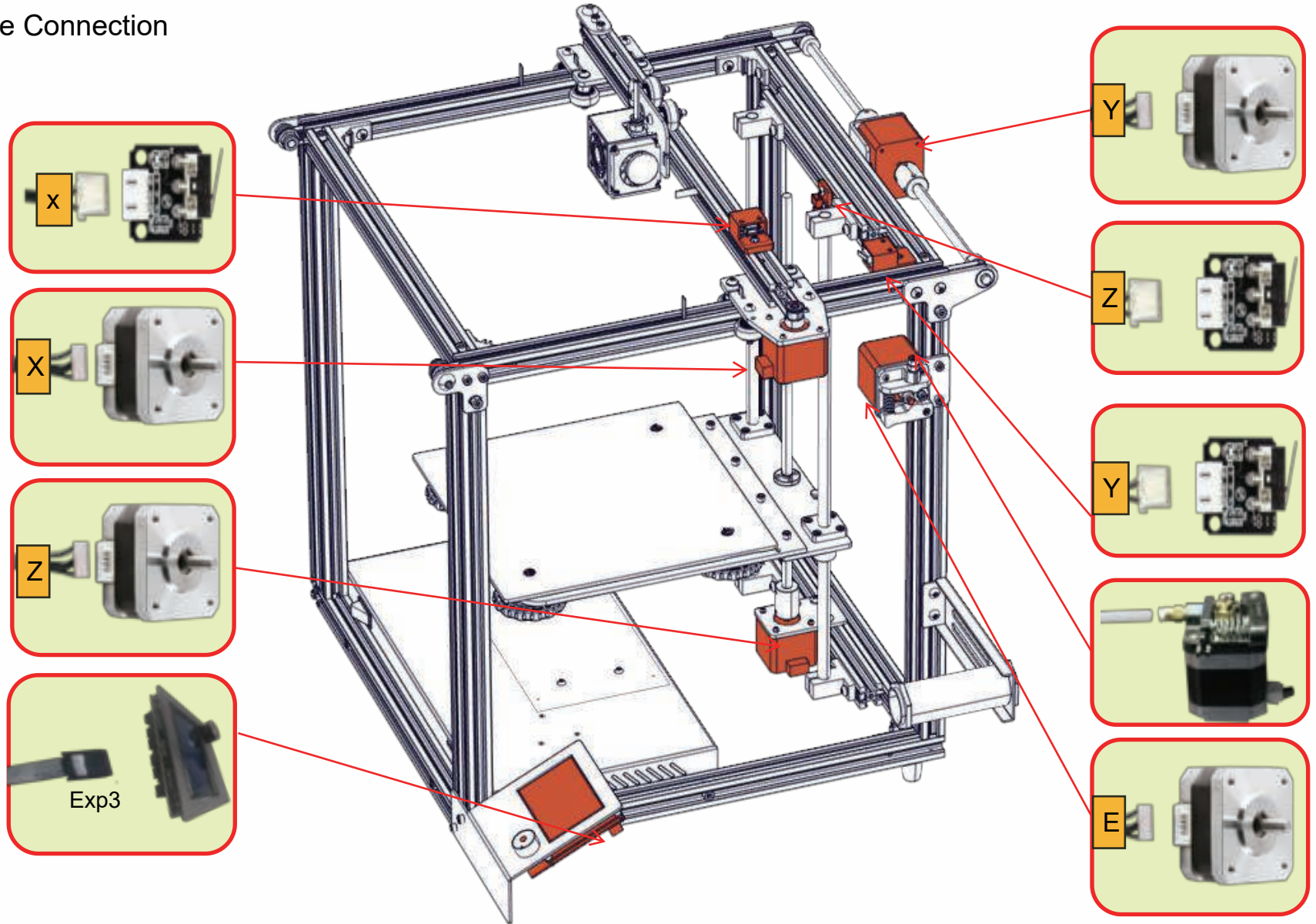

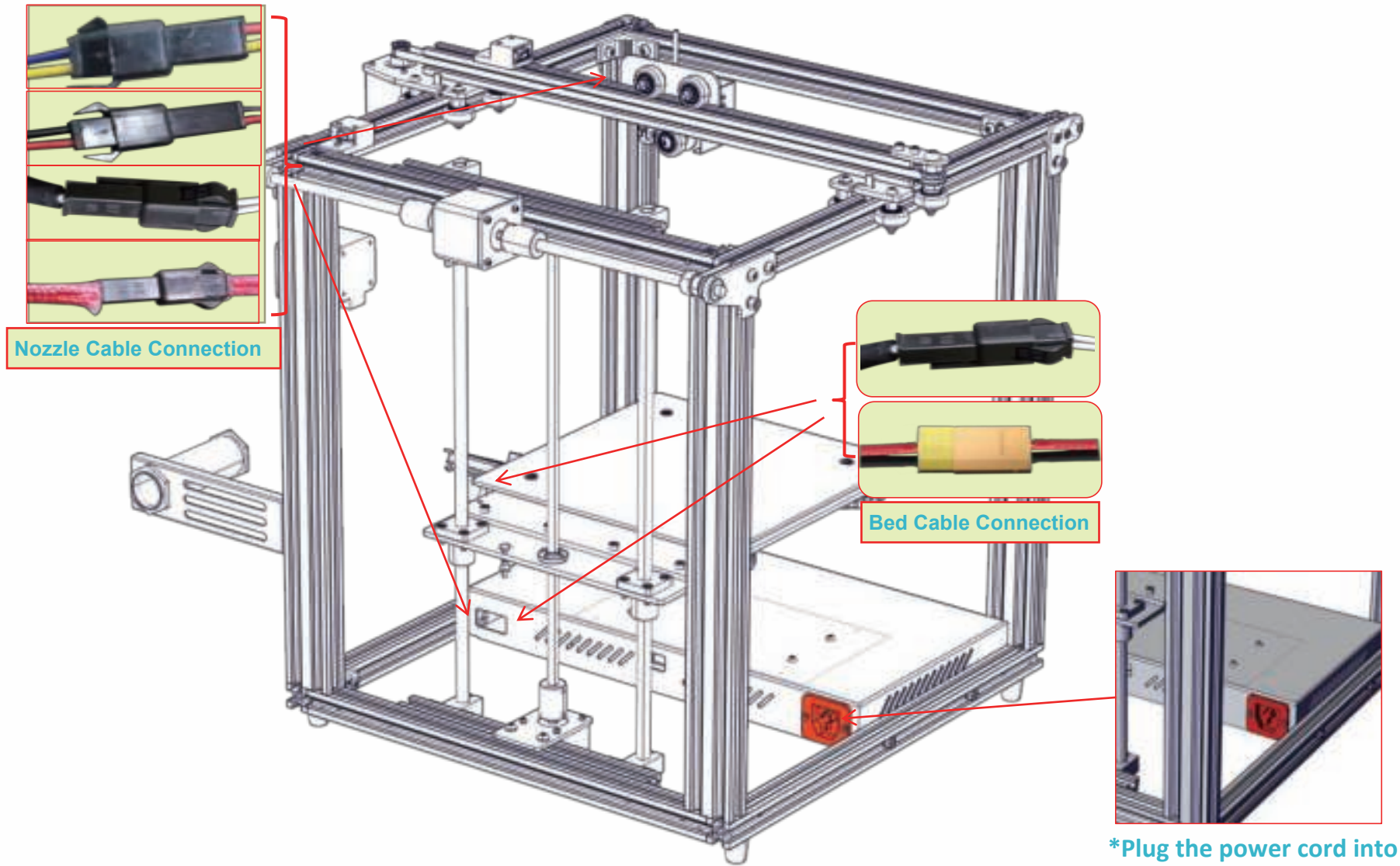

E、Screen Information

Information Displayed

The diagram shows the printer's LCD screen with various information elements highlighted by callouts:

- Print Speed**: Indicated by a gear icon and a percentage value (100%).
- Model**: Indicated by the text 'Ender-5 Pro'.
- Set Temperature of the Nozzle**: Indicated by '0°' and a target icon.
- Current Temperature of the Nozzle**: Indicated by '19°'.
- Set Temperature of the Hot Bed**: Indicated by '0°' and a target icon.
- Current Temperature of the Hot Bed**: Indicated by '22°'.
- Part Cooling Fan Speed**: Indicated by a fan icon and a percentage value (0%).
- Current Location of the nozzle**: Indicated by 'X 0 Y 0 Z 0'.
- Print Time**: Indicated by '00:00'.
- Print Progress**: Indicated by a progress bar.
- Prompt Message**: Indicated by 'Ender-5 Pro ready.'

Navigation instructions:

- Push: OK/Enter Sub Menu**
- Turn: Change Option/Value**

Screen Options		
Menu	Sub Menu	Explanation
↑ Info Screen ↑	↑ main ↑	Return
Prepare →	Disable Steppers	Moving X Y Z axis by your hands
	Auto Home	return to the origin
	Preheat PLA	
	Preheat ABS	
	Cooldown	Close and cooldown the nozzle
Control →	Move Axis →	Moving X Y Z axis or Extruder by given value.
	Temperature →	Heat the nozzle and the bed or change fan speed by given value
	Restore Failsafe	Restore factory setting
No card /Print from SD	Select the printing model	
Init. SD-Card /Change SD-Card		
Printing		
Tune →	Speed	Change Printing Speed by given value
	Nozzle	Change the temperature by given value
	Bed	Change the temperature by given value
	Fan Speed	Change Fan Speed by given value
	Flow	Change filament flow by given value
Pause Print		
Stop Print		

F、 Loading Filament

1. Preheat

Method 1

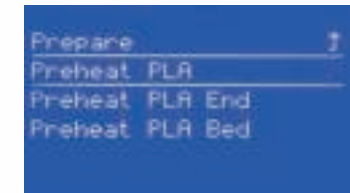
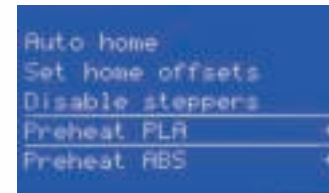
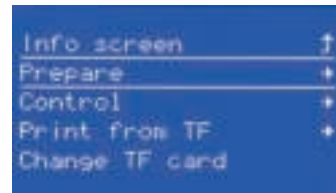

Method 2

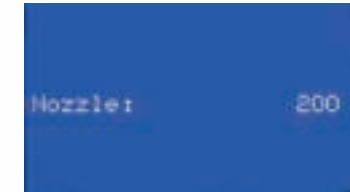
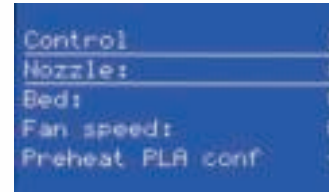
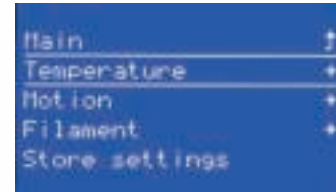
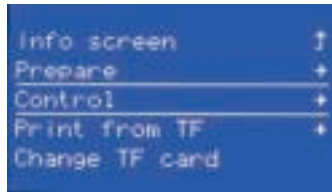

2. Feeding

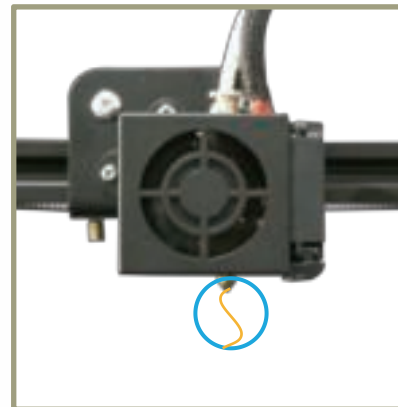

Press and hold the extruder lever then insert 1.75mm filament through the small hole of the extruder. Continue feeding until you see filament come out the nozzle.

Tip: How to Replace the Filament?

- 1、 Cutting filament near the Extruder and slowly feed new filament until they are fed into the new filament.
- 2、 Preheating the nozzle and withdraw the filament quickly and feed the new filament.

G、 Bed Levelling

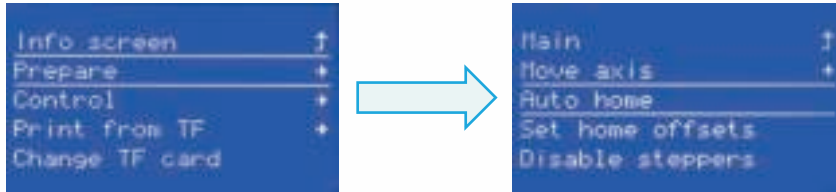

1. Prepare → Auto Home. Wait for the nozzle to move to the left/front of the platform.

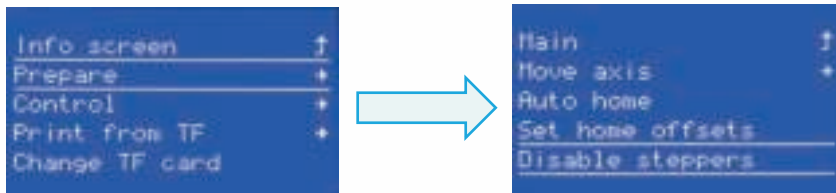

2. Prepare → Disable Steppers (Close stepper drive, release motor)

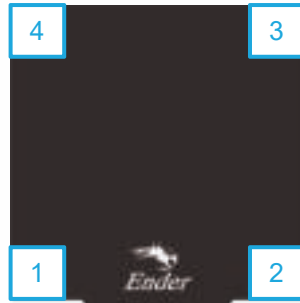
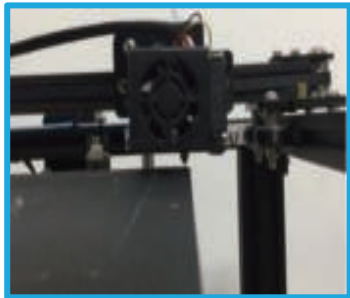

3. Move the nozzle the front/left leveling screw and adjust the platform height by turning the knob underneath. Use a piece of A4 paper (standard printer paper) to assist with the adjustment, making sure that the nozzle lightly scratches the paper.

4. Complete the adjustment of the screw on all 4 corners.
5. Repeat above steps 1-2 times if necessary.

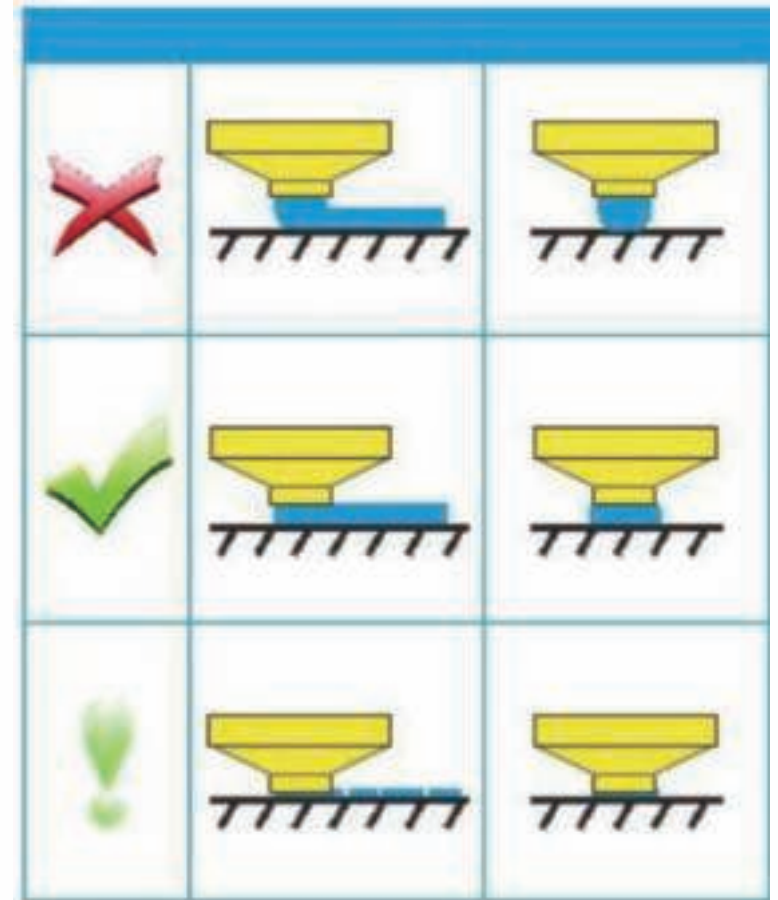

H、 Software Installation



Creality
Slicer_1.2.3

1. Double click to install the software.



Creality Slicer

2、 Double click to open the software.

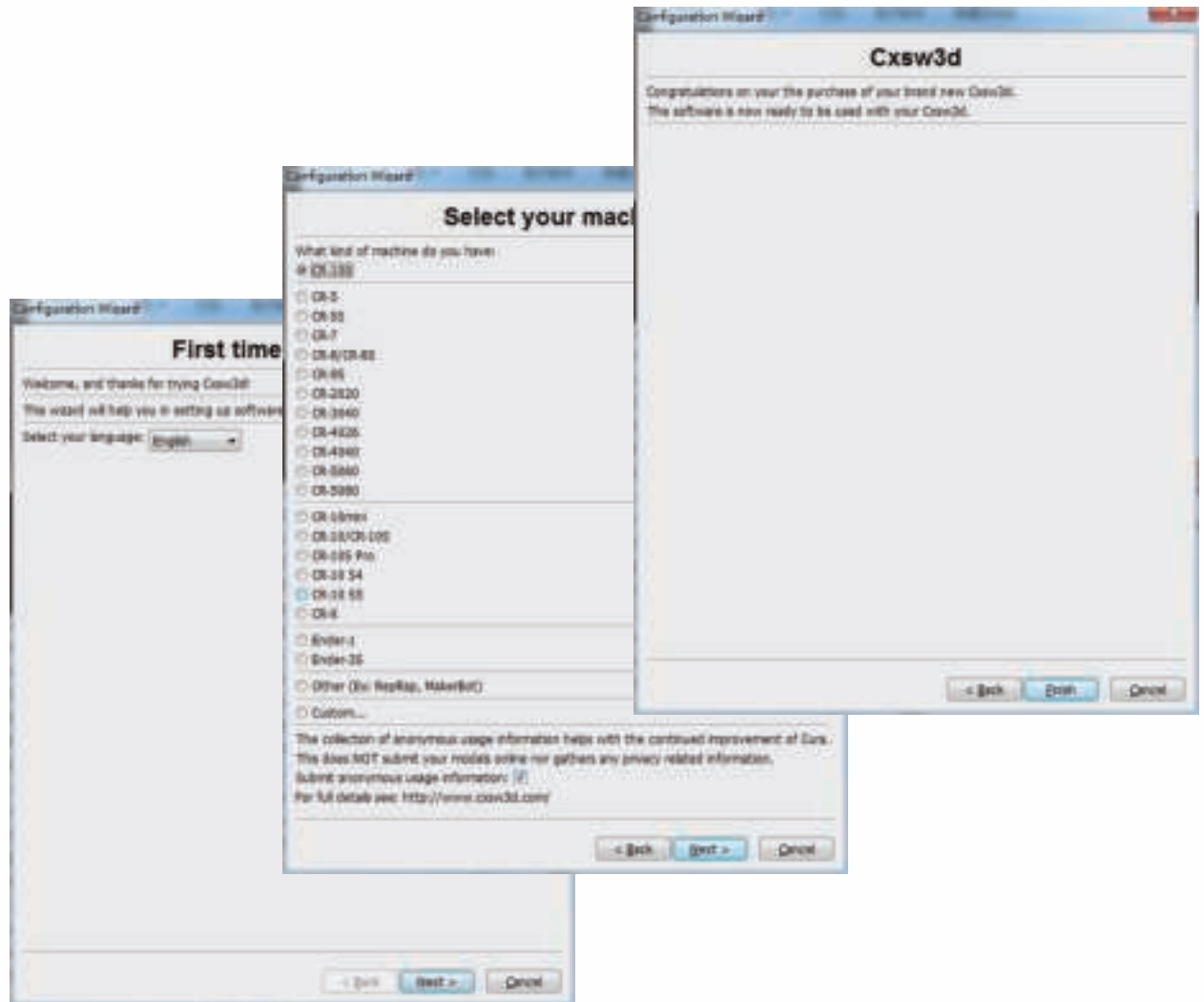

3. Select language→Next→Select your machine→Next→Finish.

I、Preparing to Print

1.Slicing

Insert TF card into computer with Reader.



Open the software→Load→Select the file→Wait for slicing to finish ,and save the gcode file to TF card.

2.Printing

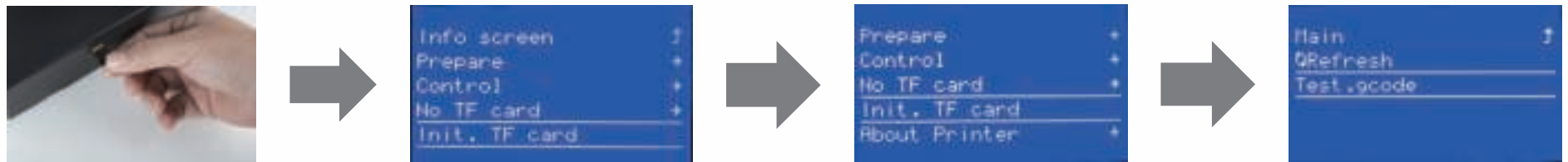

Insert the TF card→Select Print from TF →Select the file.

J、 Trouble shooting

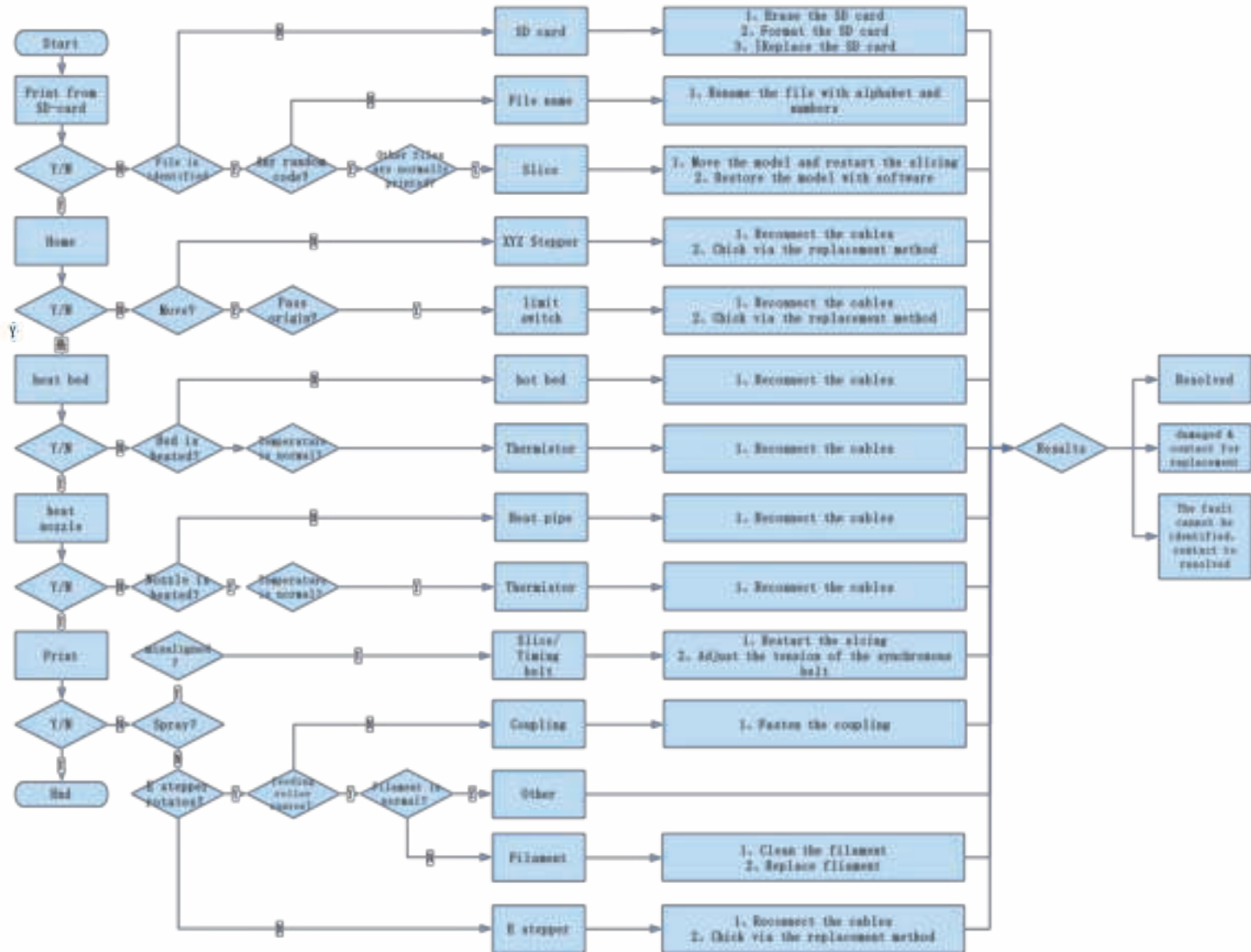

After– Sales Service

Service

1, The printer can be returned within seven days, 15 days replacement, one year warranty, lifetime maintenance.

Replacement requirement

1. The appearance of the product is intact, without damage, scratches, smudges, cracks, deformation, etc.;
2. Machine parts, tools and others are complete;
3. Provide a complete and valid purchase invoice and warranty, product number should be the same.

Warranty coverage

1. The following accessories are not included in the warranty coverage if they are not damaged by transportation: platform sticker; platform forming plate; acrylic cover; card reader and TF card; platform glass; USB cable; filament; rack and tools,etc.
2. Profile: Before we deliver the goods, we will do the machine test, so maybe there will be light scratch, or due to long–distance transportation, which scratch the profile a little bit. in the premise of not affecting the normal use, in principle, not within the scope of warranty;
3. Nozzle assembly (nozzle, heating block, throat pipe,heat sink, Teflon tube, etc.) warranty period is 3 months, if it is damage after the warranty expires, you need to purchase another one;
4. Motherboard, LCD display, power supply, hot bed,warranty period is 12 months, if there are quality problems, you can get free maintenance; over the warranty period, can be sent back to the original factory maintenance, the users need to bear the return shipping and maintenance costs;
5. Not included in warranty coverage:
 - (1) It is not possible to provide an effective after–sales service card or serial number;
 - (2) The whole machine and components exceed the warranty period;

- (3) Equipment failure or damage caused by unauthorized modification of the equipment (private modification includes: 1. modification of the nozzle assembly; 2. modification of the machine structure; 3. use of third–party components; 4. use of third–party firmware procedures or change the original Factory firmware program, etc.);
- (4) Equipment failure or damage due to incorrect installation and use;
- (5) Equipment failure or damage caused by the use of the equipment in a working environment not specified by the product;
- (6) Equipment failure or damage due improper use (beyond workload, etc.) or maintenance (moisture, etc.);
- (7) Equipment failure or damage due to the use of other branded components or low quality consumables.

Statement:

For better highlighting the function and effectiveness of 3d printer and promoting the development of global market economic, strengthening the user self–discipline of 3d industry and establishing a good image of 3d printing, since Creality 3d printer have passed all kinds of authorized product certificates and quality management system.hereby we declare that it is strictly forbidden to use our printer to print any products or equipment that are in violation of the specific country and regions legislation.



SHENZHEN CREALITY 3D TECHNOLOGY CO.,LTD.

11F & Room 1201,Block 3,JinChengYuan,Tongsheng Community,
Dalang,Longhua District,Shenzhen,China,518109

Official Website: www.creality.com

Tel: +86 755-8523 4565

E-mail: info@creality.com cs@creality.com

