

PERI

7629401331



User manual
Bedienungsanleitung
Mode d'emploi
Handleiding
Manuale
Manual del usuario
Használati utasítás
Instrukcja obsługi



LUTEC

Incl.

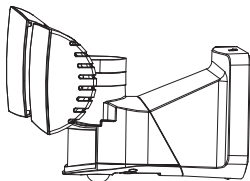

x 2



x 2

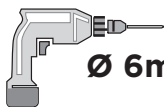

Ø 6mm

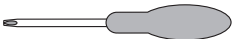

Installation

Installation/Installación/Instalación/Installazione
Installatie/Instalacja/Telepítés

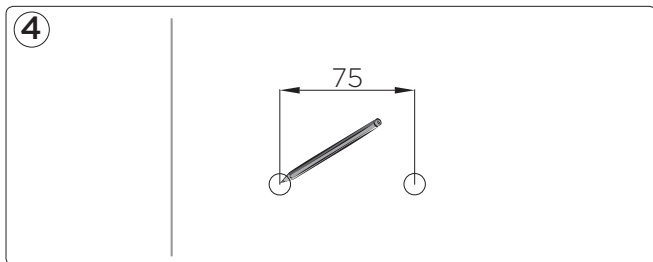
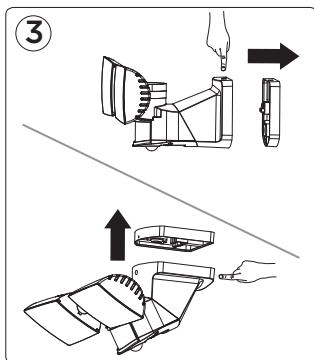
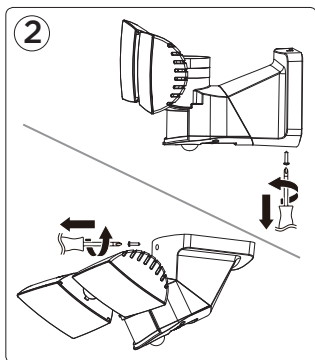
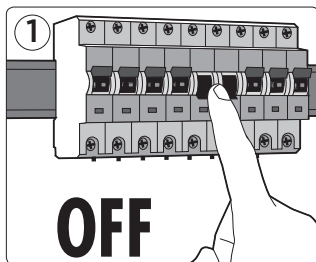

5

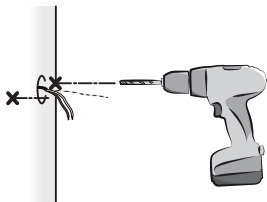

6

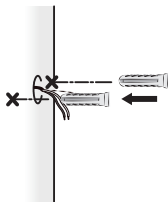

7

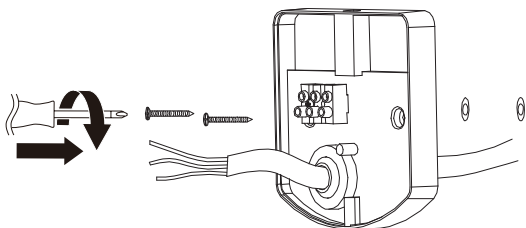

8

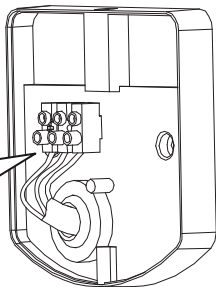
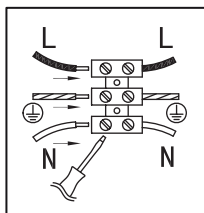

9

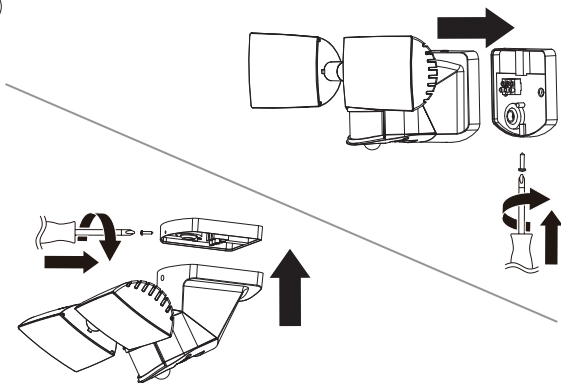

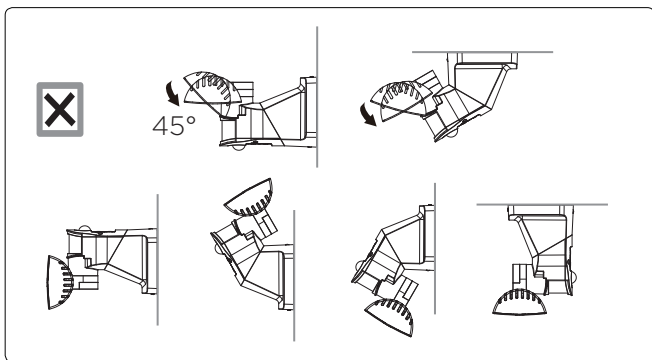
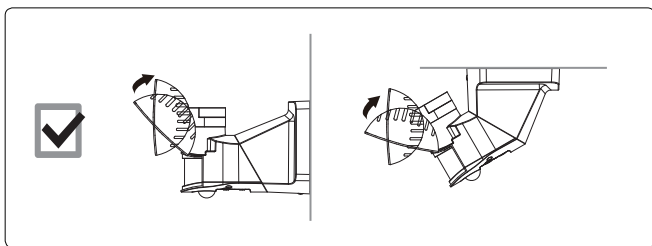
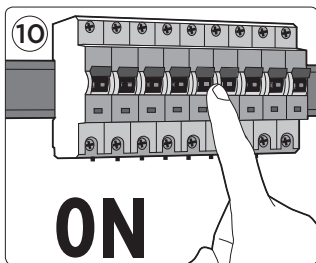

Function

Funktion/Fonction/Función/Funzione
Funcție/Funkcja/Funkció

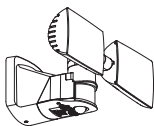

At dusk, the motion sensor becomes active.

Any movement within the detection reach will switch-on the light. The light stays on for 1-3-10 min. At dawn, the motion sensor will deactivate.

In der Dämmerung wird der Bewegungssensor aktiv.

Jede Bewegung innerhalb der Erfassungsreichweite schaltet das Licht ein.

Das Licht bleibt für 1-3-10 Minuten an. Im Morgengrauen wird der Bewegungssensor deaktiviert.

Au crépuscule, le détecteur de mouvement devient actif.

Tout mouvement dans la portée de détection allumera la lumière. La lumière reste allumée pendant 1-3-10 min. À l'aube, le détecteur de mouvement se désactivera.

Al anochecer, el sensor de movimiento se activa.

Cualquier movimiento dentro del alcance de detección encenderá la luz. La luz permanece encendida durante 1-3-10 min. Al amanecer, el sensor de movimiento se desactivará.

Al tramonto, il sensore di movimento diventa attivo.

Qualsiasi movimento all'interno della portata di rilevamento accenderà la luce.

La luce rimane accesa per 1-3-10 minuti. All'alba, il sensore di movimento si disattiverà.

In de schemering wordt de bewegingssensor actief.

Elke beweging binnen het detectiebereik zal het licht inschakelen. Het licht blijft 1-3-10 minuten branden. Bij zonsopgang wordt de bewegingsopnemer gedeactiveerd.

O zmierzchu czujnik ruchu staje się aktywny.

Każdy ruch w zasięgu wykrywania spowoduje włączenie światła. Światło pozostaje włączone przez 1-3-10 min. O świcie czujnik ruchu wyłączy się.

Alkonyatkor a mozgásérzékelő aktívá válik.

Bármely mozgás a detektálási határon belül bekapcsolja a fényt. A fény 1-3-10 percig marad. Hajnalban a mozgásérzékelő kikapcsol.

DISTANCE setting

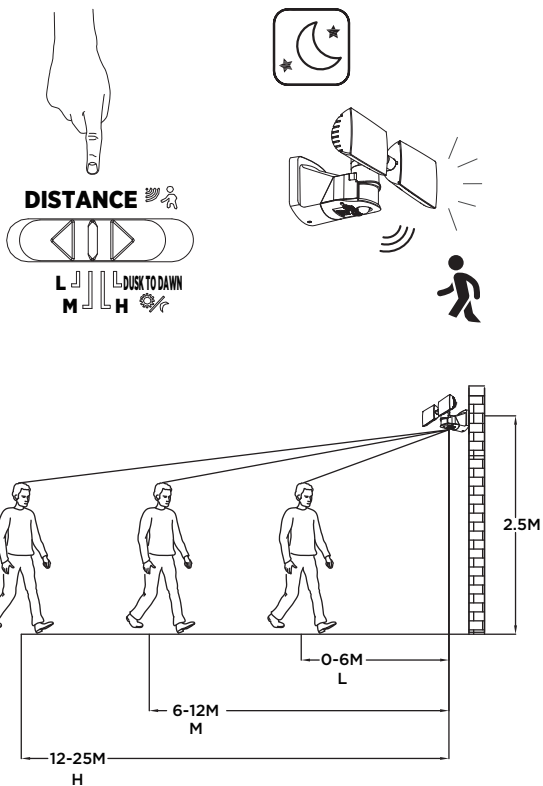

TEST setting

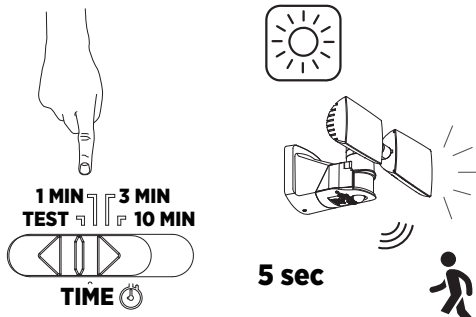

To adjust the detection zone in daylight. When the sensor detects movement the light turns on for 5 sec.

Einstellen des Erkennungsbereichs bei Tageslicht. Wenn der Sensor eine Bewegung erkennt, schaltet sich das Licht für 5 Sekunden ein.

Pour régler la zone de détection en plein jour. Lorsque le capteur détecte un mouvement, la lumière s'allume pendant 5 secondes.

Para ajustar la zona de detección a la luz del día. Cuando el sensor detecta movimiento, la luz se enciende durante 5 segundos.

Per regolare la zona di rilevamento alla luce del giorno. Quando il sensore rileva il movimento, la luce si accende per 5 secondi.

Om de detectiezone bij daglicht aan te passen. Wanneer de sensor beweging detecteert, wordt het licht gedurende 5 seconden ingeschakeld.

Aby dostosować strefę wykrywania w świetle dziennym. Gdy czujnik wykryje ruch, światło włącza się na 5 sekund.

Az érzékelési zóna beállítása a napfényben. Ha az érzékelő mozgást észlel, a lámpa 5 másodpercre bekapcsol.

TIME setting

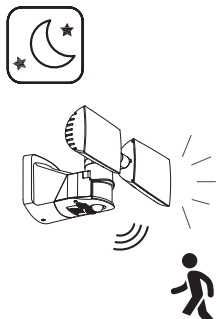
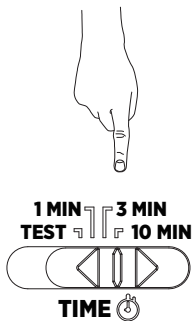

DUSK TO DAWN setting

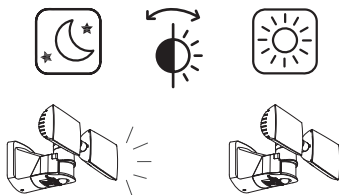
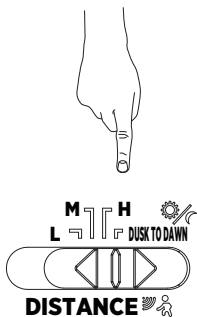

AMBIENT LIGHT setting

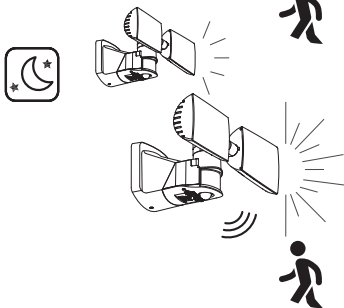
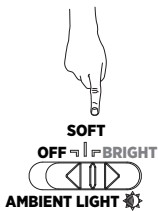
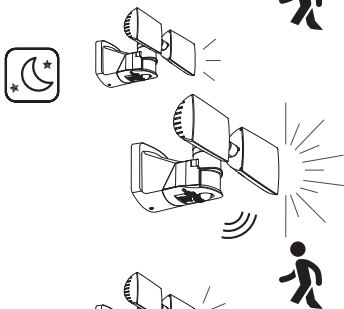
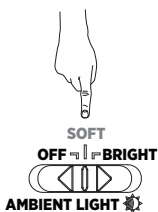
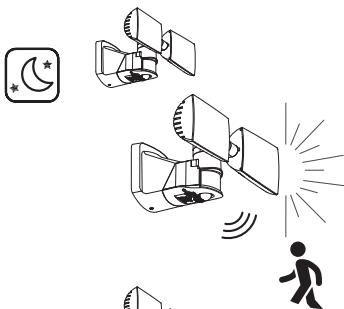
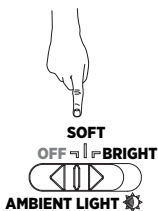

Operation

Betrieb/Utilisation/Funcionamiento/Funzionamento
Gebruik/Eksploatacja/Üzemeltetés/

- Weather conditions can influence sensor operation.
- Keep the sensor clean.
- Wetterbedingungen können den Betrieb des Sensors beeinflussen.
- Halten Sie den Sensor sauber.
- Les conditions météorologiques peuvent influencer sur le fonctionnement du capteur.
- Gardez le capteur propre.
- Las condiciones climáticas pueden influir en el funcionamiento del sensor.
- Mantenga el sensor limpio.
- Le condizioni meteorologiche possono influenzare il funzionamento del sensore.
- Mantenere il sensore pulito.
- Weersomstandigheden kunnen de werking van de sensor beïnvloeden.
- Houd de sensor schoon.
- Warunki pogodowe mogą wpływać na działanie czujnika.
- Utrzymuj czujnik w czystości.
- Az időjárási viszonyok befolyásolhatják az érzékelő működését.
- Tartsa tisztán az érzékelőt.



LUTEC Europe NV

Herentalsebaan 425
B-2160 Wommelgem - Belgium
+32 3 284 51 62
info@luteceurope.com
www.luteceurope.com



www.luteceurope.com/services/global-network