



1003573012423060184



KLARSTEIN

Chal-Tec GmbH

Wallstraße 16,
10179 Berlin, Germany
WEEE-Nr.: DE 46906833

Importer for Great Britain:
Berlin Brands Group UK Ltd
PO Box 1145
Oxford, OX1 9UW
United Kingdom

Item-Nr.: 10035730

Description: Thermoelectric cooler

Specifications:

Voltage/ Frequency: 220-240V AC / 50Hz

Power: 45W

Climate Class: SN, N

Storage Volume: 17L

Refrigerant (Weight): 36g

Foaming Gas: C-PENTANE

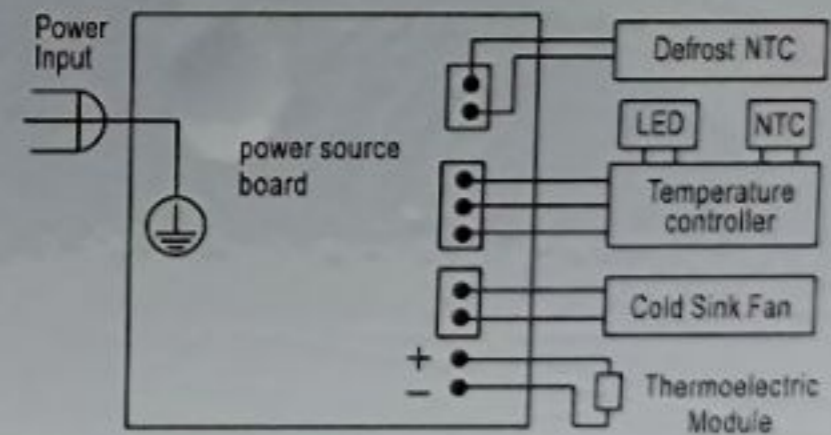

Circuit diagram