

TRASMAN

DESIGNED & MADE IN
100%
BARCELONA

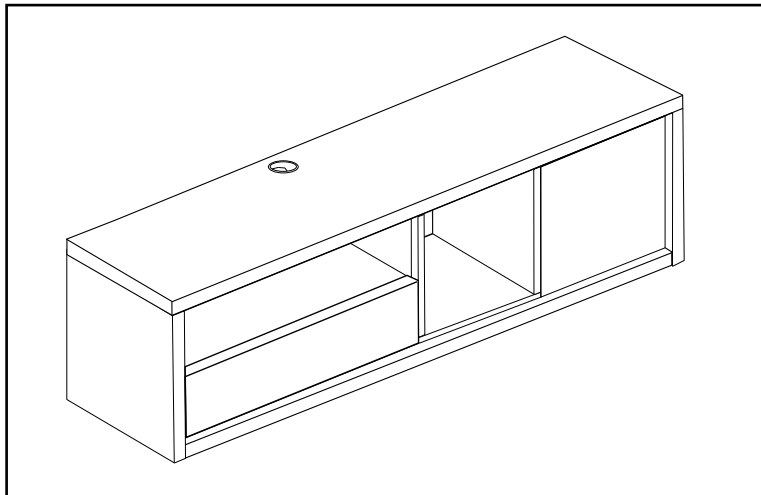

MANUAL DE MONTAJE
NOTICE DE MONTAGE
ASSEMBLY MANUAL
MANUALE PER IL MONTAGGIO
MONTAGEANLEITUNG
MANUAL DE MONTAGEM
INSTRUKCJE MONTAŻOWE

1473 FRAME

V.01 - 02/19

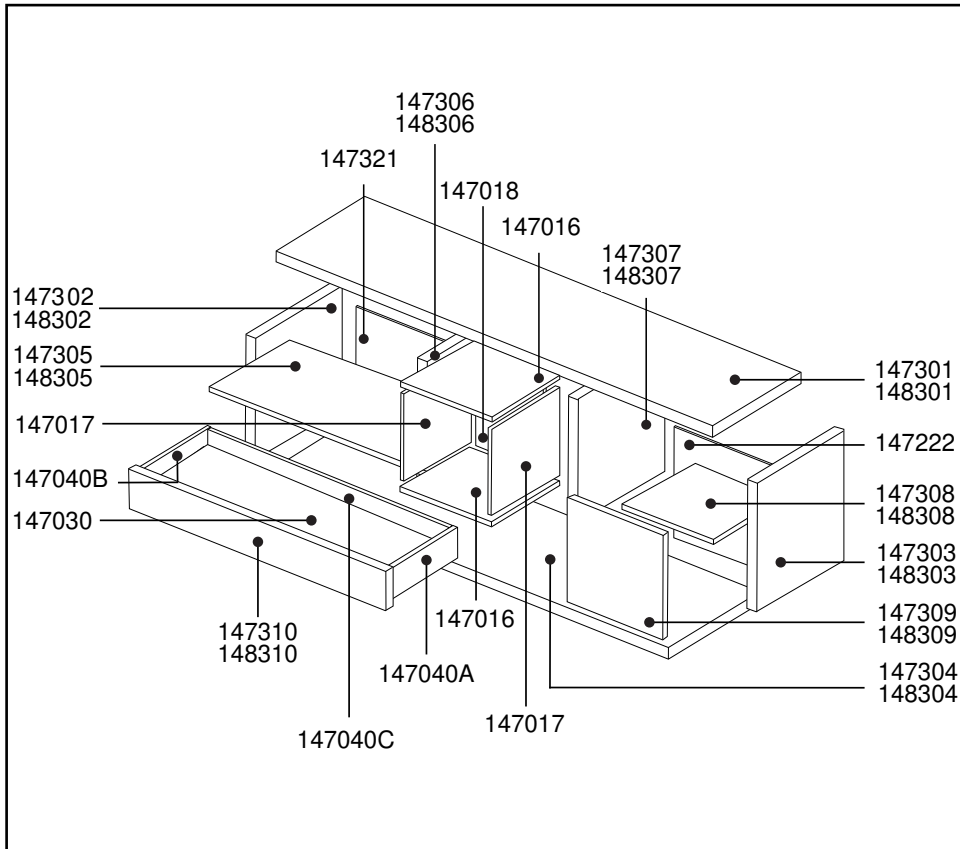
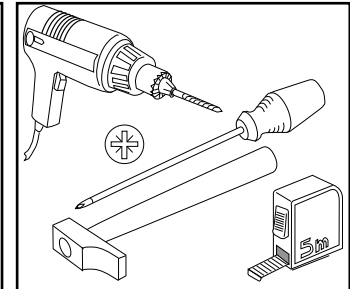
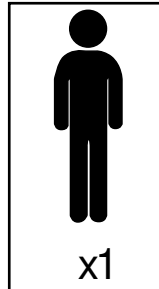
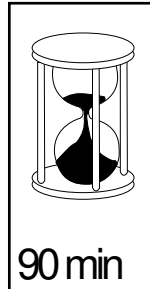

**ANTES DE EMPEZAR
CONSULTE LOS CONSEJOS
PARA EL MONTAJE.**

**AVANT DE COMMENCER
CONSULTEZ LES
INSTRUCTIONS DE MONTAGE.**

**BEFORE STARTING REFER TO
THE ASSEMBLY ADVICE.**

**PRIMA DI INIZIARE LEGGERE
I CONIGLI PER IL MONTAGGIO.**

**VOR DEM BEGINN EMPFIEHLT
ES SICH AUFMERKSAM DIE
HINWEISE ZUR MONTAGE ZU
LESEN.**

**ANTES DE COMEÇAR
CONSULTE OS CONSELHOS
PARA A MONTAGEM.**

**ZANIM PRZYSTAPIMY DO
MONTAŻU, PROSIMY
ZAPOZNAC SIE Z
NASTĘPUJĄCYMI
WSKAZÓWKAMI.**

x16 PE845	x8 EX25	x8 EX19	x8 TE17*	x20 CL830	x18 CL530	x4 TA760	x1 LLA4	x4 PE12	x4 EX12	x4 PE3	x16 TP3515	x12 TV3135	x2 B35SU	x2 BA35S	x1 CIPL
x1 COLA	x60 P1030	x6 PN826	x6 T8*	x1 GQE400	x1 PC60N										

Español (es) - Información importante sobre el montaje de los muebles en pared, leer detenidamente y guardar esta información para consultarla en el futuro.

ADVERTENCIA

Una vez montado según las instrucciones de montaje, el mueble está listo para fijarlo a la pared. Pueden producirse lesiones graves o fatales si vuelca un mueble. Para evitar que vuelque este mueble, debe fijarse permanentemente a la pared. Trasman Penedès no se hace responsable de daños personales ocasionados por un montaje de pared incorrecto.

No están incluidos los tornillos para montaje en pared. Póngase en contacto con su ferretero local que le asesorará en la elección del sistema de tornillos correcto para el tipo de material de pared, dado que los diversos materiales de pared requieren diferentes tipos de herrajes de fijación.

Français (fr) - Informations importantes concernant le montage mural de notre mobilier, a lire attentivement, conserver ces informations pour un usage ultérieur.

AVERTISSEMENT

Après avoir assemblé votre meuble en suivant le mode d'emploi, vous pouvez le monter au mur. Risque de blessure grave en cas de chute du meuble. Pour éviter que le meuble ne bascule, il faut le fixer au mur de façon permanente. Trasman Penedes décline toute responsabilité en cas de blessures ou de dommages matériels dus à un montage mural incorrect.

Aucune vis n'est fournie pour le montage mural. Contactez votre quincaillier local pour sélectionner une visserie adaptée au matériau de construction de votre mur, car leur choix dépend du matériau du mur sur lequel est fixé le meuble.

English (en) - Important information concerning wall mounting of furniture, read carefully and keep this information for further reference.

WARNING

After you have assembled this product according to the assembly instructions, it can be mounted on a wall. Serious or fatal crushing injuries can occur from furniture tip-over. To prevent this furniture from tipping over it must be permanently fixed to the wall. Trasman Penedes cannot be held liable for personal or material injury as a result of incorrect mounting.

Screws for wall mounting are not included. Please contact your local specialist to ensure the correct choice of screws in relation to the wall material since different wall materials require different types of fixing devices. Use fixing devices suitable for the walls in your home.

Italiano (it) - Informazioni importanti per il fissaggio alla parete dell'armadietto per le scarpe, leggi attentamente e conserva queste informazioni per ulteriori consultazioni.

AVVERTENZA

Durante il montaggio questo armadietto per le scarpe andrà fissato alla parete. Se il mobile si ribalta può causare lesioni da compressione serie o fatali. Per prevenire il rischio che il mobile si ribalti permanentemente alla parete. Trasman Penedes non potrà essere ritenuto responsabile dei danni a persone o cose dovuti ad un montaggio non corretto.

Le viti per il fissaggio a parete non sono in dotazione. Rivolgersi al locale negoziante specializzato per essere sicuri che le viti corrispondano al materiale della parete perché pareti di materiali diversi richiedono tipi diversi di accessori di fissaggio.

Deutsch (de) - Wichtige Information betr. Wandbefestigung des Schuhschranks, sorgfältig lesen, diese Information aufbewahren

ACHTUNG

Beim Zusammenbau dieses Schrankes müssen Sie das Möbelstück an der Wand befestigen. Wenn Möbelstücke umkippen, können ernste oder lebensgefährliche Verletzungen durch Einklemmen die Folge sein. Um zu verhindern, dass das Möbelstück umkippt, muss es fest an der Wand verankert werden. Trasman Penedes haftet nicht für Personen- oder Sachschäden, die auf eine unsachgemäße Wandmontage zurückgeführt werden können.

Schrauben für die Wandmontage gehören nicht zum Lieferumfang. Für die korrekte Wahl eines für das jeweilige Wandmaterial geeigneten Schraubensystems wenden Sie sich bitte an den Fachhandel vor Ort, da dieses von der jeweiligen Wandbeschaffenheit abhängig ist.

Português (pt) - Informação importante relativa a montagem na parede do móvel, ler estas instruções cuidadosamente, guardar como referência.

IMPORTANTE

Depois de ter montado o móvel de acordo com as instruções de montagem, pode fixá-lo à parede. As quedas de móveis podem originar esmagamento ou morte. Estes móveis devem ser fixados à parede para evitar possíveis quedas. Trasman Penedes não se responsabiliza por ferimentos pessoais ou danos materiais ou danos como resultado da montagem incorrecta.

Os parafusos necessários para fixar o móvel à parede não estão incluídos. Por favor, contacte o seu especialista local para garantir a escolha correcta de parafusos em relação ao material, os diferentes tipos de parede requerem diferentes tipos de ferragens.

ESPAÑOL

CONSEJOS PARA EL MONTAJE:

- 1-ESTUDIE ATENTAMENTE EL MANUAL DE MONTAJE.
- 2-LOCALICE LAS PIEZAS QUE CONSTITUYEN SU MUEBLE.
- 3-REUNA Y CONTROLE LOS HERRAJES SUMINISTRADOS.
- 4-EQUIPESE CON LAS HERRAMIENTAS NECESARIAS.
- 5-PREPARE UNA ZONA DE MONTAJE.

CONSEJOS PARA EL MANTENIMIENTO:

- 1-QUITAR EL POLVO CUIDADOSAMENTE.
- 2-HUMEDECER UN PAÑO SUAVE Y LIMPIO CON AGUA LIGERAMENTE ENJABONADA.

NO FUERCE NUNCA EN LAS UNIONES APRIETE LOS TORNILLOS DESPUES DE CIERTO TIEMPO DE UTILIZACION.
CONSERVE SU MANUAL DE MONTAJE.SI FALTARA UNA PIEZA SERIA LA MANERA MAS FACIL DE COMUNICARLO A LA TIENDA.

NO USE NUNCA PRODUCTOS ABRASIVOS TALES COMO:
LANA DE ACERO , LIJAS,DISOLVENTES,ETC.
NO MOJAR NI SOMETER A GRANDES HUMEDADES AL MUEBLE.

FRANCAIS

INSTRUCTIONS DE MONTAGE:

- 1-LISEZ ATTENTIVEMENT LA NOTICE DE MONTAGE.
- 2-REPEREZ LES PIECES QUI COMPOSENT VOTRE MEUBLE.
- 3-REGROUPEZ ET VERIFIEZ LES FERRURES FOURNIES.
- 4-DOTEZ-VOUS DES OUTILS NECESSAIRES.
- 5-PREPAREZ UN ESPACE DE MONTAGE.

CONSEILS D'ENTRETIEN:

- 1-ENLEVEZ SOIGNEUSEMENT LA POUSSIERE.
- 2-HUMIDIFIEZ UN CHIFFON DOUX ET PROPRE AVEC DE L'EAU LIGEREMENT SAVONNEUSE.

NE FORCEZ JAMAIS LES RACCORDS. RESSERREZ LES VIS APRES UN CERTAIN TEMPS D'UTILISATION.
CONSERVEZ LA NOTICE DE MONTAGE.EN CAS DE PIECE MANQUANTE , CE SERA LE MEILLEUR MOYEN D'EN INFORMER LE MAGASIN.

N'UTILISEZ JAMAIS DES PRODUITS ABRASIFS COMME DE LA LAINE D'ACIER, DU PAPIER DE VERRE, DES SOLVANTS, ETC.
NE MOUILLEZ PAS LE MEUBLE ET EVITEZ TOUTE EXPOSITION A UNE HUMIDITE IMPORTANTE.

DEUTSCH

HINWEISE ZUR MONTAGE:

- 1- LESEN SIE AUFMERKSAM DIE MONTAGEANLEITUNG DURCH.
- 2- LOKALISIEREN SIE DIE ZUM MÖBEL GEHÖRENDE TEILE.
- 3- KONTROLLIEREN SIE DIE MITGELIEFERTEN WERKZEUGE.
- 4- RÜSTEN SIE SICH MIT DEN ZUSÄTZLICH BENÖTIGTEN WERKZEUGEN AUS.
- 5- BEREITEN SIE EINEN PLATZ FÜR DIE MONTAGE VOR.

HINWEISE ZUR PFLEGE:

- 1- ENTFERNEN SIE UMSICHTIG DEN ANGESAMMELTEN STAUB.
- 2- VERWENDEN SIE EIN WEICHES UND SAUBERES TUCH UND SCHWACHE SEIFENLAUGE.

FORCIEREN SIE NIEMALS DIE VERBINDUNGEN. ZIEHEN SIE DIE SCHRAUBEN NACH EINER BESTIMMTEN NUTZUNGSZEIT NACH.
BEWAHREN SIE DIE MONTAGEANLEITUNG AUF. SOLLTE EIN TEIL FEHLEN IST SIE VON GROSSER WICHTIGKEIT BEI DER NACHBESTELLUNG IM LADEN.

VERWENDEN SIE NIEMALS SCHEUERENDE PRODUKTE WIE STAHLWOLLE, SCHMIRGELPAPIER, LÖSUNGSMITTEL UND DERGL.
WASSER UND HOHE FEUCHTIGKEIT SIND SCHÄDLICH FÜR DAS MÖBEL.

ITALIANO

CONSIGLI PER IL MONTAGGIO:

- 1- STUDIARE ATTENTAMENTE IL MANUALE DI MONTAGGIO.
- 2- INDIVIDUARE LE PARTI CHE COSTITUISCONO IL MOBILE.
- 3- RACCOGLIERE E CONTROLLARE GLI ATTREZZI IN DOTAZIONE.
- 4- PROCURARSI GLI ATTREZZI NECESSARI.
- 5- PREPARARE UNA ZONA PER IL MONTAGGIO.

CONSIGLI PER LA MANUTENZIONE:

- 1- SPOLVERARE ACCURATAMENTE.
- 2- INUMIDIRE UN PANNINO MORBIDO E PULITO CON ACQUA E POCO DETERGENTE.

NON FORZARE MAI LE GIUNTURE. STRINGERE NUOVAMENTE LE VITI DOPO UN CERTO PERIODO D'USO.
CONSERVARE IL MANUALE DI MONTAGGIO: SE MANCASSE UN PEZZO SAREBBE COSÌ PIÙ FACILE COMUNICARLO AL RIVENDITORE.

NON USARE MAI PRODOTTI ABRASIVI COME: SPUGNE ABRASIVE, CARTA VETRATA, SOLVENTI, ECC.
NON BAGNARE NE' SOTTOPORRE IL MOBILE A FORTE UMIDITÀ.

POTUGUES

CONSELHO PARA A MONTAGEM :

- 1 - ESTUDE ATENTAMENTE O MANUAL DE MONTAGEM.
- 2 - LOCALIZE AS PEÇAS QUE CONSTITUEM O SEU MÓVEL.
- 3 - REUNA E CONTROLE AS FERRAGENS FORNECIDAS.
- 4 - EQUIPE-SE COM AS FERRAMENTAS NECESSÁRIAS.
- 5 - PREPARE UMA ZONA DE MONTAGEM.

CONSELHOS PARA A MANUTENÇÃO :

- 1- RETIRAR A POEIRA COM CUIDADO.
- 2- HUMEDECER UM PANO SUAVE E LIMPO COM ÁGUA LIGEIRAMENTE ENSABOADA.

NUNCA FORCE AS UNIÕES. APORTE OS PARAFUSOS DEPOIS DE DETERMINADO TEMPO DE UTILIZAÇÃO..
CONSERVE O SEU MANUAL DE MONTAGEM, SE FALTAR UMA PEÇA SERIA A MANEIRA MAIS FÁCIL DE A COMUNICAR À LOJA.

NUNCA USE PRODUTOS ABRASIVOS TAIS COMO : LÃ DE AÇO, LIXAS, DISSOLVENTES, ETC..
NÃO MOLAR NEM SUBMETER A GRANDES HUMIDADES, O MÓVEL.

POLSKU

WSKAZÓWKI ODNOŚNIE MONTAZU:

1. PRZECZYTAĆ UWAGNIE NINIEJSZE ZALECENIA.
2. ZLOKALIZOWAĆ CZĘŚCI SKŁADOWE MEBLA.
3. ZEBRAĆ WSZYSTKIE ELEMENTY ŁĄCZĄCE.
4. ZAOPATRYĆ SIĘ W NIEZBEDNE NARZĘDZIA.
5. PRZYGOTOWAĆ ODPOWIEDNIE MIEJSCA NA MONTAZ.

WSKAZÓWKI ODNOŚNIE KONSERWACJI:

1. ODKURZAC OSTROŻNIE.
2. W TYM CELU ZWILŻYĆ CZYSTĄ MIEKKĄ SZMATKĘ W SŁABYM ROZTWORZE WODY Z MYDŁEM.

NIE DOCISKAC NA SIŁE ELEMENTÓW ŁĄCZĄCYCH. DOKRECIĆ SRUBY PO UPLYWIE PEWNEGO CZASU.
ZACHOWAĆ INSTRUKCJE MONTAZOWE; W RAZIE BRAKU JAKIEJS CZĘŚCI, UŁATWIA ONE KONTAKT ZE SPRZEDAWCĄ.

NIE NALEŻY NIGDY UŻYWAĆ ŚRODKÓW SZORUJĄCYCH, TAKICH JAK WELNA STALOWA, PAPIER SCIERNY, ROZPUSZCZALNIKI ITP.
NIE MOCZYĆ ANI NIE PODDAWAĆ MEBLA DZIAŁANIU DUŻEJ WILGOTNOŚCI.

ENGLISH

ASSEMBLY ADVICE:

- 1- STUDY THE ASSEMBLY MANUAL CAREFULLY.
- 2- LOCATE THE PARTS THAT COMPRISE YOUR FURNITURE ITEM.
- 3- ORGANISE AND CHECK THE FITTINGS SUPPLIED.
- 4- HAVE THE NECESSARY TOOLS TO HAND.
- 5- PREPARE AN ASSEMBLY AREA.

MAINTENANCE ADVICE:

- 1- REMOVE DUST CAREFULLY.
- 2- MOISTEN A SOFT, CLEAN CLOTH WITH SLIGHTLY SOAPY WATER.

DO NOT FORCE ANY OF THE JOINTS. TIGHTEN THE SCREWS AFTER HAVING USED THE FURNITURE FOR SOME TIME.
KEEP YOUR ASSEMBLY MANUAL. IF ANY PART IS MISSING, IT WILL HELP YOU TO LET THE SHOP KNOW.

NEVER USE ABRASIVE PRODUCTS SUCH AS STEEL WOOL, SANDPAPER, ETC.
DO NOT WET THE FURNITURE OR KEEP IT IN A VERY DAMP PLACE.

1/3

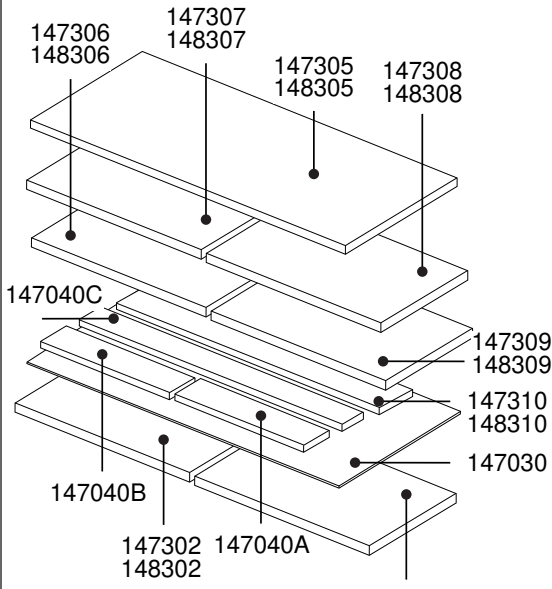

T1 T2
T3 X
Y Z

1473A / 1483A

2/3

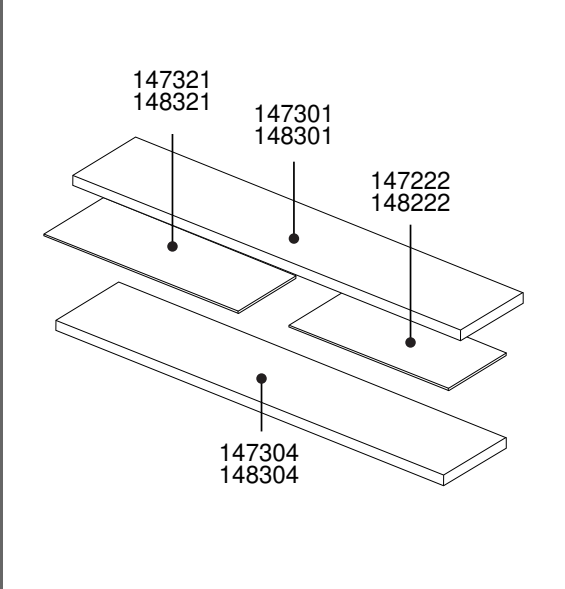

1473B / 1483B

3/3

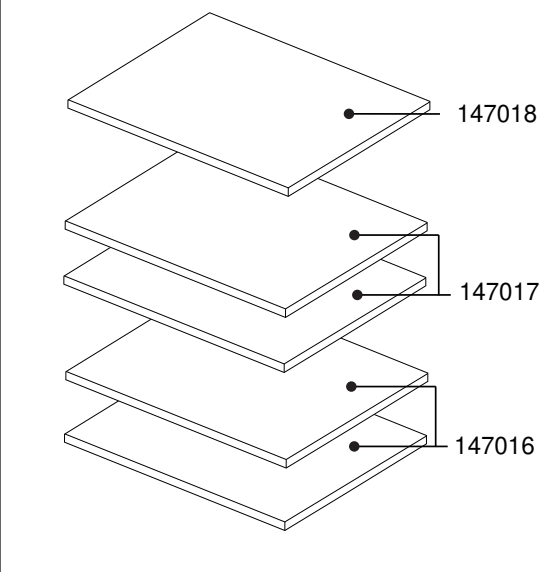

1470E / 1480E

T1

x16

x8

x8

x8

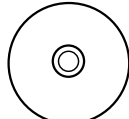
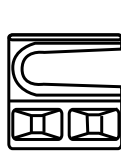
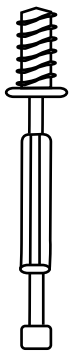

PE845

EX25

EX19

TE17RN
TE17RD

T2

x20

x18

x4

x16

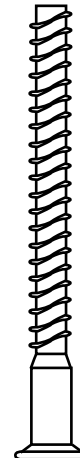

CL830

CL530

TA760

TP3515

T3

x4

x4

x4

x12



EX12

PE12

PE3

TV3135

X

x2

x2

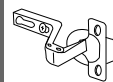

B35SA

BA35S

Z

x1

x1

x60

x6

x1

x6

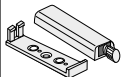

CIPL

COLA

P1030

PN826

LLA4

T8RN
T8RD

1



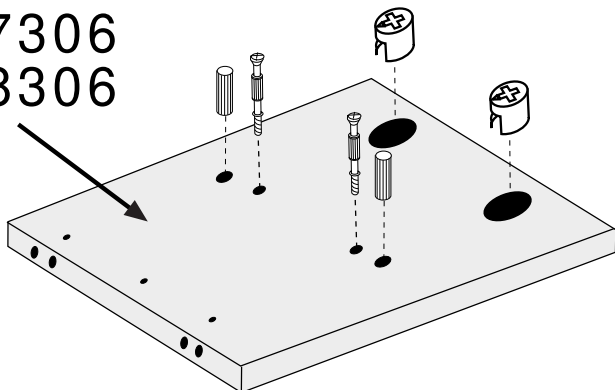

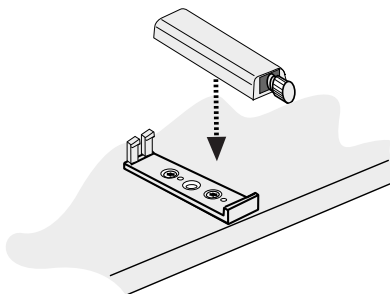
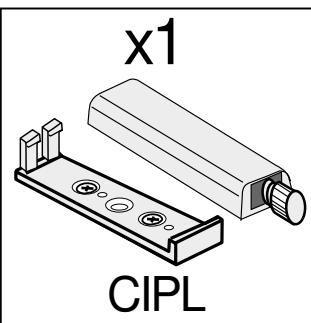
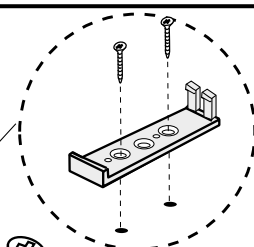
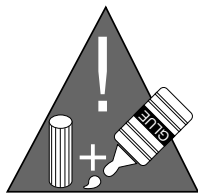
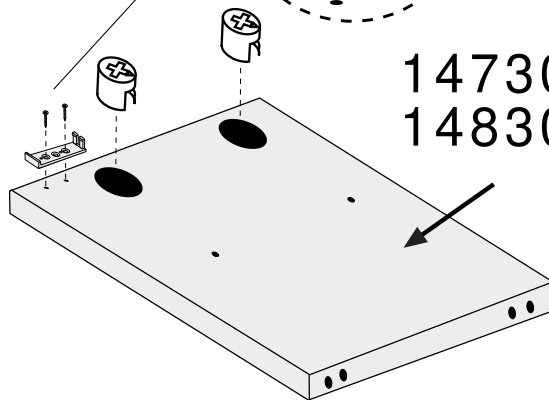

147306
148306

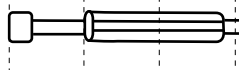

147307
148307

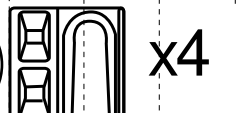

cm 0 1 2 3 4 5

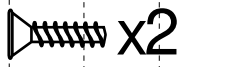

- PE845   x2
- CL830   x2
- EX19   x4
- TV3135   x2

2

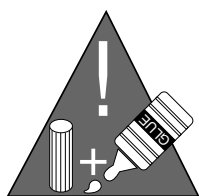
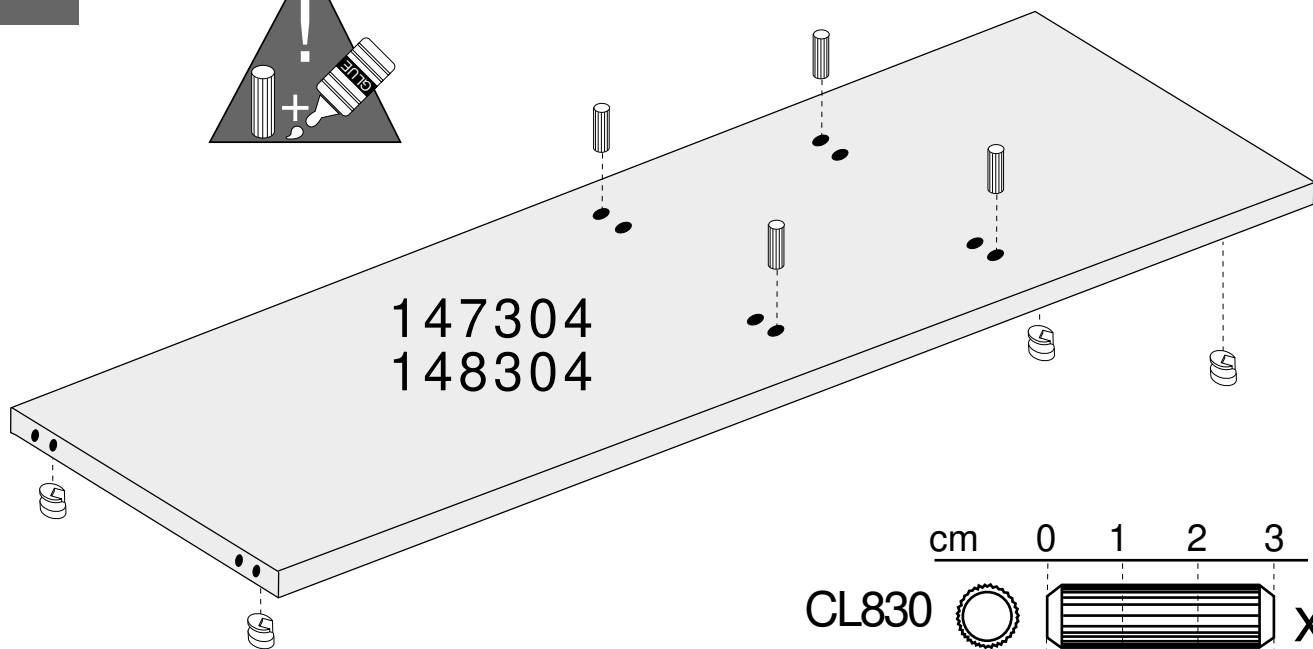
147304
148304

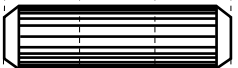

cm 0 1 2 3

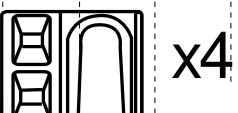
- CL830   x4
- EX25   x4

3

147306
148306

147307
148307

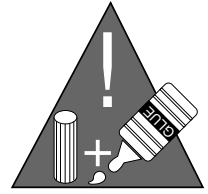
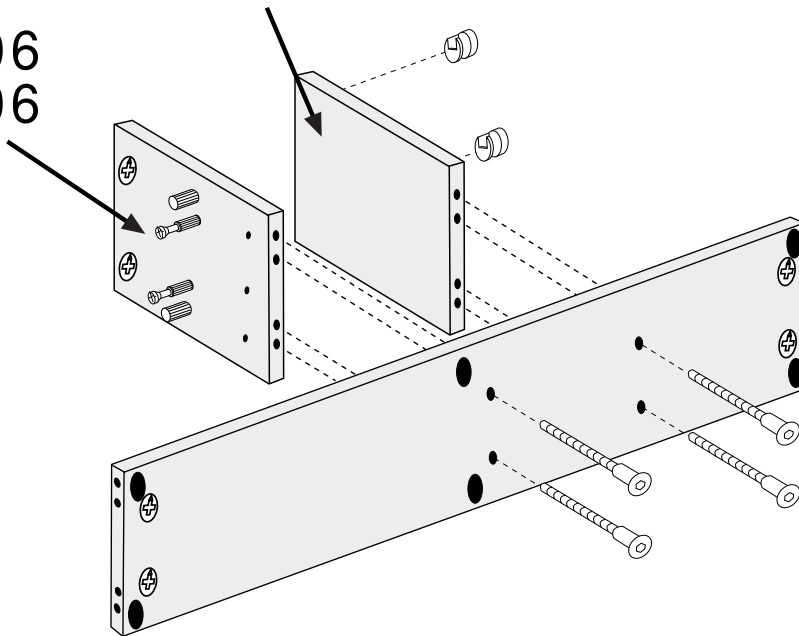

cm 0 1 2 3 4 5 6

TA760  x4

EX19  x2

4

147305
148305

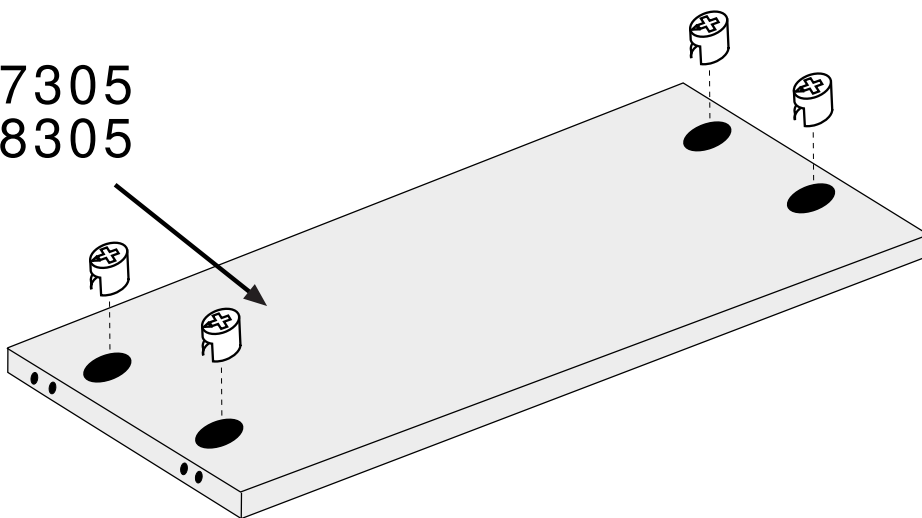

cm 0 1 2

EX19  x4

5

147306
148306

147305
148305

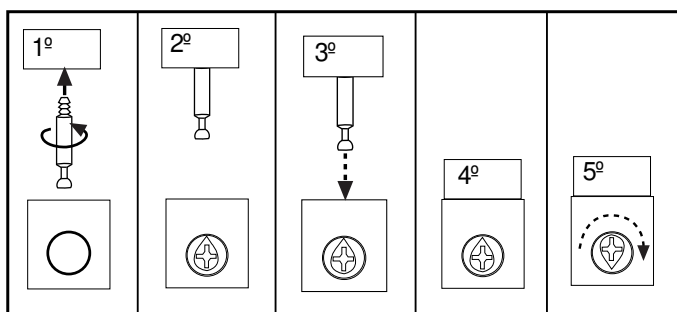
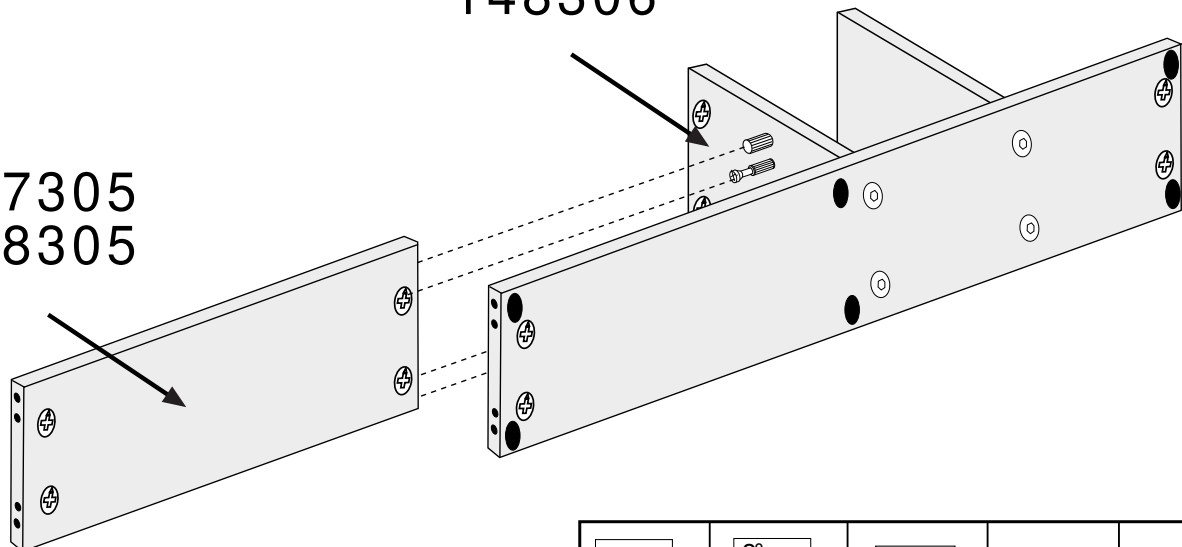

6

147302
148302

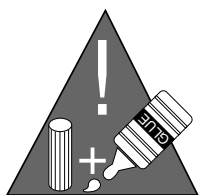
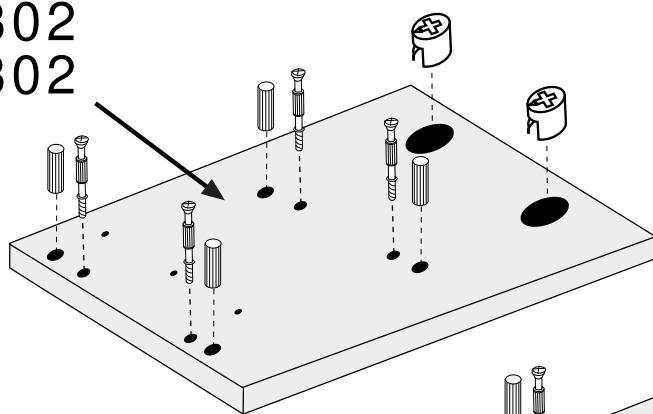

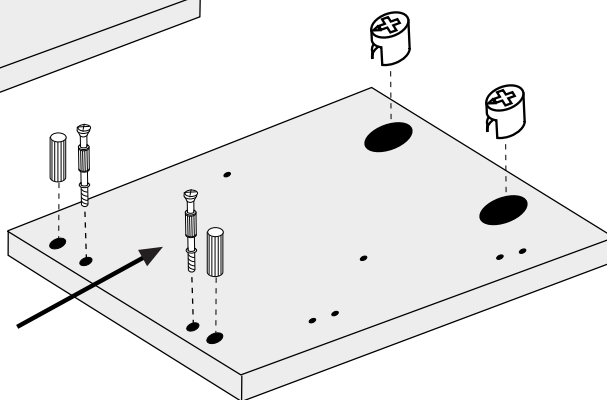

147303
148303

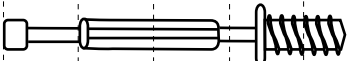

cm 0 1 2 3 4 5

PE845   x6

CL830   x6

EX25   x4

7

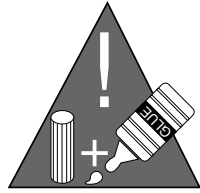

147303
148303

147302
148302

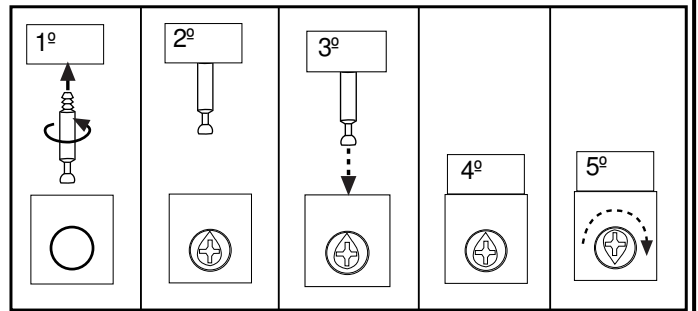
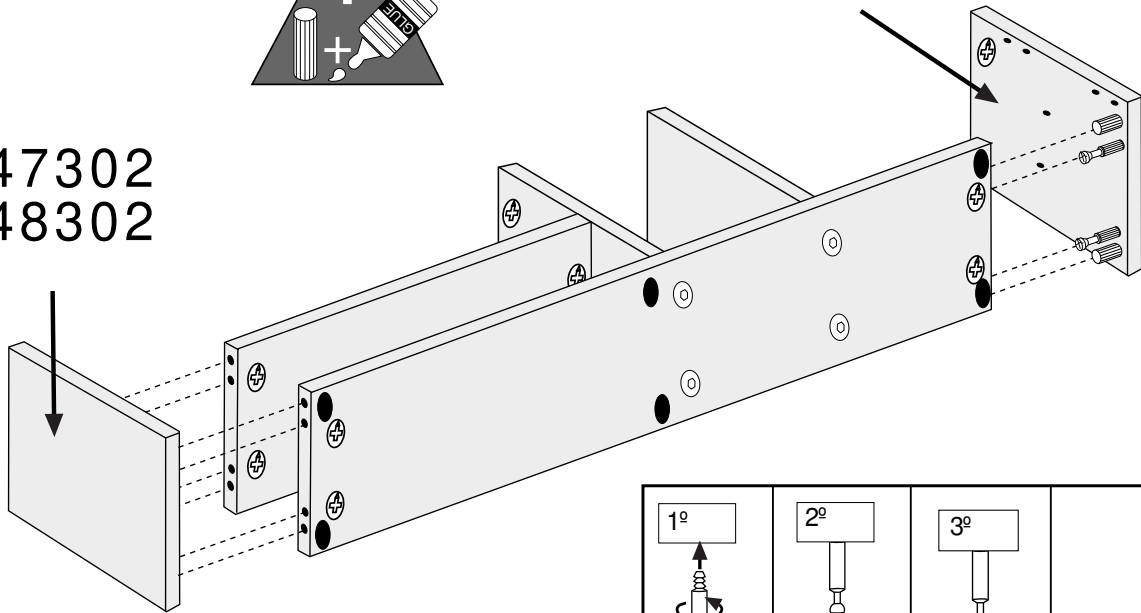

8

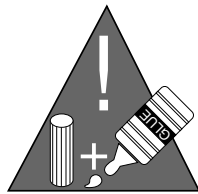

147301
148301

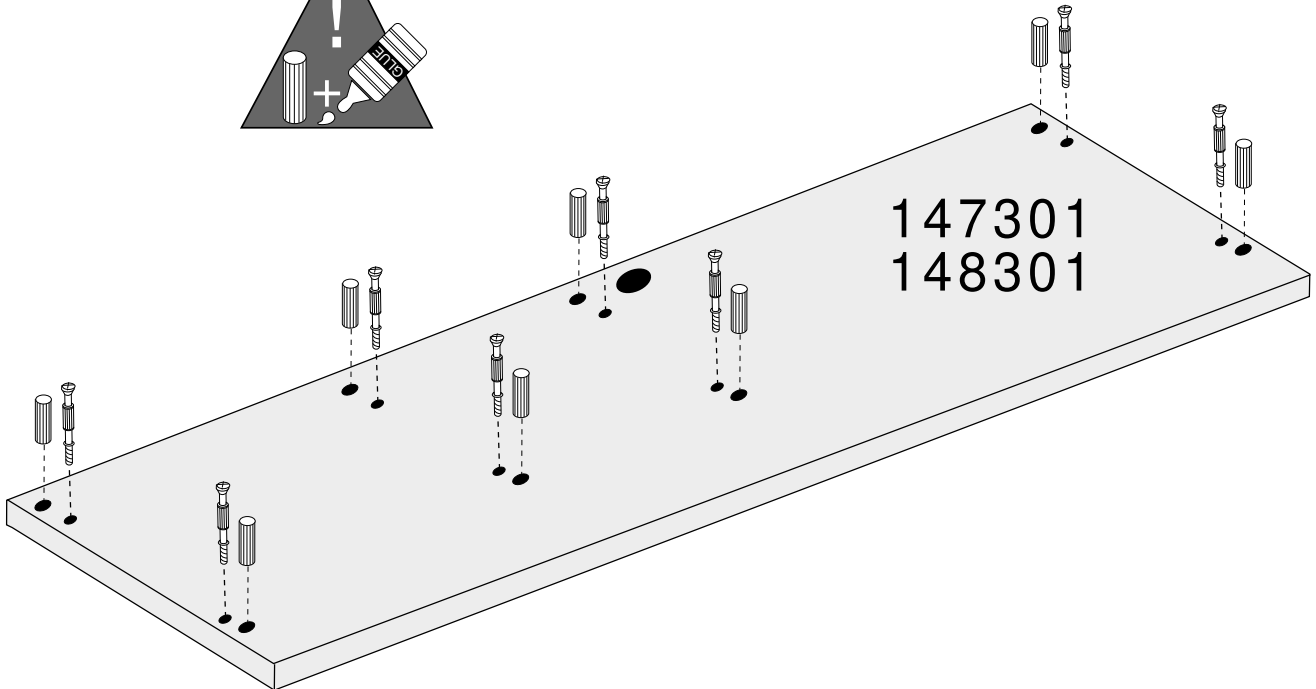

cm 0 1 2 3 4 5

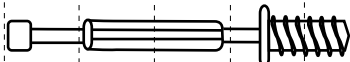
PE845   x8

CL830   x8

9

147301
148301

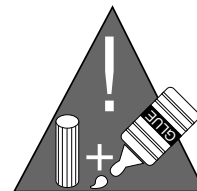
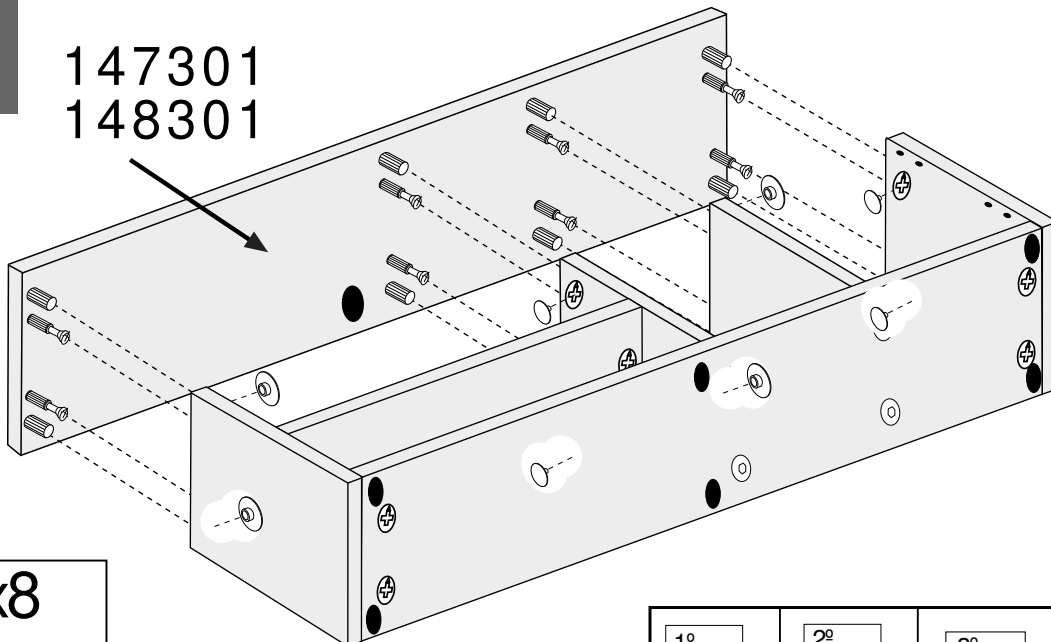

x8



TE17RN
TE17RD

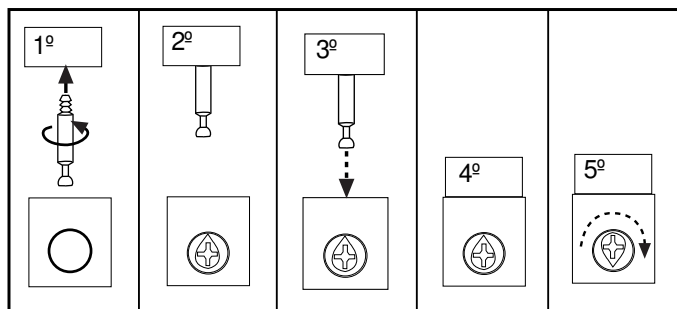
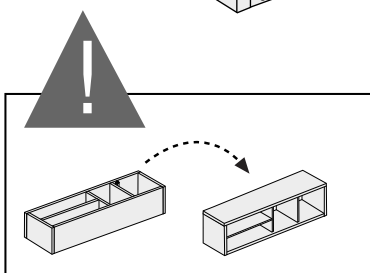

10

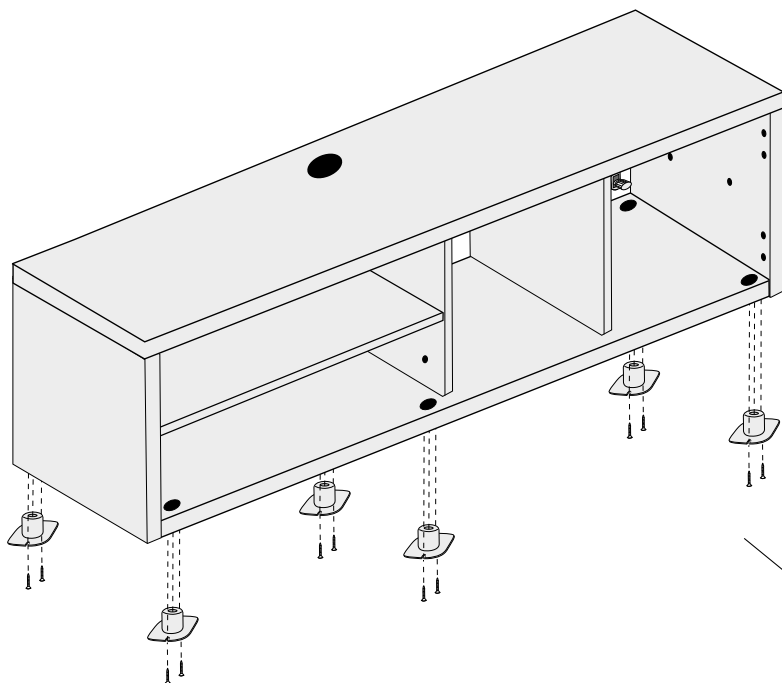

x6



PN826



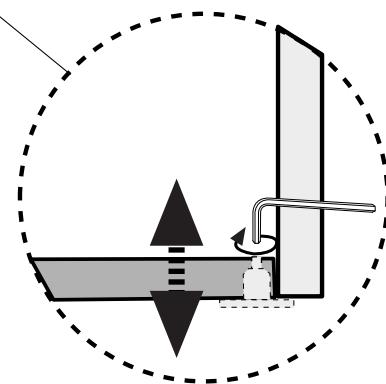
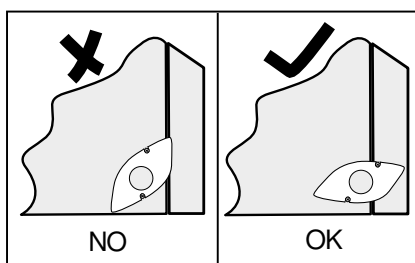

cm 0 1 2

TP3515  x12

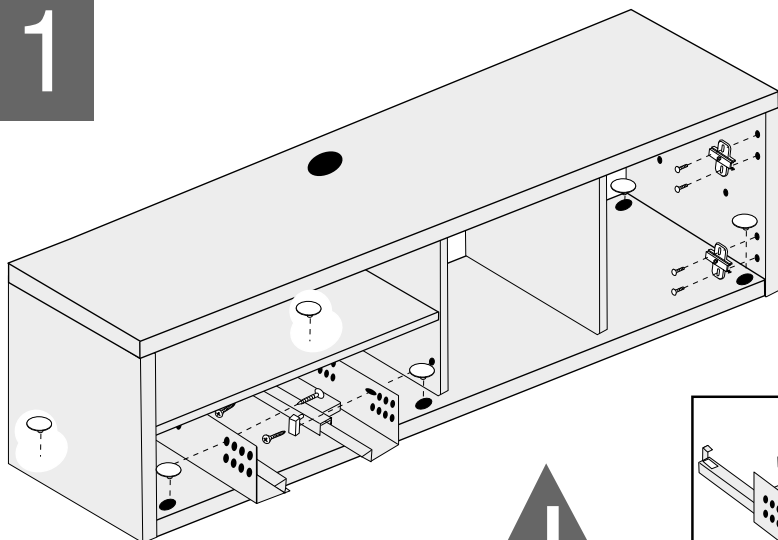

11

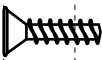

cm 0 1 2
TV3135   x10

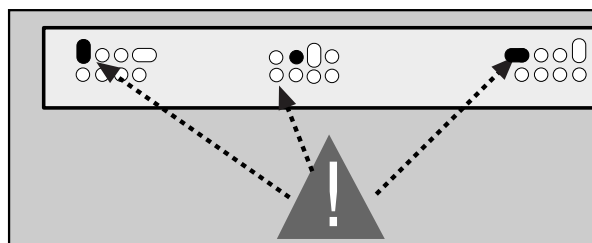
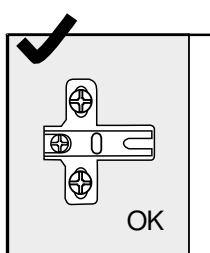
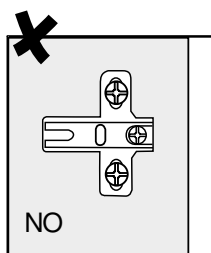
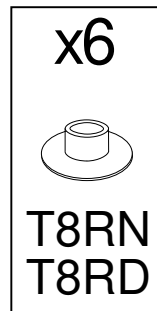
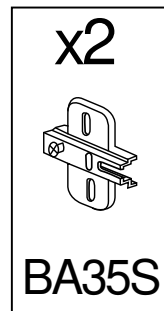
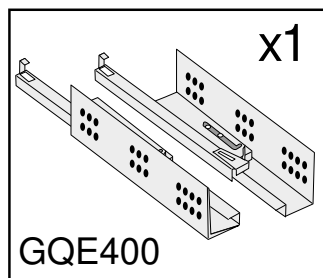

12

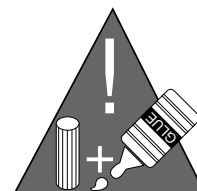
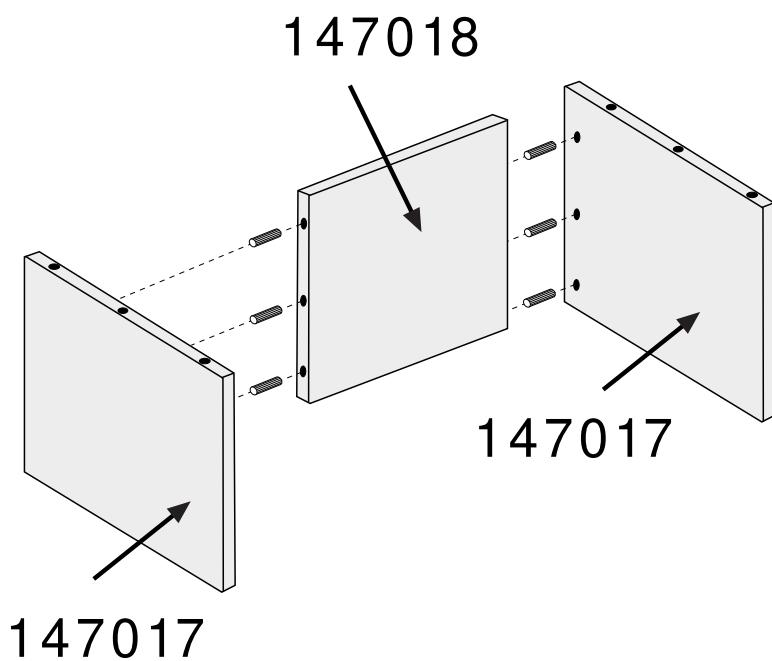

cm 0 1 2 3 4

CL530   x6

13

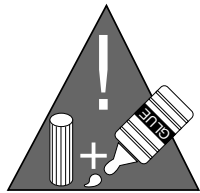
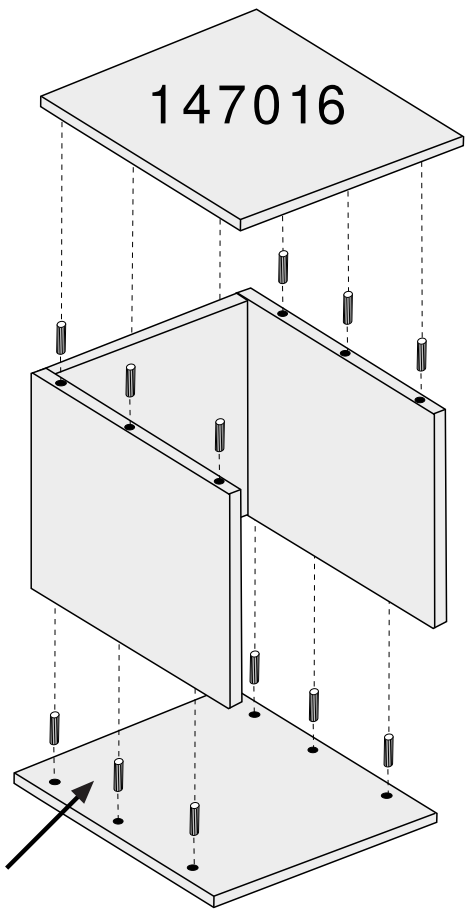
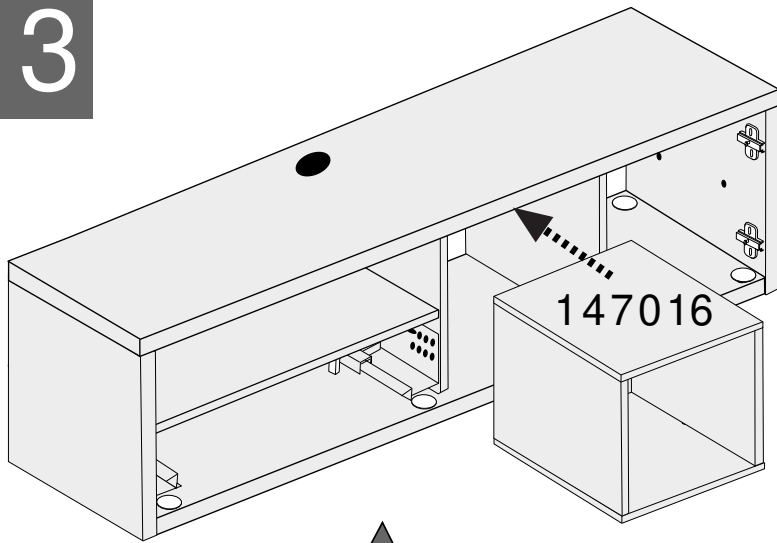

cm 0 1 2 3 4

CL530



x12

147016

14

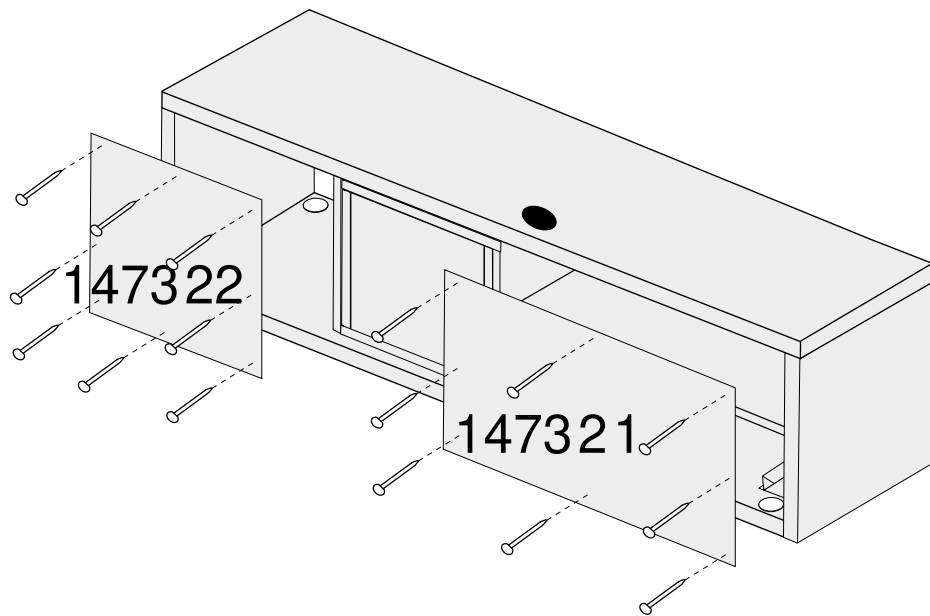

x60



P1030

15

147310
148310

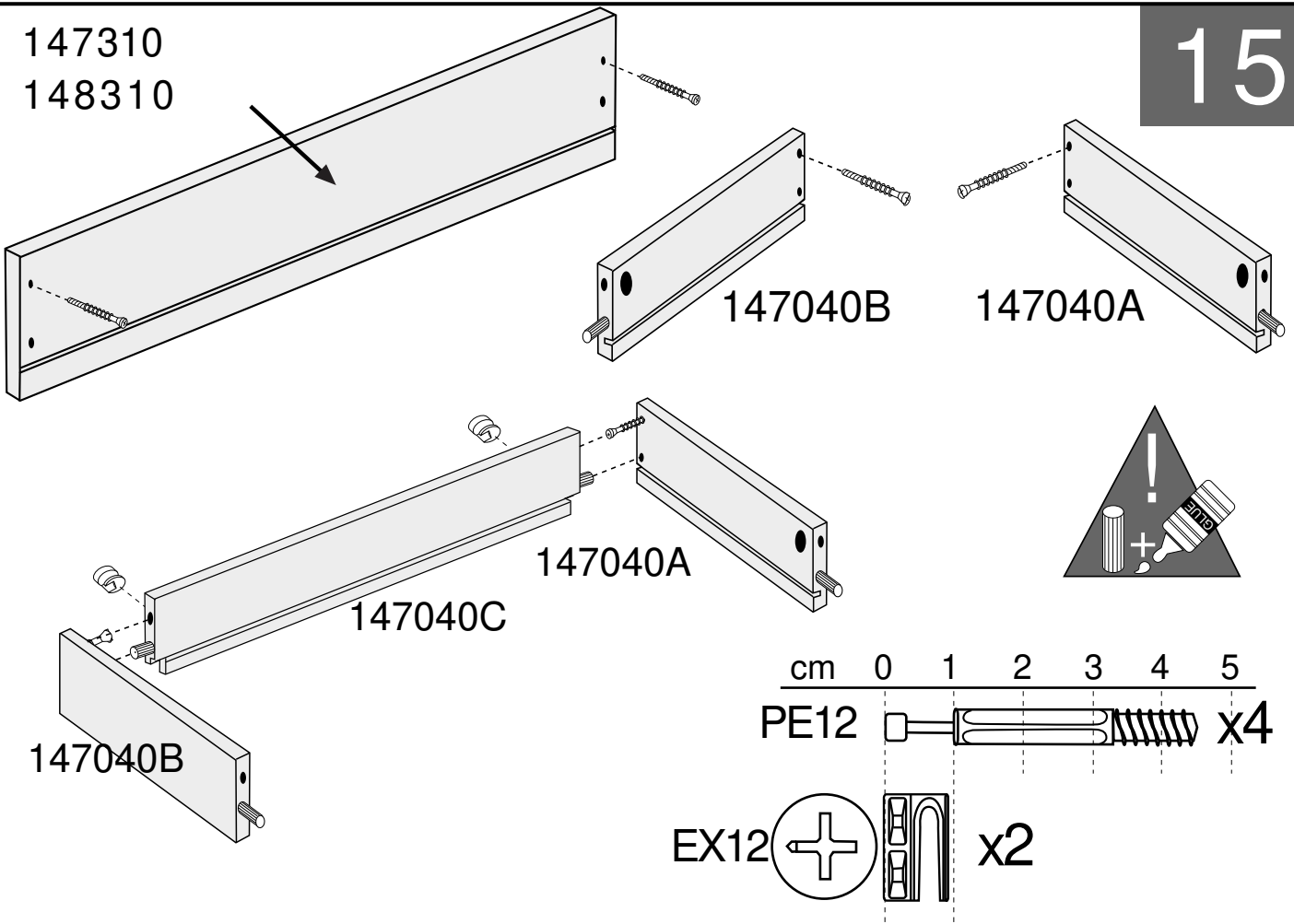

16

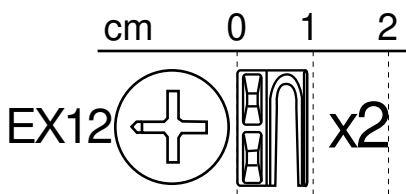
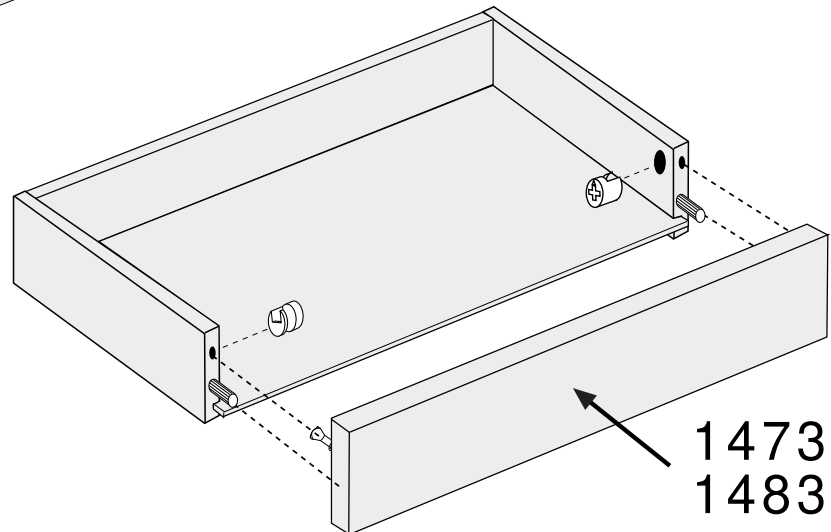
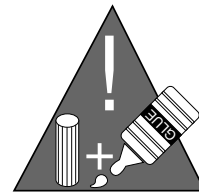
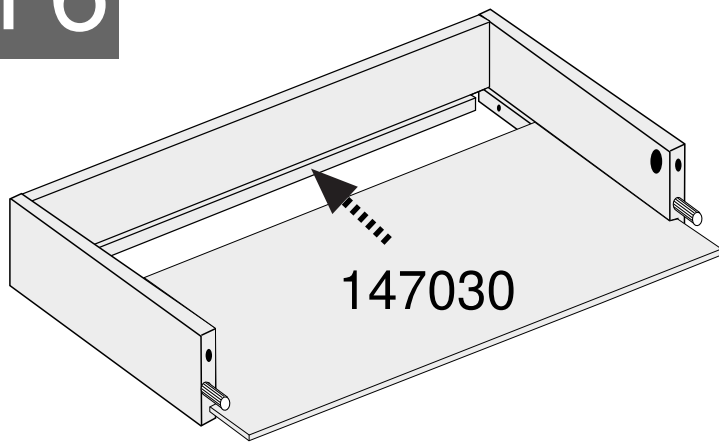

17

cm 0 1 2

TP3515  x4

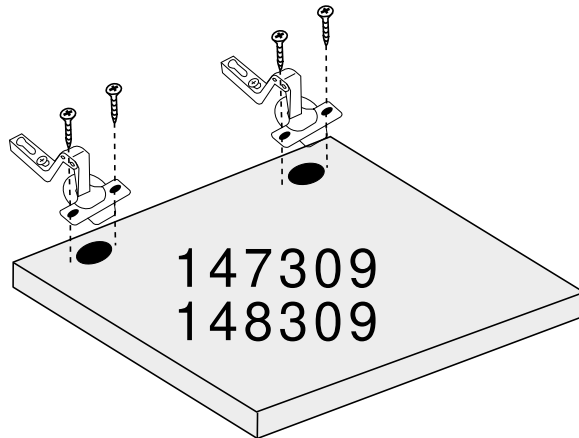

x2

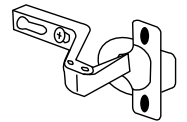

B35SU

18

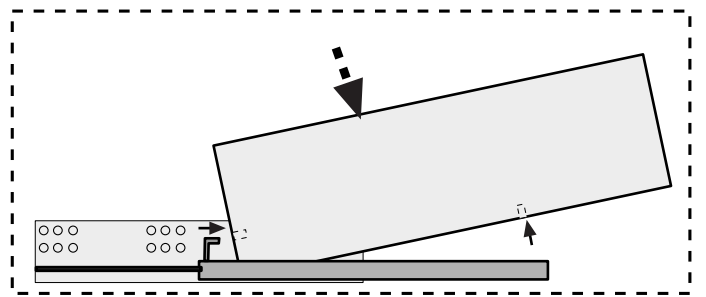
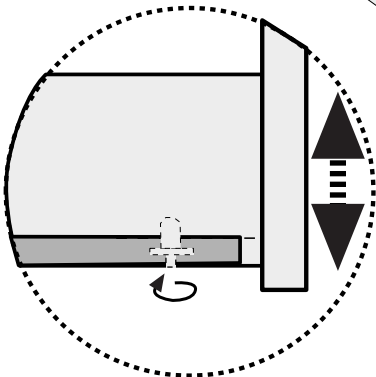
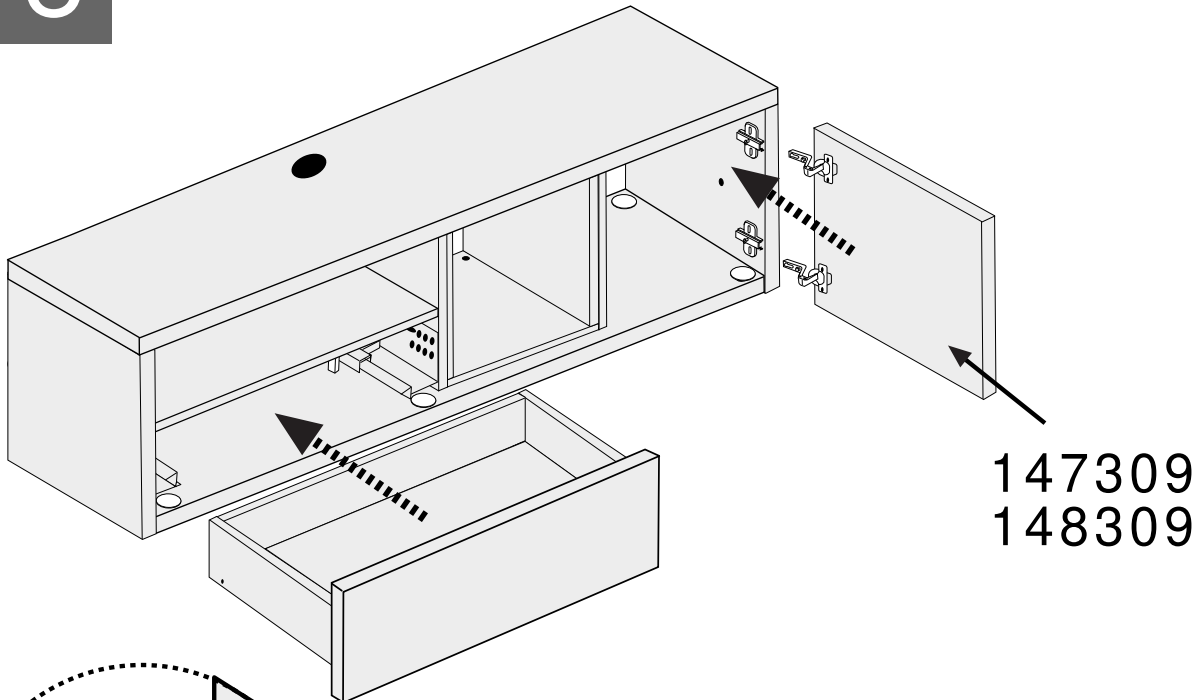

19

x1

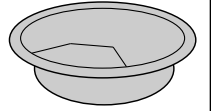

PC60N

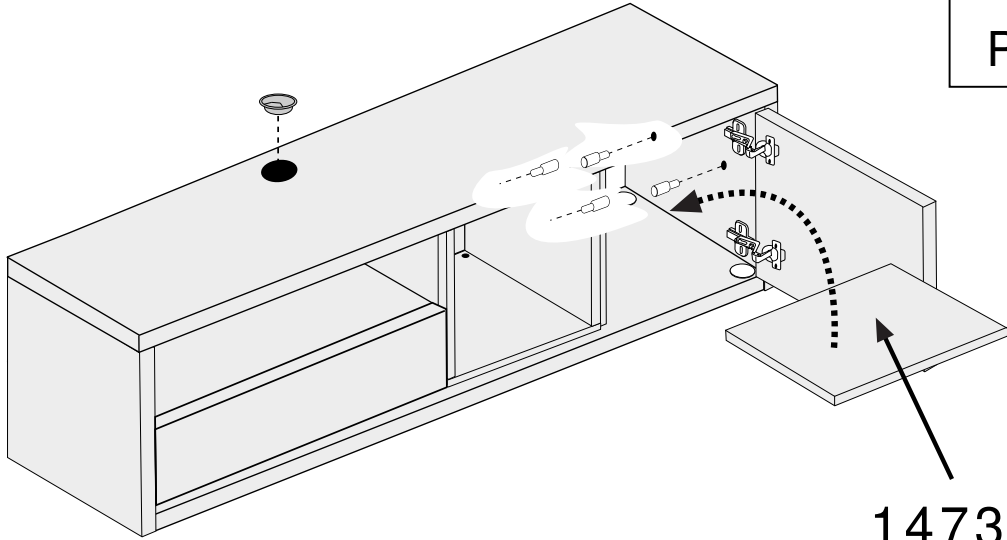

147308
148308

x4

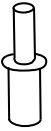

PE3

20

