



# Installation & Operation for Model 30573-0003 Mini Accumulator Tank

## MINI ACCUMULATOR TANK

### FEATURES

- Internal bladder
- Smoother flow
- Quieter water system
- Longer pump life
- Easily fitted to new or existing systems
- Compact size
- Quick-connect/disconnect port fittings
- Mounting point for optional pressure switch
- Food grade materials, NSF Standard 18 listed

### SPECIFICATIONS

**Tank:** Food-grade, nylon shell, butyl liner, stainless steel fasteners.

<b>Total internal volume:</b>	21.5 oz. (0.65L)
<b>Max operating pressure:</b>	125 psi (8.6 bar)
<b>Pre-charge pressure:</b>	10 psi (0.7 bar)
<b>Air fill valve:</b>	standard automotive style tire valve
<b>Dimensions:</b>	8.4" (214 mm) L X 4.7" (119 mm) W
<b>Weight:</b>	0.96 lbs. (0.44 kg)

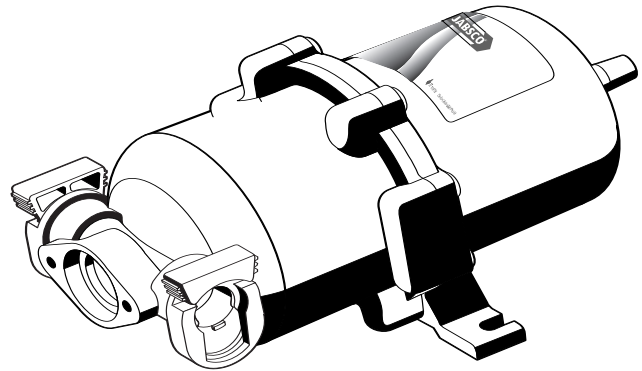

Model 30573-0003 Accumulator Tank

## IMPROVES MOST AUTOMATIC WATER SYSTEMS

This accumulator tank is intended for installation in any pumped water system controlled by a pressure switch, and may also be used with air-driven pumps. The tank can serve as a storage vessel as well as a pulsation dampener for pressurized fluid. The accumulator tank smoothes water flow and reduces on/off switch cycling of the pump by lessening the variation in pressure and flow between the pump and the system discharge points. The even flow of water gives better control of hot water temperature with systems using instant water heaters.

## PRE-CHARGE PRESSURE ADJUSTMENT

The accumulator tank is pre-charged at 10 psi (0.7 bar). If your pump's electric pump cut-in pressure is significantly different, you may adjust the tank pressure to better suit your particular installation.

To increase air pressure in tank, shut pump off, open a faucet to relieve system pressure, and adjust precharge pressure using ordinary tire gauge and tire pump at valve in end of tank. Pressure should be checked regularly. To check tank pressure: turn off power to water pump, open a faucet to relieve pressure. Check tank pressure, adjust if necessary. Close faucet and turn on power to pump. For best results, do not pressurize tank above 20 psi (1.4 bar).

## TYPICAL INSTALLATION

Disconnect power supply to pump. Open the faucet or appliance discharge valve. Tank installs anywhere in-line on discharge side of pump. Fasten hose to inlet/outlet fittings securely with hose clamps. Failure to do so may result in flooding and/or equipment damage. Restore water supply, then restore power supply. Allow water to flow through pump and out final discharge point in order to eliminate air from system. Tank may be mounted in any position. To remove the tank from the system, always disconnect power source to the pump, and open a faucet or appliance to safely vent water under pressure.

## SAFETY

If possible, use a safety relief valve set for 125 psi (8.6 bar) max., installed in-line on the pump discharge side. Use flexible braided hose to minimize noise and/or vibration. Hose should be rated for pressure levels expected of each system.

## REPLACEMENT PARTS

30654-1000 1/2" (13 mm) Straight Hose Barb  
 30649-1000 1/2" (13 mm) Threaded  
 All parts 2 per bag

## HOW THE PRESSURE ACCUMULATOR WORKS

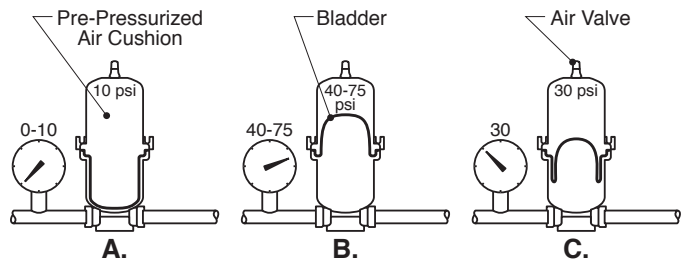

- Factory installed precharged air cushion.
- When pump starts, water enters the reservoir. At maximum pressure, system is filled. Pump shuts off.
- When water is demanded, pressure in the air chamber forces water into the system. Pump stays off until minimum pressure is reached, then pump starts and runs until cut-out pressure is reached.

**CAUTION** Do not overpressurize tank. Pressures over 125 psi (8.6 bar) may rupture tank and cause personal injury.

## DIMENSIONAL DRAWING (Inches/mm)

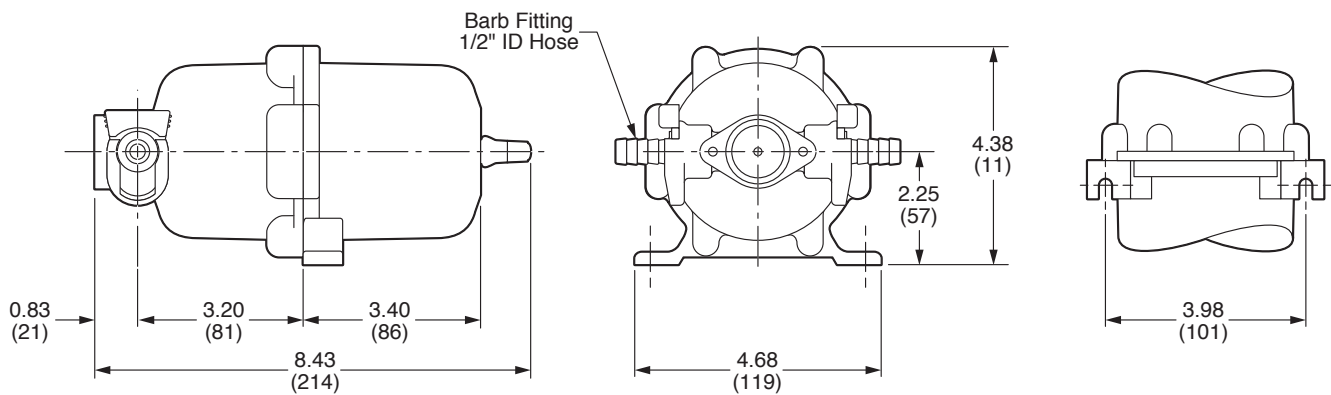

## RETURN PROCEDURE

Prior to returning any product to Jabsco, call customer service for an authorization number. This number must be written on the outside of the shipping package. Place a note inside the package with an explanation for return as well as the authorization number. Include your name, address and phone number.

## PRODUCT WARRANTY

Jabsco warrants this product to be free of defects in material and/or workmanship for a period of one year after purchase by the customer from Jabsco. During this one year warranty period, Jabsco will at its option, at no charge to the customer, repair or replace this product, if found defective, with a new or reconditioned product, but not to include costs of removal or installation. No product will be accepted for return without a return material authorization number. All return goods must be shipped with transportation charges prepaid. A complete copy of our warranty is available upon request.

Jabsco

[www.jabsco.com](http://www.jabsco.com)

**U.S.A.**  
 Flojet  
 Cape Ann Industrial Park  
 Gloucester, MA 01930  
 Tel: 978.281.0440  
 Fax: 978.283.2619

**UNITED KINGDOM**  
 Flojet  
 Bingley Road, Hoddesdon  
 Hertfordshire EN11 0BU  
 Tel: +44 (0) 1992 450145  
 Fax: +44 (0) 1992 467132

**CANADA**  
 Fluid Products Canada  
 55 Royal Road  
 Guelph, Ontario N1H 1T1  
 Tel: 519 821.1900  
 Fax: 519 821.2569

**JAPAN**  
 NHK Jabsco Company Ltd.  
 3-21-10, Shin-Yokohama  
 Kohoku-Ku, Yokohama, 222-0033  
 Tel: 045.475.8906  
 Fax: 045.477.1162

**GERMANY**  
 Jabsco GmbH  
 Oststrasse 28  
 22840 Norderstedt  
 Tel: +49-40-53 53 73 -0  
 Fax: +49-40-53 53 73 -11

**ITALY**  
 Jabsco Marine Italia  
 Via Tommaseo, 6  
 20059 Vimercate, Milano  
 Tel: +39 039 685 2323  
 Fax: +39 039 666 307