



# RAM MOUNTS

## RAM® Vibe-Safe™ Vibration Damper



**CLICK OR SCAN**  
TO VIEW ALL PRODUCTS

Patented & Pats Pend.  
[rammount.com/ip](http://rammount.com/ip)





# RAM® VIBE-SAFE™

AVAILABLE SKUS

Patented & Pats Pend.  
[rammount.com/ip](http://rammount.com/ip)



## RAM-HOL-UN7B-462

RAM® X-Grip® with Ball & Vibe-Safe™ Adapter



### RAM-B-176-A-UN7-462

RAM® X-Grip® Phone Mount with Vibe-Safe™ & Fork Stem Base - Short



### RAM-B-176-A-UN10-462

RAM® Large X-Grip® Phone Mount with Vibe-Safe™ & Fork Stem Base - Short



### RAM-B-176-A-PD4-462

RAM® XL Quick-Grip™ Phone Mount with Vibe-Safe™ & Fork Stem Base - Short

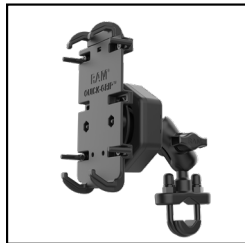

### RAM-B-149Z-A-PD4-462

RAM® Quick-Grip™ XL with Vibe-Safe™ & U-Bolt Base - Short



### RAM-B-149Z-A-UN7-462

RAM® X-Grip® Phone Mount with Vibe-Safe™ & U-Bolt Base - Short



### RAM-B-149Z-A-UN10-462

RAM® Large X-Grip® Phone Mount with Vibe-Safe™ & U-Bolt Base - Short



### RAM-149Z-UN7-462

RAM® X-Grip® Phone Mount with Vibe-Safe™ & U-Bolt Base - Medium



### RAM-149Z-UN10-462

RAM® Large X-Grip® Phone Mount with Vibe-Safe™ & U-Bolt Base - Medium



### RAM-B-174-UN7-462

RAM® X-Grip® Phone Mount with Vibe-Safe™ & Reservoir Base



### RAM-B-174-UN10-462

RAM® Large X-Grip® Phone Mount with Vibe-Safe™ & Reservoir Base

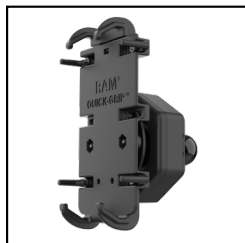

### RAM-HOL-PD4-462B

RAM® Quick-Grip™ XL with Vibe-Safe™ Adapter & Ball



### RAM-HOL-UN7-462-400

RAM® X-Grip® with Vibe-Safe™ & Small Tough-Claw™



### RAM-HOL-UN7B-462

RAM® X-Grip® with Ball & Vibe-Safe™ Adapter



### RAM-HOL-UN10-462-400

RAM® Large X-Grip® with Vibe-Safe™ & Small Tough-Claw™



### RAM-HOL-UN10B-462

RAM® Large X-Grip® with Ball & Vibe-Safe™ Adapter

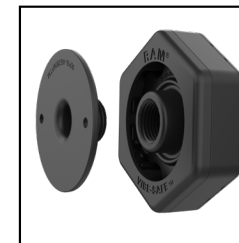

### RAP-462NPT

RAM® Vibe-Safe™ with NPT Adapter for 2-Hole Holders



### RAP-400-462NPT

RAM® Tough-Claw™ Small Clamp Base with Vibe-Safe™ Adapter



# RAM® VIBE-SAFE™

COMPATIBILITY & CUSTOMIZATION

Patented & Pats Pend.  
[rammount.com/ip](http://rammount.com/ip)

## BASE OPTIONS



### RAM® Tough-Claw™ with Pin-Lock™ Pattern

Quick and easy tool-less installation or removal. Offers the most low-profile mounting option.



### RAM® Diamond Ball Base - B Size

Features a two-hole AMPS hole pattern that is compatible with RAM® double-socket arms.



### RAM® Motorcycle Fork Stem Ball Base - B Size

Features a cylindrical bore wall fitting made of powder-coated marine-grade aluminum, featuring a 1" RAM® rubber ball.

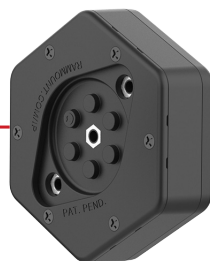

## RAM® X-GRIP® COMPATIBLE



### RAM® Vibe-Safe™ with Pin-Lock™ Pattern

Compatible with RAM® X-Grip® with female Pin-Lock™ pattern.



Existing RAM X-Grip® Mounts and X-Grip® with ball cannot upgrade to RAM® Vibe-Safe™



### Pin-Lock™ RAM® X-Grip®

Two sizes to accommodate all phone sizes with or without cases.

## RAM® QUICK-GRIP™ COMPATIBLE

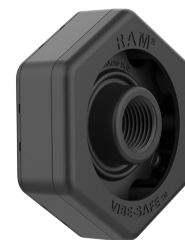

### RAM® Vibe-Safe™ with NPT Adapter

Compatible with most 2-hole holders.

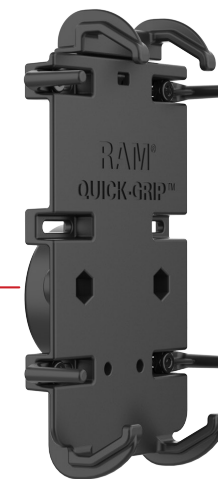
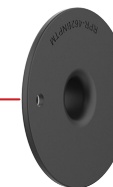

### RAM® Quick-Grip™

Adjustable universal phone mount that allows easy insertion and removal of your device with one hand.



# RAM® VIBE-SAFE™

DIMENSIONS

Patented & Pats Pend.  
[rammount.com/ip](http://rammount.com/ip)

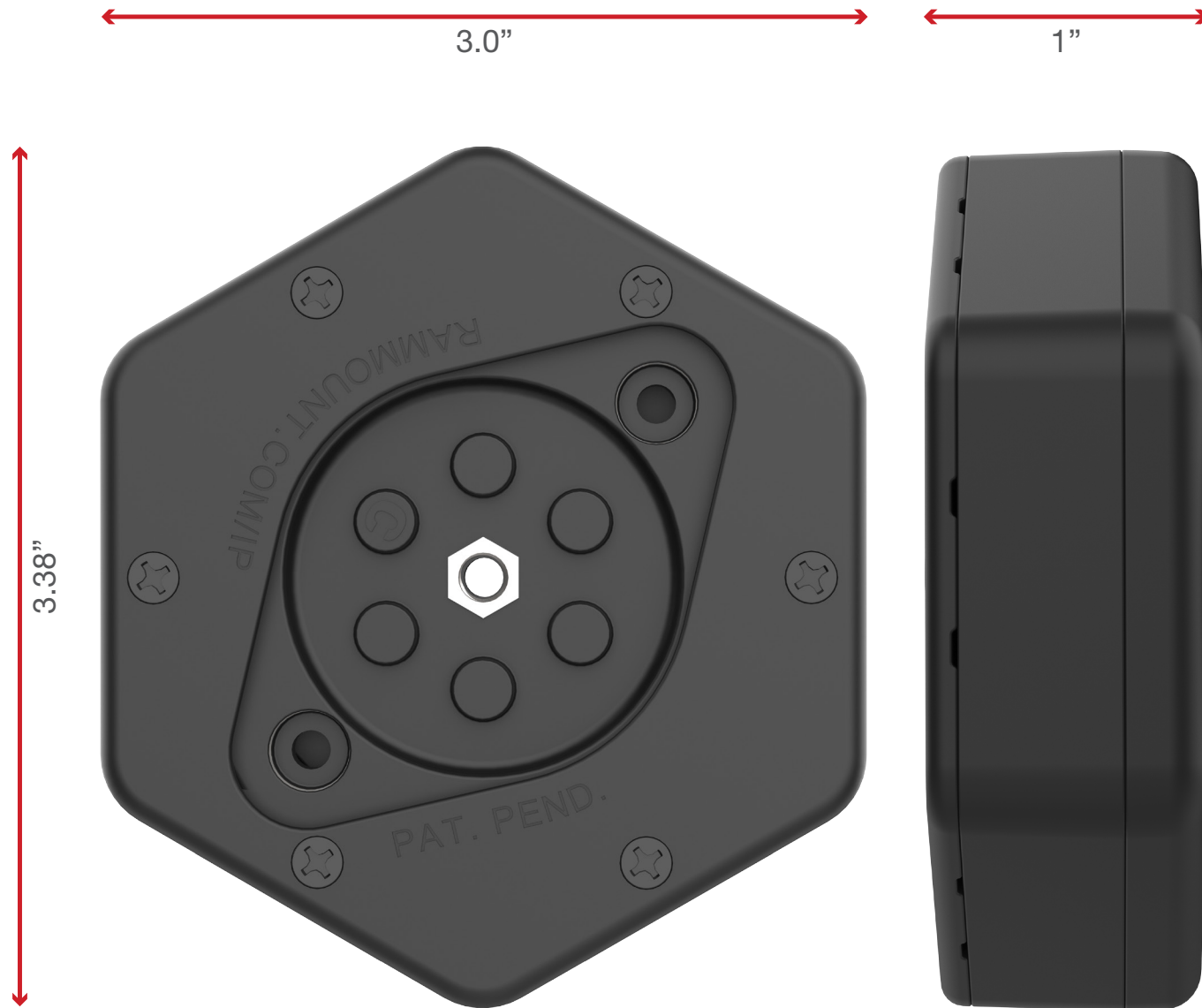



# RAM® VIBE-SAFE™

FEATURES & BENEFITS

Patented & Pats Pend.  
[rammount.com/ip](http://rammount.com/ip)

## RAM® MOUNTS COMPATIBLE™

Compatible with all styles of RAM® phone holders



## DAMPENS WIDE RANGE OF VIBRATION FREQUENCIES

Supports all bike styles, idling or at high speeds

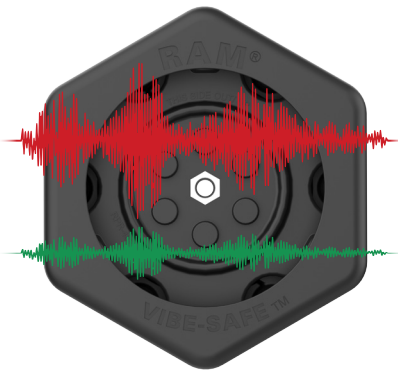

## NPT THREAD CONNECTION

Allows rotation between portrait and landscape while remaining secure



## UNIQUE DESIGN

Built with all industries in mind



 A reduction in vibration does not guarantee full protection of device. External immeasurable factors may cause damage to phones, cameras, and other devices while mounted in the RAM® Vibe-Safe™. National Products, Inc does not assume responsibility or liability for any such personal injury, death or property damage. RAM® Mounts lifetime warranty is limited to RAM® Mounts and components. The warranty does not include any device mounted or attached to a RAM® Mount, such as a phone, GPS, camera, computer or other device.

