



SHENZHEN YARUI TESTING CO., LTD.

No.1107-1109, Weidonglong Technology Building, Meilong Avenue, Qinghu Longhua District ,
Shenzhen 518109, Guangdong, China
Tel : +86-755-27912080 Fax: +86-755-27916936

EMC TEST REPORT

Product name: Headlamp

Trademark: Fenix

Model No.: HM65R(ENGLAND), HM50R V2.0, HM65R(FINLAND RED),
HP16R, HP25R V2.0, HP30R V2.0

Test Standards: **EN 55015: 2013+A1: 2015**
EN 61547: 2009
EN 61000-3-2: 2014
EN 61000-3-3: 2013+A1:2019

Applicant: SHENZHEN LANGHENG ELECTRONIC CO., LTD.

Address of applicant: 8/F., 2nd Building, DongFangMing Industrial Center, 33rd District,
Bao'an, Shenzhen 518133, China.

Date of Test: Jul.24, 2020 – Jul.30, 2020

Date of issue: Jul. 30, 2020

Report No.: YRT202007381E

Test result	Pass *
--------------------------	--------

* In the configuration tested, the EUT complied with the standards specified above



The CE mark as shown above can be used, under the responsibility of the manufacturer, after completion of an EC Declaration of Conformity and compliance with all relevant EC Directives. The protection requirements with respect to electromagnetic compatibility contained in Directive 2014/30/EU are considered.

TABLE OF CONTENT

	Page
Test Report Declaration	
1. GENERAL INFORMATION.....	5
1.1. Description of Device (EUT).....	5
1.2. Tested System Details.....	5
1.3. Test Uncertainty.....	5
1.4. Test Facility.....	6
2. TEST INSTRUMENT USED.....	7
3. CONDUCTED EMISSION AT THE MAINS TERMINALS TEST.....	10
3.1. Block Diagram Of Test Setup.....	10
3.2. Test Standard.....	10
3.3. Power Line Conducted Emission Limit.....	10
3.4. EUT Configuration on Test.....	10
3.5. Operating Condition of EUT.....	10
3.6. Test Procedure.....	11
3.7. Test Result.....	11
4. MAGNETIC EMISSION TEST.....	12
4.1. Block Diagram Of Test Setup.....	12
4.2. Test Standard.....	12
4.3. Power Line Conducted Emission Limit.....	12
4.4. EUT Configuration on Test.....	12
4.5. Operating Condition of EUT.....	12
4.6. Test Procedure.....	13
4.7. Test Result.....	13
5. RADIATION EMISSION TEST.....	14
5.1. Block Diagram of Test Setup.....	14
5.2. Test Standard.....	14
5.3. Radiation Limit.....	14
5.4. EUT Configuration on Test.....	14
5.5. Operating Condition of EUT.....	15
5.6. Test Procedure.....	15
5.7. Test Result.....	15
6. HARMONIC CURRENT EMISSION TEST.....	18
6.1. Block Diagram of Test Setup.....	18
6.2. Test Standard.....	18
6.3. Operating Condition of EUT.....	18
6.4. Test Procedure.....	18
6.5. Test Results.....	18
7. VOLTAGE FLUCTUATIONS & FLICKER TEST.....	19
7.1. Block Diagram of Test Setup.....	19
7.2. Test Standard.....	19
7.3. Operating Condition of EUT.....	19
7.4. Test Procedure.....	19
7.5. Test Results.....	19
8. ELECTROSTATIC DISCHARGE IMMUNITY TEST.....	20
8.1. Block Diagram of Test Setup.....	20
8.2. Test Standard.....	20
8.3. Severity Levels and Performance Criterion.....	20
8.4. EUT Configuration.....	21
8.5. Operating Condition of EUT.....	22
8.6. Test Procedure.....	22

SHENZHEN YARUI TESTING CO., LTD.

Address: No.1107-1109, Weidonglong Technology Building, Meilong Avenue, Qinghu Longhua District ,

Shenzhen 518109, Guangdong, China

Tel.: +86-755-27912080 Fax.: +86-755-27916936 Website: www.yarui-lab.com

8.7.	Test Results.....	22
9.	RF FIELD STRENGTH SUSCEPTIBILITY TEST	24
9.1.	Block Diagram of Test Setup	24
9.2.	Test Standard	24
9.3.	Severity Levels and Performance Criterion	24
9.4.	EUT Configuration on Test.....	25
9.5.	Operating Condition of EUT	25
9.6.	Test Procedure	26
9.7.	Test Results.....	26
10.	ELECTRICAL FAST TRANSIENT/BURST IMMUNITY TEST	27
10.1.	Block Diagram of EUT Test Setup	27
10.2.	Test Standard	27
10.3.	Severity Levels and Performance Criterion	27
10.4.	EUT Configuration on Test.....	28
10.5.	Operating Condition of EUT	28
10.6.	Test Procedure	28
10.7.	Test Results.....	28
11.	SURGE TEST	29
11.1.	Block Diagram of EUT Test Setup	29
11.2.	Test Standard	29
11.3.	Severity Levels and Performance Criterion	29
11.4.	EUT Configuration on Test.....	30
11.5.	Operating Condition of EUT	30
11.6.	Test Procedure	30
11.7.	Test Result.....	30
12.	INJECTED CURRENTS SUSCEPTIBILITY TEST	31
12.1.	Block Diagram of EUT Test Setup	31
12.2.	Test Standard	31
12.3.	Severity Levels and Performance Criterion	31
12.4.	EUT Configuration on Test.....	32
12.5.	Operating Condition of EUT	32
12.6.	Test Procedure	32
12.7.	Test Result.....	33
13.	MAGNETIC FIELD IMMUNITY TEST	34
13.1.	Block Diagram of Test Setup	34
13.2.	Test Standard	34
13.3.	Severity Levels and Performance Criterion	34
13.4.	EUT Configuration on Test.....	35
13.5.	Operating Condition of EUT	35
13.6.	Test Procedure	35
13.7.	Test Results.....	35
14.	VOLTAGE DIPS AND INTERRUPTIONS TEST	37
14.1.	Block Diagram of EUT Test Setup	37
14.2.	Test Standard	37
14.3.	Severity Levels and Performance Criterion	37
14.4.	EUT Configuration on Test.....	38
14.5.	Operating Condition of EUT	38
14.6.	Test Procedure	38
14.7.	Test Result.....	38
15.	EUT TEST PHOTOGRAPHS	39
16.	EUT PHOTOGRAPHS	40

SHENZHEN YARUI TESTING CO., LTD.

Address: No.1107-1109, Weidonglong Technology Building, Meilong Avenue, Qinghu Longhua District ,

Shenzhen 518109, Guangdong, China

Tel.: +86-755-27912080 Fax.: +86-755-27916936 Website: www.yarui-lab.com

Applicant : SHENZHEN LANGHENG ELECTRONIC CO., LTD.
Address : 8/F., 2nd Building, DongFangMing Industrial Center, 33rd District,
Bao'an, Shenzhen 518133, China.
Manufacturer : SHENZHEN LANGHENG ELECTRONIC CO., LTD.
Address : 8/F., 2nd Building, DongFangMing Industrial Center, 33rd District,
Bao'an, Shenzhen 518133, China.
EUT : Headlamp
Model Number : HM65R(ENGLAND), HM50R V2.0, HM65R(FINLAND RED), HP16R,
HP25R V2.0, HP30R V2.0
Trademark: : Fenix
Test Result: : The equipment under test was found to be compliance with the
requirements of the standards applied.

Test Procedure Used:

EMI : **EN 55015:2013+A1:2015**
EN 61000-3-2:2014, EN 61000-3-3: 2013+A1:2019

EMS : **EN 61547:2009**
EN 61000-4-2:2009, EN 61000-4-3:2006+A1:2008+A2:2010,
EN 61000-4-4:2012, EN 61000-4-5:2014+A1:2017,
EN 61000-4-6:2014, EN 61000-4-8:2010,
EN 61000-4-11:2004+A1:2017

Prepared by(Engineer): David Zhong

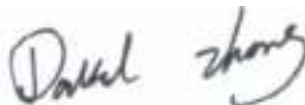

Reviewer(Supervisor): Tony Wang

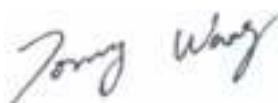

Approved(Manager): Lily Yu



This test report is based on a single evaluation of one sample of above mentioned products. It is not permitted to be duplicated in extracts without written approval of SHENZHEN YARUI TESTING CO., LTD.

SHENZHEN YARUI TESTING CO., LTD.

Address: No.1107-1109, Weidonglong Technology Building, Meilong Avenue, Qinghu Longhua District,
Shenzhen 518109, Guangdong, China

Tel.: +86-755-27912080 Fax.: +86-755-27916936 Website: www.yarui-lab.com

1. GENERAL INFORMATION

1.1. Description of Device (EUT)

EUT : Headlamp

Trademark : Fenix

Model Number : HM65R(ENGLAND), HM50R V2.0, HM65R(FINLAND RED),
HP16R, HP25R V2.0, HP30R V2.0

Model Difference : All the models are similar, the model HM65R(ENGLAND) is
selected for tested.

Power Supply : DC 3.6V

1.2. Tested System Details

None.

1.3. Test Uncertainty

Conducted Emission : ± 2.66 dB
Uncertainty

Radiated Emission Uncertainty : ± 4.26 dB

SHENZHEN YARUI TESTING CO., LTD.

Address: No.1107-1109, Weidonglong Technology Building, Meilong Avenue, Qinghu Longhua District ,
Shenzhen 518109, Guangdong, China

Tel.: +86-755-27912080 Fax.: +86-755-27916936 Website: www.yarui-lab.com



1.4. Test Facility

Site Description

Name of Firm : SHENZHEN YARUI TESTING CO., LTD.
Site Location : NO. 101, Yousong Road, Longhua District, Shenzhen,
China
Lab Qualifications : Certificated by Industry Canada
Registration No.: 12655A

Certificated by FCC, USA
Registration No.: 187086

SHENZHEN YARUI TESTING CO., LTD.

Address: No.1107-1109, Weidonglong Technology Building, Meilong Avenue, Qinghu Longhua District ,
Shenzhen 518109, Guangdong, China
Tel.: +86-755-27912080 Fax.: +86-755-27916936 Website: www.yarui-lab.com

2. TEST INSTRUMENT USED

For Conducted Emission at the mains terminals Test

Conducted Emission Test (A --- site)					
Equipment	Manufacturer	Model#	Serial#	Last Cal.	Next Cal.
843 Shielded Room	ChengYu	843 Room	843	Dec. 27, 2019	Dec. 26, 2020
EMI Receiver	R&S	ESCI	101421	Dec. 27, 2019	Dec. 26, 2020
LISN	Schwarzbeck	NSLK8127	8127739	Dec. 27, 2019	Dec. 26, 2020
Attenuator	R&S	ESH3-Z2	YRT021E	Dec. 27, 2019	Dec. 26, 2020
843 Cable 1#	FUJIKURA	843C1#	001	Dec. 27, 2019	Dec. 26, 2020

For Magnetic Emission Test

Conducted Emission Test (A --- site)					
Equipment	Manufacturer	Model#	Serial#	Last Cal.	Next Cal.
843 Shielded Room	ChengYu	843 Room	843	Dec. 27, 2019	Dec. 26, 2020
EMI Receiver	R&S	ESCI	101421	Dec. 27, 2019	Dec. 26, 2020
Three-loop antenna	DAZE	ZN30401	13017	Dec. 27, 2019	Dec. 26, 2020
Attenuator	R&S	ESH3-Z2	YRT021E	Dec. 27, 2019	Dec. 26, 2020
843 Cable 2#	FUJIKURA	843C1#	002	Dec. 27, 2019	Dec. 26, 2020

For Radiated Emission Test

Radiation Emission Test (966 chamber)					
Equipment	Manufacturer	Model#	Serial#	Last Cal.	Next Cal.
966 chamber	ChengYu	966 Room	966	Dec. 27, 2019	Dec. 26, 2020
Spectrum Analyzer	Agilent	E4407B	MY45109572	Dec. 27, 2019	Dec. 26, 2020
Amplifier	Schwarzbeck	BBV9743	9743-119	Dec. 27, 2019	Dec. 26, 2020
Amplifier	Schwarzbeck	BBV9718	9718-270	Dec. 27, 2019	Dec. 26, 2020
Log-periodic Antenna	Schwarzbeck	VULB9160	VULB9160-3369	Dec. 27, 2019	Dec. 26, 2020
EMI Receiver	R&S	ESCI	101421	Dec. 27, 2019	Dec. 26, 2020
Horn Antenna	Schwarzbeck	BBHA9120D	9120D-1275	Dec. 27, 2019	Dec. 26, 2020
966 Cable 1#	CHENGYU	966	004	Dec. 27, 2019	Dec. 26, 2020
966 Cable 2#	CHENGYU	966	003	Dec. 27, 2019	Dec. 26, 2020

SHENZHEN YARUI TESTING CO., LTD.

For Harmonic & Flicker Test

For Harmonic / Flicker Test (A --- site)					
Equipment	Manufacturer	Model#	Serial#	Last Cal.	Next Cal.
Harmonic / Flicker Analyzer	KIKUSUI	KHA1000	VA002445	Dec. 27, 2019	Dec. 26, 2020
AC Power Supply	KIKUSUI	PCR4000M	UK001879	Dec. 27, 2019	Dec. 26, 2020
Line Impedance network	KIKUSUI	LIN1020JF	UL001611	Dec. 27, 2019	Dec. 26, 2020

For Electrostatic Discharge Immunity Test

For Electrostatic Discharge Immunity Test (A --- site)					
Equipment	Manufacturer	Model#	Serial#	Last Cal.	Next Cal.
ESD Tester	KIKUSUI	KES4201A	UH002321	Dec. 27, 2019	Dec. 26, 2020

For RF Field Strength Susceptibility Test(SMQ)

For RF Field Strength Susceptibility Test (SMQ --- site)					
Equipment	Manufacturer	Model#	Serial#	Last Cal.	Next Cal.
Signal Generator	HP	8648A	3625U00573	Dec. 27, 2019	Dec. 26, 2020
Amplifier	A&R	500A100	17034	Dec. 27, 2019	Dec. 26, 2020
Amplifier	A&R	100W/1000M1	17028	Dec. 27, 2019	Dec. 26, 2020
Audio Analyzer (20Hz~1GHz)	Panasonic	2023B	202301/428	Dec. 27, 2019	Dec. 26, 2020
Isotropic Field Probe	A&R	FP2000	16755	Dec. 27, 2019	Dec. 26, 2020
Antenna	EMCO	3108	9507-2534	Dec. 27, 2019	Dec. 26, 2020
Log-periodic Antenna	A&R	AT1080	16812	Dec. 27, 2019	Dec. 26, 2020

For Electrical Fast Transient /Burst Immunity Test

For Electrical Fast Transient/Burst Immunity Test (A --- site)					
Equipment	Manufacturer	Model#	Serial#	Last Cal.	Next Cal.
Burst Tester	Prima	EFT61004AG	PR14054467	Dec. 27, 2019	Dec. 26, 2020
Coupling Clamp	Prima	EFT61004AG	YRT009E	Dec. 27, 2019	Dec. 26, 2020

SHENZHEN YARUI TESTING CO., LTD.

Address: No.1107-1109, Weidonglong Technology Building, Meilong Avenue, Qinghu Longhua District ,
Shenzhen 518109, Guangdong, China
Tel.: +86-755-27912080 Fax.: +86-755-27916936 Website: www.yarui-lab.com

For Surge Test

For Surge Test (A --- site)					
Equipment	Manufacturer	Model#	Serial#	Last Cal.	Next Cal.
Surge Tester	Prima	SUG61005BX	PR12045446	Dec. 27, 2019	Dec. 26, 2020

For Injected Currents Susceptibility Test

For Injected Currents Susceptibility Test (A --- site)					
Equipment	Manufacturer	Model#	Serial#	Last Cal.	Next Cal.
C/S Test System	SCHLODER	CDG600	126B1281	Dec. 27, 2019	Dec. 26, 2020
CDN	SCHLODER	CDN-M2+3	A2210320/20 15	Dec. 27, 2019	Dec. 26, 2020
Injection Clamp	SCHLOBER	EMCL-20	132A1214/20 15	Dec. 27, 2019	Dec. 26, 2020

For Magnetic Field Immunity Test

For Magnetic Field Immunity Test (A --- site)					
Equipment	Manufacturer	Model#	Serial#	Last Cal.	Next Cal.
Magnetic field generator	HTEC	HPFMF	15701	Dec. 27, 2019	Dec. 26, 2020

For Voltage Dips Interruptions Test

For Voltage Dips Interruptions Test (A --- site)					
Equipment	Manufacturer	Model#	Serial#	Last Cal.	Next Cal.
Dips Tester	Prima	DRP61011AG	PR14086284	Dec. 27, 2019	Dec. 26, 2020

SHENZHEN YARUI TESTING CO., LTD.

Address: No.1107-1109, Weidonglong Technology Building, Meilong Avenue, Qinghu Longhua District ,
Shenzhen 518109, Guangdong, China
Tel.: +86-755-27912080 Fax.: +86-755-27916936 Website: www.yarui-lab.com

3. CONDUCTED EMISSION AT THE MAINS TERMINALS TEST

3.1. Block Diagram Of Test Setup

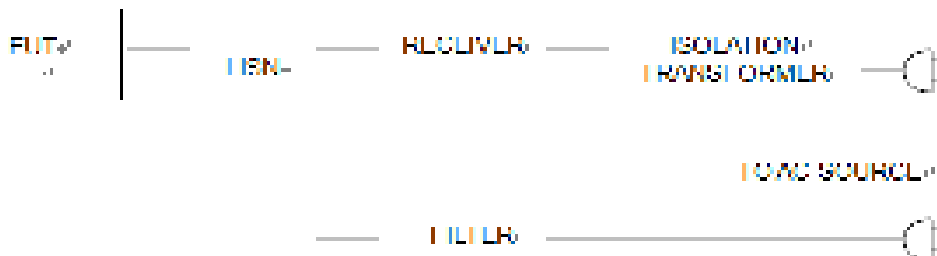

3.2. Test Standard

EN 55015:2013+A1:2015

3.3. Power Line Conducted Emission Limit

Frequency MHz	Limits dB(μV)	
	Quasi-peak Level	Average Level
0.009 ~ 0.05	110	N/A
0.05 ~ 0.15	90 ~ 80*	N/A
0.15 ~ 0.50	66 ~ 56*	56 ~ 46*
0.50 ~ 5.00	56	46
5.00 ~ 30.00	60	50

Notes: 1. *Decreasing linearly with logarithm of frequency.
2. The lower limit shall apply at the transition frequencies.

3.4. EUT Configuration on Test

The following equipments are installed on conducted emission test to meet EN55015 requirement and operating in a manner which tends to maximize its emission characteristics in a normal application.

3.5. Operating Condition of EUT

- 3.5.1 Setup the EUT and simulators as shown in Section 3.1.
- 3.5.2 Turn on the power of all equipments.
- 3.5.3 Let the EUT work in test modes and test it.

SHENZHEN YARUI TESTING CO., LTD.

Address: No.1107-1109, Weidonglong Technology Building, Meilong Avenue, Qinghu Longhua District ,
Shenzhen 518109, Guangdong, China
Tel.: +86-755-27912080 Fax.: +86-755-27916936 Website: www.yarui-lab.com

3.6. Test Procedure

The EUT is put on the ground and connected to the AC mains through a Artificial Mains Network (AMN). This provided a 50ohm coupling impedance for the tested equipments. Both sides of AC line are checked to find out the maximum conducted emission levels according to the **EN55015** regulations during conducted emission test.

The bandwidth of the test receiver (R&S Test Receiver ESCI) is set at 10KHz.

The frequency range from 150 KHz to 30 MHz is investigated.

3.7. Test Result

The product's power provide by DC, no requirement for this item.

SHENZHEN YARUI TESTING CO., LTD.

Address: No.1107-1109, Weidonglong Technology Building, Meilong Avenue, Qinghu Longhua District ,
Shenzhen 518109, Guangdong, China
Tel.: +86-755-27912080 Fax.: +86-755-27916936 Website: www.yarui-lab.com

4. MAGNETIC EMISSION TEST

4.1. Block Diagram Of Test Setup

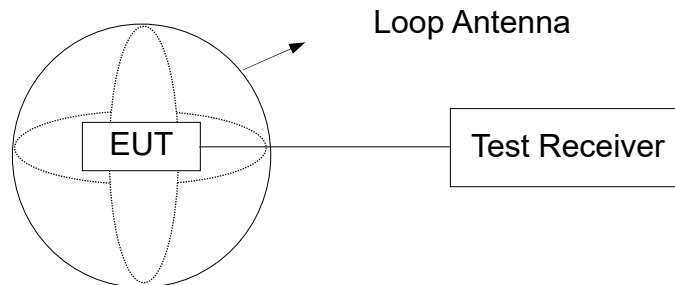

4.2. Test Standard

EN 55015:2013+A1:2015

4.3. Power Line Conducted Emission Limit

Frequency MHz	Limits dB(μ A)
	Quasi-peak Level
0.009 ~ 0.07	88
0.07 ~ 0.15	88 ~ 58*
0.15 ~ 0.50	58 ~ 22*
0.50 ~ 5.00	22

Notes: 1. *Decreasing linearly with logarithm of frequency.
2. The lower limit shall apply at the transition frequencies.

4.4. EUT Configuration on Test

The following equipments are installed on conducted emission test to meet EN55015 requirement and operating in a manner which tends to maximize its emission characteristics in a normal application.

4.5. Operating Condition of EUT

3.5.1 Setup the EUT and simulators as shown in Section 3.1.

3.5.2 Turn on the power of all equipments.

3.5.3 Let the EUT work in test modes and test it.

SHENZHEN YARUI TESTING CO., LTD.

Address: No.1107-1109, Weidonglong Technology Building, Meilong Avenue, Qinghu Longhua District ,
Shenzhen 518109, Guangdong, China

Tel.: +86-755-27912080 Fax.: +86-755-27916936 Website: www.yarui-lab.com

4.6. Test Procedure

The EUT is placed on a wood table in the center of a loop antenna. The induced current in the loop antenna is measured by means of a current probe and the test receiver. Three field components is checked by means of a coax switch.

The frequency range from 9KHz to 30MHz is investigated. The receiver is measured with the quasi-peak detector. For frequency band 9KHz to 150KHz, the bandwidth of the field strength meter (R&S Test Receiver ESCI) is set at 200Hz. For frequency band 150KHz to 30MHz , the bandwidth is set at 10KHz.

4.7. Test Result

PASS

SHENZHEN YARUI TESTING CO., LTD.

Address: No.1107-1109, Weidonglong Technology Building, Meilong Avenue, Qinghu Longhua District ,
Shenzhen 518109, Guangdong, China

Tel.: +86-755-27912080 Fax.: +86-755-27916936 Website: www.yarui-lab.com

5. RADIATION EMISSION TEST

5.1. Block Diagram of Test Setup

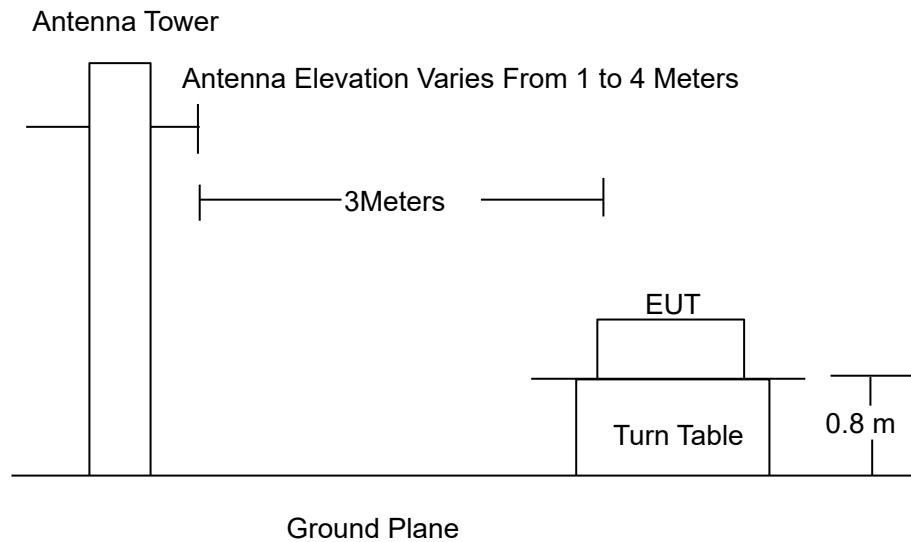

5.2. Test Standard

EN 55015:2013+A1:2015

5.3. Radiation Limit

Frequency MHz	Distance (Meters)	Field Strengths Limits dB(μ V)/m
30 ~ 230	3	40.0
230 ~ 300	3	47.0

Remark:

- (1) Emission level (dB(μ V)/m) = 20 log Emission level (μ V/m)
- (2) The smaller limit shall apply at the cross point between two frequency bands.
- (3) Distance refers to the distance in meters between the measuring instrument, antenna and the closed point of any part of the device or system.

5.4. EUT Configuration on Test

The EN55015 regulations test method must be used to find the maximum emission during radiated emission test.
The configuration of EUT is the same as used in conducted emission test.
Please refer to Section 2.2.

SHENZHEN YARUI TESTING CO., LTD.

Address: No.1107-1109, Weidonglong Technology Building, Meilong Avenue, Qinghu Longhua District ,
Shenzhen 518109, Guangdong, China
Tel.: +86-755-27912080 Fax.: +86-755-27916936 Website: www.yarui-lab.com

5.5. Operating Condition of EUT

Same as conducted emission test, which is listed in Section 2.2 except the test set up replaced as Section 4.1.

5.6. Test Procedure

The EUT and its simulators are placed on a turned table that is 0.8 meter above the ground. The turned table can rotate 360 degrees to determine the position of the maximum emission level. The EUT is set 3 meters away from the receiving antenna that is mounted on the antenna tower. The antenna can move up and down between 1 meter and 4 meters to find out the maximum emission level. Broadband antenna (calibrated biconical and log periodical antenna) is used as receiving antenna. Both horizontal and vertical polarization of the antenna is set on test. In order to find the maximum emission levels, the interface cable must be manipulated according to EN55015 on radiated emission test.

The bandwidth setting on the field strength meter (R&S Test Receiver ESCI) is set at 120KHz.

The frequency range from 30MHz to 1000MHz is checked.

5.7. Test Result

PASS

Please refer to the following page.

SHENZHEN YARUI TESTING CO., LTD.

Address: No.1107-1109, Weidonglong Technology Building, Meilong Avenue, Qinghu Longhua District ,

Shenzhen 518109, Guangdong, China

Tel.: +86-755-27912080 Fax.: +86-755-27916936 Website: www.yarui-lab.com

Radiation Emission Test Data			
Temperature:	24.5 °C	Relative Humidity:	54%
Pressure:	1009hPa	Phase :	Horizontal
Test Voltage :	DC 3.6V	Test Mode:	ON Mode

No. No.	Freq MHz	Reading Level dBuV	Correct Factor dB	Measure- ment dBuV/m	Limit dB/	Margin dB	Detector	Antenna Height cm	Table Degree degree	Comment
1	35.9151	28.42	-15.22	13.20	40.00	-26.80	QP			
2	49.1530	27.36	-13.64	13.72	40.00	-26.28	QP			
3	71.7594	35.86	-18.24	17.62	40.00	-22.38	QP			
4 *	95.9691	36.48	-16.49	19.97	40.00	-20.03	QP			
5	106.2232	36.22	-16.38	19.84	40.00	-20.16	QP			
6	183.9486	36.04	-16.92	19.12	40.00	-20.88	QP			

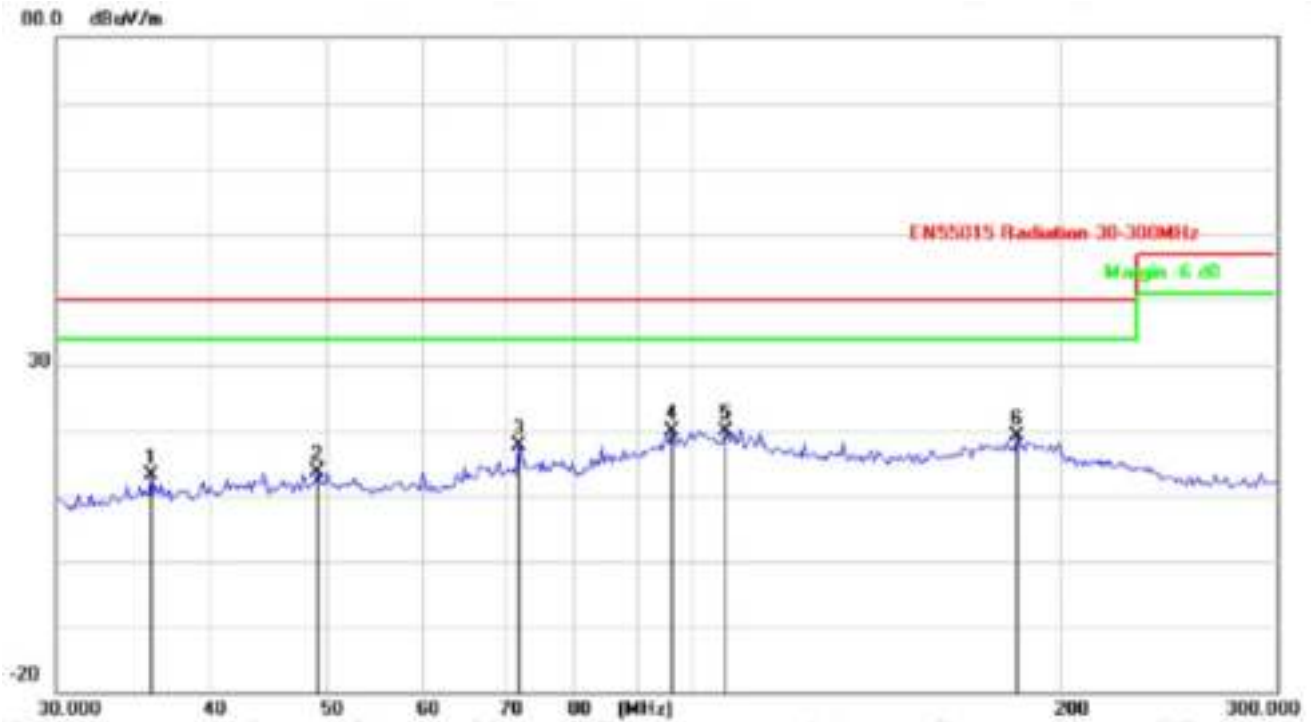

SHENZHEN YARUI TESTING CO., LTD.

Address: No.1107-1109, Weidonglong Technology Building, Meilong Avenue, Qinghu Longhua District ,
Shenzhen 518109, Guangdong, China
Tel.: +86-755-27912080 Fax.: +86-755-27916936 Website: www.yarui-lab.com

Radiation Emission Test Data			
Temperature:	24.5 °C	Relative Humidity:	54%
Pressure:	1009hPa	Phase :	Vertical
Test Voltage :	DC 3.6V	Test Mode:	ON Mode

No. tk.	Freq. MHz	Reading Level dBuV	Correct Factor dB	Measurement dBuV/m	Limit dB/	Margin dB	Detector	Antenna Height cm	Table Degree degree	Comment
1	44.2036	36.18	-14.11	22.07	40.00	-17.93	QP			
2	59.9408	30.79	-14.73	16.06	40.00	-23.94	QP			
3	71.7594	32.07	-11.89	20.18	40.00	-19.82	QP			
4	83.9489	30.05	-10.91	19.14	40.00	-20.86	QP			
5 *	107.7039	30.74	-8.54	22.20	40.00	-17.80	QP			
6	176.4657	28.24	-9.42	18.82	40.00	-21.18	QP			

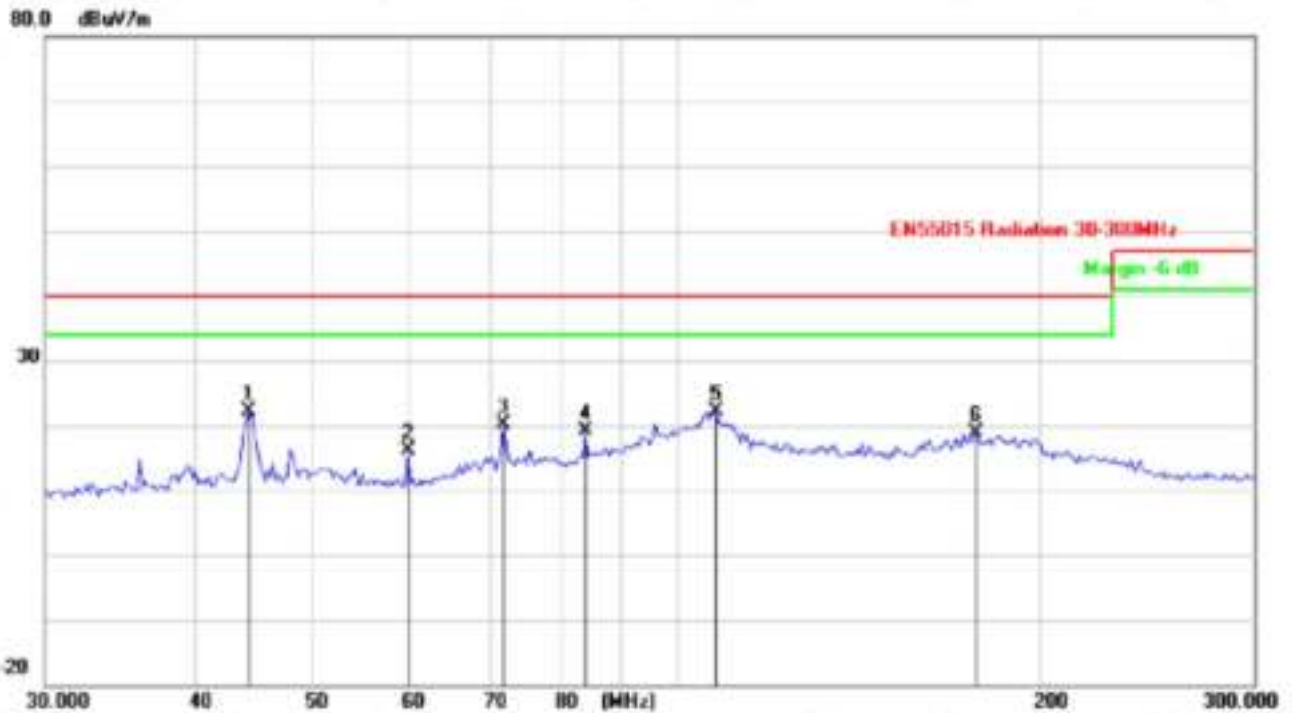

SHENZHEN YARUI TESTING CO., LTD.

Address: No.1107-1109, Weidonglong Technology Building, Meilong Avenue, Qinghu Longhua District ,
Shenzhen 518109, Guangdong, China
Tel.: +86-755-27912080 Fax.: +86-755-27916936 Website: www.yarui-lab.com

6. HARMONIC CURRENT EMISSION TEST

6.1. Block Diagram of Test Setup

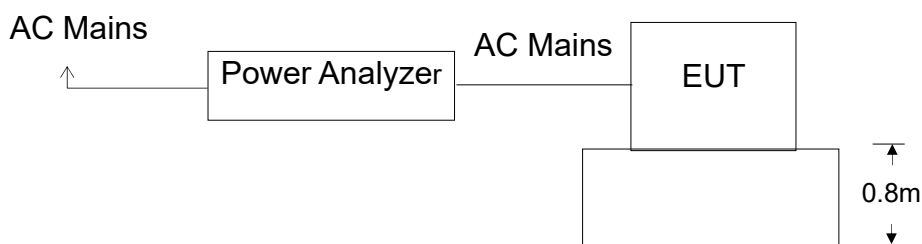

6.2. Test Standard

EN 61000-3-2:2014

6.3. Operating Condition of EUT

- 5.1.1 Setup the EUT as shown in Section 5.1.
- 5.1.2 Turn on the power of all equipments.
- 5.1.3 Let the EUT work in test mode and test it.

6.4. Test Procedure

The power cord of the EUT is connected to the output of the test system. Turn on the power of the EUT and use the test system to test the harmonic current level.

6.5. Test Results

PASS

Please refer to the following page.

There is no need for Harmonic current test to be performed on this product (rated power is less than 75 W) in accordance with EN 61000-3-2.

For further details, please refer to Clause 7 of EN 61000-3-2 which states:

“For the following categories of equipment, limits are not specified in this standard:

- equipment with a rated power of 75 W or less, other than lighting equipment.”

SHENZHEN YARUI TESTING CO., LTD.

Address: No.1107-1109, Weidonglong Technology Building, Meilong Avenue, Qinghu Longhua District,
Shenzhen 518109, Guangdong, China
Tel.: +86-755-27912080 Fax.: +86-755-27916936 Website: www.yarui-lab.com

7. VOLTAGE FLUCTUATIONS & FLICKER TEST

7.1. Block Diagram of Test Setup

Same as Section 6.1..

7.2. Test Standard

EN 61000-3-3: 2013+A1:2019

7.3. Operating Condition of EUT

Same as Section 5.3.. The power cord of the EUT is connected to the output of the test system. Turn on the power of the EUT and use the test system to test the harmonic current level.

Flicker Test Limit

Test items	Limits
Pst	1.0
dc	3.3%
dmax	4.0%
dt	Not exceed 3.3% for 500ms

7.4. Test Procedure

The power cord of the EUT is connected to the output of the test system. Turn on the power of the EUT and use the test system to test the harmonic current level.

7.5. Test Results

The product's power provide by DC, no requirement for this item.

SHENZHEN YARUI TESTING CO., LTD.

Address: No.1107-1109, Weidonglong Technology Building, Meilong Avenue, Qinghu Longhua District ,
Shenzhen 518109, Guangdong, China

Tel.: +86-755-27912080 Fax.: +86-755-27916936 Website: www.yarui-lab.com

8. ELECTROSTATIC DISCHARGE IMMUNITY TEST

8.1. Block Diagram of Test Setup



8.2. Test Standard

EN 61547:2009, EN 61000-4-2:2009

Severity Level: 3 / Air Discharge: $\pm 8\text{KV}$

Level: 2 / Contact Discharge: $\pm 4\text{KV}$

8.3. Severity Levels and Performance Criterion

7.3.1 Severity level

Level	Test Voltage Contact Discharge (KV)	Test Voltage Air Discharge (KV)
1.	± 2	± 2
2.	± 4	± 4
3.	± 6	± 8
4.	± 8	± 15
X	Special	Special

SHENZHEN YARUI TESTING CO., LTD.

Address: No.1107-1109, Weidonglong Technology Building, Meilong Avenue, Qinghu Longhua District ,
Shenzhen 518109, Guangdong, China

Tel.: +86-755-27912080 Fax.: +86-755-27916936 Website: www.yarui-lab.com

7.3.2 Performance criterion : B

A. The equipment shall continue to operate as intended without operator intervention. No degradation of performance or loss of function is allowed below a performance level specified by the manufacturer when the equipment is used as intended. The performance level may be replaced by a permissible loss of performance. If the minimum performance level or the permissible performance loss is not specified by the manufacturer, then either of these may be derived from the product description and documentation, and by what the user may reasonably expect from the equipment if used as intended.

B. After the test, the equipment shall continue to operate as intended without operator intervention. No degradation of performance or loss of function is allowed, after the application of the phenomena below a performance level specified by the manufacturer, when the equipment is used as intended. The performance level may be replaced by a permissible loss of performance.

During the test, degradation of performance is allowed. However, no change of operating state or stored data is allowed to persist after the test.

If the minimum performance level (or the permissible performance loss) is not specified by the manufacturer, then either of these may be derived from the product description and documentation, and by what the user may reasonably expect from the equipment if used as intended.

C. Loss of function is allowed, provided the function is self-recoverable, or can be restored by the operation of the controls by the user in accordance with the manufacturer's instructions. Functions, and/or information stored in non-volatile memory, or protected by a battery backup, shall not be lost.

8.4.EUT Configuration

The following equipments are installed on Electrostatic Discharge Immunity test to meet EN 61547:2009, EN 61000-4-2:2009, requirement and operating in a manner which tends to maximize its emission characteristics in a normal application. The configuration of EUT is the same as used in conducted emission test.

Please refer to Section 2.4.

SHENZHEN YARUI TESTING CO., LTD.

Address: No.1107-1109, Weidonglong Technology Building, Meilong Avenue, Qinghu Longhua District ,

Shenzhen 518109, Guangdong, China

Tel.: +86-755-27912080 Fax.: +86-755-27916936 Website: www.yarui-lab.com

8.5. Operating Condition of EUT

Same as conducted emission measurement, which is listed in Section 3.5 except the test setup replaced by Section 7.1.2.

8.6. Test Procedure

7.6.1 Air Discharge:

This test is done on a non-conductive surface. The round discharge tip of the discharge electrode shall be approached as fast as possible to touch the EUT. After each discharge, the discharge electrode shall be removed from the EUT. The generator is then re-triggered for a new single discharge and repeated 10 times for each pre-selected test point. This procedure shall be repeated until all the air discharge completed.

7.6.2 Contact Discharge:

All the procedure shall be same as Section 7.6.1. Except that the tip of the discharge electrode shall touch the EUT before the discharge switch is operated.

7.6.3 Indirect discharge for horizontal coupling plane

At least 10 single discharges (in the most sensitive polarity) shall be applied at the front edge of each HCP opposite the center point of each unit (if applicable) of the EUT and 0.1m from the front of the EUT. The long axis of the discharge electrode shall be in the plane of the HCP and perpendicular to its front edge during the discharge.

7.6.4 Indirect discharge for vertical coupling plane

At least 10 single discharges (in the most sensitive polarity) shall be applied to the center of one vertical edge of the coupling plane. The coupling plane, of dimensions 0.5m X 0.5m, is placed parallel to, and positioned at a distance of 0.1m from the EUT. Discharges shall be applied to the coupling plane, with this plane in sufficient different positions that the four faces of the EUT are complete illuminated.

8.7. Test Results

PASS

Please refer to the following page.

SHENZHEN YARUI TESTING CO., LTD.

ESD Test Data				
Temperature:	24.5°C	Humidity:	53%	
Power Supply :	DC 3.6V	Test Mode:	On	
Air Discharge: ± 8KV				
Contact Discharge: ± 4KV				
Test Points	Air Discharge	Contact Discharge	Performance Criterion	Result
Enclosure	±2,4,8KV	N/A	B	PASS
Slit	±2,4,8KV	N/A	B	PASS
Metal Part	N/A	±2,4 KV	B	PASS
VCP	N/A	±2,4 KV	B	PASS
HCP	N/A	±2,4 KV	B	PASS
Note: N/A				

SHENZHEN YARUI TESTING CO., LTD.

Address: No.1107-1109, Weidonglong Technology Building, Meilong Avenue, Qinghu Longhua District ,
 Shenzhen 518109, Guangdong, China
 Tel.: +86-755-27912080 Fax.: +86-755-27916936 Website: www.yarui-lab.com

9. RF FIELD STRENGTH SUSCEPTIBILITY TEST

9.1. Block Diagram of Test Setup

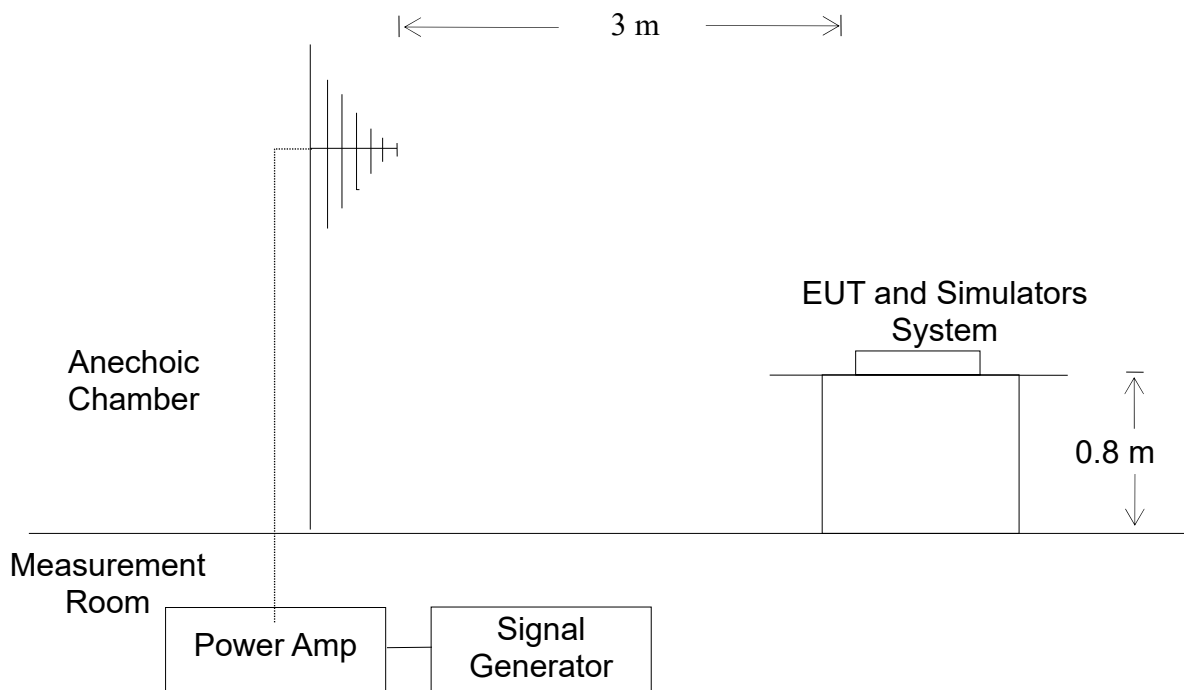

9.2. Test Standard

EN 61547:2009, EN 61000-4-3: 2006+A1:2008+A2:2010
Severity Level 2, 3V / m

9.3. Severity Levels and Performance Criterion

8.3.1. Severity level

Level	Field Strength V/m
1.	1
2.	3
3.	10
X.	Special

SHENZHEN YARUI TESTING CO., LTD.

Address: No.1107-1109, Weidonglong Technology Building, Meilong Avenue, Qinghu Longhua District ,
Shenzhen 518109, Guangdong, China
Tel.: +86-755-27912080 Fax.: +86-755-27916936 Website: www.yarui-lab.com

8.3.2. Performance criterion: A

- A、 The equipment shall continue to operate as intended without operator intervention. No degradation of performance or loss of function is allowed below a performance level specified by the manufacturer when the equipment is used as intended. The performance level may be replaced by a permissible loss of performance. If the minimum performance level or the permissible performance loss is not specified by the manufacturer, then either of these may be derived from the product description and documentation, and by what the user may reasonably expect from the equipment if used as intended.
- B、 After the test, the equipment shall continue to operate as intended without operator intervention. No degradation of performance or loss of function is allowed, after the application of the phenomena below a performance level specified by the manufacturer, when the equipment is used as intended. The performance level may be replaced by a permissible loss of performance.

During the test, degradation of performance is allowed. However, no change of operating state or stored data is allowed to persist after the test.

If the minimum performance level (or the permissible performance loss) is not specified by the manufacturer, then either of these may be derived from the product description and documentation, and by what the user may reasonably expect from the equipment if used as intended.

- C、 Loss of function is allowed, provided the function is self-recoverable, or can be restored by the operation of the controls by the user in accordance with the manufacturer's instructions. Functions, and/or information stored in non-volatile memory, or protected by a battery backup, shall not be lost.

9.4. EUT Configuration on Test

The following equipments are installed on Electrical Fast Transient/Burst Immunity test to meet EN 61547:2009, EN 61000-4-4:2012, requirement and operating in a manner which tends to maximize its emission characteristics in a normal application. The configuration of EUT is the same as used in conducted emission test.

Please refer to Section 3.4.

9.5. Operating Condition of EUT

Same as conducted emission measurement, which is listed in Section 2.5 except the test setup replaced by Section 8.1.

SHENZHEN YARUI TESTING CO., LTD.

Address: No.1107-1109, Weidonglong Technology Building, Meilong Avenue, Qinghu Longhua District ,

Shenzhen 518109, Guangdong, China

Tel.: +86-755-27912080 Fax.: +86-755-27916936 Website: www.yarui-lab.com

9.6. Test Procedure

The EUT and its simulators are placed on a turn table which is 0.8 meter above ground. EUT is set 3 meter away from the transmitting antenna which is mounted on an antenna tower. Both horizontal and vertical polarization of the antenna are set on test. Each of the four sides of EUT must be faced this transmitting antenna and measured individually.

All the scanning conditions are as follows :

Condition of Test	Remarks
1. Fielded Strength	3 V/m (Severity Level 2)
2. Radiated Signal	Modulated
3. Scanning Frequency	80 – 1000 MHz
4. Dwell time of radiated	0.0015 decade/s
5. Waiting Time	1 Sec.

9.7. Test Results

PASS

Please refer to the following page.

R/S Test Data			
Temperature : 25°C		Humidity : 53%	
Field Strength: 3 V/m		Criterion: A	
Power Supply: DC 3.6V		Frequency Range: 80 MHz to 1000 MHz	
Modulation: <input checked="" type="checkbox"/> AM <input type="checkbox"/> Pulse <input type="checkbox"/> none 1 KHz 80%			
Test Mode : On			
Frequency Range : 80-1000MHz			
Steps	1 %		
	Horizontal	Vertical	Result
Front	A	A	Pass
Right	A	A	Pass
Rear	A	A	Pass
Left	A	A	Pass
Note: N/A			

SHENZHEN YARUI TESTING CO., LTD.

10. ELECTRICAL FAST TRANSIENT/BURST IMMUNITY TEST

10.1. Block Diagram of EUT Test Setup

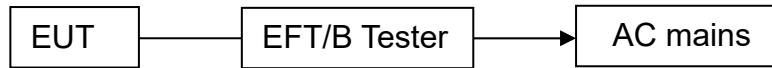

10.2. Test Standard

EN 61547:2009, EN 61000-4-4:2012

10.3. Severity Levels and Performance Criterion

Severity Level 2 at 1KV, Pulse Rise time & Duration: 5 nS / 50 nS

Severity Level:

Open Circuit Output Test Voltage $\pm 10\%$		
Level	On power ports	On I/O(Input/Output) Signal data and control ports
1.	0.5KV	0.25KV
2.	1KV	0.5KV
3.	2KV	1KV
4.	4KV	2KV
X.	Special	Special

Performance criterion: B

- A. The equipment shall continue to operate as intended without operator intervention. No degradation of performance or loss of function is allowed below a performance level specified by the manufacturer when the equipment is used as intended. The performance level may be replaced by a permissible loss of performance. If the minimum performance level or the permissible performance loss is not specified by the manufacturer, then either of these may be derived from the product description and documentation, and by what the user may reasonably expect from the equipment if used as intended.
- B. After the test, the equipment shall continue to operate as intended without operator intervention. No degradation of performance or loss of function is allowed, after the application of the phenomena below a performance level specified by the manufacturer, when the equipment is used as intended. The performance level may be replaced by a permissible loss of performance.

During the test, degradation of performance is allowed. However, no change of operating state or stored data is allowed to persist after the test.

SHENZHEN YARUI TESTING CO., LTD.

Address: No.1107-1109, Weidonglong Technology Building, Meilong Avenue, Qinghu Longhua District ,

Shenzhen 518109, Guangdong, China

Tel.: +86-755-27912080 Fax.: +86-755-27916936 Website: www.yarui-lab.com

If the minimum performance level (or the permissible performance loss) is not specified by the manufacturer, then either of these may be derived from the product description and documentation, and by what the user may reasonably expect from the equipment if used as intended.

- C. Loss of function is allowed, provided the function is self-recoverable, or can be restored by the operation of the controls by the user in accordance with the manufacturer's instructions. Functions, and/or information stored in non-volatile memory, or protected by a battery backup, shall not be lost.

10.4. EUT Configuration on Test

The following equipments are installed on Electrical Fast Transient/Burst Immunity test to meet EN 61547:2009, EN 61000-4-4:2012, requirement and operating in a manner which tends to maximize its emission characteristics in a normal application. The configuration of EUT is the same as used in conducted emission test. Please refer to Section 3.4.

10.5. Operating Condition of EUT

Same as conducted emission measurement, which is listed in Section 2.6 except the test setup replaced by Section 9.1.

10.6. Test Procedure

EUT shall be placed 0.8m high above the ground reference plane which is a min. 1m*1m metallic sheet with 0.65mm minimum thickness. This reference ground plane shall project beyond the EUT by at least 0.1m on all sides and the minimum distance between EUT and all other conductive structure, except the ground plane beneath the EUT, shall be more than 0.5m

9.6.1. For input and output AC power ports:

The EUT is connected to the power mains by using a coupling device which couples the EFT interference signal to AC power lines. Both polarities of the test voltage should be applied during compliance test and the duration of the test is 2 minutes.

10.7. Test Results

The product's power provide by DC, no requirement for this item.

SHENZHEN YARUI TESTING CO., LTD.

11. SURGE TEST

11.1. Block Diagram of EUT Test Setup

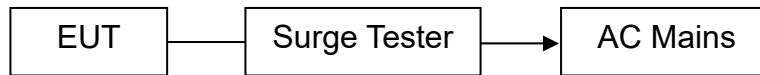

11.2. Test Standard

EN 61547:2009, EN 61000-4-5:2014+A1:2017

11.3. Severity Levels and Performance Criterion

Severity Level: Line to Line, Level 2 at 1KV;

Severity Level: Line to Earth, Level 3 at 2KV.

Severity Level	Open-Circuit Test Voltage (KV)
1.	0.5
2.	1.0
3.	2.0
4.	4.0
X.	Special

Performance criterion: B

- A. The equipment shall continue to operate as intended without operator intervention. No degradation of performance or loss of function is allowed below a performance level specified by the manufacturer when the equipment is used as intended. The performance level may be replaced by a permissible loss of performance. If the minimum performance level or the permissible performance loss is not specified by the manufacturer, then either of these may be derived from the product description and documentation, and by what the user may reasonably expect from the equipment if used as intended.
- B. After the test, the equipment shall continue to operate as intended without operator intervention. No degradation of performance or loss of function is allowed, after the application of the phenomena below a performance level specified by the manufacturer, when the equipment is used as intended. The performance level may be replaced by a permissible loss of performance.

During the test, degradation of performance is allowed. However, no change of operating state or stored data is allowed to persist after the test.

SHENZHEN YARUI TESTING CO., LTD.

Address: No.1107-1109, Weidonglong Technology Building, Meilong Avenue, Qinghu Longhua District ,

Shenzhen 518109, Guangdong, China

Tel.: +86-755-27912080 Fax.: +86-755-27916936 Website: www.yarui-lab.com

If the minimum performance level (or the permissible performance loss) is not specified by the manufacturer, then either of these may be derived from the product description and documentation, and by what the user may reasonably expect from the equipment if used as intended.

- C. Loss of function is allowed, provided the function is self-recoverable, or can be restored by the operation of the controls by the user in accordance with the manufacturer's instructions. Functions, and/or information stored in non-volatile memory, or protected by a battery backup, shall not be lost.

11.4. EUT Configuration on Test

The following equipments are installed on Electrical Fast Transient/Burst Immunity test to meet EN 61547:2009, EN 61000-4-5:2014+A1:2017, requirement and operating in a manner which tends to maximize its emission characteristics in a normal application

The configuration of EUT is the same as used in conducted emission test. Please refer to Section 3.4.

11.5. Operating Condition of EUT

Same as conducted emission measurement, which is listed in Section 2.7 except the test setup replaced by Section 10.1.

11.6. Test Procedure

- 1) Set up the EUT and test generator as shown on section 10.1
- 2) For line to line coupling mode, provide a 1KV 1.2/50us voltage surge (at open-circuit condition) and 8/20us current surge to EUT selected points.
- 3) At least 5 positive and 5 negative (polarity) tests with a maximum 1/min repetition rate are conducted during test.
- 4) Different phase angles are done individually.
- 5) Repeat procedure 2) to 4) except the open-circuit test voltage change from 1KV to 2KV for line to earth coupling mode test.
- 6) Record the EUT operating situation during compliance test and decide the EUT immunity criterion for above each test.

11.7. Test Result

The product's power provide by DC, no requirement for this item.

SHENZHEN YARUI TESTING CO., LTD.

12. INJECTED CURRENTS SUSCEPTIBILITY TEST

12.1. Block Diagram of EUT Test Setup

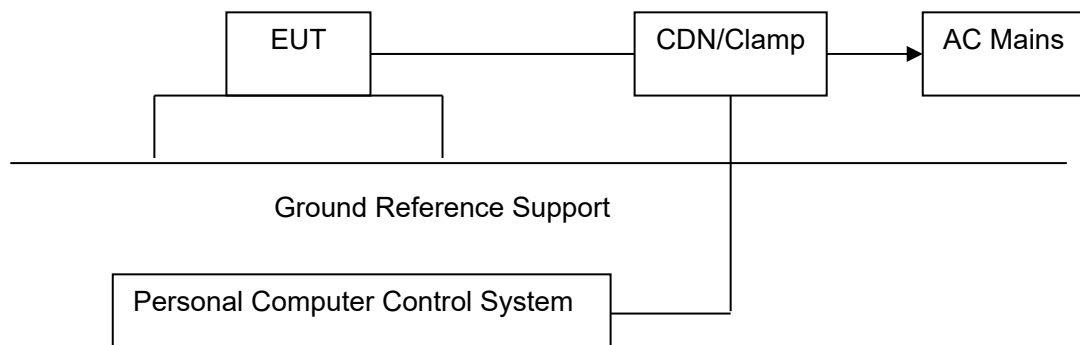

12.2. Test Standard

EN 61547:2009, EN61000-4-6:2014

12.3. Severity Levels and Performance Criterion

Severity Level 2: 3V(rms), 150KHz ~ 80MHz

Severity Level:

Level	Field Strength V
1.	1
2.	3
3.	10
X.	Special

Performance criterion: A

- A. The equipment shall continue to operate as intended without operator intervention. No degradation of performance or loss of function is allowed below a performance level specified by the manufacturer when the equipment is used as intended. The performance level may be replaced by a permissible loss of performance. If the minimum performance level or the permissible performance loss is not specified by the manufacturer, then either of these may be derived from the product description and documentation, and by what the user may reasonably expect from the equipment if used as intended.

SHENZHEN YARUI TESTING CO., LTD.

Address: No.1107-1109, Weidonglong Technology Building, Meilong Avenue, Qinghu Longhua District ,

Shenzhen 518109, Guangdong, China

Tel.: +86-755-27912080 Fax.: +86-755-27916936 Website: www.yarui-lab.com

- B. After the test, the equipment shall continue to operate as intended without operator intervention. No degradation of performance or loss of function is allowed, after the application of the phenomena below a performance level specified by the manufacturer, when the equipment is used as intended. The performance level may be replaced by a permissible loss of performance.

During the test, degradation of performance is allowed. However, no change of operating state or stored data is allowed to persist after the test.

If the minimum performance level (or the permissible performance loss) is not specified by the manufacturer, then either of these may be derived from the product description and documentation, and by what the user may reasonably expect from the equipment if used as intended.

- C. Loss of function is allowed, provided the function is self-recoverable, or can be restored by the operation of the controls by the user in accordance with the manufacturer's instructions. Functions, and/or information stored in non-volatile memory, or protected by a battery backup, shall not be lost.

12.4. EUT Configuration on Test

The configuration of EUT is the same as used in conducted emission test. Please refer to Section 2.8.

12.5. Operating Condition of EUT

Same as conducted emission test, which is listed in Section 2.8 except the test set up replaced as Section 11.1.

12.6. Test Procedure

- 1) Set up the EUT, CDN and test generator as shown on section 11.1
- 2) Let EUT work in test mode and measure.
- 3) The EUT and supporting equipments are placed on an insulating support 0.1m high above a ground reference plane. CDN (coupling and decoupling device) is placed on the ground plane at above 0.1-0.3m from EUT. Cables between CDN and EUT are as short as possible, and their height above the ground reference plane shall be between 30 and 50 mm (where possible).
- 4) The disturbance signal described below is injected to EUT through CDN.
- 5) The EUT operates within its operational mode(s) under intended climatic conditions after power on.
- 6) The frequency range is swept from 150KHz to 80MHz using 3V signal level, and with the disturbance signal 80% amplitude modulated with a 1KHz sine wave

SHENZHEN YARUI TESTING CO., LTD.

Address: No.1107-1109, Weidonglong Technology Building, Meilong Avenue, Qinghu Longhua District ,

Shenzhen 518109, Guangdong, China

Tel.: +86-755-27912080 Fax.: +86-755-27916936 Website: www.yarui-lab.com

- 7) The rate of sweep shall not exceed 1.5×10^{-3} decades/s. Where the frequency is swept incrementally, the step size shall not exceed 1% of the start and thereafter 1% of the preceding frequency value.
- 8) Recording the EUT operating situation during compliance test and decide the EUT immunity criterion for above each test.

12.7. Test Result

The product's power provide by DC, no requirement for this item.

SHENZHEN YARUI TESTING CO., LTD.

Address: No.1107-1109, Weidonglong Technology Building, Meilong Avenue, Qinghu Longhua District ,
Shenzhen 518109, Guangdong, China

Tel.: +86-755-27912080 Fax.: +86-755-27916936 Website: www.yarui-lab.com

13. MAGNETIC FIELD IMMUNITY TEST

13.1. Block Diagram of Test Setup

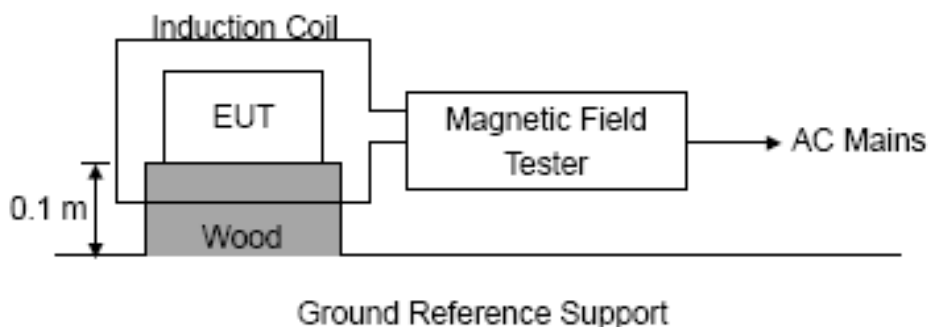

13.2. Test Standard

EN 61547:2009, EN61000-4-8:2010
Severity Level 1 at 1A/m

13.3. Severity Levels and Performance Criterion

12.3.1 Severity level

Level	Magnetic Field Strength A/m
1.	1
2.	3
3.	10
4.	30
5.	100
X.	Special

12.3.2 Performance criterion: B

A. The equipment shall continue to operate as intended without operator intervention. No degradation of performance or loss of function is allowed below a performance level specified by the manufacturer when the equipment is used as intended. The performance level may be replaced by a permissible loss of performance. If the minimum performance level or the permissible performance loss is not specified by the manufacturer, then either of these may be derived from the product description and documentation, and by what the user may reasonably expect from the equipment if used as intended.

B. After the test, the equipment shall continue to operate as intended

SHENZHEN YARUI TESTING CO., LTD.

Address: No.1107-1109, Weidonglong Technology Building, Meilong Avenue, Qinghu Longhua District ,
Shenzhen 518109, Guangdong, China
Tel.: +86-755-27912080 Fax.: +86-755-27916936 Website: www.yarui-lab.com

without operator intervention. No degradation of performance or loss of function is allowed, after the application of the phenomena below a performance level specified by the manufacturer, when the equipment is used as intended. The performance level may be replaced by a permissible loss of performance.

During the test, degradation of performance is allowed. However, no change of operating state or stored data is allowed to persist after the test.

If the minimum performance level (or the permissible performance loss) is not specified by the manufacturer, then either of these may be derived from the product description and documentation, and by what the user may reasonably expect from the equipment if used as intended.

- C. Loss of function is allowed, provided the function is self-recoverable, or can be restored by the operation of the controls by the user in accordance with the manufacturer's instructions. Functions, and/or information stored in non-volatile memory, or protected by a battery backup, shall not be lost.

13.4. EUT Configuration on Test

The configuration of EUT is listed in Section 2.9.

13.5. Operating Condition of EUT

Same as conducted emission test, which is listed in Section 2.9 except the test set up replaced as Section 12.1.

13.6. Test Procedure

The EUT shall be subjected to the test magnetic field by using the induction coil of standard dimensions (1m*1m) and shown in Section 10.1. The induction coil shall then be rotated by 90° in order to expose the EUT to the test field with different orientations.

13.7. Test Results

PASS

Please refer to the following page.

SHENZHEN YARUI TESTING CO., LTD.

Address: No.1107-1109, Weidonglong Technology Building, Meilong Avenue, Qinghu Longhua District ,

Shenzhen 518109, Guangdong, China

Tel.: +86-755-27912080 Fax.: +86-755-27916936 Website: www.yarui-lab.com

MS Test Data					
Temperature:	24.5°C		Humidity:	53%	
Power Supply :	DC 3.6V		Test Mode:	On	
Environmental Phenomena	Test specification	Units	Coil Orientation	Performance Criterion	Result
Magnetic Field	3	A/m	X	A	PASS
			Y	A	PASS
			Z	A	PASS
Note: N/A					

SHENZHEN YARUI TESTING CO., LTD.

Address: No.1107-1109, Weidonglong Technology Building, Meilong Avenue, Qinghu Longhua District ,
 Shenzhen 518109, Guangdong, China
 Tel.: +86-755-27912080 Fax.: +86-755-27916936 Website: www.yarui-lab.com

14. VOLTAGE DIPS AND INTERRUPTIONS TEST

14.1. Block Diagram of EUT Test Setup

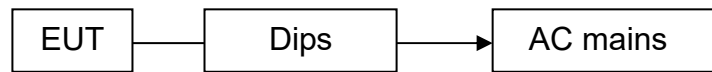

14.2. Test Standard

EN 61547:2009, EN61000-4-11:2004+A1:2017

14.3. Severity Levels and Performance Criterion

Severity Level:

Input and Output AC Power Ports.

Voltage Dips.

Voltage Interruptions.

Environmental Phenomena	Test Specification	Units	Performance Criterion
Voltage Dips	70 10	% Reduction period	C
	0 0.5	% Reduction period	B

Performance criterion: C, B

- A. The equipment shall continue to operate as intended without operator intervention. No degradation of performance or loss of function is allowed below a performance level specified by the manufacturer when the equipment is used as intended. The performance level may be replaced by a permissible loss of performance. If the minimum performance level or the permissible performance loss is not specified by the manufacturer, then either of these may be derived from the product description and documentation, and by what the user may reasonably expect from the equipment if used as intended.
- B. After the test, the equipment shall continue to operate as intended without operator intervention. No degradation of performance or loss of function is allowed, after the application of the phenomena below a performance level specified by the manufacturer, when the equipment is used as intended. The performance level may be replaced by a permissible loss of performance.

SHENZHEN YARUI TESTING CO., LTD.

Address: No.1107-1109, Weidonglong Technology Building, Meilong Avenue, Qinghu Longhua District ,

Shenzhen 518109, Guangdong, China

Tel.: +86-755-27912080 Fax.: +86-755-27916936 Website: www.yarui-lab.com

During the test, degradation of performance is allowed. However, no change of operating state or stored data is allowed to persist after the test.

If the minimum performance level (or the permissible performance loss) is not specified by the manufacturer, then either of these may be derived from the product description and documentation, and by what the user may reasonably expect from the equipment if used as intended.

- C. Loss of function is allowed, provided the function is self-recoverable, or can be restored by the operation of the controls by the user in accordance with the manufacturer's instructions. Functions, and/or information stored in non-volatile memory, or protected by a battery backup, shall not be lost.

14.4. EUT Configuration on Test

The configuration of EUT is the same as used in conducted emission test. Please refer to Section 2.10.

14.5. Operating Condition of EUT

Same as conducted emission test, which is listed in Section 2.10 except the test set up replaced as Section 13.1.

14.6. Test Procedure

- 1) Set up the EUT and test generator as shown on section 13.1
- 2) The interruption is introduced at selected phase angles with specified duration. There is a 3mins minimum interval between each test event.
- 3) After each test a full functional check is performed before the next test.
- 4) Repeat procedures 2 & 3 for voltage dips, only the level and duration is changed.
- 5) Record any degradation of performance.

14.7. Test Result

The product's power provide by DC, no requirement for this item.

SHENZHEN YARUI TESTING CO., LTD.

15. EUT TEST PHOTOGRAPHS

RE Test Photo



SHENZHEN YARUI TESTING CO., LTD.

Address: No.1107-1109, Weidonglong Technology Building, Meilong Avenue, Qinghu Longhua District ,
Shenzhen 518109, Guangdong, China

Tel.: +86-755-27912080 Fax.: +86-755-27916936 Website: www.yarui-lab.com

16. EUT PHOTOGRAPHS

EUT Photo 1



EUT Photo 2



SHENZHEN YARUI TESTING CO., LTD.

Address: No.1107-1109, Weidonglong Technology Building, Meilong Avenue, Qinghu Longhua District ,
Shenzhen 518109, Guangdong, China

Tel.: +86-755-27912080 Fax.: +86-755-27916936 Website: www.yarui-lab.com

EUT Photo 3



EUT Photo 4



SHENZHEN YARUI TESTING CO., LTD.

Address: No.1107-1109, Weidonglong Technology Building, Meilong Avenue, Qinghu Longhua District ,
Shenzhen 518109, Guangdong, China
Tel.: +86-755-27912080 Fax.: +86-755-27916936 Website: www.yarui-lab.com

EUT Photo 5



***** END OF REPORT *****

SHENZHEN YARUI TESTING CO., LTD.

Address: No.1107-1109, Weidonglong Technology Building, Meilong Avenue, Qinghu Longhua District ,
Shenzhen 518109, Guangdong, China
Tel.: +86-755-27912080 Fax.: +86-755-27916936 Website: www.yarui-lab.com