

PRODUCT INSTALLATION GUIDE

X1



SIZE: 60*68*116.5(126.5)CM

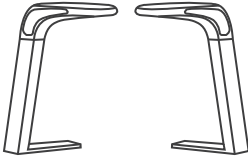
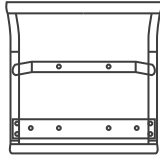
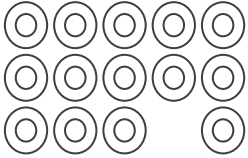
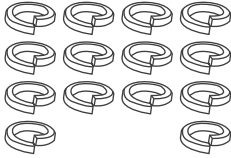
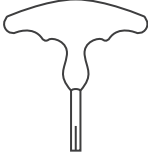
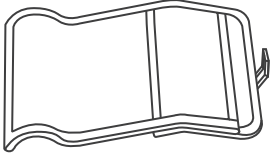
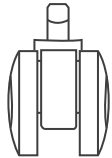
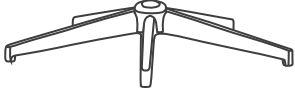
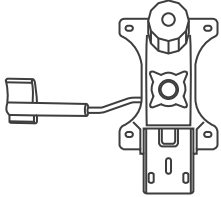
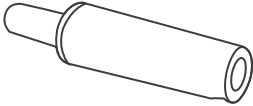
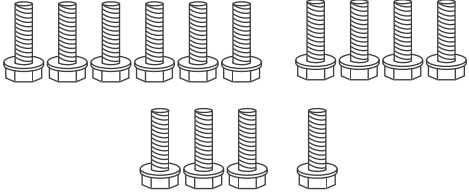

Parts list (According to the actual size; each type of screw and gasket have a spare.)

		
Armrest*1 pair	Seat cushion*1 pc	Shim 13+1 pcs
		
Spring leaf 13+1pcs	Hex wrench*1 pc	Backrest*1 pc
		
Castores*5 pcs	Base *1 pc	Mechanism *1 pc
		
Gaslift*1 pcs	Armrest screw / mechanism screw / back screw (M8 * 20) 13 + 1	

Note: before installing the chair, please sort the screws and measure the screw length for installation.

Installation diagram (Subject to actual size.)

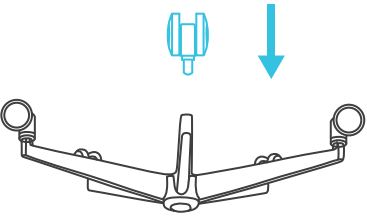
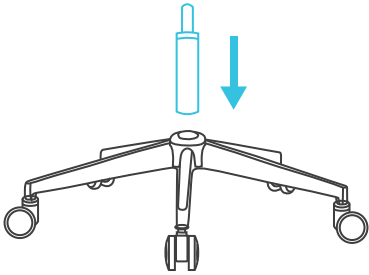
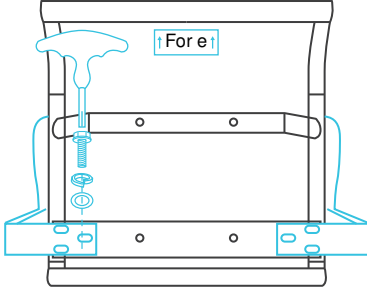
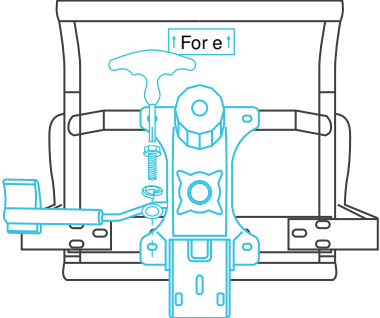
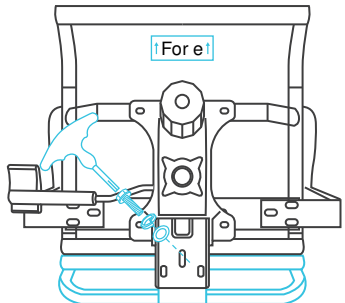
Installation steps of swivel chair

	
1 Put the castor into the base by pressing.	2 Insert the gaslift to the base.
	
3 Six screws (M8 * 20) with spring and Shim are used to install the armrest on the seat cushion.	4 Four screws (M8 * 20) with spring and shim are used to install the mechanism on the seat cushion.
	
5 Align the backrest to the tail plate of the mechanism, fix the backrest on the mechanism with 3 screws (M8 * 20)+spring leaf and shim, Fix the position before tightening the screw.	6 Install the upper part of chair to the gas lift.

Function diagram (Subject to actual size)

