

Fig 9

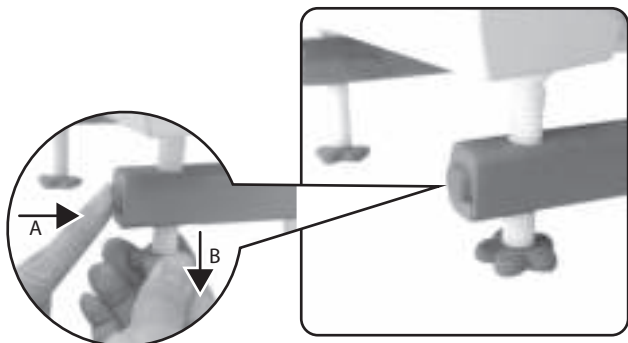

Fig 10



BA_703168_0220



DE, AT, BE, CH, NL, LU: Zapf Creation AG, Mönchrödener Str. 13, D-96472 Rödentel, Germany.
 GB, IE: Zapf Creation (UK) Ltd., 50 Presley Way, Crownhill, Milton Keynes, MK8 0ES, Bucks, UK.
 CZ: Zapf Creation AG, Štětškova 5, 140 00 Praha 4 - Nusle, Czech Republic.
 HK: Zapf Creation (H.K.) Ltd., Suite 301, 3/F., Chinachem Golden Plaza, No. 77 Mody Road, Tsimshatsui East, Kowloon, Hong Kong, S.A.R. China.
 US, CA: MGA Entertainment Inc., 9220 Winnetka Ave, Chatsworth, CA 91311, U.S.A. (800) 222-4685
 AU: Imported by MGA Entertainment Australia Pty Ltd, Suite 2.02, 32 Delhi Road, Macquarie Park NSW 2113. Customer Service: +61 1 300 059 676
 ES: Distribuido por: Bandai España S.A., Avda. del Partenón nº 10, Planta 1 28042 Madrid. España, C.I.F.: A-19159573.
 FR: Distribué par: GP TOYS France, 93, rue de la Villette, 69003 Lyon, France, Service Consommateur: contact@gptoysfrance.fr
 IT: Distribuito da: Giocheria S.p.A./Giochi Preziosi Italia Srl, Via delle Primule 5, 20815 Cogliate (MB), Italia, Servizio Consumatori : +39/02/96.46.11.70
 PL: Imported by MGA Entertainment Poland Sp. z o.o. Ul. Grottgera 15a 76-200 Slupsk, Polska

Baby Annabell® and  are internationally registered trademarks of Zapf Creation AG.
 © Copyright 2020 Zapf Creation AG

Zapf Creation AG
 Mönchrödener Straße 13
 D-96472 Rödentel, Germany
 www.zapf-creation.com
Made in China
Fabriqué en Chine



www.baby-annabell.com/703168

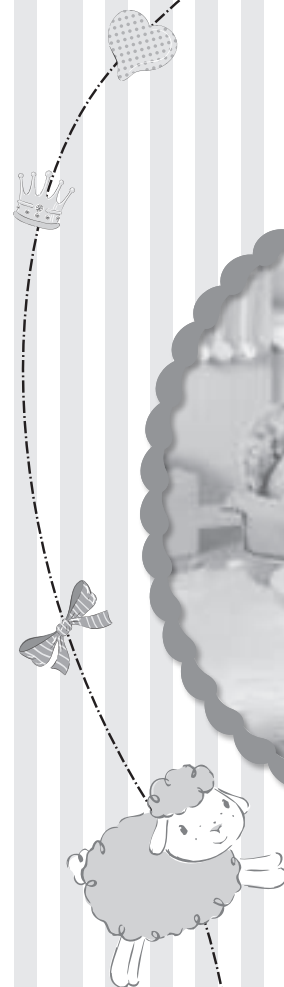

703168



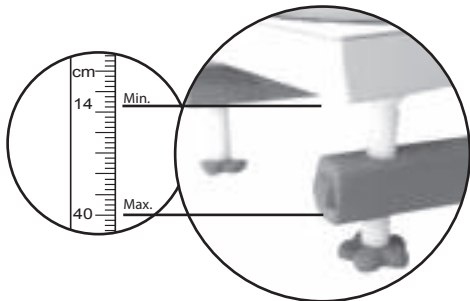

DE Seien Sie sich stets der Aufsichtspflicht gegenüber Ihrem Kind bewusst. Der Aufbau ist von Erwachsenen durchzuführen.
GB Be aware of supervising your child. To be assembled by adults.
FR Votre enfant doit rester sous votre surveillance. Le montage doit être effectué par des adultes.
NL Houd altijd toezicht op uw kind. De opbouw moet door volwassenen uitgevoerd worden.
IT Non perdetevi mai di vista il vostro bambino durante il gioco. Assemblabili dagli adulti.
ES Por favor, supervise a su hijo/a en todo momento. El montaje debe ser realizado por adultos.
PT A criança deve brincar sob a supervisão de um adulto. A montagem deverá ser executada por des adultos.
NO Ha tilsyn med barnet. Monteringen skal utføres av voksne.
SE Håll barn under uppsyn. Monteringen ska genomföras av vuxna.
FI Suosittelemme aikuisen valvontaa. Aikuisen tulee asentaa osat paikalleen.
DK Hold opsyn med barnet. Opstillingen skal foretages af voksne personer.
HU Tudatosan felügyelje gyermekét. Összeszerelését felnőtt végezheti.
CZ Používejte pouze pod dohledem dospělé osoby. Sestavu mohou provádět dospělí osoby.
PL Sprawó nadzór nad dzieckiem w czasie zabawy. Do montażu przez osoby dorosłe.
SK Používajte iba pod dohľadom dospeljej osoby. Môžu skladať len dospelé osoby.
SI Nadzorujte svojega otroka. Postavitev naj opravijo odrasle osebe.
TR Daima çocuğunuzla karşı sahip olduğunuz gözcülük görevinin bilincinde olunuz. Kurm a işlemi yetişkin kişiler tarafından yapılmalıdır.
RU Не забывайте наблюдать за Вашим ребенком. Сборка должна осуществляться взрослыми.
LV Pieskatiet bērnu. Salikt pieaugušajiem.
LT Visada prižiūrėkite žaidžiantį vaiką. Surinkti turi suaugusieji.
EE Palun jälgige oma last mängu ajal. Kokkupanekut teostab täiskasvanu.
IS Verið meðvítuð um að leiðbeina barni ykkar. Fullorðnir sjái um samsetningu.
GR Μη ξεχνάτε ποτέ το καθήκον επίβλεψης που έχετε έναντι του παιδιού σας. Η συναρμολόγηση να γίνεται από ενήλικα πρόσωπα.
RO Supravegheați-vă cu atenție copilul. A se asambla de către adulți.
HR/BA Uпотреba uz nadzor odraslih osoba. Sastavljati smiju odrasli.
BG Моля, наблюдавайте детето си при игра. Да се сглобява от възрастни лица.
UA Не забувайте стежити за Вашою дитиною. Призначено для складання дорослими.
AE يتم تجميعه بواسطة البالغين. تأكد من ملاحظة طفلك.

Fig 1



Fig 2

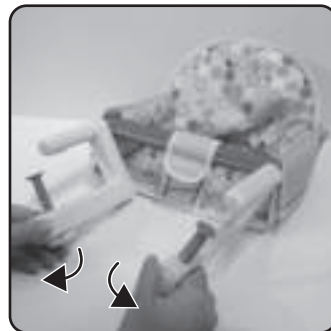

Fig 3



Fig 4

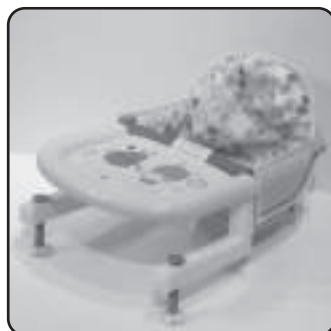

Fig 5

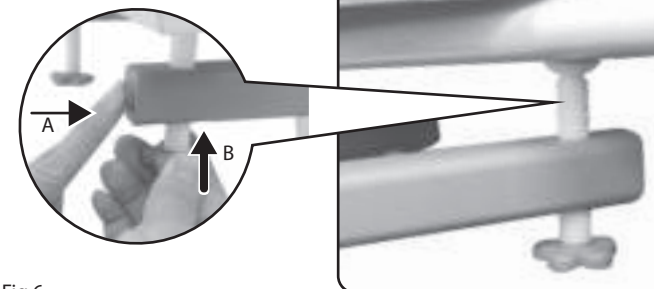

Fig 6

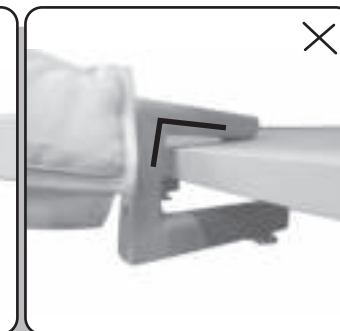
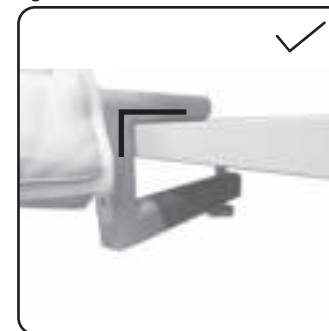

Fig 7



Fig 8

