

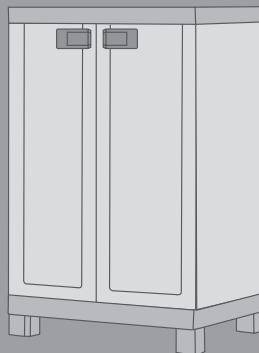

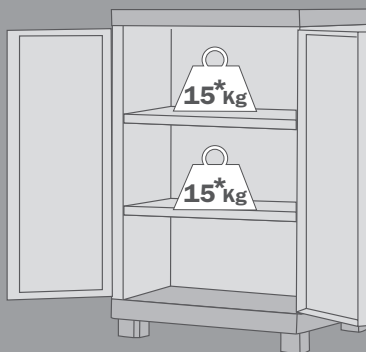









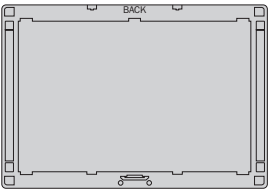





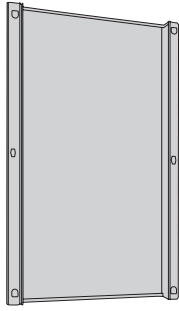

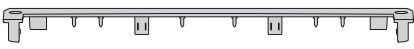

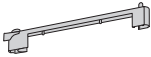
LOGICO

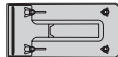
9635000
cm 65x45x97 h

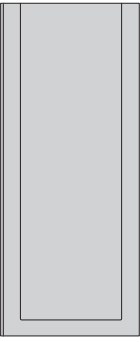

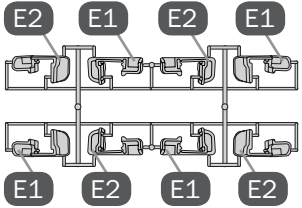

- I Istruzioni per il montaggio
- GB Assembly instruction
- D Montageanleitungen
- F Instructions pour le montage
- E Instrucción para el montaje
- NL Instructies voor de montage
- TR Montaj talimatları
- GR Οδηγίες συναρμολόγησης
- RUS Инструкции за монтаж
- RO Instrucțiuni de montaj
- CZ Návod na montáž
- PL Instrukcja montażu

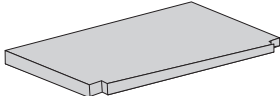

* Distribuiti uniformemente - Equally distributed - Gleichmäßig verteilt - Distribué uniformement - Uniformemente distribuido - Op gelijkmatige wijze verdeeld - Ağırlik eşit olarak dağıtılmaldır - Καταμετρημένο ομοιόμορφα - Равномерно распределеная - Distribuite in mod egal - Rovnoměrně rozložené - Jednolice rozložone obciążenie

<p>2xAC</p> 	<p>4xT</p> 	<p>2xA1</p> 	<p>2xA2</p> 
<p>2xA3</p> 		<p>2xA4</p> 	
<p>2xB1</p> 	<p>1x</p> 	<p>2xC2</p> 	
<p>1xCDS/CDSL</p> 		<p>1xCLD</p> 	<p>1xCLS</p> 
<p>1xCDD/CDDL</p> 		<p>2xB6</p> 	<p>2xD5</p> 
<p>2xDSU</p> 		<p>4x [4,2x22mm]</p> 	<p>4x [Ø5,3x10 mm]</p> 
<p>4x [3,9X16mm]</p> 		<p>1x</p> 	
<p>2xTT</p> 		<p>2xRA</p> 	

TRIBAC OPTION

<p>1x SX</p> 	<p>1x</p> 	<p>1x DX</p> 	<p>6x</p> 
--	--	---	---



- I** Conservare il manuale d'uso per referenze future in prossimità del prodotto. Prima di iniziare l'assemblaggio leggere attentamente le avvertenze.
- GB** Keep this instruction manual with the product for future reference. Read the instructions carefully before assembly. **D** Bewahren Sie das Benutzerhandbuch in der Nähe des Produkts auf, damit Sie später jederzeit nachschlagen können. Lesen Sie vor der Montage die Anweisungen aufmerksam durch. **F** Conserver le manuel d'utilisation à proximité du produit pour de futures références. Lire attentivement la notice avant de commencer l'assemblage. **E** Guarde el manual de uso para futuras consultas cerca del producto. Antes de empezar el montaje, lea detenidamente las advertencias. **NL** Bewaar de handleiding in nabijheid van het product voor toekomstige raadpleging. Lees deze voorschriften aandachtig alvorens met de montage te beginnen. **TR** Kılavuzu ileride başvurmak üzere ürüne yakın bir yerde saklayın. Montaja başlamadan önce etiketleri dikkatle okuyun. **GR** Φυλάξτε αυτό το εγχειρίδιο χρήσης κοντά στο προϊόν για μελλοντικές χρήσεις. Πριν ξεκινήσετε την συναρμολόγηση διαβάστε προσεχτικά τις προειδοποιήσεις ασφαλείας. **rus** Храните руководство пользователя поблизости от изделия для дальнейшего к нему обращения. Перед тем, как приступить к сборке, внимательно ознакомьтесь с предупреждениями.
- RO** Păstrați manualul de utilizare în apropierea produsului pentru consultări ulterioare. Înainte de a începe asamblarea citiți cu atenție avertismentele. **CZ** Uchovejte tento návod pro jeho případné další použití. Před montáží si pečlivě přečtěte instrukce. **PL** Przechowywać instrukcję obsługi w pobliżu produktu do przyszłych konsultacji. Przed rozpoczęciem montażu przeczytać uważnie pouczenia.

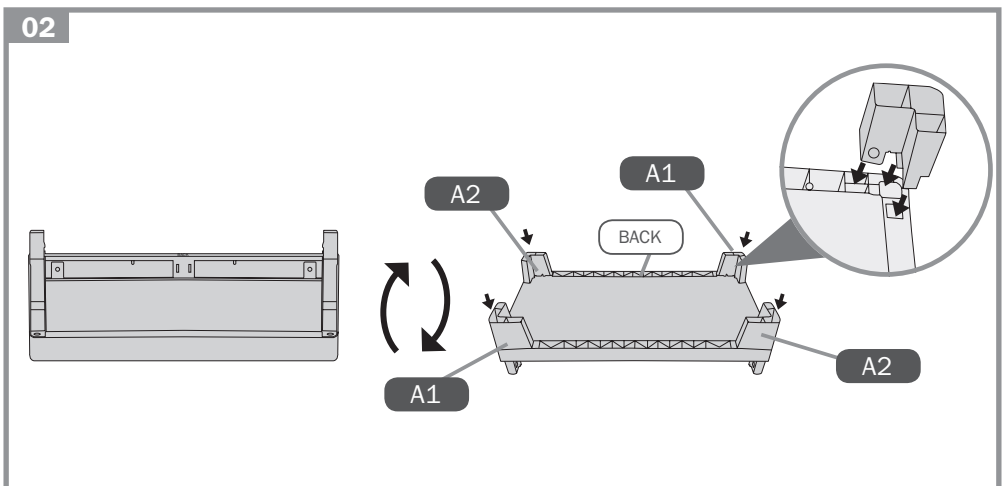
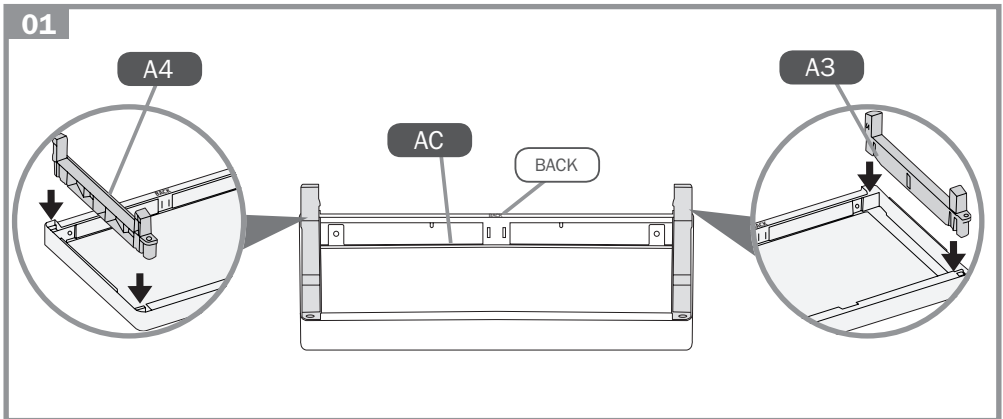

03

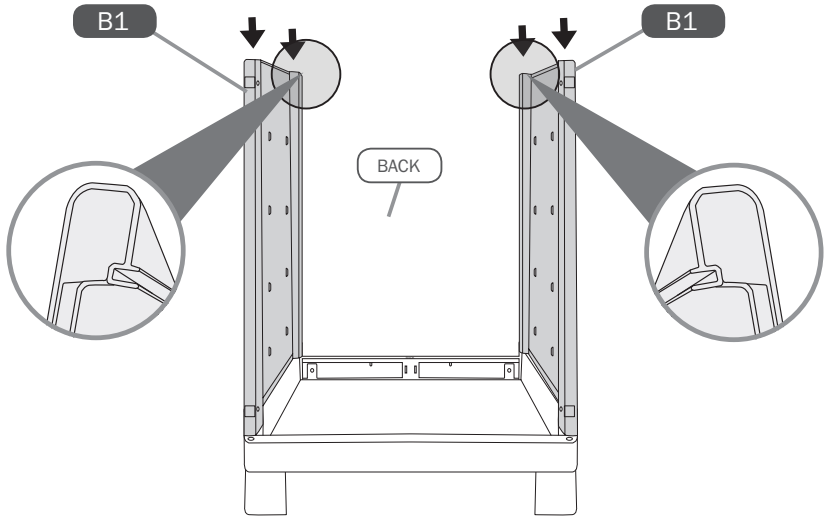

04

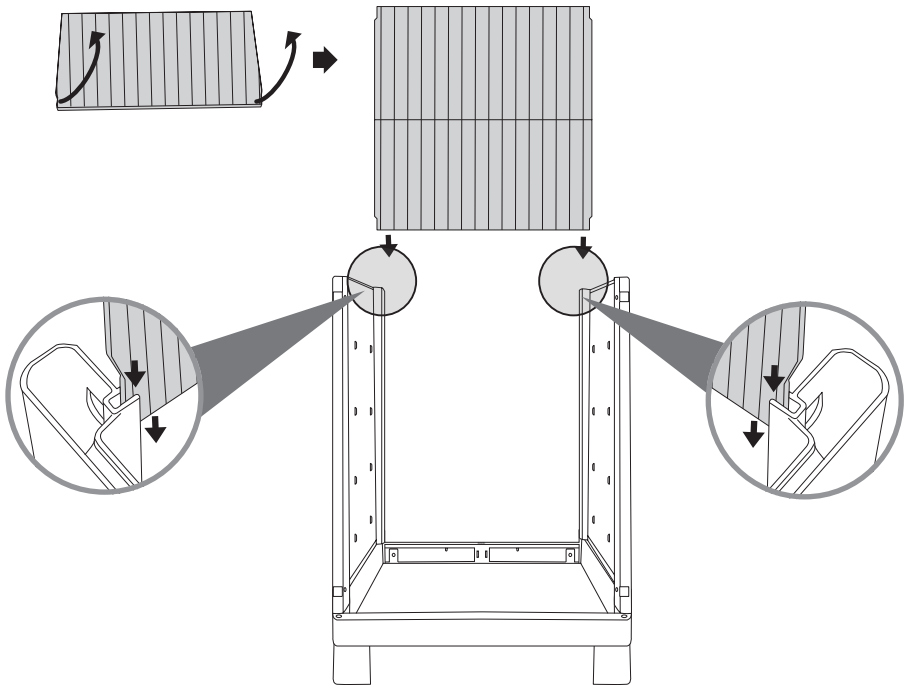

05

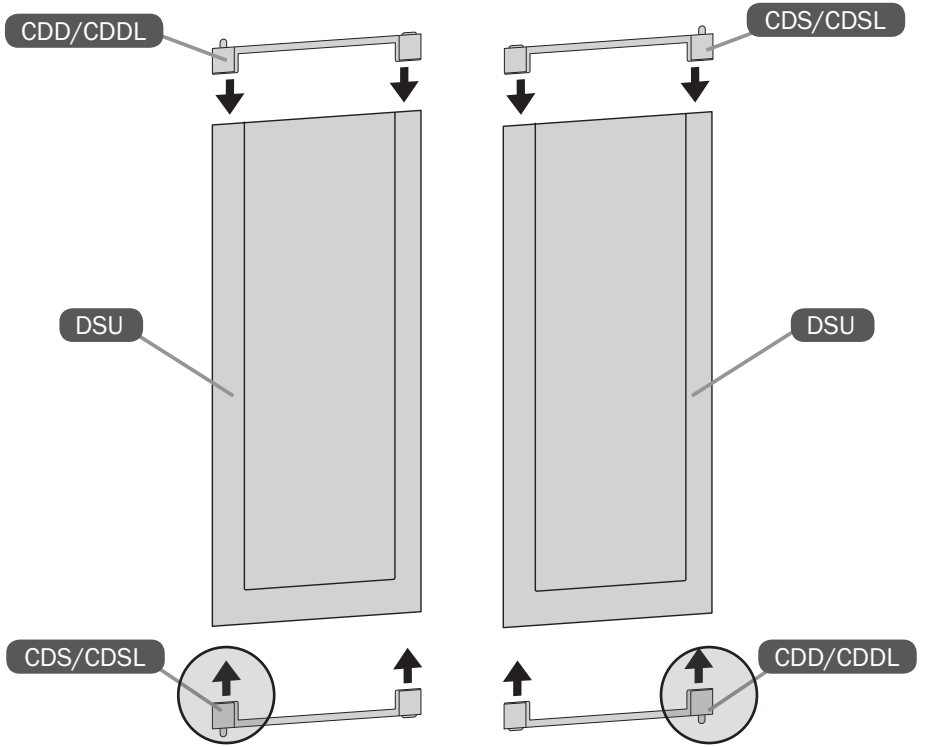

06

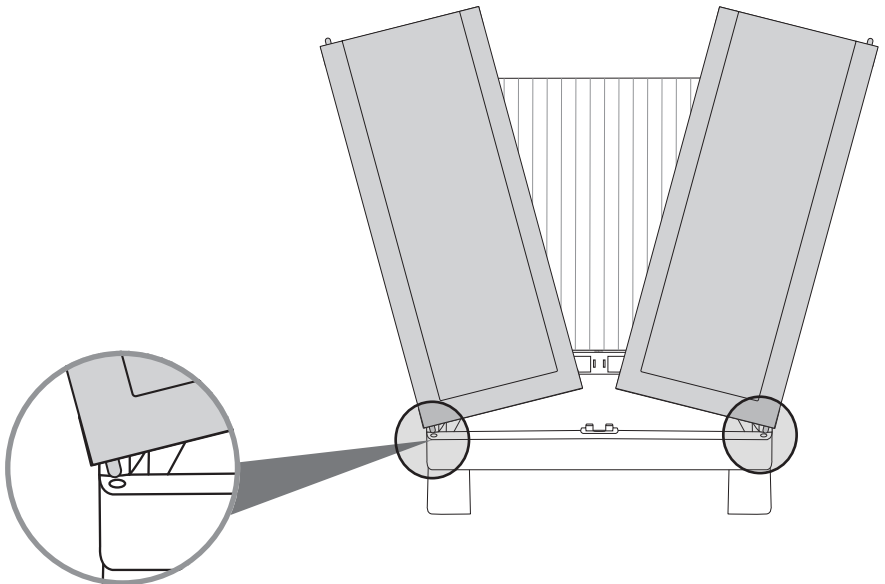

07

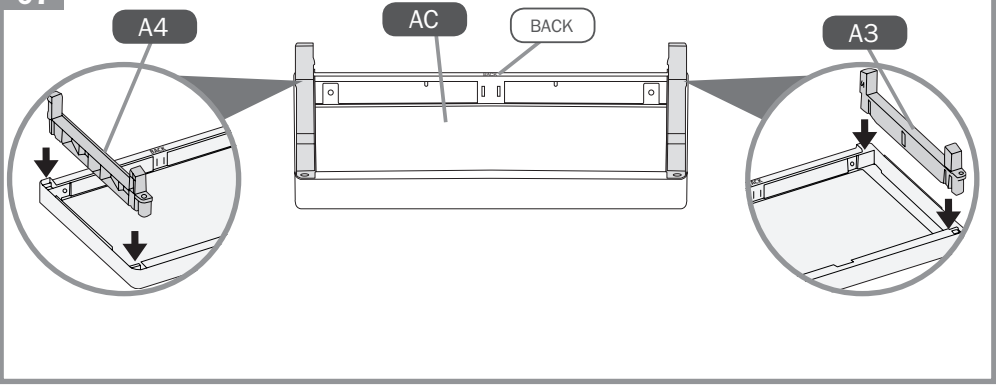

08

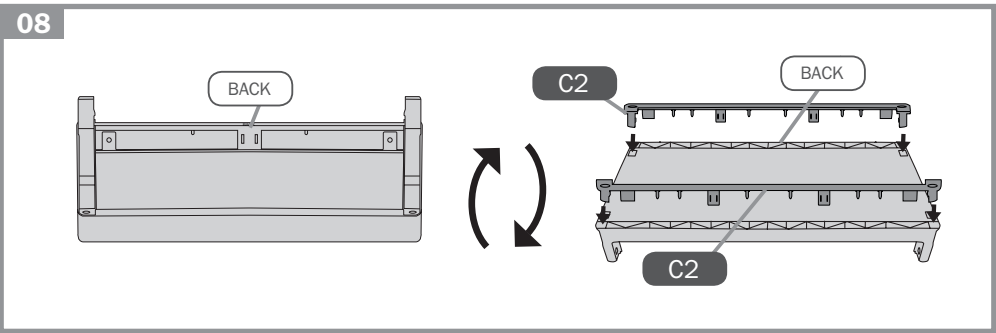

09

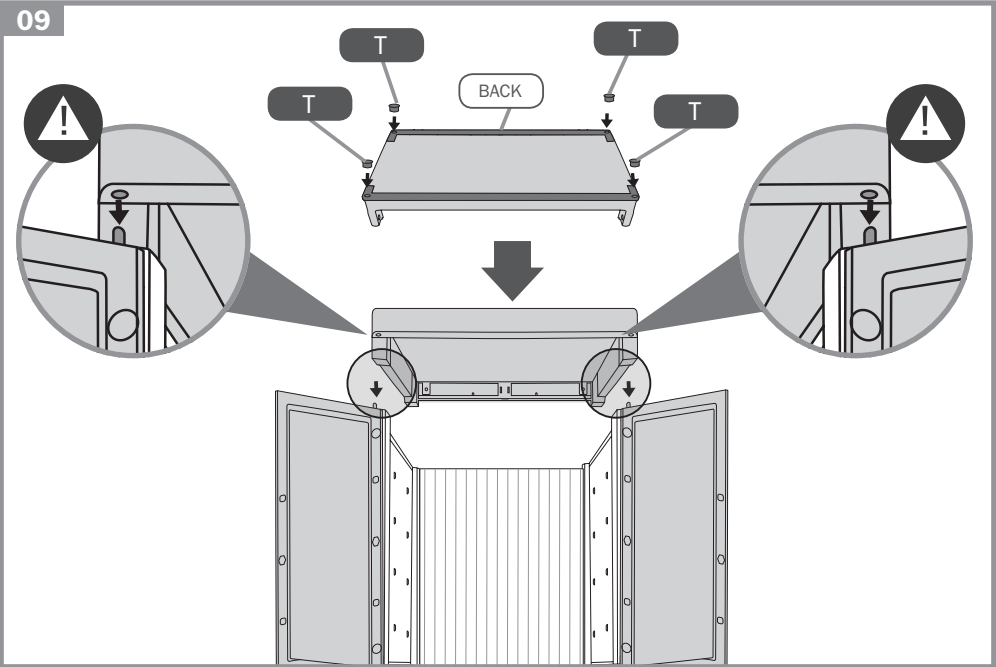

10

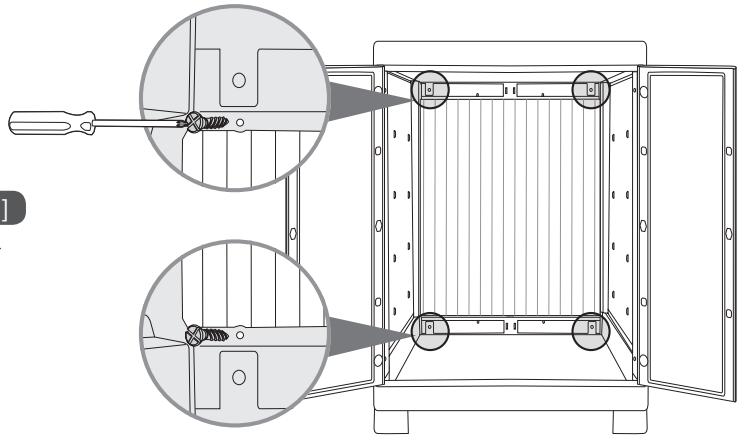

4x [3,9x16mm]



11

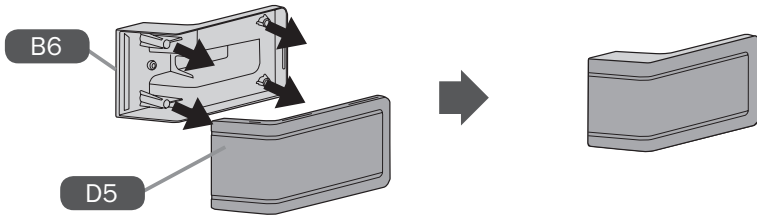

x2

12

4x [4,2x22mm]



4x [Ø5,3x10 mm]

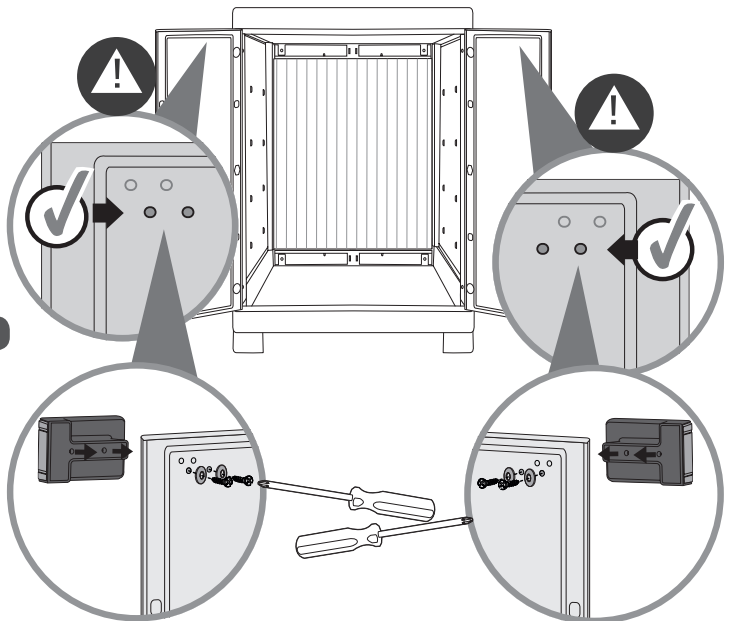

13

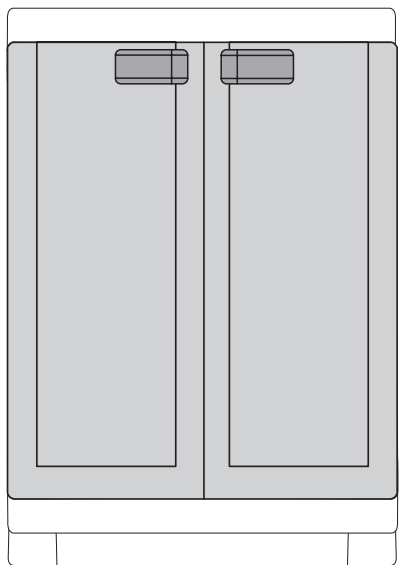

14

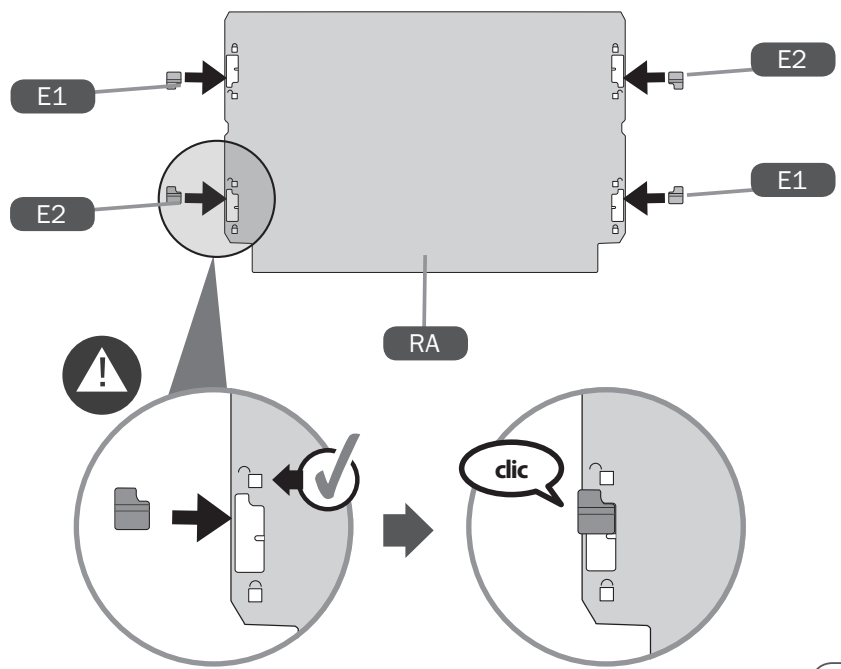

x2

15

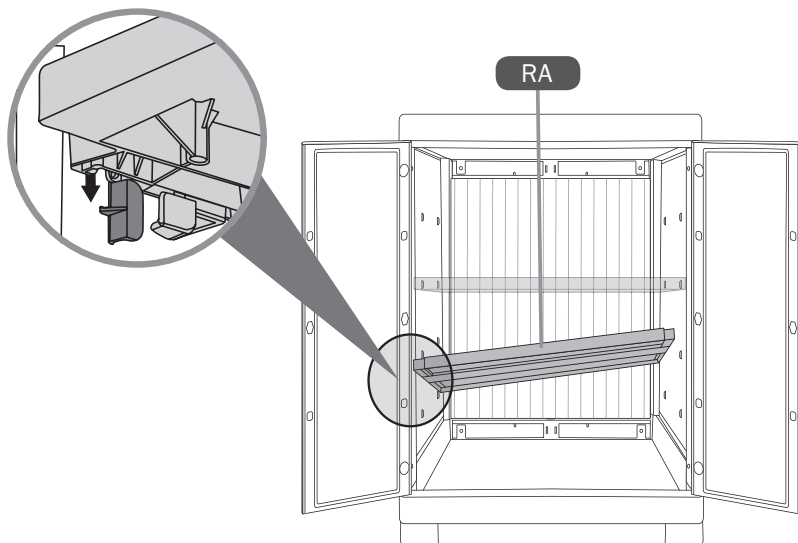

x2

16

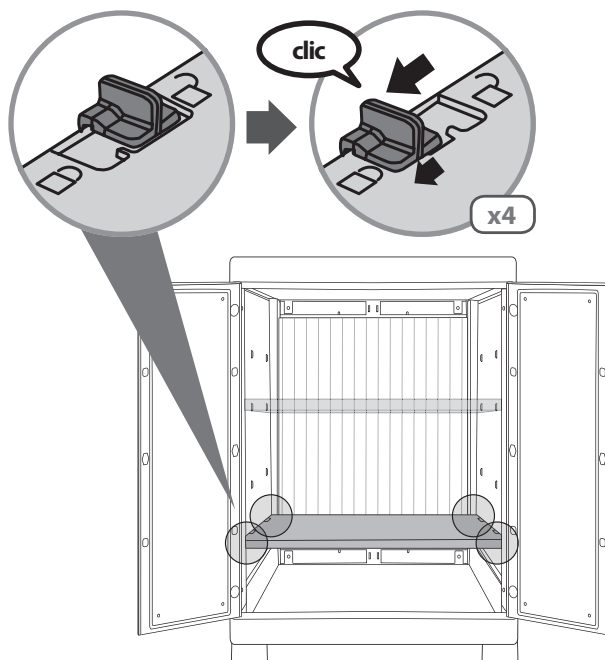

x2

I Fissare l'armadio a muro (viti e tasselli non inclusi). Scegliere il tassello in base alla superficie di appoggio. **GB** Fasten the cupboard to the wall (screws and anchors not included). Choose the anchor according to the surface. **D** Befestigen Sie den Schrank an der Wand (Schrauben und Dübel sind nicht im Lieferumfang enthalten). Den Dübel je nach Stellfläche wählen.

F Fixer l'armoire au mur (vis et chevilles non incluses). Choisir la cheville en fonction de la surface d'appui. **E** Fije el armario en la pared (la dotación no incluye tornillos y tacos). Elija el taco en función de la superficie de apoyo. **NL** Bevestig de kast aan de muur (schroeven en pluggen niet bijgeleverd). Kies de plug aan de hand van het steunoppervlak. **TR** Dolabı duvara sabitleyin (vidalar ve dübeller dahil değil). Destek yüzeyine göre dübel seçin. **GR** Στερεώστε την ντουλάπα στον τοίχο (βίδες και ούπα δεν περιλαμβάνονται). Επιλέξτε το ούπα ανάλογα με την επιφάνεια στήριξης. **RUS** Закрепите шкаф на стене (шурупы и дюбели не включены в поставку). Возьмите дюбель, пригодный для материала поверхности, у которой ставится шкаф.

RO Fixați dulapul la perete (șuruburi și dibluri neincluse în dotare). Alegeți diblul în funcție de suprafața pe care urmează să se fixeze. **CZ** Připevněte skříň ke zdi (šrouby a hmoždinky nejsou součástí dodávky). Zvolte hmoždinku podle povrchu podkladu.

PL Przymocować szafę do muru (śruby i kołki nie są zawarte w dostawie). Dobrać kołek w zależności od powierzchni oparcia.

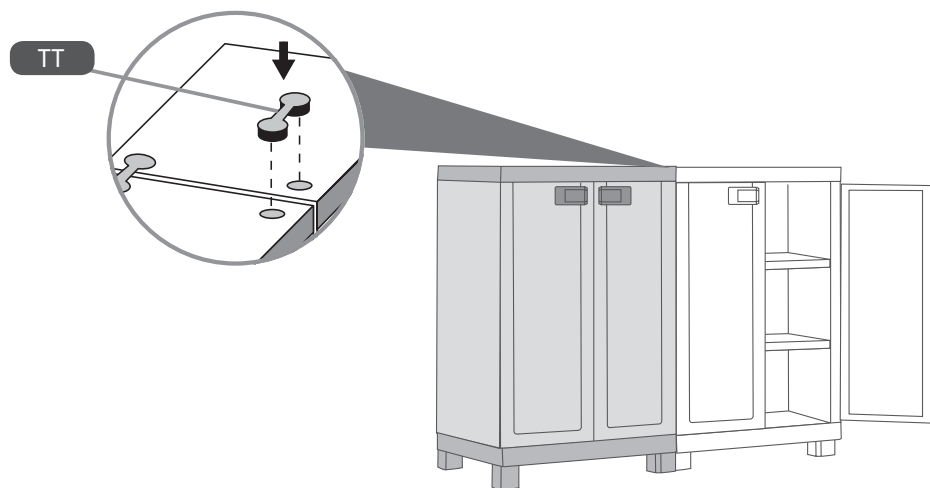
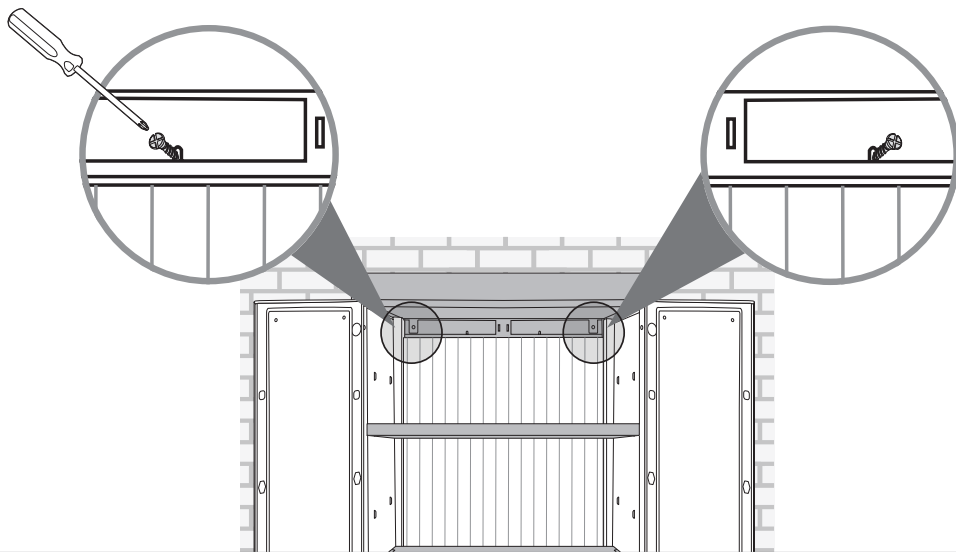

TRIBAC OPTION

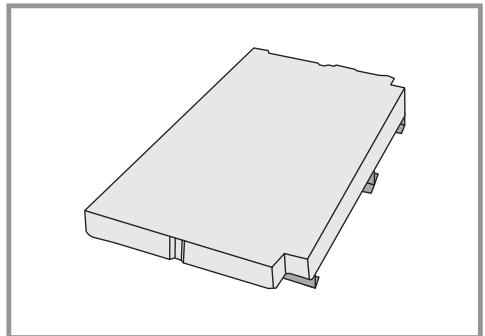
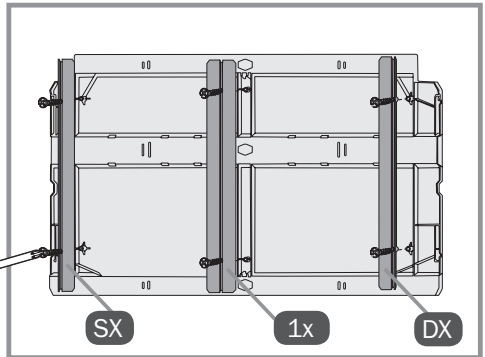
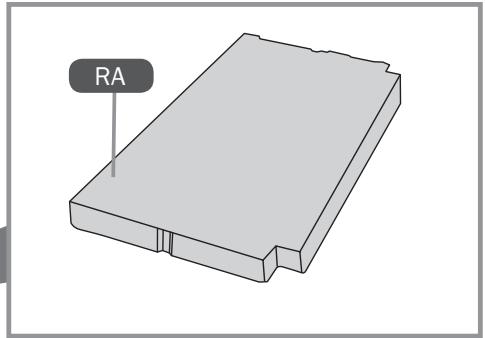
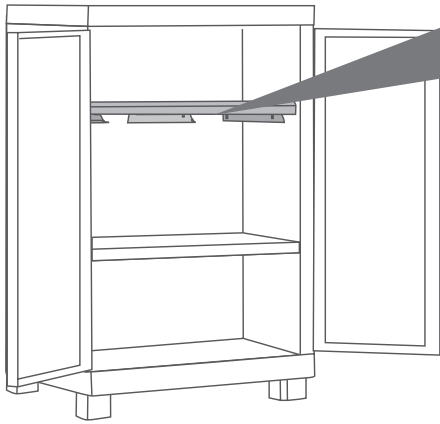

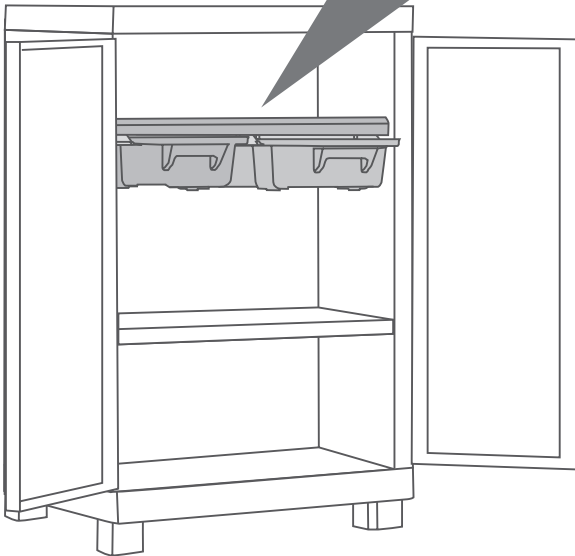
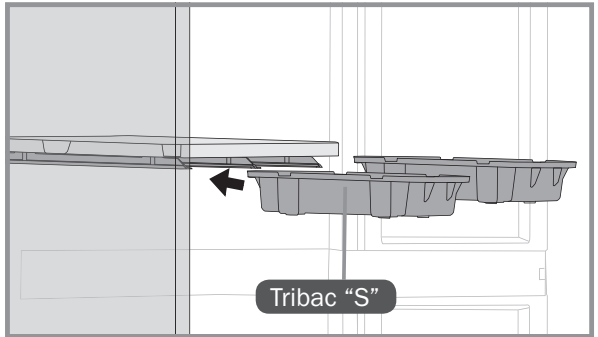

- I** Scatole Tribac "S" non incluse. **GB** Tribac "S" boxes not included. **D** Die Tribac "S"-Boxen sind nicht im Lieferumfang enthalten.
F Boîtes Tribac "S" non comprises. **E** Las cajas Tribac "S" no están incluidas. **NL** Dozen Tribac "S" niet inbegrepen.
TR Tribac "S" kutuları dahil değildir. **GR** Τα κουτιά Tribac "S" δεν συμπεριλαμβάνονται. **RUS** Коробки Tribac "S" не входят в набор.
RO Cutiile Tribac "S" nu sunt incluse. **CZ** Krabice Tribac "S" nejsou součástí balení. **PL** Pojemniki Tribac "S" niedostarczone.