



GS1100 Series

Unmanaged Gigabit Ethernet Switch

Version 1.00
Edition 5, 09/2015

User's Guide

IMPORTANT!

READ CAREFULLY BEFORE USE.

KEEP THIS GUIDE FOR FUTURE REFERENCE.

Screenshots and graphics in this book may differ slightly from your product due to differences in your product firmware or your computer operating system. Every effort has been made to ensure that the information in this manual is accurate.

- More Information

Go to **support.zyxel.com** to find other information on the Switch.



Table of Contents

Table of Contents	3
Chapter 1	
Getting to Know Your Switch	4
1.1 Introduction	4
1.2 Features	5
1.3 Applications	6
1.3.1 Standalone Workgroup	6
1.3.2 Bridging	6
1.4 Power Over Ethernet (PoE)	7
Chapter 2	
Hardware Description and Connection	8
2.1 Rear Panel	8
2.1.1 Rear Panel Power Connection	8
2.2 Front Panel	9
2.2.1 RJ-45 Auto-negotiating Ports	9
2.2.2 IEEE 802.3az EEE	9
2.2.3 SFP Slots (GS1100-24 and GS1100-10HP)	9
2.2.4 Front Panel Connections	11
2.2.5 Front Panel LEDs	11
2.3 Hardware Installation	14
2.3.1 Wall Mounting	14
2.3.2 Rack Mounting	15
2.3.3 Mounting the Switch on a Rack	16
Chapter 3	
Troubleshooting	18
3.1 Improper Network Cabling and Topology	19
Appendix A Legal Information.....	20
Index	29

Getting to Know Your Switch

1.1 Introduction

This chapter describes the key features, benefits and applications of your Switch.

This User's Guide covers the following models: GS1100-8HP, GS1100-16, GS1100-24, GS1100-24E and GS1100-10HP. The Switch is a 10/100/1000 Mbps multi-port switch that can be used to build high-performance switched workgroup networks. The Switch is a store-and-forward device that offers low latency for high-speed networking. The Switch is fanless and designed for workgroups, departments or backbone computing environments for small businesses.

Table 1 GS1100 Series Comparison Table

PORT/SWITCH DETAILS	GS1100-8HP	GS1100-16	GS1100-24	GS1100-24E	GS1100-10HP
10/100/1000Base-T Ethernet ports	8	16	24	24	8
100/1000Base-X SFP slots			2		2
802.3AT PoE ports	4				8
One physical IEEE 802.3az ON/OFF button	1	1	1	1	1
One power ON/OFF switch	1	1		1	1

The GS1100-8HP has four GbE PoE ports that can supply power to the connected PoE powered devices.

The GS1100-10HP has eight GbE PoE ports that can supply power to the connected PoE powered devices.

The GS1100-24 and GS1100-10HP have two SFP slots for uplink connection. Use SFP transceivers in these slots for 100Mbps or 1Gbps connections to backbone Ethernet switches.

The Switch has a built-in algorithm that automatically assigns priority to received packets. It can operate in low power idle mode in compliance with IEEE 802.3az Energy Efficient Ethernet (EEE).

Figure 1 Front Panel

GS1100-8HP



GS1100-16

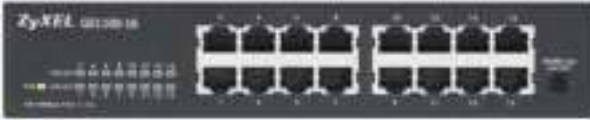

GS1100-24

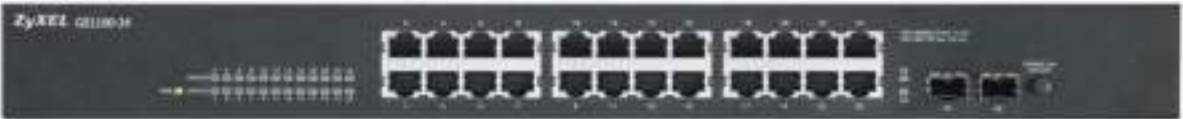

GS1100-24E

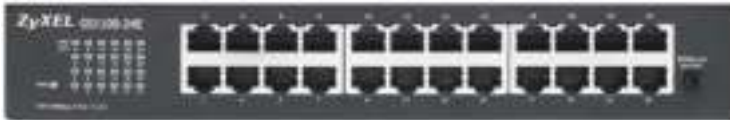

GS1100-10HP



1.2 Features

The following are the essential features of the Switch.

- Conforms to IEEE 802.3, 802.3u, 802.3ab and 802.3x standards.
- Auto-negotiating 10/100/1000 Mbps Gigabit Ethernet (GbE) RJ-45 ports.
- Auto-sensing crossover for all 10/100/1000 Mbps Gigabit Ethernet (GbE) RJ-45 ports.
- Supports N-Way protocol for speed (10/100/1000 Mbps) and duplex mode (Half/Full) auto-detection.
- Supports store-and-forward switching.
- Supports automatic address learning.
- Supports IEEE 802.3az EEE
- Supports IEEE 802.3af and IEEE 802.3at PoE standards (GS1100-8HP and GS1100-10HP)
- Full wire speed forwarding rate.
- Supports 802.1p CoS.
- Embedded 8K MAC address table providing 8000 MAC addresses entries.

1.3 Applications

This section provides two network topology examples in which the Switch is used.

1.3.1 Standalone Workgroup

In this application, the Switch is an ideal solution for small networks where rapid growth can be expected in the near future.

The Switch can be used standalone for a group of heavy traffic users. You can connect computers directly to the Switch's port or connect other switches to the Switch.

In this example, all computers can share high-speed applications on the server. To expand the network, simply add more networking devices such as switches, routers, computers, print servers etc.

Figure 2 Standalone Workgroup Example



1.3.2 Bridging

With its large address table and high performance, the Switch is an ideal solution for department networks to connect to the corporate backbone or for connecting network segments.

The following figure depicts a typical segment bridge application of the Switch in an enterprise environment. The two networks (**R&D** and **Sales**), the standalone server and the computers can all communicate with each other and share all network resources.

Figure 3 Bridging Example



1.4 Power Over Ethernet (PoE)

The PoE function is available for GS1100-8HP and GS1100-10HP.

Ports 1 to 4 on the GS1100-8HP are IEEE 802.3at High Power over Ethernet (PoE) compliant and can supply power of up to 30W per Ethernet port and up to the total PoE power budget per Switch.

Ports 1 to 8 on the GS1100-10HP support both the IEEE 802.3af Power over Ethernet and IEEE 802.3at High Power over Ethernet standards. The ports supply power of up to 30W per Ethernet port and up to the total PoE power budget per Switch.

The Switch is Power Sourcing Equipment (PSE) because it provides a source of power via its Ethernet ports. A powered device (PD) is a device such as an access point or an IP phone, that supports PoE (Power over Ethernet) so that it can receive power from another device through a 10/100/1000 Mbps Ethernet port.

In the figure below, the IP camera and IP phone get their power directly from the Switch. Aside from minimizing the need for cables and wires, PoE removes the hassle of trying to find a nearby electric outlet to power up devices.

Figure 4 Powered Device Examples



Hardware Description and Connection

2.1 Rear Panel

The power receptacle is located on the rear panel of the Switch. Refer to the power supply requirements on the panel.

Figure 5 Rear Panel

GS1100-8HP



GS1100-16



GS1100-24



GS1100-24E



GS1100-10HP



2.1.1 Rear Panel Power Connection

Connect one end of the supplied power cord or power adaptor to the power receptacle on the back of the Switch and the other end to the appropriate power source.

For the GS1100-8HP, GS1100-16, GS1100-24E and GS1100-10HP, use the **POWER ON/ OFF** switch to have the Switch power on or off.

2.2 Front Panel

The front panel of the Switch includes the auto-negotiating 10 Base-T/100 Base-TX/1000 Base-T RJ-45 ports and the LEDs.

The GS1100-24 and GS1100-10HP have two SFP slots. Refer to [Section 2.2.3 on page 9](#) for more information.

2.2.1 RJ-45 Auto-negotiating Ports

The 10 Base-T/100 Base-TX/1000 Base-T RJ-45 ports are auto-negotiating and auto-crossover.

An auto-negotiating port can detect and adjust to the optimum Ethernet speed (10/100/1000 Mbps) and duplex mode (full duplex or half duplex) of the connected device.

An auto-crossover (auto-MDI/MDI-X) port automatically works with a straight-through or crossover Ethernet cable.

2.2.2 IEEE 802.3az EEE

The Switch supports the IEEE 802.3az EEE (Energy Efficient Ethernet) standard to help reduce power consumption. This allows the Switch to go into power saving mode and switch off part of receive and transmit circuitry when it is not transmitting or receiving data through an Ethernet connection.

An EEE-enabled device initiates Low Power Idle (LPI) signals to negotiate and wake up the remote device when there is data to be transmitted. To use EEE, both devices should be EEE compliant.

EEE is configured on a per-system basis in the Switch. If one of the networking devices that connect to the Switch doesn't support EEE, EEE may not work in the Switch to save power.

Press in the **IEEE 802.3az EEE ON/ OFF** button on the front panel to turn on the EEE feature. Disable it if you don't want the network performance to be impacted due to the latency from the additional time required for the sleep and wake transition or if the remote side doesn't support it.

2.2.3 SFP Slots (GS1100-24 and GS1100-10HP)

These are slots for Small Form-factor Pluggable (SFP) transceivers. A transceiver is a single unit that houses a transmitter and a receiver. The Switch does not come with transceivers. You must use transceivers that comply with the Small Form-factor Pluggable (SFP) Transceiver MultiSource Agreement (MSA). See the SFF committee's INF-8074i specification Rev 1.0 for details.

You can change transceivers while the Switch is operating. You can use different transceivers to connect to Ethernet switches with different types of fiber-optic or even copper cable connectors.

To avoid possible eye injury, do not look into an operating fiber-optic module's connectors.

- Type: SFP connection interface
- Connection speed: 100 Megabit per second (Mbps) or 1 Gigabit per second (Gbps)

2.2.3.1 Transceiver Installation

Use the following steps to install a SFP module.

- 1 Insert the transceiver into the slot with the exposed section of PCB board facing down.
- 2 Press the transceiver firmly until it clicks into place.
- 3 The Switch automatically detects the installed transceiver. Check the LEDs to verify that it is functioning properly.
- 4 Close the transceiver's latch (latch styles vary).
- 5 Connect the fiber optic cables to the transceiver.

Figure 6 Transceiver Installation Example

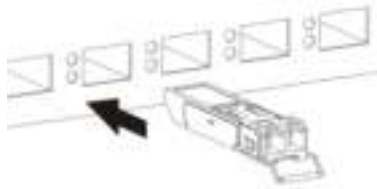
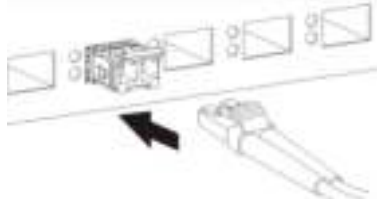

Figure 7 Connecting the Fiber Optic Cables



2.2.3.2 Transceiver Removal

Use the following steps to remove a SFP module.

- 1 Remove the fiber optic cables from the transceiver.
- 2 Open the transceiver's latch (latch styles vary).
- 3 Pull the transceiver out of the slot.

Figure 8 Removing the Fiber Optic Cables

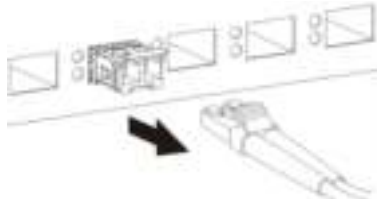
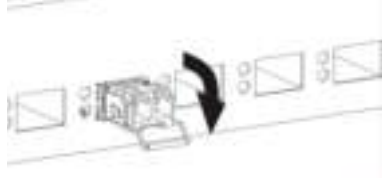
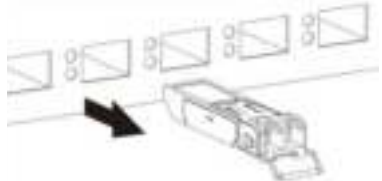

Figure 9 Opening the Transceiver's Latch Example**Figure 10** Transceiver Removal Example

2.2.4 Front Panel Connections

You can use unshielded twisted pair (UTP) or shielded twisted-pair (STP) Ethernet cables for RJ-45 ports. The following table describes the types of network cable used for the different connection speeds. .

Table 2 Network Cable Types

SPEED	NETWORK CABLE TYPE
10 Mbps	Category 3, 4 or 5 UTP/STP
100 Mbps	Category 5 UTP/STP
1000 Mbps	Category 5e, 6 UTP/STP

You can use either crossover or straight-through cables for all the ports.

2.2.5 Front Panel LEDs

The LED Indicators give real-time information about the status of the Switch. The following table provides descriptions of the LEDs.

Figure 11 Front Panel LEDs

GS1100-8HP



GS1100-16



GS1100-24

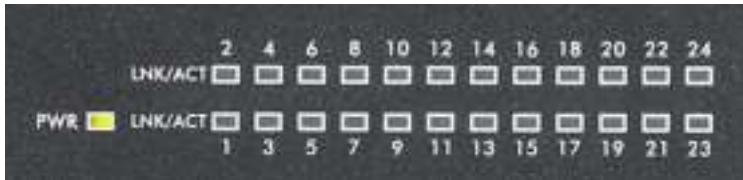

GS1100-24E

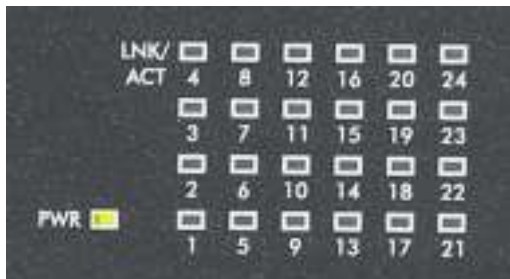

GS1100-10HP



The following table describes the LEDs.

Table 3 The Front Panel LED Descriptions: GS1100-8HP

LED	COLOR	STATUS	DESCRIPTION
PWR	Green	On	The Switch is on and receiving power.
		Off	The Switch is not receiving power.
PoE MAX	Red	On	Power supplied to the PoE port(s) reaches the power budget limit or exceeds the total PoE power budget on the Switch.
		Off	Power supplied to the PoE port(s) is below the power budget limit.

Table 3 The Front Panel LED Descriptions: GS1100-8HP

LED	COLOR	STATUS	DESCRIPTION
PoE	Amber	On	Power is supplied to the PoE port.
		Off	Power is not supplied to the PoE port.
1G	Green	On	The port is connected to an Ethernet network at 1000M speed.
		Blinking	The port is receiving or transmitting data at 1000M speed.
		Off	The port is not connected to an Ethernet network.
10/100	Amber	On	The port is connected to an Ethernet network at 10M or 100M speed.
		Blinking	The port is receiving or transmitting data at 10M or 100M speed.
		Off	The port is not connected to an Ethernet network.

Table 4 The Front Panel LED Descriptions: GS1100-16/24/24E

LED	COLOR	STATUS	DESCRIPTION
PWR	Green	On	The Switch is on and receiving power.
		Off	The Switch is not receiving power.
LINK/ ACT	Green	On	The port is connected to an Ethernet network.
		Blinking	The port is receiving or transmitting data.
		Off	The port is not connected to an Ethernet network.

Table 5 The Front Panel LED Descriptions: GS1100-10HP

LED	COLOR	STATUS	DESCRIPTION
PWR	Green	On	The Switch is on and receiving power.
		Off	The Switch is not receiving power.
PoE MAX	Amber	On	Power supplied to the PoE port(s) has reached ninety-five percent of the power budget limit or has exceeded the total PoE power budget on the Switch.
		Off	Power supplied to the PoE port(s) is below the power budget limit.
PoE 10/100/1000Base-T Ports			
Link/ACT (Left)	Green	On	The port is connected to an Ethernet network at 1 Gbps.
		Blinking	The port is receiving or transmitting data at 1 Gbps.
		Off	The port is not connected to an Ethernet network.
	Amber	On	The port is connected to an Ethernet network at 10/100 Mbps.
		Blinking	The port is receiving or transmitting data at 10/100 Mbps.
		Off	The port is not connected to an Ethernet network.
PoE Mode (Right)	Green	On	Power supplied to the PoE port(s) complies with the IEEE 802.3at.
		Off	Power supplied to the PoE port(s) is not exported.
	Amber	On	Power supplied to the PoE port(s) complies with the IEEE 802.3af.
		Off	Power supplied to the PoE port(s) is not exported.
SFP	Green	On	The port is connected to an Ethernet network at 1 Gbps.
		Blinking	The port is receiving or transmitting data at 1 Gbps.
		Off	The port is not connected to an Ethernet network.
	Amber	On	The port is connected to an Ethernet network at 100 Mbps.
		Blinking	The port is receiving or transmitting data at 100 Mbps.
		Off	The port is not connected to an Ethernet network.

2.3 Hardware Installation

See the following table for a comparison of the hardware installation methods of each GS1100 model:

Table 6 GS1100 Series Installation Comparison Table

MODEL FEATURE	GS1100-8HP	GS1100-16	GS1100-24	GS1100-24E	GS1100-10HP
Desktop Device	✓	✓		✓	✓
Wall-mountable	✓	✓		✓	✓
Rack-mountable		✓	✓	✓	

Note: Ask an authorized technician to attach the Switch to the rack/wall.

For GS1100-8HP, GS1100-16, GS1100-24E and GS1100-10HP, you can place the Switch directly on top of your desk or have it wall-mounted. For GS1100-16, GS1100-24 and GS1100-24E, the size is suitable for rack-mounting and you can refer to [Section 2.3.2 on page 15](#) for instruction. Take note of the following:

- The Switch should have a minimum 25 mm space around it for ventilation.
- The Switch should be placed in a desk that has a level surface and that is able to support the weight of the Switch.

To start using it, simply connect the power cables and turn on the Switch.

2.3.1 Wall Mounting

Do the following to attach your Switch to a wall.

See [Table 7 on page 14](#) for how far apart to place the screws.

Table 7 Distance between the centers of the holes for wall mounting

MODEL	DISTANCE
GS1100-8HP	120 mm
GS1100-16	148 mm
GS1100-24E	207 mm
GS1100-10HP	176mm

- 1 Screw the two screws provided with your Switch into the wall (see the figure in step 2). Use screws with 6 mm ~ 8 mm (0.24" ~ 0.31") wide heads. Do not screw the screws all the way in to the wall; leave a small gap between the head of the screw and the wall.

The gap must be big enough for the screw heads to slide into the screw slots and the connection cables to run down the back of the Switch.

Note: Make sure the screws are securely fixed to the wall and strong enough to hold the weight of the Switch with the connection cables.

- 2 Align the holes on the back of the Switch with the screws on the wall. Hang the Switch on the screws.

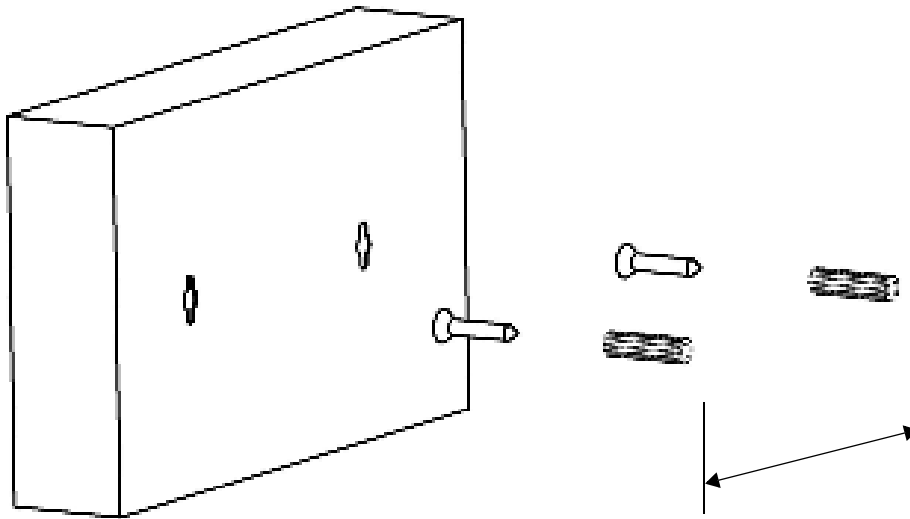

The Switch should be wall-mounted horizontally. The Switch's side panels with ventilation slots should not be facing up or down as this position is less safe.

2.3.2 Rack Mounting

The Switch can be mounted on an EIA standard size, 19-inch rack or in a wiring closet with other equipment. Follow the steps below to mount your Switch on a standard EIA rack using a rack-mounting kit.

Rack-mounted Installation Requirements

- Two mounting brackets.
- Eight M3 flat head screws and a #2 Philips screwdriver.
- Four M5 flat head screws and a #2 Philips screwdriver.

Failure to use the proper screws may damage the unit.

Precautions

- Make sure the rack will safely support the combined weight of all the equipment it contains.
- Make sure the position of the Switch does not make the rack unstable or top-heavy. Take all necessary precautions to anchor the rack securely before installing the unit.

Attaching the Mounting Brackets to the Switch

- 1 Position a mounting bracket on one side of the Switch, lining up the four screw holes on the bracket with the screw holes on the side of the Switch.

Figure 12 Attaching the Mounting Brackets (GS1100-16 and GS1100-24E)

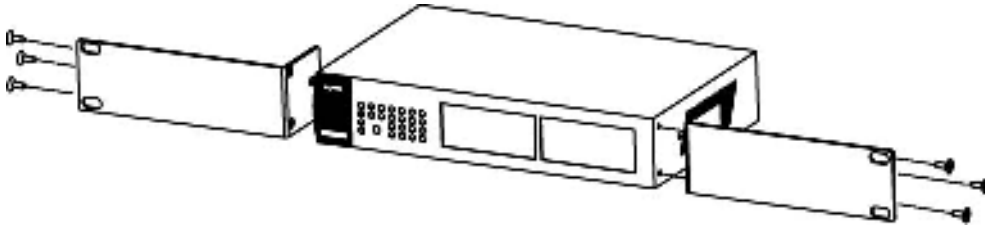
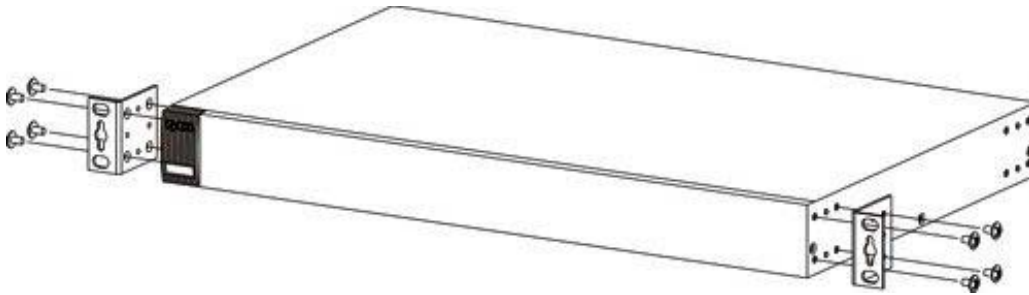

Figure 13 Attaching the Mounting Brackets (GS1100-24)



- 2 Using a #2 Philips screwdriver, install the M3 flat head screws through the mounting bracket holes into the Switch.
- 3 Repeat steps 1 and 2 to install the second mounting bracket on the other side of the Switch.
- 4 You may now mount the Switch on a rack. Proceed to the next section.

2.3.3 Mounting the Switch on a Rack

- 1 Position a mounting bracket (that is already attached to the Switch) on one side of the rack, lining up the two screw holes on the bracket with the screw holes on the side of the rack.

Figure 14 Mounting the Switch on a Rack (GS1100-16 and GS1100-24E)

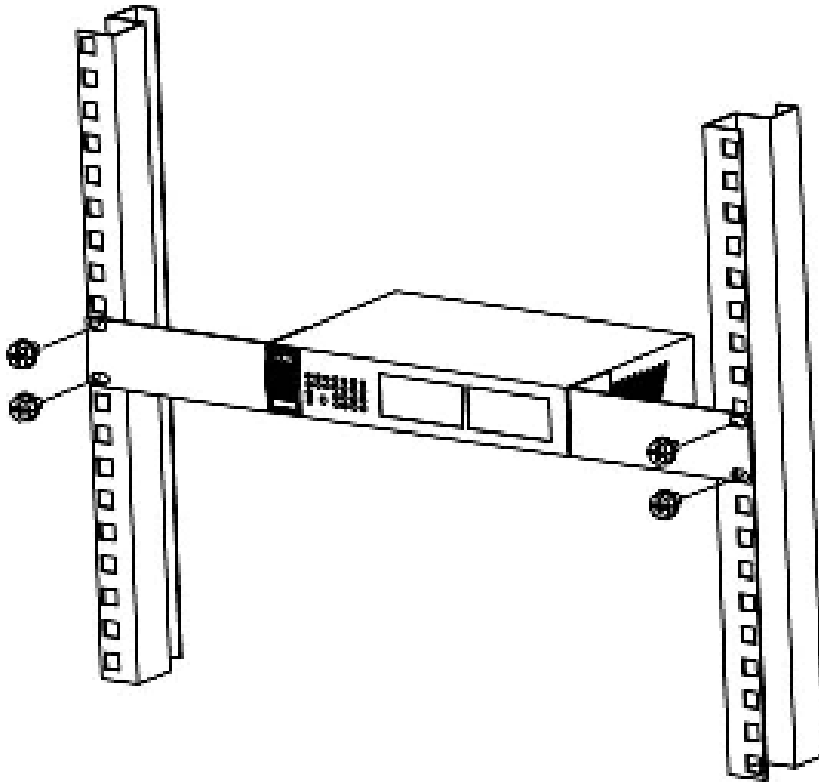
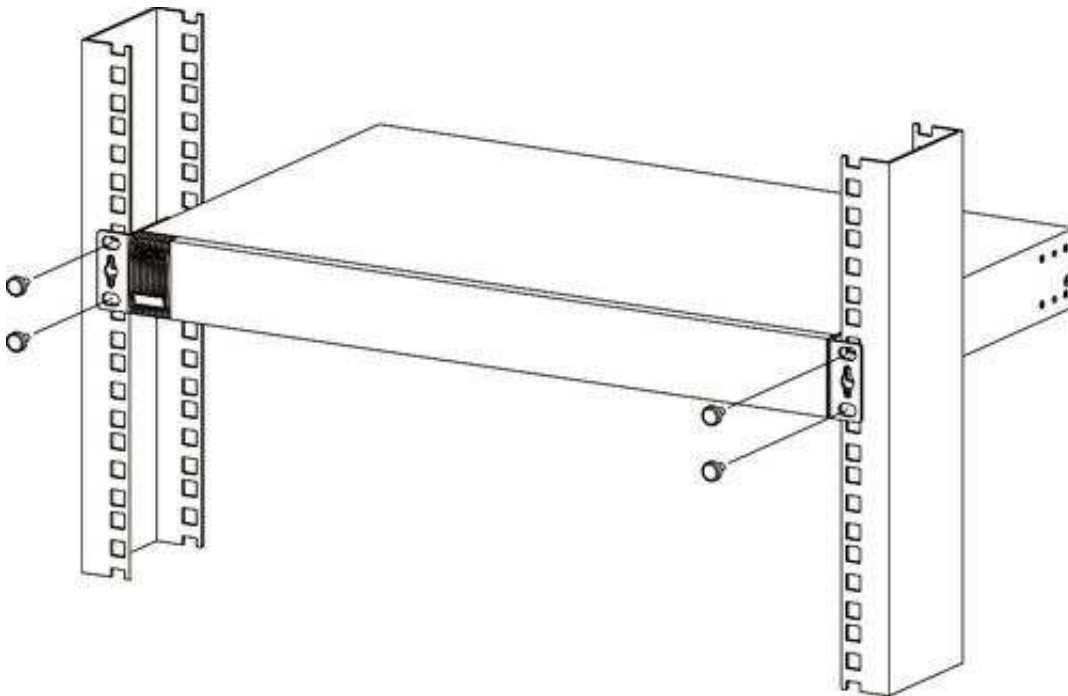

Figure 15 Mounting the Switch on a Rack (GS1100-24)



- 2 Using a #2 Philips screwdriver, install the M5 flat head screws through the mounting bracket holes into the rack.
- 3 Repeat steps 1 and 2 to attach the second mounting bracket on the other side of the rack.

Troubleshooting

This section describes common problems you may encounter with the Switch and possible solutions.

Troubleshoot the Switch using the LEDs to detect problems.

The **PWR** LED on the front panel does not light up.

- Check the connections from your Switch to the power source. Make sure you are using the supplied power cord and that you are using an appropriate power source. Refer to the product specifications.
- Make sure the power source is turned on and that the Switch is receiving sufficient power.
- If these steps fail to correct the problem, contact your local distributor for assistance.

The **LNK/ ACT**, **1G** or **10/ 100** LED does not light up when a device is connected.

- Verify that the attached device(s) is turned on and properly connected to your Switch.
- Make sure the network adapters are working on the attached devices.
- Verify that proper network cable type is used and its length does not exceed 100 meters. For more information on network cable types, see [Section 3.1 on page 19](#).

The **PoE** LED is off and/or power is not being supplied to my PoE-enabled device. (For GS1100-8HP and GS1100-10HP)

- Check to see that the power adaptor is securely connected to the GS1100-8HP (or GS1100-10HP) and an appropriate power source. Make sure the power source is on and functioning properly.
- Check that the Ethernet cables are connected properly and that you are using the correct type of Ethernet cable. Contact your local distributor if the problem persists.

3.1 Improper Network Cabling and Topology

Improper network cabling or topology setup is a common cause of poor network performance or even network failure.

Figure 16 Troubleshooting Improper Network Cabling and Topology

PROBLEM	CORRECTIVE ACTION
Faulty cables	Using faulty network cables may affect data rates and have an impact on your network performance. Replace with new standard network cables.
Non-standard network cables	Non-standard cables may increase the number of network collisions and cause other network problems that affect your network performance. Refer to Section 2.2.4 on page 11 for more information on network cable types.
Cabling Length	If you use longer cables than are needed, transmission quality may be affected. The network cables should not be longer than the limit of 100 meters.
Too many hubs between the computers in the network	Too many hubs (or repeaters) between the connected computers in the network may increase the number of network collision or other network problems. Remove unnecessary hubs from the network.
A loop in the data path	A data path loop forms when there is more than one path or route between two networked computers. This results in broadcast storms that will severely affect your network performance. Make sure there are no loops in your network topology.

Legal Information

Copyright

Copyright © 2015 by ZyXEL Communications Corporation.

The contents of this publication may not be reproduced in any part or as a whole, transcribed, stored in a retrieval system, translated into any language, or transmitted in any form or by any means, electronic, mechanical, magnetic, optical, chemical, photocopying, manual, or otherwise, without the prior written permission of ZyXEL Communications Corporation.

Published by ZyXEL Communications Corporation. All rights reserved.

Disclaimer

ZyXEL does not assume any liability arising out of the application or use of any products, or software described herein. Neither does it convey any license under its patent rights nor the patent rights of others. ZyXEL further reserves the right to make changes in any products described herein without notice. This publication is subject to change without notice.

Regulatory Notice and Statement (Class A)

Model List: GS1100-8HP, GS1100-24

United States of America



Federal Communications Commission (FCC) EMC Statement

- This device complies with Part 15 of FCC rules. Operation is subject to the following two conditions:
 - (1) This device may not cause harmful interference.
 - (2) This device must accept any interference received, including interference that may cause undesired operations.
- Changes or modifications not expressly approved by the party responsible for compliance could void the user's authority to operate the equipment.
- This equipment has been tested and found to comply with the limits for a Class A digital device, pursuant to part 15 of the FCC Rules. These limits are designed to provide reasonable protection against harmful interference when the equipment is operated in a commercial environment. This equipment generates, uses, and can radiate radio frequency energy and, if not installed and used in accordance with the instruction manual, may cause harmful interference to radio communications. Operation of this equipment in a residential area is likely to cause harmful interference in which case the user will be required to correct the interference at his own expense.

Canada

The following information applies if you use the product within Canada area

Industry Canada ICES statement

CAN ICES-3 (A)/NMB-3(A)

European Union



The following information applies if you use the product within the European Union.

CE EMC statement

This is Class A Product. In domestic environment this product may cause radio interference in which case the user may be required to take adequate measures.

List of National Codes

COUNTRY	ISO 3166 2 LETTER CODE	COUNTRY	ISO 3166 2 LETTER CODE
Austria	AT	Malta	MT
Belgium	BE	Netherlands	NL
Cyprus	CY	Poland	PL
Czech Republic	CR	Portugal	PT
Denmark	DK	Slovakia	SK
Estonia	EE	Slovenia	SI
Finland	FI	Spain	ES
France	FR	Sweden	SE
Germany	DE	United Kingdom	GB
Greece	GR	Iceland	IS
Hungary	HU	Liechtenstein	LI
Ireland	IE	Norway	NO
Italy	IT	Switzerland	CH
Latvia	LV	Bulgaria	BG
Lithuania	LT	Romania	RO
Luxembourg	LU	Turkey	TR

Notices

CLASS 1 LASER PRODUCT
 APPAREIL À LASER DE CLASS 1
 PRODUCT COMPLIES WITH 21 CFR 1040.10 AND 1040.11.
 PRODUIT CONFORME SELON 21 CFR 1040.10 ET 1040.11.

Safety Warnings

- Do NOT use this product near water, for example, in a wet basement or near a swimming pool.
- Do NOT expose your device to dampness, dust or corrosive liquids.
- Do NOT store things on the device.
- Do NOT install, use, or service this device during a thunderstorm. There is a remote risk of electric shock from lightning.
- Connect ONLY suitable accessories to the device.
- Do NOT open the device or unit. Opening or removing covers can expose you to dangerous high voltage points or other risks. ONLY qualified service personnel should service or disassemble this device. Please contact your vendor for further information.
- Make sure to connect the cables to the correct ports.
- Place connecting cables carefully so that no one will step on them or stumble over them.
- Always disconnect all cables from this device before servicing or disassembling.
- Use ONLY an appropriate power adaptor or cord for your device. Connect it to the right supply voltage (for example, 110V AC in North America or 230V AC in Europe).
- Do NOT remove the plug and connect it to a power outlet by itself; always attach the plug to the power adaptor first before connecting it to a power outlet.
- Do NOT allow anything to rest on the power adaptor or cord and do NOT place the product where anyone can walk on the power adaptor or cord.
- Do NOT use the device if the power adaptor or cord is damaged as it might cause electrocution.
- If the power adaptor or cord is damaged, remove it from the device and the power source.
- Do NOT attempt to repair the power adaptor or cord. Contact your local vendor to order a new one.
- Do not use the device outside, and make sure all the connections are indoors. There is a remote risk of electric shock from lightning.
- CAUTION: RISK OF EXPLOSION IF BATTERY (on the motherboard) IS REPLACED BY AN INCORRECT TYPE. DISPOSE OF USED BATTERIES ACCORDING TO THE INSTRUCTIONS. Dispose them at the applicable collection point for the recycling of electrical and electronic equipment. For detailed information about recycling of this product, please contact your local city office, your household waste disposal service or the store where you purchased the product.
- Do NOT obstruct the device ventilation slots, as insufficient airflow may harm your device.
- Antenna Warning! This device meets ETSI and FCC certification requirements when using the included antenna(s). Only use the included antenna(s).
- If you wall mount your wall-mountable device, make sure that no electrical lines, gas or water pipes will be damaged.

The following warnings apply if product is disconnect device:

- A readily accessible disconnect device shall be incorporated external to the equipment; and/or

The socket-outlet shall be installed near the equipment and shall be easily accessible.

WEEE Directive

Your product is marked with this symbol, which is known as the WEEE mark. WEEE stands for Waste Electronics and Electrical Equipment. It means that used electrical and electronic products should not be mixed with general waste. Used electrical and electronic equipment should be treated separately.

Die folgende Symbol bedeutet, dass Ihr Produkt und/oder seine Batterie gemäß den örtlichen Bestimmungen getrennt vom Hausmüll entsorgt werden muss. Wenden Sie sich an eine Recyclingstation, wenn dieses Produkt das Ende seiner Lebensdauer erreicht hat. Zum Zeitpunkt der Entsorgung wird die getrennte Sammlung von Produkt und/oder seiner Batterie dazu beitragen, natürliche Ressourcen zu sparen und die Umwelt und die menschliche Gesundheit zu schützen.

El símbolo de abajo indica que según las regulaciones locales, su producto y/o su batería deberán depositarse como basura separada de la doméstica. Cuando este producto alcance el final de su vida útil, llévelo a un punto limpio. Cuando llegue el momento de desechar el producto, la recogida por separado éste y/o su batería ayudará a salvar los recursos naturales y a proteger la salud humana y medioambiental.

Le symbole ci-dessous signifie que selon les réglementations en vigueur votre produit et/ou sa batterie doivent être éliminés séparément des ordures ménagères. Lorsque ce produit atteint sa fin de vie, amenez-le à un centre de recyclage pour qu'il soit mis au rebut. La collecte séparée de votre produit et/ou de sa batterie permettra une meilleure protection de l'environnement et de la santé humaine.

Questo simbolo significa che secondo i regolamenti locali il prodotto e/o la sua batteria devono essere trattati separatamente dai rifiuti domestici. Quando questo prodotto raggiunge la fine della vita di servizio portatelo ad una stazione di riciclaggio. Questo trattamento separato del prodotto e/o della sua batteria aiuta a risparmiare risorse naturali e a proteggere l'ambiente.

Symbolen innebär att enligt lokal lagstiftning ska produkten och/eller dess batteri kastas separat från hushållsavfallet. När den här produkten når slutet av sin livslängd ska du ta den till en återvinningsstation. Separat insamling av din produkt och / eller dess batteri hjälper till att både spara naturresurser och se till att miljön når en hållbar utveckling.



Environmental Product Declaration

Bulgarian (Bulgarian)	Čeština (Czech)	Dansk (Danish)	Deutsch (German)
<p>Environmental product declaration</p> <p>RoHS Directive 2011/65/EU WEEE Directive 2012/19/EU PFW Directive 94/62/EC REACH Regulation (EC) n° 1907/2006</p> <p>Name: Richard Heu / Quality Management Title: Director Service Manager Signature: [Signature] Date: 01/10/2014</p>	<p>Environmentální prohlášení o produktu</p> <p>RoHS Směrnice 2011/65/EU WEEE Směrnice 2012/19/EU PPW Směrnice 94/62/EC REACH Nařízení (ES) č. 1907/2006</p> <p>Jméno: Richard Heu / Quality Management Titul: Director Service Manager Podpis: [Signature] Datum: 01/10/2014</p>	<p>Miljøerklæring</p> <p>RoHS Direktiv 2011/65/EU WEEE Direktiv 2012/19/EU PPW Direktiv 94/62/EC REACH Forordning (EF) nr. 1907/2006</p> <p>Navn: Richard Heu / Quality Management Titel: Director Service Manager Underskrift: [Signature] Dato: 01/10/2014</p>	<p>Produkt-Umweltdeklaration</p> <p>RoHS Richtlinie 2011/65/EU WEEE Richtlinie 2012/19/EU PPW Richtlinie 94/62/EC REACH VO/REGULATON (EG) Nr. 1907/2006</p> <p>Name: Richard Heu / Quality Management Titel: Director Service Manager Unterschrift: [Signature] Datum: 01/10/2014</p>
<p>Environmental product declaration</p> <p>RoHS Směrnice 2011/65/EU WEEE Směrnice 2012/19/EU PPW Směrnice 94/62/EC REACH Nařízení (ES) n° 1907/2006</p> <p>Name: Richard Heu / Quality Management Title: Director Service Manager Signature: [Signature] Date: 01/10/2014</p>	<p>Environmental product declaration</p> <p>RoHS Směrnice 2011/65/EU WEEE Směrnice 2012/19/EU PPW Směrnice 94/62/EC REACH Nařízení (ES) n° 1907/2006</p> <p>Name: Richard Heu / Quality Management Title: Director Service Manager Signature: [Signature] Date: 01/10/2014</p>	<p>Declaración Ambiental de Producto</p> <p>RoHS Directiva 2011/65/EU WEEE Directiva 2012/19/EU PPW Directiva 94/62/EC REACH REGULAMENTO (CE) n° 1907/2006</p> <p>Nombre: Richard Heu / Quality Management Cargo: Director Service Manager Firma: [Signature] Fecha: 01/10/2014</p>	<p>Profil environnemental de produit</p> <p>RoHS Directive 2011/65/EU WEEE Directive 2012/19/EU PPW Directive 94/62/EC REACH REGULATION (EC) n° 1907/2006</p> <p>Name: Richard Heu / Quality Management Title: Director Service Manager Signature: [Signature] Date: 01/10/2014</p>
<p>Environmental product declaration</p> <p>RoHS Směrnice 2011/65/EU WEEE Směrnice 2012/19/EU PPW Směrnice 94/62/EC REACH Nařízení (ES) n° 1907/2006</p> <p>Name: Richard Heu / Quality Management Title: Director Service Manager Signature: [Signature] Date: 01/10/2014</p>	<p>Declaración ambiental de producto</p> <p>RoHS Directiva 2011/65/EU WEEE Directiva 2012/19/EU PPW Directiva 94/62/EC REACH REGULAMENTO (CE) n° 1907/2006</p> <p>Nombre: Richard Heu / Quality Management Cargo: Director Service Manager Firma: [Signature] Fecha: 01/10/2014</p>	<p>Produkta vides apliecinājuma deklarācija</p> <p>RoHS Direktīva 2011/65/EU WEEE Direktīva 2012/19/EU PPW Direktīva 94/62/EC REACH Regula (ES) Nr. 1907/2006</p> <p>Personas Vārds: Richard Heu / Quality Management Amatsvārds: Director Service Manager Paraksts: [Signature] Datums: 01/10/2014</p>	<p>Apliecinājuma gaisma deklarācija</p> <p>RoHS Direktīva 2011/65/EU WEEE Direktīva 2012/19/EU PPW Direktīva 94/62/EC REACH REGULAMENTO (CE) n° 1907/2006</p> <p>Nombre: Richard Heu / Quality Management Title: Director Service Manager Signature: [Signature] Date: 01/10/2014</p>
<p>Environmental product declaration</p> <p>RoHS Směrnice 2011/65/EU WEEE Směrnice 2012/19/EU PPW Směrnice 94/62/EC REACH Nařízení (ES) n° 1907/2006</p> <p>Name: Richard Heu / Quality Management Title: Director Service Manager Signature: [Signature] Date: 01/10/2014</p>	<p>Declaración ambiental de producto</p> <p>RoHS Directiva 2011/65/EU WEEE Directiva 2012/19/EU PPW Directiva 94/62/EC REACH REGULAMENTO (CE) n° 1907/2006</p> <p>Nombre: Richard Heu / Quality Management Cargo: Director Service Manager Firma: [Signature] Fecha: 01/10/2014</p>	<p>Miljøproduktdeklaring</p> <p>RoHS Direktiv 2011/65/EU WEEE Direktiv 2012/19/EU PPW Direktiv 94/62/EC REACH Forordning (EF) nr. 1907/2006</p> <p>Navn: Richard Heu / Quality Management Titel: Director Service Manager Underskrift: [Signature] Dato: 01/10/2014</p>	<p>Deklaracja środowiskowa produktu</p> <p>RoHS Dyrektywa 2011/65/EU WEEE Dyrektywa 2012/19/EU PPW Dyrektywa 94/62/EC REACH Rozporządzenie (WE) nr. 1907/2006</p> <p>Nazwisko: Richard Heu / Quality Management Titel: Director Service Manager Podpis: [Signature] Data: 01/10/2014</p>
<p>Environmental product declaration</p> <p>RoHS Směrnice 2011/65/EU WEEE Směrnice 2012/19/EU PPW Směrnice 94/62/EC REACH Nařízení (ES) n° 1907/2006</p> <p>Name: Richard Heu / Quality Management Title: Director Service Manager Signature: [Signature] Date: 01/10/2014</p>	<p>Declaración ambiental de producto</p> <p>RoHS Directiva 2011/65/EU WEEE Directiva 2012/19/EU PPW Directiva 94/62/EC REACH REGULAMENTO (CE) n° 1907/2006</p> <p>Nombre: Richard Heu / Quality Management Cargo: Director Service Manager Firma: [Signature] Fecha: 01/10/2014</p>	<p>Vyhlašení o environmentálním výrobku</p> <p>RoHS Směrnice 2011/65/EU WEEE Směrnice 2012/19/EU PPW Směrnice 94/62/EC REACH Nařízení (ES) č. 1907/2006</p> <p>Jméno: Richard Heu / Quality Management Titel: Director Service Manager Podpis: [Signature] Datum: 01/10/2014</p>	<p>Okoljoko deklaracija izdelka</p> <p>RoHS Direktiva 2011/65/EU WEEE Direktiva 2012/19/EU PPW Direktiva 94/62/EC REACH Smleba (ES) n° 1907/2006</p> <p>Ime: Richard Heu / Quality Management Titel: Director Service Manager Podpis: [Signature] Datum: 01/10/2014</p>
<p>Environmental product declaration</p> <p>RoHS Směrnice 2011/65/EU WEEE Směrnice 2012/19/EU PPW Směrnice 94/62/EC REACH Nařízení (ES) n° 1907/2006</p> <p>Name: Richard Heu / Quality Management Title: Director Service Manager Signature: [Signature] Date: 01/10/2014</p>	<p>Miljöproduktdeklaration</p> <p>RoHS Direktiv 2011/65/EU WEEE Direktiv 2012/19/EU PPW Direktiv 94/62/EC REACH Förordning (EG) nr. 1907/2006</p> <p>Navn: Richard Heu / Quality Management Titel: Director Service Manager Underskrift: [Signature] Datum: 01/10/2014</p>	<p>Περιβαλλοντική δήλωση προϊόντος</p> <p>RoHS Οδηγία 2011/65/ΕΕ WEEE Οδηγία 2012/19/ΕΕ PPW Οδηγία 94/62/ΕΕ REACH Κανονισμός (ΕΕ) αριθ. 1907/2006</p> <p>Όνομα: Richard Heu / Quality Management Titel: Director Service Manager Υπογραφή: [Signature] Ημερομηνία: 01/10/2014</p>	<p>Miljøerklæring</p> <p>RoHS Direktiv 2011/65/EU WEEE Direktiv 2012/19/EU PPW Direktiv 94/62/EC REACH Forordning (EF) nr. 1907/2006</p> <p>Navn: Richard Heu / Quality Management Titel: Director Service Manager Signature: [Signature] Date: 01/10/2014</p>

台灣

以下訊息僅適用於產品銷售至台灣地區

這是甲類的資訊產品，在居住的環境中使用時，可能會造成射頻干擾，在這種情況下，使用者會被要求採取某些適當的對策。

安全警告

為了您的安全，請先閱讀以下警告及指示：

- 請勿將此產品接近水、火焰或放置在高溫的環境。
- 避免設備接觸
 - 任何液體 - 切勿讓設備接觸水、雨水、高濕度、污水腐蝕性的液體或其他水份。
 - 灰塵及污物 - 切勿接觸灰塵、污物、沙土、食物或其他不合適的材料。
 - 切勿重摔或撞擊設備，並勿使用不正確的電源變壓器。
- 若接上不正確的電源變壓器會有爆炸的風險。
 - 請勿隨意更換產品內的電池。
 - 如果更換不正確之電池型式，會有爆炸的風險，請依製造商說明書處理使用過之電池。
 - 請將廢電池丟棄在適當的電器或電子設備回收處。
 - 請勿將設備解體。
 - 請勿阻礙設備的散熱孔，空氣對流不足將會造成設備損害。
 - 請插在正確的電壓供給插座（如：北美/台灣電壓 110V AC，歐洲是 230V AC）。
 - 假若電源變壓器或電源變壓器的纜線損壞，請從插座拔除，若您還繼續插電使用，會有觸電死亡的風險。
 - 請勿試圖修理電源變壓器或電源變壓器的纜線，若有毀損，請直接聯絡您購買的店家，購買一個新的電源變壓器。
 - 請勿將此設備安裝於室外，此設備僅適合放置於室內。
 - 請勿隨一般垃圾丟棄。
 - 請參閱產品背貼上的設備額定功率。
 - 請參考產品型錄或是彩盒上的作業溫度。

Regulatory Notice and Statement (Class B)

Model List: GS1100-10HP, GS1100-16, GS1100-24E

United States of America



Federal Communications Commission (FCC) EMC Statement

- This device complies with Part 15 of FCC rules. Operation is subject to the following two conditions:
 - (1) This device may not cause harmful interference.
 - (2) This device must accept any interference received, including interference that may cause undesired operations.
- Changes or modifications not expressly approved by the party responsible for compliance could void the user's authority to operate the equipment.
- This product has been tested and complies with the specifications for a Class B digital device, pursuant to Part 15 of the FCC Rules. These limits are designed to provide reasonable protection against harmful interference in a residential installation. This equipment generates, uses, and can radiate radio frequency energy and, if not installed and used according to the instructions, may cause harmful interference to radio communications. However, there is no guarantee that interference will not occur in a particular installation.
- If this equipment does cause harmful interference to radio or television reception, which is found by turning the equipment off and on, the user is encouraged to try to correct the interference by one or more of the following measures:
 - Reorient or relocate the receiving antenna
 - Increase the separation between the equipment or devices
 - Connect the equipment to an outlet other than the receiver's
 - Consult a dealer or an experienced radio/TV technician for assistance

Canada

The following information applies if you use the product within Canada area

Industry Canada ICES statement

CAN ICES-3 (B)/NMB-3(B)

List of National Codes

COUNTRY	ISO 3166 2 LETTER CODE	COUNTRY	ISO 3166 2 LETTER CODE
Austria	AT	Malta	MT
Belgium	BE	Netherlands	NL
Cyprus	CY	Poland	PL
Czech Republic	CR	Portugal	PT
Denmark	DK	Slovakia	SK

COUNTRY	ISO 3166 2 LETTER CODE	COUNTRY	ISO 3166 2 LETTER CODE
Estonia	EE	Slovenia	SI
Finland	FI	Spain	ES
France	FR	Sweden	SE
Germany	DE	United Kingdom	GB
Greece	GR	Iceland	IS
Hungary	HU	Liechtenstein	LI
Ireland	IE	Norway	NO
Italy	IT	Switzerland	CH
Latvia	LV	Bulgaria	BG
Lithuania	LT	Romania	RO
Luxembourg	LU	Turkey	TR

Safety Warnings

- Do NOT use this product near water, for example, in a wet basement or near a swimming pool.
- Do NOT expose your device to dampness, dust or corrosive liquids.
- Do NOT store things on the device.
- Do NOT install, use, or service this device during a thunderstorm. There is a remote risk of electric shock from lightning.
- Connect ONLY suitable accessories to the device.
- Do NOT open the device or unit. Opening or removing covers can expose you to dangerous high voltage points or other risks. ONLY qualified service personnel should service or disassemble this device. Please contact your vendor for further information.
- Make sure to connect the cables to the correct ports.
- Place connecting cables carefully so that no one will step on them or stumble over them.
- Always disconnect all cables from this device before servicing or disassembling.
- Use ONLY an appropriate power adaptor or cord for your device. Connect it to the right supply voltage (for example, 110V AC in North America or 230V AC in Europe).
- Do NOT remove the plug and connect it to a power outlet by itself; always attach the plug to the power adaptor first before connecting it to a power outlet.
- Do NOT allow anything to rest on the power adaptor or cord and do NOT place the product where anyone can walk on the power adaptor or cord.
- Do NOT use the device if the power adaptor or cord is damaged as it might cause electrocution.
- If the power adaptor or cord is damaged, remove it from the device and the power source.
- Do NOT attempt to repair the power adaptor or cord. Contact your local vendor to order a new one.
- Do not use the device outside, and make sure all the connections are indoors. There is a remote risk of electric shock from lightning.
- CAUTION: RISK OF EXPLOSION IF BATTERY (on the motherboard) IS REPLACED BY AN INCORRECT TYPE. DISPOSE OF USED BATTERIES ACCORDING TO THE INSTRUCTIONS. Dispose them at the applicable collection point for the recycling of electrical and electronic equipment. For detailed information about recycling of this product, please contact your local city office, your household waste disposal service or the store where you purchased the product.
- Do NOT obstruct the device ventilation slots, as insufficient airflow may harm your device.
- Antenna Warning! This device meets ETSI and FCC certification requirements when using the included antenna(s). Only use the included antenna(s).
- If you wall mount your wall-mountable device, make sure that no electrical lines, gas or water pipes will be damaged.

The following warnings apply if product is disconnect device:

- A readily accessible disconnect device shall be incorporated external to the equipment; and/or
- The socket-outlet shall be installed near the equipment and shall be easily accessible.

Environment Statement

ErP (Energy-related Products)

All ZyXEL products put on the EU market in compliance with the requirement of the European Parliament and the Council published Directive 2009/125/EC establishing a framework for the setting of ecodesign requirements for energy-related products (recast), so called as "ErP Directive (Energy-related Products directive)" as well as ecodesign requirement laid down in applicable implementing measures, power consumption has satisfied regulation requirements which are:

- Network standby power consumption < 12W and/or
- Off mode power consumption < 0.5W and/or
- Standby mode power consumption < 0.5W.

Please refer to "Wireless" chapter for more details on Wireless settings.

WEEE Directive

Your product is marked with this symbol, which is known as the WEEE mark. WEEE stands for Waste Electronics and Electrical Equipment. It means that used electrical and electronic products should not be mixed with general waste. Used electrical and electronic equipment should be treated separately.

Die folgende Symbol bedeutet, dass Ihr Produkt und/oder seine Batterie gemäß den örtlichen Bestimmungen getrennt vom Hausmüll entsorgt werden muss. Wenden Sie sich an eine Recyclingstation, wenn dieses Produkt das Ende seiner Lebensdauer erreicht hat. Zum Zeitpunkt der Entsorgung wird die getrennte Sammlung von Produkt und/oder seiner Batterie dazu beitragen, natürliche Ressourcen zu sparen und die Umwelt und die menschliche Gesundheit zu schützen.

El símbolo de abajo indica que según las regulaciones locales, su producto y/o su batería deberán depositarse como basura separada de la doméstica. Cuando este producto alcance el final de su vida útil, llévalo a un punto limpio. Cuando llegue el momento de desechar el producto, la recogida por separado éste y/o su batería ayudará a salvar los recursos naturales y a proteger la salud humana y medioambiental.

Le symbole ci-dessous signifie que selon les réglementations en vigueur votre produit et/ou sa batterie doivent être éliminés séparément des ordures ménagères. Lorsque ce produit atteint sa fin de vie, amenez-le à un centre de recyclage pour qu'il soit mis au rebut. La collecte séparée de votre produit et/ou de sa batterie permettra une meilleure protection de l'environnement et de la santé humaine.

Questo simbolo significa che secondo i regolamenti locali il prodotto e/o la sua batteria devono essere trattati separatamente dai rifiuti domestici. Quando questo prodotto raggiunge la fine della vita di servizio portatelo ad una stazione di riciclaggio. Questo trattamento separato del prodotto e/o della sua batteria aiuta a risparmiare risorse naturali e a proteggere l'ambiente.

Symbolen innebär att enligt lokal lagstiftning ska produkten och/eller dess batteri kastas separat från hushållsavfallet. När den här produkten når slutet av sin livslängd ska du ta den till en återvinningsstation. Separat insamling av din produkt och / eller dess batteri hjälper till att både spara naturresurser och se till att miljön når en hållbar utveckling.



Environmental Product Declaration

Bulgarski (Bulgarian)	Čeština (Czech)	Dansk (Danish)	Deutsch (German)
<p>Средствата за опазване на околната среда</p> <p>RoHS RoHS RoHS RoHS RoHS</p> <p>RoHS RoHS RoHS RoHS RoHS</p> <p>RoHS RoHS RoHS RoHS RoHS</p> <p>RoHS RoHS RoHS RoHS RoHS</p>	<p>Environmentální prohlášení o produktu</p> <p>RoHS RoHS RoHS RoHS RoHS</p> <p>RoHS RoHS RoHS RoHS RoHS</p> <p>RoHS RoHS RoHS RoHS RoHS</p> <p>RoHS RoHS RoHS RoHS RoHS</p>	<p>Miljødeklaration</p> <p>RoHS RoHS RoHS RoHS RoHS</p> <p>RoHS RoHS RoHS RoHS RoHS</p> <p>RoHS RoHS RoHS RoHS RoHS</p> <p>RoHS RoHS RoHS RoHS RoHS</p>	<p>Produkt-Umweltdeklaration</p> <p>RoHS RoHS RoHS RoHS RoHS</p> <p>RoHS RoHS RoHS RoHS RoHS</p> <p>RoHS RoHS RoHS RoHS RoHS</p> <p>RoHS RoHS RoHS RoHS RoHS</p>
Esti keel (Estonian)	English	Español (Spanish)	Français (French)
<p>Teave keskkonnakaitse kohta</p> <p>RoHS RoHS RoHS RoHS RoHS</p> <p>RoHS RoHS RoHS RoHS RoHS</p> <p>RoHS RoHS RoHS RoHS RoHS</p> <p>RoHS RoHS RoHS RoHS RoHS</p>	<p>Environmental product declaration</p> <p>RoHS RoHS RoHS RoHS RoHS</p> <p>RoHS RoHS RoHS RoHS RoHS</p> <p>RoHS RoHS RoHS RoHS RoHS</p> <p>RoHS RoHS RoHS RoHS RoHS</p>	<p>Declaración Ambiental de Producto</p> <p>RoHS RoHS RoHS RoHS RoHS</p> <p>RoHS RoHS RoHS RoHS RoHS</p> <p>RoHS RoHS RoHS RoHS RoHS</p> <p>RoHS RoHS RoHS RoHS RoHS</p>	<p>Produit environnemental de produit</p> <p>RoHS RoHS RoHS RoHS RoHS</p> <p>RoHS RoHS RoHS RoHS RoHS</p> <p>RoHS RoHS RoHS RoHS RoHS</p> <p>RoHS RoHS RoHS RoHS RoHS</p>
Hrvatski (Croatian)	Italiana (Italian)	Latviski valoda (Latvian)	Lietuvai kalba (Lithuanian)
<p>Zaštita okolišne sredine</p> <p>RoHS RoHS RoHS RoHS RoHS</p> <p>RoHS RoHS RoHS RoHS RoHS</p> <p>RoHS RoHS RoHS RoHS RoHS</p> <p>RoHS RoHS RoHS RoHS RoHS</p>	<p>Dichiarazione ambientale di prodotto</p> <p>RoHS RoHS RoHS RoHS RoHS</p> <p>RoHS RoHS RoHS RoHS RoHS</p> <p>RoHS RoHS RoHS RoHS RoHS</p> <p>RoHS RoHS RoHS RoHS RoHS</p>	<p>Produkta vides informācija deklarācija</p> <p>RoHS RoHS RoHS RoHS RoHS</p> <p>RoHS RoHS RoHS RoHS RoHS</p> <p>RoHS RoHS RoHS RoHS RoHS</p> <p>RoHS RoHS RoHS RoHS RoHS</p>	<p>Aplinkosaugimo gamtos informacija</p> <p>RoHS RoHS RoHS RoHS RoHS</p> <p>RoHS RoHS RoHS RoHS RoHS</p> <p>RoHS RoHS RoHS RoHS RoHS</p> <p>RoHS RoHS RoHS RoHS RoHS</p>
Magyar (Hungarian)	Malta (Maltese)	Nederlands (Dutch)	Polski (Polish)
<p>Környezetvédelem környékhatározás</p> <p>RoHS RoHS RoHS RoHS RoHS</p> <p>RoHS RoHS RoHS RoHS RoHS</p> <p>RoHS RoHS RoHS RoHS RoHS</p> <p>RoHS RoHS RoHS RoHS RoHS</p>	<p>Dejgħażenji Ambjentali dwar il-Prodott</p> <p>RoHS RoHS RoHS RoHS RoHS</p> <p>RoHS RoHS RoHS RoHS RoHS</p> <p>RoHS RoHS RoHS RoHS RoHS</p> <p>RoHS RoHS RoHS RoHS RoHS</p>	<p>Miljøproduktdeklarering</p> <p>RoHS RoHS RoHS RoHS RoHS</p> <p>RoHS RoHS RoHS RoHS RoHS</p> <p>RoHS RoHS RoHS RoHS RoHS</p> <p>RoHS RoHS RoHS RoHS RoHS</p>	<p>Załącznik środowiskowy produktu</p> <p>RoHS RoHS RoHS RoHS RoHS</p> <p>RoHS RoHS RoHS RoHS RoHS</p> <p>RoHS RoHS RoHS RoHS RoHS</p> <p>RoHS RoHS RoHS RoHS RoHS</p>
Português (Portuguese)	Română (Romanian)	Slovenčina (Slovak)	Slovenščina (Slovene)
<p>Declaração ambiental do produto</p> <p>RoHS RoHS RoHS RoHS RoHS</p> <p>RoHS RoHS RoHS RoHS RoHS</p> <p>RoHS RoHS RoHS RoHS RoHS</p> <p>RoHS RoHS RoHS RoHS RoHS</p>	<p>Declarație de mediu privind produsul</p> <p>RoHS RoHS RoHS RoHS RoHS</p> <p>RoHS RoHS RoHS RoHS RoHS</p> <p>RoHS RoHS RoHS RoHS RoHS</p> <p>RoHS RoHS RoHS RoHS RoHS</p>	<p>Výhlásenie o prostredníctvom správy</p> <p>RoHS RoHS RoHS RoHS RoHS</p> <p>RoHS RoHS RoHS RoHS RoHS</p> <p>RoHS RoHS RoHS RoHS RoHS</p> <p>RoHS RoHS RoHS RoHS RoHS</p>	<p>Okolišna deklaracija izdelka</p> <p>RoHS RoHS RoHS RoHS RoHS</p> <p>RoHS RoHS RoHS RoHS RoHS</p> <p>RoHS RoHS RoHS RoHS RoHS</p> <p>RoHS RoHS RoHS RoHS RoHS</p>
Suomi (Finnish)	Svenska (Swedish)	Ελληνικά (Greek)	Norsk (Norwegian)
<p>Ympäristöympäristö ympäristödeklaration</p> <p>RoHS RoHS RoHS RoHS RoHS</p> <p>RoHS RoHS RoHS RoHS RoHS</p> <p>RoHS RoHS RoHS RoHS RoHS</p> <p>RoHS RoHS RoHS RoHS RoHS</p>	<p>Miljødeklaration</p> <p>RoHS RoHS RoHS RoHS RoHS</p> <p>RoHS RoHS RoHS RoHS RoHS</p> <p>RoHS RoHS RoHS RoHS RoHS</p> <p>RoHS RoHS RoHS RoHS RoHS</p>	<p>Περιβαλλοντική Δήλωση Προϊόντος</p> <p>RoHS RoHS RoHS RoHS RoHS</p> <p>RoHS RoHS RoHS RoHS RoHS</p> <p>RoHS RoHS RoHS RoHS RoHS</p> <p>RoHS RoHS RoHS RoHS RoHS</p>	<p>Miljødeklarasjon</p> <p>RoHS RoHS RoHS RoHS RoHS</p> <p>RoHS RoHS RoHS RoHS RoHS</p> <p>RoHS RoHS RoHS RoHS RoHS</p> <p>RoHS RoHS RoHS RoHS RoHS</p>

Viewing Certifications

Go to <http://www.zyxel.com> to view this product's documentation and certifications.

ZyXEL Limited Warranty

ZyXEL warrants to the original end user (purchaser) that this product is free from any defects in material or workmanship for a specific period (the Warranty Period) from the date of purchase. The Warranty Period varies by region. Check with your vendor and/or the authorized ZyXEL local distributor for details about the Warranty Period of this product. During the warranty period, and upon proof of purchase, should the product have indications of failure due to faulty workmanship and/or materials, ZyXEL will, at its discretion, repair or replace the defective products or components without charge for either parts or labor, and to whatever extent it shall deem necessary to restore the product or components to proper operating condition. Any replacement will consist of a new or re-manufactured functionally equivalent product of equal or higher value, and will be solely at the discretion of ZyXEL. This warranty shall not apply if the product has been modified, misused, tampered with, damaged by an act of God, or subjected to abnormal working conditions.

Note

Repair or replacement, as provided under this warranty, is the exclusive remedy of the purchaser. This warranty is in lieu of all other warranties, express or implied, including any implied warranty of merchantability or fitness for a particular use or purpose. ZyXEL shall in no event be held liable for indirect or consequential damages of any kind to the purchaser.

To obtain the services of this warranty, contact your vendor. You may also refer to the warranty policy for the region in which you bought the device at http://www.zyxel.com/web/support_warranty_info.php.

Registration

Register your product online to receive e-mail notices of firmware upgrades and information at www.zyxel.com for global products, or at www.us.zyxel.com for North American products.

Open Source Licenses

This product contains in part some free software distributed under GPL license terms and/or GPL like licenses. Open source licenses are provided with the firmware package. You can download the latest firmware at www.zyxel.com. If you cannot find it there, contact your vendor or ZyXEL Technical Support at support@zyxel.com.tw.

To obtain the source code covered under those Licenses, please contact your vendor or ZyXEL Technical Support at support@zyxel.com.

Numbers

10/100/1000 Mbps [4](#)

A

Applications [6](#)
 Segment Bridge [6](#)
auto-negotiating ports [9](#)

C

Cabling Length [19](#)
certifications
 notices [21](#)
 viewing [28](#)
copyright [20](#)

D

Data path loop [19](#)
disclaimer [20](#)

E

EEE [4, 9](#)
Energy Efficient Ethernet [9](#)

F

Faulty cables [19](#)
FCC interference statement [20, 24](#)
Front Panel [9](#)

Front Panel Connections [11](#)

H

High Power over Ethernet [7](#)

I

IEEE 802.3at [7](#)
IEEE 802.3az [9](#)
installation
 precautions [15](#)
 transceivers [10](#)

L

LED Descriptions
 LK/ACT [13](#)
 PWR [12, 13](#)
Low Power Idle [9](#)
LPI signal [9](#)

M

mounting brackets [15](#)

N

network cable
 crossover [11](#)
 straight-through [11](#)
Network Cable Types [11](#)
Non-standard network cables [19](#)

P

- PD [7](#)
- PoE [7](#)
 - power supplying [7](#)
- Power over Ethernet [7](#)
- power saving [9](#)
- powered device [7](#)
- product registration [28](#)

R

- rack mounting [15](#)
- Rear Panel [8](#)
- Rear Panel Power Connection [8](#)
- registration
 - product [28](#)

S

- Small Form-factor Pluggable (SFP) [9](#)
- Standalone Workgroup [6](#)

T

- transceiver MultiSource Agreement (MSA) [9](#)
- transceivers [9](#)
 - installation [10](#)
 - removal [10](#)
- Troubleshooting
 - Improper Network Cabling and Topology [19](#)

W

- wall mounting [14](#)
- warranty [28](#)
 - note [28](#)