

EMC Test Report

Equipment under Test : FLAME GUN
Model /Type : 915
Listed Models : 920, 621, 622, 623, 625, 627

Applicant : **Wenzhou Qunmu Light Industry Manufacturing Co., Ltd**
Address : Dongshou, 2nd Floor, Building 1, South Side Of Xiannan Industrial Zone, Ouhai District, Wenzhou City, Zhejiang Province
Manufacturer : **Wenzhou Qunmu Light Industry Manufacturing Co., Ltd**
Address : Dongshou, 2nd Floor, Building 1, South Side Of Xiannan Industrial Zone, Ouhai District, Wenzhou City, Zhejiang Province

Laboratory : Shenzhen Youbest Testing Technology Co., Ltd.
Address : 204, Building B, Chuneng Science Park, No. 111, Huanguan Middle Road, Songyuanxia Community, Guanhu Street, Longhua District, Shenzhen, Guangdong, P.R. China
Website : [http:// www.youbest-lab.com](http://www.youbest-lab.com)

Test Result:	PASS
---------------------	-------------

TEST RESULT CERTIFICATION

Applicant's name **Wenzhou Qunmu Light Industry Manufacturing Co., Ltd**
Address Dongshou, 2nd Floor, Building 1, South Side Of Xiannan Industrial
Zone, Ouhai District, Wenzhou City, Zhejiang Province
Manufacturer's Name.... **Wenzhou Qunmu Light Industry Manufacturing Co., Ltd**
Address Dongshou, 2nd Floor, Building 1, South Side Of Xiannan Industrial
Zone, Ouhai District, Wenzhou City, Zhejiang Province

Product description

Product name FLAME GUN
Model No. 915, 920, 621, 622, 623, 625, 627

Standards **EN 55014-1:2017+A11:2020**
EN IEC 61000-3-2:2019,
EN 61000-3-3:2013+A1:2019
EN 55014-2:2021

This device described above has been tested by YouBest, and the test results show that the equipment under test (EUT) is in compliance with the 2014/30/EU requirements. And it is applicable only to the tested sample identified in the report.

This report shall not be reproduced except in full, without the written approval of YouBest, this document may be altered or revised by YouBest, personal only, and shall be noted in the revision of the document.

Date of Test.....:

Date (s) of performance of tests: March 7, 2022 to March 9, 2022

Date of Issue: March 10, 2022

Test Result: **Pass**

Compiled by:

Reviewed by:

Approved by:

Daisy Li

Snow Wu

Jasse Liu/Manager

This test report is based on a single evaluation of one sample of above mentioned products. It is not permitted to be duplicated in extracts without written approval of Shenzhen Youbest Testing Technology Co., Ltd.

Table of Contents	Page
1 . TEST SUMMARY	5
1.1 TEST FACILITY	6
1.2 MEASUREMENT UNCERTAINTY	6
2 . GENERAL INFORMATION	7
2.1 GENERAL DESCRIPTION OF EUT	7
2.2 <i>DESCRIPTION OF TEST MODES</i>	8
2.3 <i>DESCRIPTION OF TEST SETUP</i>	9
2.4 DESCRIPTION TEST PERIPHERAL AND EUT PERIPHERAL	9
2.5 MEASUREMENT INSTRUMENTS LIST	10
3 . EMC EMISSION TEST	13
3.1 CONDUCTED EMISSION MEASUREMENT	13
3.1.1 POWER LINE CONDUCTED EMISSION	13
3.1.3 TEST PROCEDURE	14
3.1.4 TEST SETUP	14
3.1.5 EUT OPERATING CONDITIONS	14
3.1.6 TEST RESULTS	15
3.2 RADIATED EMISSION MEASUREMENT	16
3.2.1 LIMITS OF RADIATED EMISSION MEASUREMENT	16
3.2.2 LIMITS OF DISTURBANCE POWER MEASUREMENT	16
3.2.3 TEST PROCEDURE	16
3.2.4 TEST SETUP	17
3.2.5 EUT OPERATING CONDITIONS	17
3.2.6 TEST RESULTS(30MHz-1000MHz)	18
3.2.7 TEST RESULTS(30MHz ~300MHz)	20
3.3 HARMONICS CURRENT	21
3.3.1 LIMITS OF HARMONICS CURRENT	21
3.3.1.1 TEST PROCEDURE	22
3.3.1.2 EUT OPERATING CONDITIONS	22
3.3.1.3 TEST SETUP	22
3.3.2 TEST RESULTS	23
3.4 VOLTAGE FLUCTUATION AND FLICKERS	24
3.4.1 LIMITS OF VOLTAGE FLUCTUATION AND FLICKERS	24
3.4.1.1 TEST PROCEDURE	24
3.4.1.2 EUT OPERATING CONDITIONS	24
3.4.1.3 TEST SETUP	24
3.4.2 TEST RESULTS	25
4 . EMC IMMUNITY TEST	26
4.1 STANDARD COMPLIANCE/ SERVIRTY LEVEL/ CRITERIA	26

Table of Contents	Page
4.2 GENERAL PERFORMANCE CRITERIA	27
4.3 GENERAL PERFORMANCE CRITERIA TEST SETUP	27
4.4 ESD TESTING	28
4.4.1 TEST SPECIFICATION	28
4.4.2 TEST PROCEDURE	28
4.4.3 TEST SETUP	29
4.4.4 TEST RESULTS	30
4.5 RS TESTING	31
4.5.1 TEST SPECIFICATION	31
4.5.2 TEST PROCEDURE	31
4.5.3 TEST SETUP	32
4.5.4 TEST RESULTS	33
4.6 EFT/BURST TESTING	34
4.6.1 TEST SPECIFICATION	34
4.6.2 TEST PROCEDURE	34
4.6.3 TEST SETUP	35
4.6.4 TEST RESULTS	35
4.7 SURGE TESTING	37
4.7.1 TEST SPECIFICATION	37
4.7.2 TEST PROCEDURE	37
4.7.3 TEST SETUP	38
4.7.4 TEST RESULTS	39
4.8 INJECTION CURRENT TESTING	40
4.8.1 TEST SPECIFICATION	40
4.8.2 TEST PROCEDURE	40
4.8.3 TEST SETUP	40
4.8.4 TEST RESULTS	40
4.9 VOLTAGE INTERRUPTION/DIPS TESTING	42
4.9.1 TEST SPECIFICATION	42
4.9.2 TEST PROCEDURE	42
4.9.3 TEST SETUP	42
4.9.4 TEST RESULTS	43
5. EUT PHOTOGRAPHS	44

1. TEST SUMMARY

Test procedures according to the technical standards:

EMC Emission				
Standard	Test Item	Limit	Judgment	Remark
EN 55014-1:2017+A11:2020	Conducted Emission	Class B	N/A	
	Radiated Emission	Class B	PASS	
EN61000-3-2: 2019	Harmonic Current Emission	Class A or D NOTE (2)	N/A	
EN 61000-3-3:2013+A1:2019	Voltage Fluctuations & Flicker	-----	N/A	
EMC Immunity				
Section EN 55014-2: 2021	Test Item	Performance Criteria	Judgment	Remark
EN 61000-4-2: 2009	Electrostatic Discharge	B	PASS	
EN 61000-4-3:2006+A1:2008+A2: 2010	RF electromagnetic field	A	PASS	
EN 61000-4-4: 2012	Fast transients	B	N/A	
EN 61000-4-5: 2006	Surges	B	N/A	
EN 61000-4-6: 2012	Injected Current	A	N/A	
EN 61000-4-11: 2004	Volt. Interruptions Volt. Dips	C / C / C NOTE (3)	N/A	

NOTE:

- (1)' N/A' denotes test is not applicable in this Test Report
 - (2) No limits apply for equipment with an active input power up to and including 75W.
 - (3) Voltage dip: 0% reduction – Performance Criteria **C**
 Voltage dip: 30% reduction – Performance Criteria **C**
 Voltage dip: 60% reduction – Performance Criteria **C**
- For client's request and manual description, the test will not be executed.

1.1 TEST FACILITY

Shenzhen Youbest Testing Technology Co., Ltd.
204, Building B, Chuneng Science Park, No. 111, Huanguan Middle Road, Songyuanxia
Community, Guanhu Street, Longhua District, Shenzhen, Guangdong, P.R. China

1.2 MEASUREMENT UNCERTAINTY

The reported uncertainty of measurement $y \pm U$, where expanded uncertainty U is based on a standard uncertainty multiplied by a coverage factor of $k=2$, providing a level of confidence of approximately **95** %.

Test Item	Uncertainty
Conducted Emission	2.6dB
Radiated Emission(Below 1G)	4.56dB(distance:3m; Polarize:V)
	4.42dB(distance:3m; Polarize:H)
Radiated Emission(1GHz-18GHz)	3.78dB(distance:3m; Polarize:V)
	3.69dB(distance:3m; Polarize:H)
Flicker test	1.7%
Harmonic test	1.88dB
R/S Test	0.92dB
C/S Test	0.68 dB
Test Site Temperature And Humidity	0.6°C
	3%

2. GENERAL INFORMATION

2.1 GENERAL DESCRIPTION OF EUT

Equipment	FLAME GUN				
Model Name	915				
Brand	QUNMU				
Additional Model Number(s)	920, 621, 622, 623, 625, 627				
Model Difference	Only model name and appearance are different				
Product Description	The EUT is a FLAME GUN.				
	<table border="1"><tr><td>Operating frequency:</td><td>N/A</td></tr><tr><td>Connecting I/O port:</td><td>N/A</td></tr></table>	Operating frequency:	N/A	Connecting I/O port:	N/A
	Operating frequency:	N/A			
Connecting I/O port:	N/A				
Based on the application, features, or specification exhibited in User's Manual, the EUT is considered as a Household Device. More details of EUT technical specification, please refer to the User's Manual.					
Power Source	N/A				
Power Rating	N/A				

2.2 DESCRIPTION OF TEST MODES

To investigate the maximum EMI emission characteristics generated from EUT, the test system was pre-scanning tested based on the consideration of following EUT operation mode or test configuration mode which possibly have effect on EMI emission level. Each of these EUT operation mode(s) or test configuration mode(s) mentioned above was evaluated respectively.

Pretest Mode	Description
Mode 1	Running

For Conducted Test	
Final Test Mode	Description
Mode 1	Running

For Radiated Test	
Final Test Mode	Description
Mode 1	Running

For EMS Test	
Final Test Mode	Description
Mode 1	Running

2.3 DESCRIPTION OF TEST SETUP

Mode 1:

E-1
EUT

2.4 DESCRIPTION TEST PERIPHERAL AND EUT PERIPHERAL

The EUT has been tested as an independent unit together with other necessary accessories or support units. The following support units or accessories were used to form a representative test configuration during the tests.

Item	Equipment	Mfr/Brand	Model/Type No.	Series No.	Note
E-1	FLAME GUN	N/A	915	N/A	EUT

Item	Shielded Type	Ferrite Core	Length	Note

Note:

- (1) The support equipment was authorized by Declaration of Confirmation.
- (2) For detachable type I/O cable should be specified the length in cm in 『Length』 column.
- (3) 'YES' means 'shielded' 'with core'; 'NO' means 'unshielded' 'without core'.

2.5 MEASUREMENT INSTRUMENTS LIST

2.5.1 CONDUCTED EMISSION

Item	Kind of Equipment	Manufacturer	Type No.	Serial No.	Last calibration	Calibrated until	Calibration period
1	LISN	R&S	ENV216	101334	Apr. 2,2021	Apr. 1,2022	1 year
2	LISN	SCHWARZBECK	NNLK 8129	8129267	Apr. 2,2021	Apr. 1,2022	1 year
3	Pulse Limiter	SCHWARZBECK	VTSD 9561F	9716	Apr. 2,2021	Apr. 1,2022	1 year
4	50Ω Switch	ANRITSU CORP	MP59B	6200983704	Apr. 2,2021	Apr. 1,2022	1 year
5	Test Cable	N/A	C01	N/A	Apr. 2,2021	Apr. 1,2022	1 year
6	Test Cable	N/A	C02	N/A	Apr. 2,2021	Apr. 1,2022	1 year
7	Test Cable	N/A	C03	N/A	Apr. 2,2021	Apr. 1,2022	1 year
8	EMI Test Receiver	R&S	ESCI	101318	Apr. 2,2021	Apr. 1,2022	1 year
9	Passive Voltage Probe	ESH2-Z3	R&S	100173	Apr. 2,2021	Apr. 1,2022	1 year
10	Triple-Loop Antenna	EVERFINE	LIA-2	11020016	Apr. 2,2021	Apr. 1,2022	1 year
11	Absorbing Clamp	R&S	MDS-21	100423	Apr. 2,2021	Apr. 1,2022	1 year

2.5.2 RADIATED TEST SITE

Item	Kind of Equipment	Manufacturer	Type No.	Serial No.	Last calibration	Calibrated until	Calibration period
1	Bilog Antenna	TESEQ	CBL6111D	31437	Apr. 2,2021	Apr. 1,2022	1 year
2	Test Cable	N/A	R-01	N/A	Apr. 2,2021	Apr. 1,2022	1 year
3	Test Cable	N/A	R-02	N/A	Apr. 2,2021	Apr. 1,2022	1 year
4	EMI Test Receiver	Rohde&Schwarz	ESVD	847312/008	Apr. 2,2021	Apr. 1,2022	1 year
5	Antenna Mast	EM	SC100_1	N/A	N/A	N/A	N/A
6	Turn Table	EM	SC100	060533	N/A	N/A	N/A
7	50Ω Switch	Anritsu Corp	MP59B	6200983705	Apr. 2,2021	Apr. 1,2022	1 year
8	Spectrum Analyzer	Aglient	E4407B	160400005	Apr. 2,2021	Apr. 1,2022	1 year
9	Horn Antenna	EM	EM-AH-10180	2011071402	Apr. 2,2021	Apr. 1,2022	1 year
10	Amplifier	EM	EM-30180	060536	Apr. 2,2021	Apr. 1,2022	1 year

2.5.3 HARMONICS AND FILCK

Item	Kind of Equipment	Manufacturer	Type No.	Serial No.	Last calibration	Calibrated until	Calibration period
1	Harmonic & Flicker	EM TEST	DPA500	0303-08	Apr. 2,2021	Apr. 1,2022	1 year
2	AC Power Source	EM TEST	ACS500	0203-06	Apr. 2,2021	Apr. 1,2022	1 year

2.5.4 ESD

Item	Kind of Equipment	Manufacturer	Type No.	Serial No.	Last calibration	Calibrated until	Calibration period
1	ESD TEST GENERATOR	SCHAFFNER	NSG438	858	Apr. 2,2021	Apr. 1,2022	1 year

2.5.5 RS

Item	Kind of Equipment	Manufacturer	Type No.	Serial No.	Last calibration	Calibrated until	Calibration period
1	Signal Generator	R&S	SMT 06	832080/007	Apr. 2,2021	Apr. 1,2022	1 year
2	Log-Bicon Antenna	Schwarzbeck	VULB9161	4022	Apr. 2,2021	Apr. 1,2022	1 year
3	Power Amplifier	AR	150W1000M1	320946	Apr. 2,2021	Apr. 1,2022	1 year
4	Microwave Horn Antenna	AR	AT4002A	321467	Apr. 2,2021	Apr. 1,2022	1 year
5	Power Amplifier	AR	25S1G4A	308598	Apr. 2,2021	Apr. 1,2022	1 year

2.5.6 SURGE, EFT/BURST, VOLTAGE INTERRUPTION/DIPS

Item	Kind of Equipment	Manufacturer	Type No.	Serial No.	Last calibration	Calibrated until	Calibration period
1	Surge Generator	EVERFINE	EMS61000-5A	1101002	Apr. 2,2021	Apr. 1,2022	1 year
2	DIPS Generator	EVERFINE	EMS61000-11K	1011002	Apr. 2,2021	Apr. 1,2022	1 year
3	EFT/B Generator	EVERFINE	EMS61000-4A-V2	1012005	Apr. 2,2021	Apr. 1,2022	1 year

2.5.7 INJECTION CURRENT

Item	Kind of Equipment	Manufacturer	Type No.	Serial No.	Last calibration	Calibrated until	Calibration period
1	Signal Generator	IFR	2023A	202301/368	Apr. 2,2021	Apr. 1,2022	1 year
2	Power Amplifier	AR	75A250AM1	0320709	Apr. 2,2021	Apr. 1,2022	1 year
3	CDN	FCC	FCC-801-M2	06043	Apr. 2,2021	Apr. 1,2022	1 year
4	EM Clamp	FCC	F-203I-23MM	504	Apr. 2,2021	Apr. 1,2022	1 year

2.4.8 MF

Item	Kind of Equipment	Manufacturer	Type No.	Serial No.	Last calibration	Calibrated until	Calibration period
1	Generator	EVERFINE	EMS61000-8K	1007001	Apr. 2,2021	Apr. 1,2022	1 year

DRAFT

3. EMC EMISSION TEST

3.1 CONDUCTED EMISSION MEASUREMENT

3.1.1 POWER LINE CONDUCTED EMISSION (Frequency Range 150KHz-30MHz)

Frequency Range (MHz)	At mains terminals		At load terminals and additional terminals	
	Quasi-peak (dBuV)	Average (dBuV)	Quasi-peak (dBuV)	Average (dBuV)
0.15 -0.5	66 - 56 *	56 - 46 *	80.00	70.00
0.50 -5.0	56.00	46.00	74.00	64.00
5.0 -30.0	60.00	50.00	74.00	64.00

3.1.2 MAINS TERMINALS OF TOOLS

Frequency Range (MHz)	Rated motor power not exceeding 700W		Rated motor power above 700W and not exceeding 1 000 W		Rated motor power above 1 000 W	
	dB (uV) Quasi-peak	dB (uV) Average**	dB (uV) Quasi-peak	dB (uV) Average**	dB (uV) Quasi-peak	dB (uV) Average**
0.15 -0.5	66.0 to 59.0*	59.0 to 49.0*	70.0 to 63.0*	63.0 to 53.0*	76.0 to 69.0*	69.0 to 59.0*
0.50 -5.0	59.0	49.0	63.0	53.0	69.0	59.0
5.0 -30.0	64.0	54.0	68.0	58.0	74.0	64.0

Note:

- (1) The tighter limit applies at the band edges.
- (2) The limit of ' * ' marked band means the limitation decreases linearly with the logarithm of the frequency in the range.
- (3) '**' If the limit for the measurement with the average detector is met when using a receiver with a quasi-peak detector, the equipment under test shall be deemed to meet both limits and the measurement using the receiver with an average detector need not be carried out.

The following table is the setting of the receiver

Receiver Parameters	Setting
Attenuation	10 dB
Start Frequency	0.15 MHz
Stop Frequency	30 MHz
IF Bandwidth	9 kHz

3.1.3 TEST PROCEDURE

- a. The EUT was placed 0.8 meters from the horizontal ground plane with EUT being connected to the power mains through a line impedance stabilization network (LISN). All other support equipments powered from additional LISN(s). The LISN provide 50 Ohm/ 50uH of coupling impedance for the measuring instrument.
- b. Interconnecting cables that hang closer than 40 cm to the ground plane shall be folded back and forth in the center forming a bundle 30 to 40 cm long.
- c. I/O cables that are not connected to a peripheral shall be bundled in the center. The end of the cable may be terminated, if required, using the correct terminating impedance. The overall length shall not exceed 1 m.
- d. LISN at least 80 cm from nearest part of EUT chassis.
- e. For the actual test configuration, please refer to the related Item –EUT Test Photos.

3.1.4 TEST SETUP

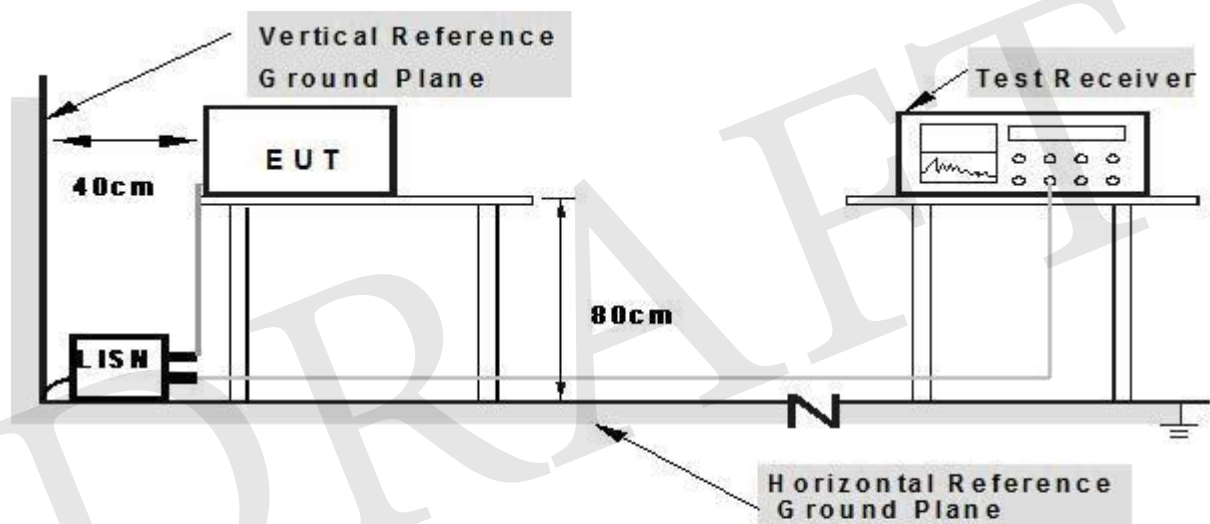

Note: 1. Support units were connected to second LISN.

2. Both of LISNs (AMN) are 80 cm from EUT and at least 80 cm from other units and other metal planes

3.1.5 EUT OPERATING CONDITIONS

The EUT tested system was configured as the statements of 2.3 Unless otherwise a special operating condition is specified in the follows during the testing.

3.1.6 TEST RESULTS

EUT :	FLAME GUN	Model Name. :	915
Temperature :	25 °C	Relative Humidity :	58%
Pressure :	1025hPa	Test Date :	N/A
Test Mode :	N/A	Phase :	N/A
Test Voltage :	N/A		

DRAFT

3.2 RADIATED EMISSION MEASUREMENT

3.2.1 LIMITS OF RADIATED EMISSION MEASUREMENT (Below 1000MHz)

FREQUENCY (MHz)	At 10m	At 3m
	dBuV/m	dBuV/m
30 – 230	30	40
230 – 1000	37	47

3.2.2 LIMITS OF DISTURBANCE POWER MEASUREMENT (Below 1000MHz)

Frequency Range	Household and similar appliances		Tools					
	dB (pW) Quasi-peak	dB (pW) Averag*	Rated motor power not exceeding 700 W		Rated motor power above 700 W and not exceeding 1 000 W		Rated motor power above 1 000 W	
(MHz)			dB (pW) Quasi-peak	dB (pW) Averag*	dB (pW) Quasi-peak	dB (pW) Averag*	dB (pW) Quasi-peak	dB (pW) Average*
30-300	44-55	35-45	44-55	35-45	49-59	39-49	55-65	45-55

* If the limit for the measurement with the average detector is met when using a receiver with a quasi-peak detector, the equipment under test shall be deemed to meet both limits and the measurement using the receiver with an average detector need not be carried out.

Notes:

- (1) The limit for radiated test was performed according to as following: CISPR 14.
- (2) The tighter limit applies at the band edges.
- (3) Emission level (dBuV/m)=20log Emission level (uV/m).

3.2.3 TEST PROCEDURE

- a. The measuring distance of at 10 m shall be used for measurements at frequency up to 1GHz. For frequencies above 1GHz, any suitable measuring distance may be used.
- b. The EUT was placed on the top of a rotating table 0.8 meters above the ground at a 10 meter open area test site. The table was rotated 360 degrees to determine the position of the highest radiation.
- c. The height of the equipment or of the substitution antenna shall be 0.8 m; the height of the test antenna shall vary between 1 m to 4 m. Both horizontal and vertical polarizations of the antenna are set to make the measurement.
- d. The initial step in collecting conducted emission data is a spectrum analyzer peak detector mode pre-scanning the measurement frequency range. Significant peaks are then marked and then Quasi Peak detector mode re-measured, above 1G Average detector mode will be instead.

- e. If the Peak Mode measured value compliance with and lower than Quasi Peak Mode Limit, the EUT shall be deemed to meet QP(AV) Limits and then no additional QP Mode measurement performed.
- f. For the actual test configuration, please refer to the related Item –EUT Test Photos.

3.2.4 TEST SETUP

(A) Radiated Emission Test Set-Up Frequency Below 1 GHz.

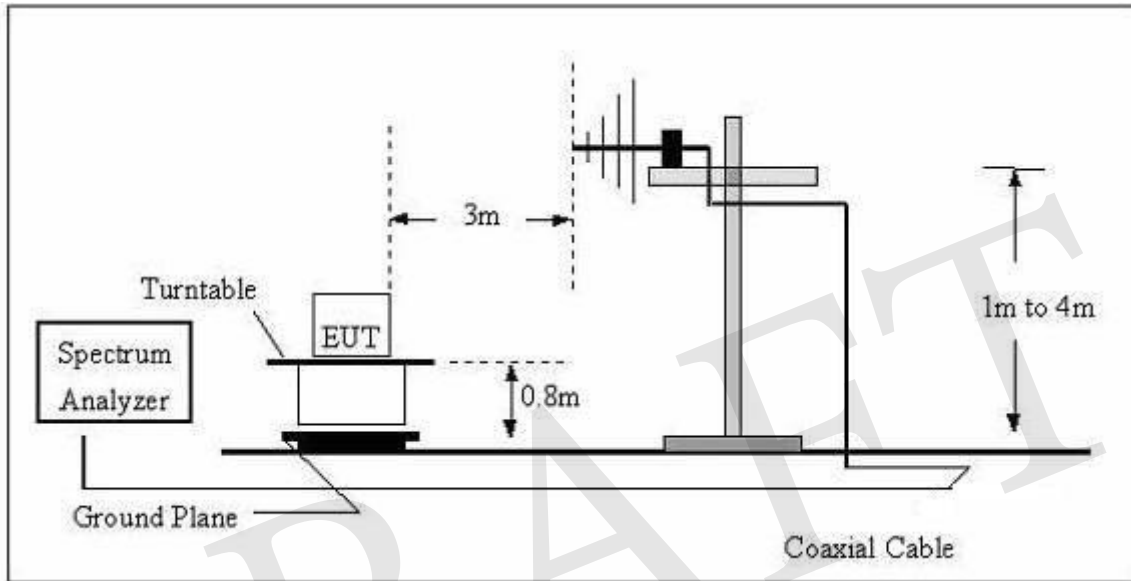

(B) Disturbance Power Test Set-UP Frequency Below 1GHz

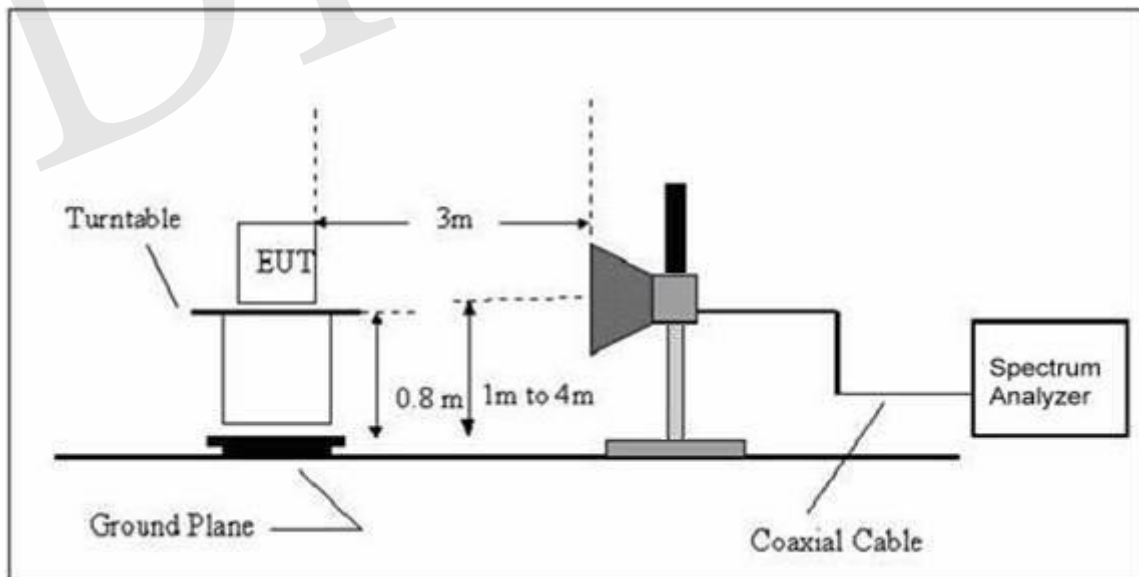

3.2.5 EUT OPERATING CONDITIONS

The EUT tested system was configured as the statements of 2.3 Unless otherwise a special operating condition is specified in the follows during the testing.

3.2.6 TEST RESULTS(30MHz-1000MHz)

EUT :	FLAME GUN	Model Name. :	915
Temperature :	25 °C	Relative Humidity :	58%
Pressure :	1025hPa	Test Date :	2022-03-09
Test Mode :	Running	Phase :	Horizontal
Test Voltage :	N/A		

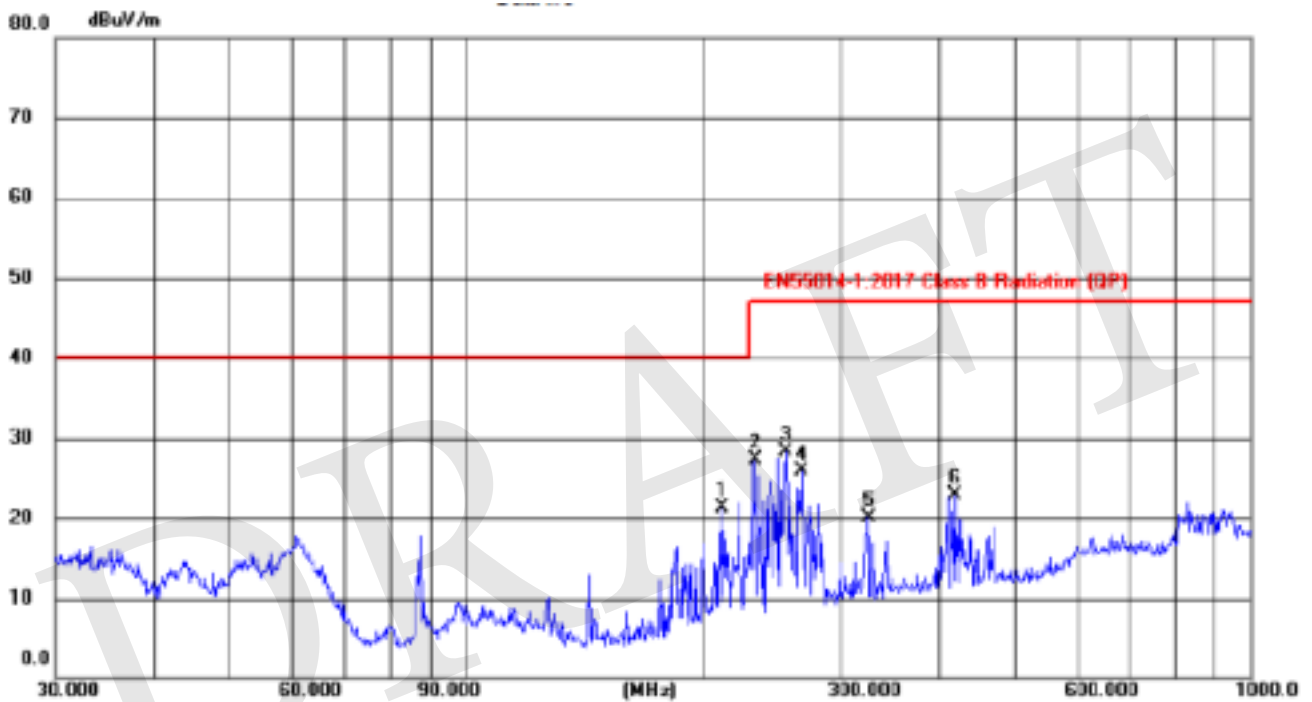

No.	Mk.	Freq. MHz	Reading Level dBuV	Correct Factor dB	Measure- ment dBuV/m	Limit dBuV/m	Over dB	Detector	Comment
1		211.5265	42.90	-21.58	21.32	40.00	18.68	peak	
2		233.3487	48.51	-21.22	27.29	47.00	19.71	peak	
3	*	255.6231	49.12	-20.76	28.36	47.00	18.64	peak	
4		267.5455	46.34	-20.41	25.93	47.00	21.07	peak	
5		324.4561	39.34	-19.21	20.13	47.00	26.87	peak	
6		419.1081	40.65	-17.83	22.82	47.00	24.18	peak	

EUT :	FLAME GUN	Model Name. :	915
Temperature :	25 °C	Relative Humidity :	58%
Pressure :	1025hPa	Test Date :	2022-03-09
Test Mode :	Running	Phase :	Vertical
Test Voltage :	N/A		

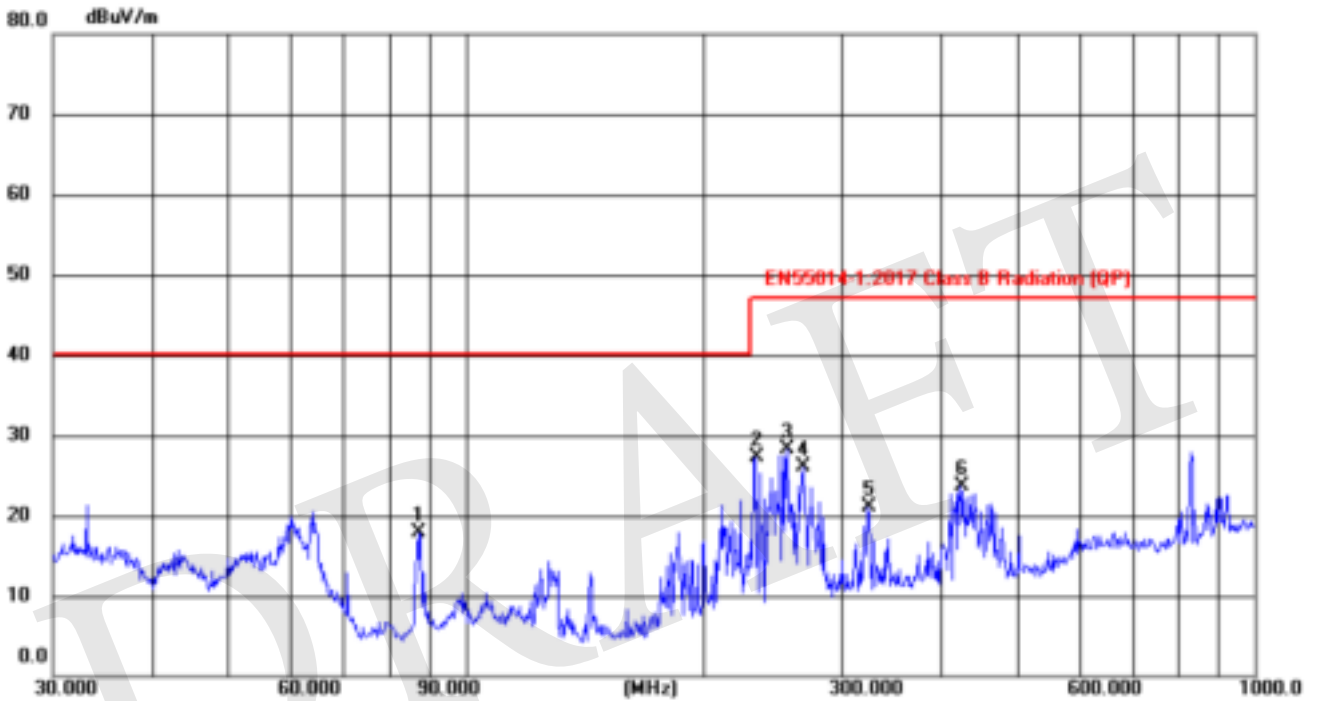

No.	Mk.	Freq.	Reading Level	Correct Factor	Measurement	Limit	Over	Detector	Comment
		MHz	dBuV	dB	dBuV/m	dBuV/m	dB		
1		87.1117	42.04	-24.13	17.91	40.00	22.09	peak	
2		233.3487	48.51	-21.22	27.29	47.00	19.71	peak	
3	*	255.6231	49.12	-20.76	28.36	47.00	18.64	peak	
4		267.5455	46.59	-20.41	26.18	47.00	20.82	peak	
5		323.3204	40.31	-19.23	21.08	47.00	25.92	peak	
6		423.5403	41.54	-17.82	23.72	47.00	23.28	peak	

3.2.7 TEST RESULTS(30MHz ~300MHz)

EUT :	FLAME GUN	Model Name. :	915
Temperature :	25 °C	Relative Humidity :	58%
Pressure :	1025hPa	Test Date :	N/A
Test Mode :	N/A	Phase :	N/A
Test Voltage :	N/A		

DRAFT

3.3.1.1 TEST PROCEDURE

- a. The EUT was placed on the top of a wooden table 0.8 meters above the ground and operated to produce the maximum harmonic components under normal operating conditions.
- b. The classification of EUT is according to section 5 of EN 61000-3-2. The EUT is classified as follows:
Class A: Balanced three-phase equipment, Household appliances excluding equipment as Class D, Tools excluding portable tools, Dimmers for incandescent lamps, audio equipment, equipment not specified in one of the three other classes.
Class B: Portable tools. Portable tools.; Arc welding equipment which is not professional equipment.
Class C: Lighting equipment.
Class D: Equipment having a specified power less than or equal to 600W of the following types: Personal computers and personal computer monitors and television receivers.
- c. The correspondent test program of test instrument to measure the current harmonics emanated from EUT is chosen. The measure time shall be not less than the time necessary for the EUT to be exercised.

3.3.1.2 EUT OPERATING CONDITIONS

The EUT tested system was configured as the statements of **2.3** Unless otherwise a special operating condition is specified in the follows during the testing.

3.3.1.3 TEST SETUP

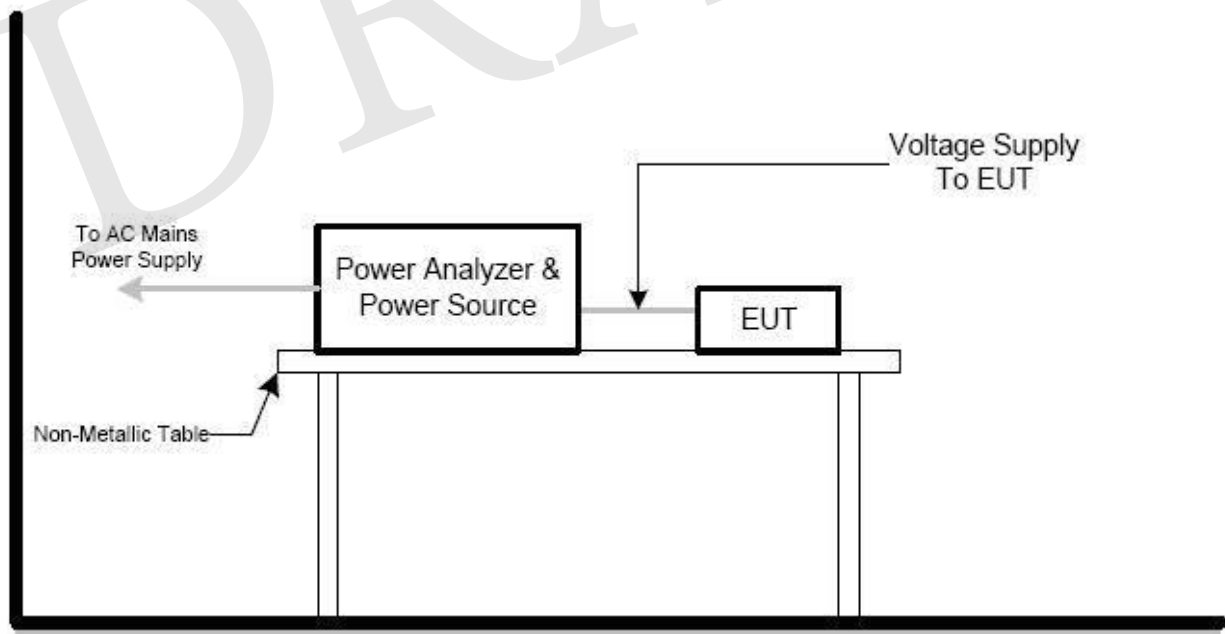

3.3.2 TEST RESULTS

EUT :	FLAME GUN	Model Name :	915
Temperature :	25 °C	Relative Humidity :	58%
Pressure :	1025 hPa	Test Date :	N/A
Test Mode :	N/A		
Test Power :	N/A		

DRAFT

3.4.2 TEST RESULTS

EUT :	FLAME GUN	Model Name :	915
Temperature :	25 °C	Relative Humidity :	58%
Pressure :	N/A	Test Date :	N/A
Test Mode :	N/A		
Test Power :	N/A		

DRAFT

4. EMC IMMUNITY TEST

4.1 STANDARD COMPLIANCE/ SERVITY LEVEL/ CRITERIA

Tests Standard No.	TEST SPECIFICATION	Test Mode Test Ports	Perform. Criteria
1. ESD IEC/EN 61000-4-2	8KV air discharge 4KV contact discharge	Direct Mode	B
	4KV HCP discharge 4KV VCP discharge	Indirect Mode	B
2. RS IEC/EN 61000-4-3	80 MHz to 1000 MHz, 1000Hz, 80%, AM modulated	Enclosure	A
3. EFT/Burst IEC/EN 61000-4-4	5/50ns Tr/Th 5KHz Repetition Freq.	Power Supply Port	B
	5/50ns Tr/Th 5KHz Repetition Freq.	CTL/Signal Data Line Port	B
4. Surges IEC/EN 61000-4-5	1.2/50(8/20) Tr/Th us	L-N	B
	1.2/50(8/20) Tr/Th us	L-PE N-PE	B
5 Injected Current IEC/EN 61000-4-6	0.15 MHz to 80 MHz, 1000Hz 80 % , AM Modulated 150Ω source impedance	CTL/Signal Port	A
	0.15 MHz to 80 MHz, 1000Hz 80 % , AM Modulated 150Ω source impedance	AC Power Port	A
	0.15 MHz to 80 MHz, 1000Hz 80 % , AM Modulated 150Ω source impedance	DC Power Port	A
6. Power Frequency Magnetic Field IEC/EN 61000-4-8	50 Hz,	Enclosure	A
7. Volt. Interruptions Volt. Dips IEC/EN 61000-4-11	Voltage dip 0%	AC Power Port	C
	Voltage dip 30%		C
	Voltage dip 60%		C

4.2 GENERAL PERFORMANCE CRITERIA

According to **EN 55014-2** standard, the general performance criteria as following:

Criterion A	<p>The equipment shall continue to operate as intended without operator intervention. No degradation of performance or loss of function is allowed below a performance level specified by the manufacturer when the equipment is used as intended.</p> <p>The performance level may be replaced by a permissible loss of performance. If the minimum performance level or the permissible performance loss is not specified by the manufacturer, then either of these may be derived from the product description and documentation, and by what the user may reasonably expect from the equipment if used as intended.</p>
Criterion B	<p>After the test, the equipment shall continue to operate as intended without operator intervention. No degradation of performance or loss of function is allowed, after the application of the phenomena below a performance level specified by the manufacturer, when the equipment is used as intended.</p> <p>The performance level may be replaced by a permissible loss of performance. During the test, degradation of performance is allowed. However, no change of operating state or stored data is allowed to persist after the test.</p>
Criterion C	<p>Loss of function is allowed, provided the function is self-recoverable, or can be restored by the operation of the controls by the user in accordance with the manufacturer's instructions.</p> <p>Functions, and/or information stored in non-volatile memory, or protected by a battery backup, shall not be lost.</p>

4.3 GENERAL PERFORMANCE CRITERIA TEST SETUP

The EUT tested system was configured as the statements of **2.3** Unless otherwise a special operating condition is specified in the follows during the testing.

4.4 ESD TESTING

4.4.1 TEST SPECIFICATION

Basic Standard:	IEC/EN 61000-4-2
Discharge Impedance:	330 ohm / 150 pF
Required Performance	B
Discharge Voltage:	Air Discharge : 2kV/4kV/8kV (Direct) Contact Discharge : 2kV/4kV (Direct/Indirect)
Polarity:	Positive & Negative
Number of Discharge:	Air Discharge: min. 20 times at each test point Contact Discharge: min. 20 at each test point
Discharge Mode:	Single Discharge
Discharge Period:	1 second minimum

4.4.2 TEST PROCEDURE

The test generator necessary to perform direct and indirect application of discharges to the EUT in the following manner:

- a. Contact discharge was applied to conductive surfaces and coupling planes of the EUT. During the test, it was performed with single discharges. For the single discharge time between successive single discharges was at least 1 second. The EUT shall be exposed to at least 200 discharges, 100 each at negative and positive polarity, at a minimum of four test points. One of the test points shall be subjected to at least 50 indirect discharges to the center of the front edge of the horizontal coupling plane. The remaining three test points shall each receive at least 50 direct contact discharges.

If no direct contact test points are available, then at least 200 indirect discharges shall be applied in the indirect mode. Test shall be performed at a maximum repetition rate of one discharge per second.

Vertical Coupling Plane (VCP):

The coupling plane, of dimensions 0.5m x 0.5m, is placed parallel to, and positioned at a distance 0.1m from, the EUT, with the Discharge Electrode touching the coupling plane.

The four faces of the EUT will be performed with electrostatic discharge.

Horizontal Coupling Plane (HCP):

The coupling plane is placed under to the EUT. The generator shall be positioned vertically at a distance of 0.1m from the EUT, with the Discharge Electrode touching the coupling plane.

The four faces of the EUT will be performed with electrostatic discharge.

- b. Air discharges at insulation surfaces of the EUT.

It was at least ten single discharges with positive and negative at the same selected point.

4.4.3 TEST SETUP

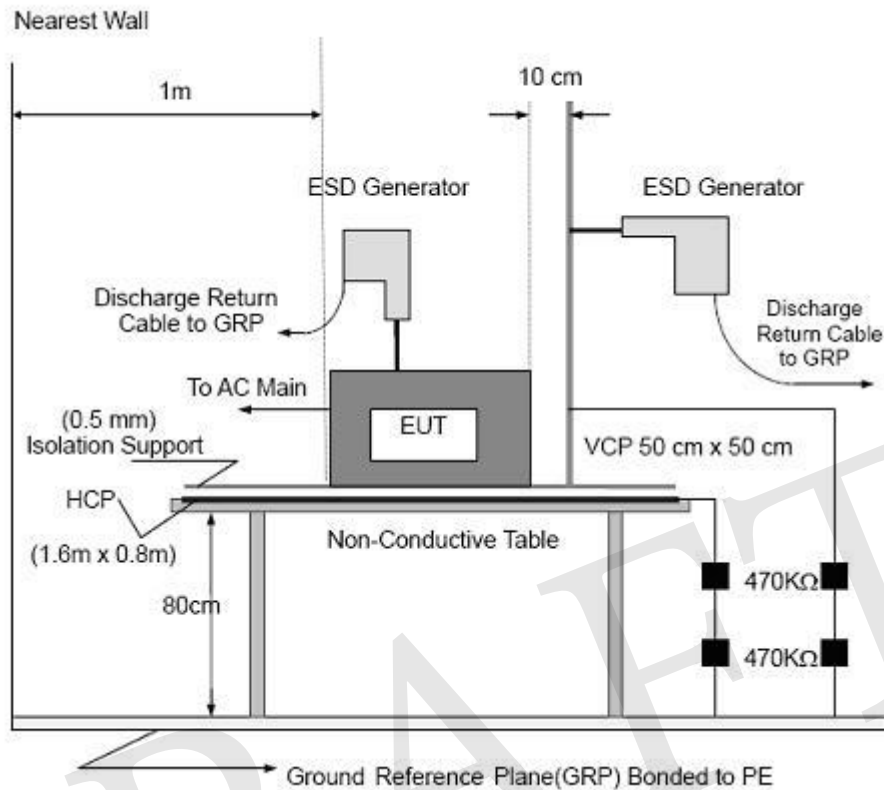

Note:

TABLE-TOP EQUIPMENT

The configuration consisted of a wooden table 0.8 meters high standing on the Ground Reference Plane. The GRP consisted of a sheet of aluminum at least 0.25mm thick, and 2.5 meters square connected to the protective grounding system. A Horizontal Coupling Plane (1.6m x 0.8m) was placed on the table and attached to the GRP by means of a cable with 940k total impedance. The equipment under test, was installed in a representative system as described in section 7 of IEC /EN 61000-4-2, and its cables were placed on the HCP and isolated by an insulating support of 0.5mm thickness. A distance of 1-meter minimum was provided between the EUT and the walls of the laboratory and any other metallic structure.

FLOOR-STANDING EQUIPMENT

The equipment under test was installed in a representative system as described in section 7 of IEC/EN 61000-4-2, and its cables were isolated from the Ground Reference Plane by an insulating support of 0.1-meter thickness. The GRP consisted of a sheet of aluminum that is at least 0.25mm thick, and 2.5meters square connected to the protective grounding system and extended at least 0.5 meters from the EUT on all sides.

4.4.4 TEST RESULTS

EUT :	FLAME GUN	Model Name :	915
Temperature :	25 °C	Relative Humidity :	58%
Pressure :	1025hPa	Test Date :	2022-03-09
Test Mode :	Running		
Test Power :	N/A		

Mode	Air Discharge								Contact Discharge								Criterion	Result
	2		4		8		15		2		4		6		8			
Test level (kV)																		
Test Location	+	-	+	-	+	-	+	-	+	-	+	-	+	-	+	-		
HCP									A	A	A	A					B	PASS
VCP									A	A	A	A						PASS
shell									A	A	A	A						PASS

Note:

- 1) +/- denotes the Positive/Negative polarity of the output voltage.
- 2) Test condition:
Direct / Indirect (HCP/VCP) discharges: Minimum 50 times (Positive/Negative) at each point. Air discharges: Minimum 10 times (Positive/Negative) at each point.
- 3) Test location(s) in which discharge (Air and contact discharge) to be applied illustrated by photos shown in next page(s)
- 4) The Indirect (HCP/VCP) discharges description of test point as following:
1. left side 2.right side 3.front side 4.rear side.
- 5) N/A - denotes test is not applicable in this test report.

4.5 RS TESTING

4.5.1 TEST SPECIFICATION

Basic Standard:	IEC/EN 61000-4-3
Required Performance	A
Frequency Range:	80 MHz - 1000 MHz
Field Strength:	3 V/m
Modulation:	1kHz Sine Wave, 80%, AM Modulation
Frequency Step:	1 % of fundamental
Polarity of Antenna:	Horizontal and Vertical
Test Distance:	3 m
Antenna Height:	1.5 m
Dwell Time:	at least 3 seconds

4.5.2 TEST PROCEDURE

The EUT and support equipment, which are placed on a table that is 0.8 meter above ground and the testing was performed in a fully-anechoic chamber.

The testing distance from antenna to the EUT was 3 meters.

The other condition as following manner:

- a. The frequency range is swept from 80 MHz to 1000 MHz, & 1400MHz - 2700MHz with the signal 80%amplitude modulated with a 1kHz sine wave. The rate of sweep did not exceed 1.5x 10⁻³ decade/s. Where the frequency range is swept incrementally, the step size was 1% of fundamental.
- b. Sweep Frequency 900 MHz, with the Duty Cycle: 1/8 and Modulation: Pulse 217 Hz(if applicable)
- c. The dwell time at each frequency shall be not less than the time necessary for the EUT to be able to respond.
- d. The test was performed with the EUT exposed to both vertically and horizontally polarized fields on each of the four sides.

4.5.3 TEST SETUP

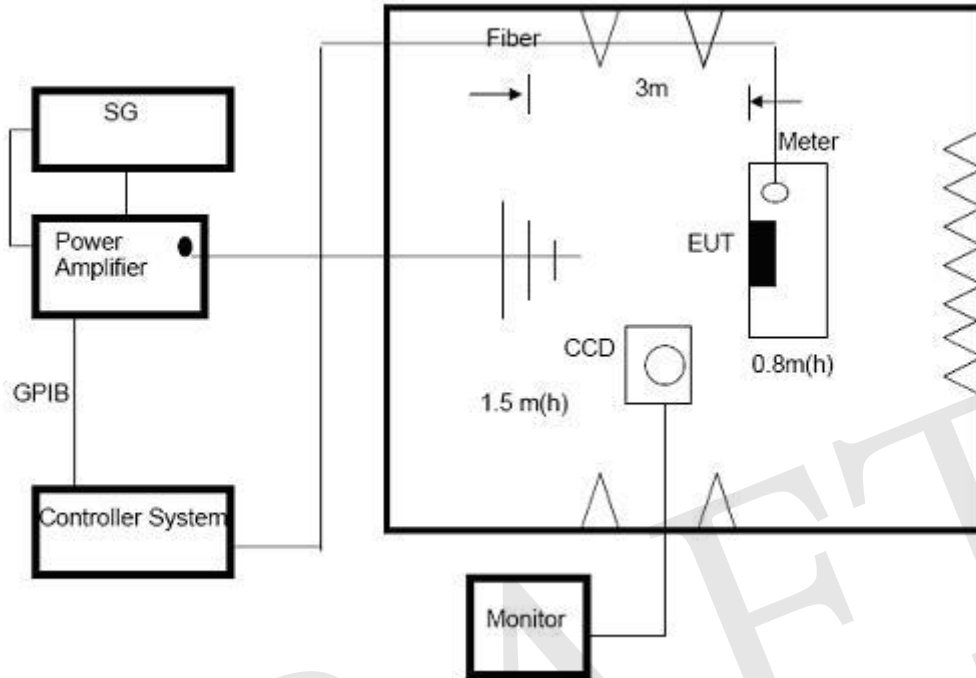

Note:

TABLE-TOP EQUIPMENT

The EUT installed in a representative system as described in section 7 of IEC/EN 61000-4-3 was placed on a non-conductive table 0.8 meters in height. The system under test was connected to the power and signal wire according to relevant installation instructions.

FLOOR-STANDING EQUIPMENT

The EUT installed in a representative system as described in section 7 of IEC/EN 61000-4-3 was placed on a non-conductive wood support 0.1 meters in height. The system under test was connected to the power and signal wire according to relevant installation instructions.

4.5.4 TEST RESULTS

EUT :	FLAME GUN	Model Name :	915
Temperature :	25 °C	Relative Humidity :	60%
Pressure :	1025hPa	Test Date :	2022-03-09
Test Mode :	Running		
Test Power :	N/A		

Frequency Range (MHz)	RF Field Position	R.F. Field Strength	Azimuth	Perform. Criteria	Results	Judgment
80MHz - 1000MHz	H / V	3 V/m (rms) AM Modulated 1000Hz, 80%	Front	A	A	PASS
			Rear			
			Left			
			Right			

Note:

- 1) N/A - denotes test is not applicable in this test report.
- 2) Criteria A: There was no change operated with initial operating during the test.
- 3) Criteria B: The EUT function loss during the test, but self-recoverable after the test.
- 4) Criteria C: The system shut down during the test.

4.6 EFT/BURST TESTING

4.6.1 TEST SPECIFICATION

Basic Standard:	IEC/EN 61000-4-4
Required Performance	B
Test Voltage:	Power Line : 1 kV Signal/Control Line : 0.5 KV
Polarity:	Positive & Negative
Impulse Frequency:	5 kHz
Impulse Wave shape :	5/50 ns
Burst Duration:	15 ms
Burst Period:	300 ms
Test Duration:	Not less than 1 min.

4.6.2 TEST PROCEDURE

The EUT and its simulators were placed on a ground reference plane and were insulated from it by a wood support 0.1m + 0.01m thick. The ground reference plane was 1m*1m metallic sheet with 0.65mm minimum thickness. The other condition as following manner:

- a. The length of power cord between the coupling device and the EUT should not exceed 1 meter.
- b. Both positive and negative polarity discharges were applied.
- c. The duration time of each test sequential was 1 minute.

4.6.3 TEST SETUP

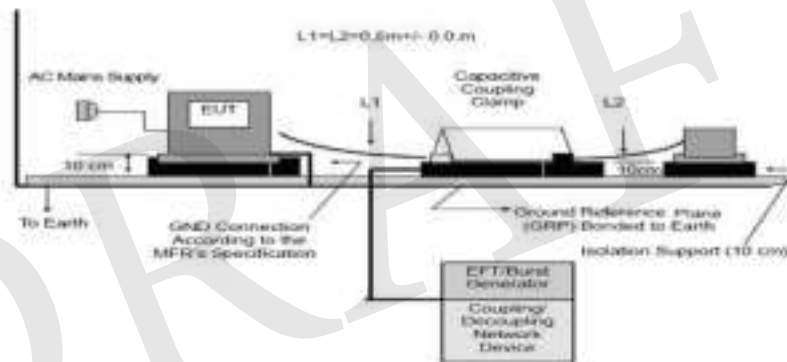
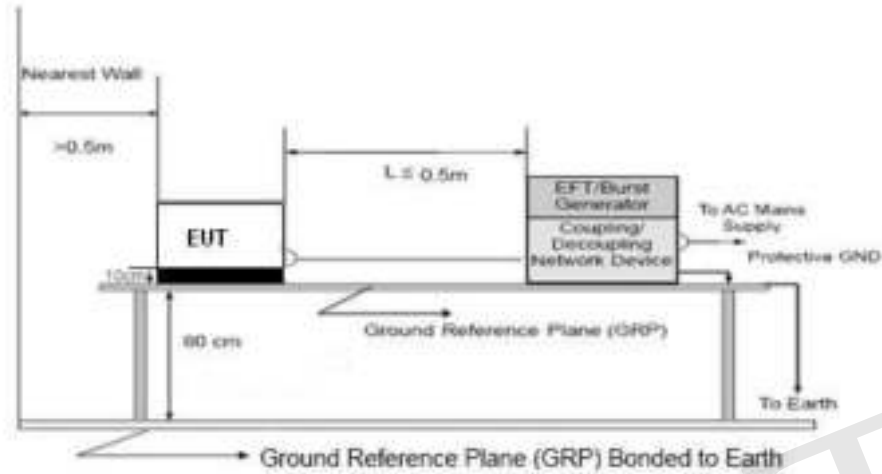

Note:

TABLE-TOP EQUIPMENT

The configuration consisted of a wooden table (0.8m high) standing on the Ground Reference Plane. The GRP consisted of a sheet of aluminum (at least 0.25mm thick and 2.5m square) connected to the protective grounding system. A minimum distance of 0.5m was provided between the EUT and the walls of the laboratory or any other metallic structure.

FLOOR-STANDING EQUIPMENT

The EUT installed in a representative system as described in section 7 of IEC/EN 61000-4-4 and its cables, were isolated from the Ground Reference Plane by an insulating support that is 0.1-meter thick. The GRP consisted of a sheet of aluminum (at least 0.25mm thick and 2.5m square) connected to the protective grounding system.

4.6.4 TEST RESULTS

EUT :	FLAME GUN	Model Name :	915
Temperature :	25 °C	Relative Humidity :	60%
Pressure :	1025 hPa	Test Date :	N/A
Test Mode :	N/A		
Test Power :	N/A		

Note:

- 1) +/- denotes the Positive/Negative polarity of the output voltage.
- 2) N/A - denotes test is not applicable in this test report.
- 3) Criteria A: There was no change operated with initial operating during the test.
- 4) Criteria B: The EUT function loss during the test, but self-recoverable after the test.
- 5) Criteria C: The system shut down during the test.

DRAFT

4.7 SURGE TESTING

4.7.1 TEST SPECIFICATION

Basic Standard:	IEC/EN 61000-4-5
Required Performance	B
Wave-Shape:	Combination Wave 1.2/50 us Open Circuit Voltage 8 /20 us Short Circuit Current
Test Voltage:	Power Line : 0.5 kV, 1 kV, 2 kV
Surge Input/Output:	L-N, L-PE, N-PE
Generator Source:	2 ohm between networks
Impedance:	12 ohm between network and ground
Polarity:	Positive/Negative
Phase Angle:	0 /90/180/270°
Pulse Repetition Rate:	1 time / min. (maximum)
Number of Tests:	5 positive and 5 negative at selected points

4.7.2 TEST PROCEDURE

a. For EUT power supply:

The surge is to be applied to the EUT power supply terminals via the capacitive coupling network. Decoupling networks are required in order to avoid possible adverse effects on equipment not under test that may be powered by the same lines, and to provide sufficient decoupling impedance to the surge wave. The power cord between the EUT and the coupling/decoupling networks shall be 2meters in length (or shorter).

b. For test applied to unshielded unsymmetrically operated interconnection lines of EUT:

The surge is applied to the lines via the capacitive coupling. The coupling /decoupling networks shall not influence the specified functional conditions of the EUT. The interconnection line between the EUT and the coupling/decoupling networks shall be 2 meters in length (or shorter).

c. For test applied to unshielded symmetrically operated interconnection /telecommunication lines of EUT:

d. The surge is applied to the lines via gas arrestors coupling. Test levels below the ignition point of the coupling arrestor cannot be specified. The interconnection line between the EUT and the coupling/decoupling networks shall be 2 meters in length (or shorter).

4.7.3 TEST SETUP

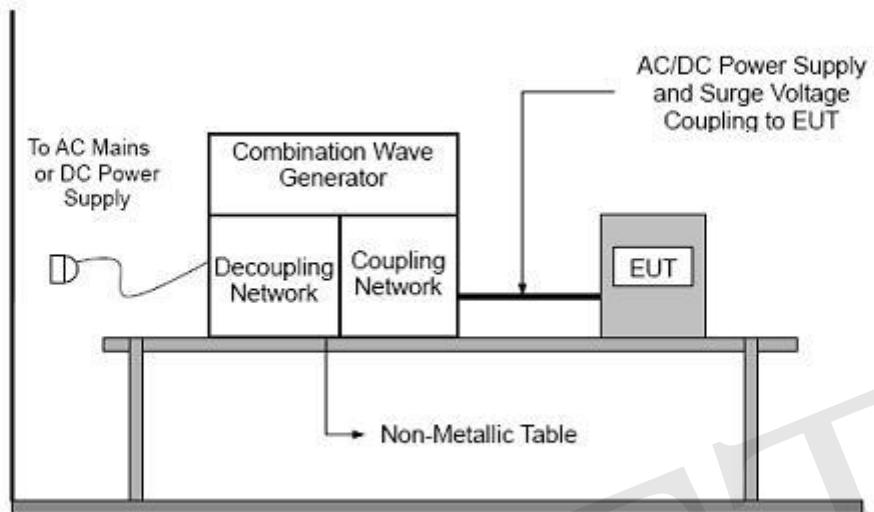

DRAFT

4.7.4 TEST RESULTS

EUT :	FLAME GUN	Model Name :	915
Temperature :	25 °C	Relative Humidity :	60%
Pressure :	1025 hPa	Test Date :	N/A
Test Mode :	N/A		
Test Power :	N/A		

Note:

- 1) Polarity and Numbers of Impulses : 5 Pst / Ngst at each tested mode.
- 2) N/A - denotes test is not applicable in this Test Report.
- 3) Criteria A: There was no change operated with initial operating during the test.
- 4) Criteria B: The EUT function loss during the test, but self-recoverable after the test.
- 5) Criteria C: The system shut down during the test.

DRAFT

EUT :	FLAME GUN	Model Name :	915
Temperature :	25 °C	Relative Humidity :	60%
Pressure :	1025 hPa	Test Date :	N/A
Test Mode :	N/A		
Test Power :	N/A		

Note:

- 1) N/A - denotes test is not applicable in this Test Report.
- 2) Criteria A: There was no change operated with initial operating during the test.
- 3) Criteria B: The EUT function loss during the test, but self-recoverable after the test.
- 4) Criteria C: The system shut down during the test.

DRAFT

4.9 VOLTAGE INTERRUPTION/DIPS TESTING

4.9.1 TEST SPECIFICATION

Basic Standard:	IEC/EN 61000-4-11
Required Performance:	C (For 0% Voltage Dips) C (For 30% Voltage Dips) C (For 60% Voltage Dips)
Test Duration Time:	Minimum three test events in sequence
Interval between Event:	Minimum ten seconds
Phase Angle:	0°/45°/90°/135°/180°/225°/270°/315°/360°
Test Cycle:	3 times

4.9.2 TEST PROCEDURE

The EUT shall be tested for each selected combination of test levels and duration with a sequence of three dips/interruptions with intervals of 10 s minimum (between each test event). Each representative mode of operation shall be tested. Abrupt changes in supply voltage shall occur at zero crossings of the voltage waveform.

4.9.3 TEST SETUP

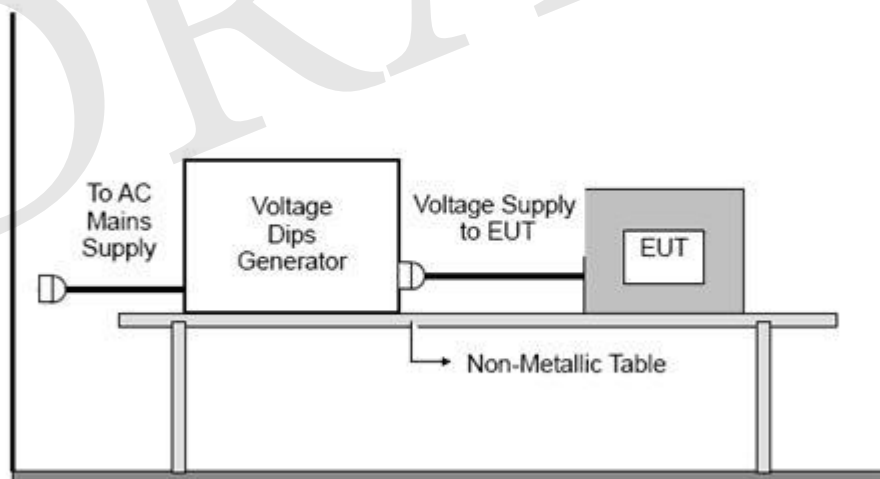

4.9.4 TEST RESULTS

EUT :	FLAME GUN	Model Name :	915
Temperature :	25 °C	Relative Humidity :	60%
Pressure :	1025 hPa	Test Date :	N/A
Test Mode :	N/A		
Test Power :	N/A		

Note:

- 1). N/A - denotes test is not applicable in this test report.
- 2) Criteria A: There was no change operated with initial operating during the test.
- 3) Criteria B: The EUT function loss during the test, but self-recoverable after the test.
- 4) Criteria C: The system shut down during the test.

DRAFT

5. EUT PHOTOGRAPHS



※※※※※END OF REPORT※※※※※