



VIDEOS & FURTHER INFORMATION



www.sigmasport.com

**INSTALLATION**

**CONTENTS**

**BC 10.0 wired**  
1 + 2 + 3

BC 10.0 WR

1 Cable mount  
Art.-Nr. 00530

2 Magnet  
Art.-Nr. 00537

3 Cable ties



**BC 10.0 wireless**  
3 + 4 + 5 + 6

BC 10.0 WL

4 Speed transmitter  
Art.-Nr. 00540

5 Mount  
Art.-Nr. 00534

6 Power Magnet  
Art.-Nr. 00538



**FIRST START**

Press 5 sec.

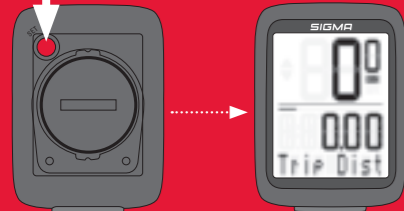

Battery already installed / Batterie bereits eingebaut / Pile déjà installée / Batteria già installata / Bateria ya instalada / Bateria já instalada / Batterij reeds geïnstalleerd / Bateria już zainstalowana / Bateria je již nainstalována

**INSTALLATION MOUNT**

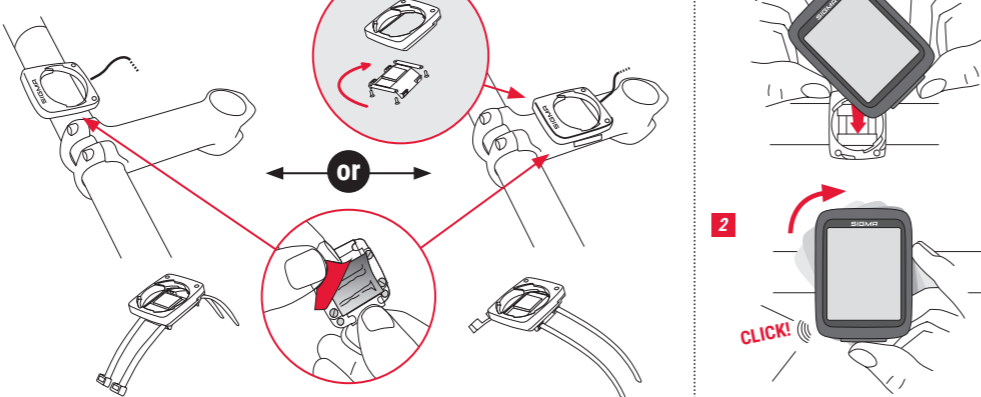

**INSTALLATION WIRED SPEED SENSOR**

**WIRED**

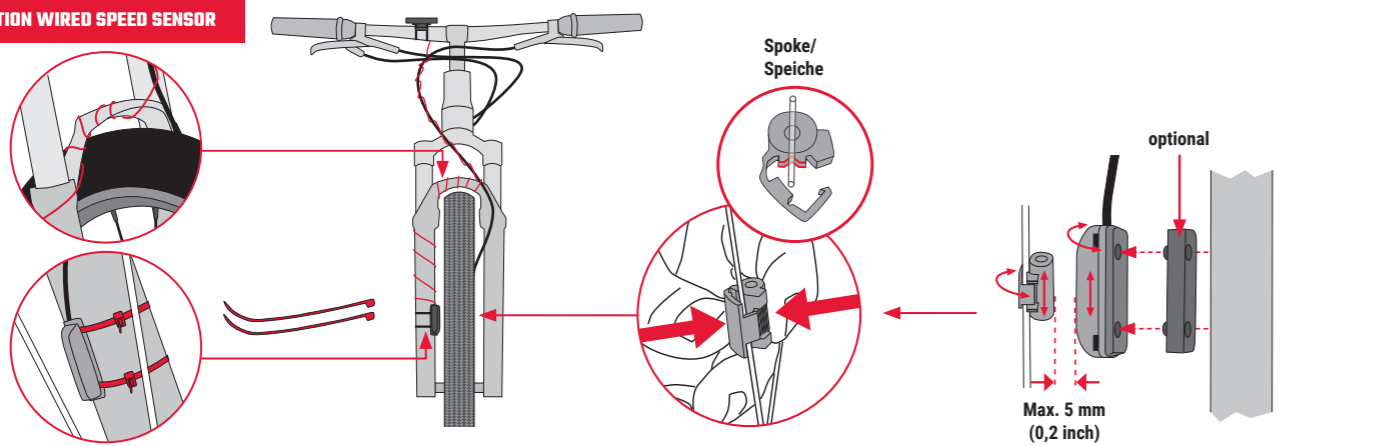

**INSTALLATION WIRELESS SPEED TRANSMITTER**

Emission frequency: 112 kHz, Max power < 11.37 dBm

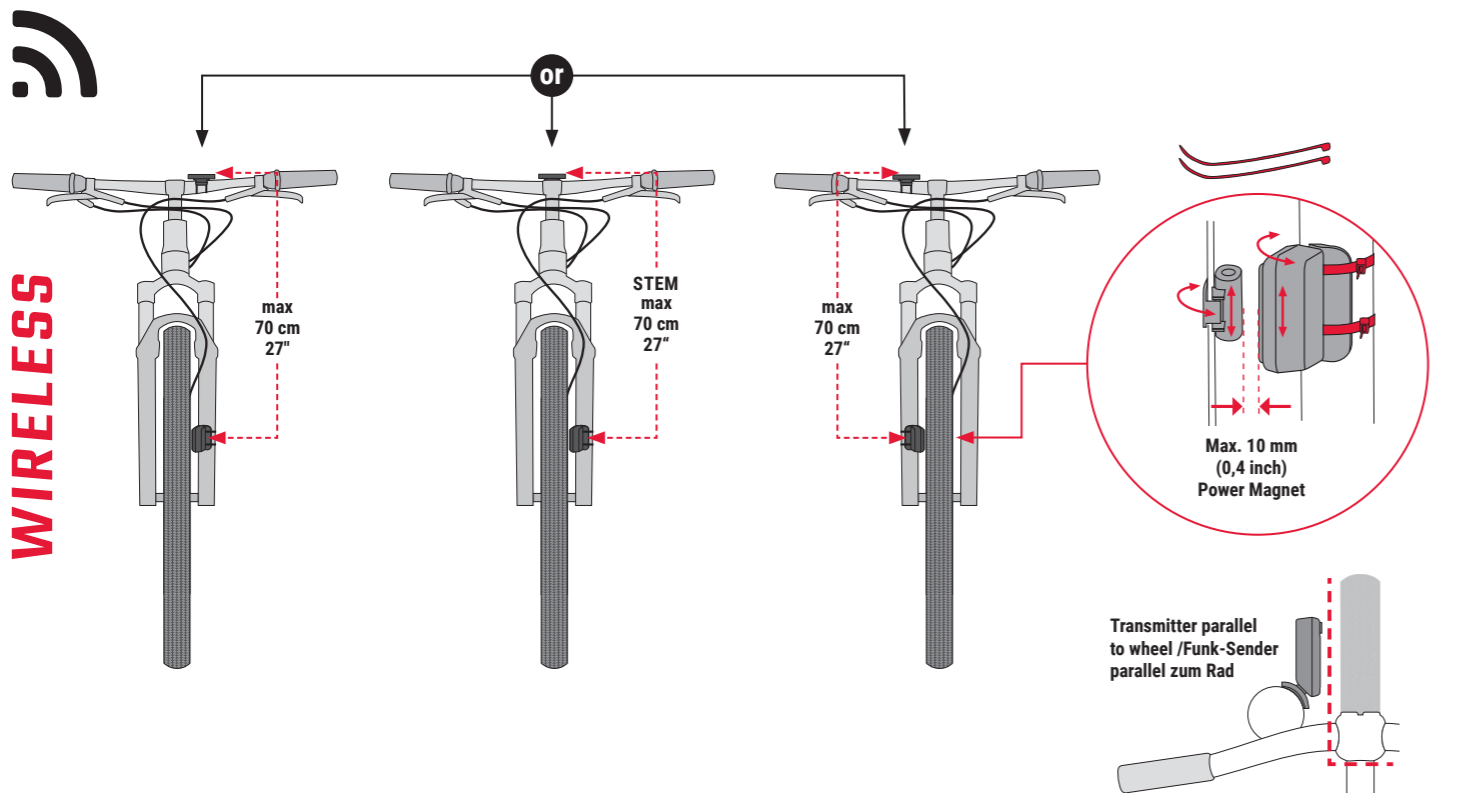

**WIRELESS**

**TECHNICAL DATA**

<p><b>EN Computer WIRED:</b></p> <ul style="list-style-type: none"> <li>- Battery type: CR 2032, 3V</li> <li>- Battery life: 3 years (When used for 1 hour per day)</li> </ul>	<p><b>Computer WIRELESS:</b></p> <ul style="list-style-type: none"> <li>- Battery type: CR 2032, 3V</li> <li>- Battery life: 2 years (When used for 1 hour per day)</li> </ul> <p><b>Transmitter:</b></p> <ul style="list-style-type: none"> <li>- Battery type: CR 2032, 3V</li> <li>- Battery life: 1.5 years (When used for 1 hour per day)</li> </ul>
<p><b>DE Computer KABELGEBUNDEN:</b></p> <ul style="list-style-type: none"> <li>- Batterietyp: CR 2032, 3V</li> <li>- Batterielebensdauer: 3 Jahre (Bei einer Benutzung von 1 Stunde pro Tag)</li> </ul>	<p><b>Computer KABELLOS:</b></p> <ul style="list-style-type: none"> <li>- Batterietyp: CR 2032, 3V</li> <li>- Batterielebensdauer: 2 Jahre (Bei einer Benutzung von 1 Stunde pro Tag)</li> </ul> <p><b>Sender:</b></p> <ul style="list-style-type: none"> <li>- Batterietyp: CR 2032, 3V</li> <li>- Batterielebensdauer: 1,5 Jahre (Bei einer Benutzung von 1 Stunde pro Tag)</li> </ul>
<p><b>FR Compteur AVEC FIL :</b></p> <ul style="list-style-type: none"> <li>- Type de pile : CR 2032, 3V</li> <li>- Autonomie : 3 ans (1 heure d'utilisation par jour)</li> </ul>	<p><b>Compteur SANS FIL :</b></p> <ul style="list-style-type: none"> <li>- Type de pile : CR 2032, 3V</li> <li>- Autonomie : 2 ans (1 heure d'utilisation par jour)</li> </ul> <p><b>Emetteur :</b></p> <ul style="list-style-type: none"> <li>- Type de pile : CR 2032, 3V</li> <li>- Autonomie : 1,5 an (1 heure d'utilisation par jour)</li> </ul>
<p><b>IT Computer DOTATO DI CAVI:</b></p> <ul style="list-style-type: none"> <li>- Tipo di batteria: CR 2032, 3V</li> <li>- Durata della batteria: da 3 anni (a fronte di un utilizzo di 1 ora al giorno)</li> </ul>	<p><b>Computer SENZA CAVI:</b></p> <ul style="list-style-type: none"> <li>- Tipo di batteria: CR 2032, 3V</li> <li>- Durata della batteria: 2 anni (a fronte di un utilizzo di 1 ora al giorno)</li> </ul> <p><b>Sensore:</b></p> <ul style="list-style-type: none"> <li>- Tipo di batteria: CR 2032, 3V</li> <li>- Durata della batteria: 1 anno e mezzo (a fronte di un utilizzo di 1 ora al giorno)</li> </ul>
<p><b>ES Ordenador CON CABLE:</b></p> <ul style="list-style-type: none"> <li>- Tipo de batería: CR 2032, 3V</li> <li>- Duración de la batería: 3 años (Con un uso de 1 hora diaria)</li> </ul>	<p><b>Ordenador INALÁMBRICO:</b></p> <ul style="list-style-type: none"> <li>- Tipo de batería: CR 2032, 3V</li> <li>- Duración de la batería: 2 años (Con un uso de 1 hora diaria)</li> </ul> <p><b>Transmisor:</b></p> <ul style="list-style-type: none"> <li>- Tipo de batería: CR 2032, 3V</li> <li>- Duración de la batería: 1,5 año (Con un uso de 1 hora diaria)</li> </ul>
<p><b>PT Computador COM FIOS:</b></p> <ul style="list-style-type: none"> <li>- Tipo de pilha: CR 2032, 3V</li> <li>- Vida útil da pilha: entre 3 anos (numa utilização de 1 hora por dia)</li> </ul>	<p><b>Computador SEM FIOS:</b></p> <ul style="list-style-type: none"> <li>- Tipo de pilha: CR 2032, 3V</li> <li>- Vida útil da pilha: 2 anos (numa utilização de 1 hora por dia)</li> </ul> <p><b>Transmissor:</b></p> <ul style="list-style-type: none"> <li>- Tipo de pilha: CR 2032, 3V</li> <li>- Vida útil da pilha: 1,5 anos (numa utilização de 1 hora por dia)</li> </ul>
<p><b>PL Komputer PRZEWODOWY:</b></p> <ul style="list-style-type: none"> <li>- Typ baterii: CR 2032, 3 V</li> <li>- Żywotność baterii: 3 lat (przy użytkowaniu przez 1 godzinę dziennie)</li> </ul>	<p><b>Komputer BEZPRZEWODOWY:</b></p> <ul style="list-style-type: none"> <li>- Typ baterii: CR 2032, 3 V</li> <li>- Żywotność baterii: 2 lat (przy użytkowaniu przez 1 godzinę dziennie)</li> </ul> <p><b>Nadajnik:</b></p> <ul style="list-style-type: none"> <li>- Typ baterii: CR 2032, 3 V</li> <li>- Żywotność baterii: 1,5 roku (przy użytkowaniu przez 1 godzinę dziennie)</li> </ul>
<p><b>NL Computer MET KABEL:</b></p> <ul style="list-style-type: none"> <li>- Batterijtype: CR 2032, 3V</li> <li>- Batterijduur: 3 jaar (Bij gebruik van 1 uur per dag)</li> </ul>	<p><b>Computer ZONDER KABEL:</b></p> <ul style="list-style-type: none"> <li>- Batterijtype: CR 2032, 3V</li> <li>- Batterijduur: 2 jaar (Bij gebruik van 1 uur per dag)</li> </ul> <p><b>Zender:</b></p> <ul style="list-style-type: none"> <li>- Batterijtype: CR 2032, 3V</li> <li>- Batterijduur: 1,5 jaar (Bij gebruik van 1 uur per dag)</li> </ul>
<p><b>CZ Computer S KABELOVÝM PŘIPOJENÍM:</b></p> <ul style="list-style-type: none"> <li>- Typ baterie: CR 2032, 3V</li> <li>- Životnost baterie: 3 roky (při používání 1 hodinu denně)</li> </ul>	<p><b>BEZDRÁTOVÝ computer:</b></p> <ul style="list-style-type: none"> <li>- Typ baterie: CR 2032, 3V</li> <li>- Životnost baterie: 2 roky (při používání 1 hodinu denně)</li> </ul> <p><b>Vysílač:</b></p> <ul style="list-style-type: none"> <li>- Typ baterie: CR 2032, 3V</li> <li>- Životnost baterie: 1,5 roku (při používání 1 hodinu denně)</li> </ul>

**EU-DECLARATION OF CONFORMITY**

We, SIGMA-ELEKTRO GmbH, Dr.-Julius-Leber-Str. 15, D-67433 Neustadt/Weinstraße declare under our responsibility that the product BC 10.0 WR are compliant with the essential requirements of the EMC Directive 2014/30/EU and the RoHS Directive 2011/65/EU. The declaration of conformity can be found at: [ce.sigmasport.com/bc100wr](http://ce.sigmasport.com/bc100wr)

We, SIGMA-ELEKTRO GmbH, Dr.-Julius-Leber-Str. 15, D-67433 Neustadt/Weinstraße declare under our responsibility that the product BC 10.0 WL and the transmitter ATS2021 are compliant with the essential requirements and other relevant requirements of the RED Directive 2014/53/EU and the RoHS Directive 2011/65/EU. The declaration of conformity can be found at: [ce.sigmasport.com/bc100wl](http://ce.sigmasport.com/bc100wl)

**EU-KONFORMITÄTSERKLÄRUNG**

Wir, SIGMA-ELEKTRO GmbH, Dr.-Julius-Leber-Str. 15, D-67433 Neustadt/Weinstraße, erklären, dass der Fahrradcomputer BC 10.0 WR bei bestimmungsgemäßer Verwendung den grundlegenden Anforderungen gemäß der EMC Directive 2014/30/EU und der RoHS Directive 2011/65/EU entspricht. Sie finden die Konformitäts-Erklärung unter folgendem Link: [ce.sigmasport.com/bc100wr](http://ce.sigmasport.com/bc100wr)

Wir, SIGMA-ELEKTRO GmbH, Dr. Julius Leber Str. 15, D-67433 Neustadt/Weinstraße erklären, dass der Fahrradcomputer mit Funkübertragung BC 10.0 WL und der Sender ATS2021 bei bestimmungsgemäßer Verwendung den grundlegenden Anforderungen gemäß RED Directive 2014/53/EU und der RoHS Directive 2011/65/EU entsprechen. Sie finden die Konformitäts-Erklärung unter folgendem Link: [ce.sigmasport.com/bc100wl](http://ce.sigmasport.com/bc100wl)

**LEGAL STATEMENTS**

**FEDERAL COMMUNICATION COMMISSION INTERFERENCE STATEMENT**

Caution: If any changes or modifications not expressly approved by the party responsible for compliance could void the user's authority to operate the equipment.

This device complies with Part 15 of the FCC Rules. Operation is subject to the following two conditions:  
(1) This device may not cause harmful interference, and  
(2) This device must accept any interference received, including interference that may cause undesired operation.

The grantee is not responsible for any changes or modifications not expressly approved by the party responsible for compliance. Such modifications could void the user's authority to operate the equipment.

The RF Exposure Compliance distance is 5 millimeters.

NOTE: This equipment has been tested and found to comply with the limits for a Class B digital device, pursuant to part 15 of the FCC Rules. These limits are designed to provide reasonable protection against harmful interference in a residential installation. This equipment generates, uses and can radiate radio frequency energy and, if not installed and used in accordance with the instructions, may cause harmful interference to radio communications. However, there is no guarantee that interference will not occur in a particular installation. If this equipment does cause harmful interference to radio or television reception, which can be determined by turning the equipment off and on, the user is encouraged to try to correct the interference by one or more of the following measures:

- Reorient or relocate the receiving antenna.
- Increase the separation between the equipment and receiver.
- Connect the equipment into an outlet on a circuit different from that to which the receiver is connected.
- Consult the dealer or an experienced radio/TV technician for help.

FCC ID ATS2021: M5LATS2021

**INDUSTRY CANADA STATEMENT**

This device complies with Innovation, Science and Economic Development Canada licence-exempt RSS standard(s).  
Operation is subject to the following two conditions:  
(1) this device may not cause interference, and  
(2) this device must accept any interference, including interference that may cause undesired operation of the device.

CAN ICES-3(B)/NMB-3(B)

Le présent appareil est conforme aux CNR Innovation, Sciences et Développement économique Canada applicables aux appareils radio exempts de licence.  
L'exploitation est autorisée aux deux conditions suivantes:  
(1) il ne doit pas produire de brouillage et  
(2) l'utilisateur du dispositif doit être prêt à accepter tout brouillage radioélectrique reçu, même si ce brouillage est susceptible de compromettre le fonctionnement du dispositif.

CAN ICES-3(B)/NMB-3(B)

The device meets the exemption from the routine evaluation limits in section 2.5 of RSS 102 and compliance with RSS-102 RF exposure, users can obtain Canadian information on RF exposure and compliance.

Le dispositif rencontre l'exemption des limites courantes d'évaluation dans la section 2.5 de RSS 102 et la conformité à l'exposition de RSS-102 rf, utilisateurs peut obtenir l'information canadienne sur l'exposition et la conformité de rf.

This transmitter must not be co-located or operating in conjunction with any other antenna or transmitter. This equipment should be installed and operated with a minimum distance of 5 millimeters between the radiator and your body.

Cet émetteur ne doit pas être Co-placé ou ne fonctionnant en même temps qu'aucune autre antenne ou émetteur. Cet équipement devrait être installé et actionné avec une distance minimum de 5 millimètres entre le radiateur et votre corps.

**UKCA STATEMENT**

**Wireless Model**

We, SIGMA-ELEKTRO GmbH, declare that the equipment above has been tested in our facility and found compliance with the requirement limits of applicable standards, in accordance with the Radio Equipment Regulations 2017 and the Restriction of the Use of Certain Hazardous Substances in Electrical and Electronic Equipment Regulations 2012. The test record, data evaluation and Equipment Under Test (EUT) configurations represented herein are true and accurate under the standards herein specified.

**Wired Model**

We, SIGMA-ELEKTRO GmbH, declare that the equipment above has been tested in our facility and found compliance with the requirement limits of applicable standards, in accordance with the Electromagnetic Compatibility Regulations 2016 and the Restriction of the Use of Certain Hazardous Substances in Electrical and Electronic Equipment Regulations 2012. The test record, data evaluation and Equipment Under Test (EUT) configurations represented herein are true and accurate under the standards herein specified.

**CE INFORMATION**

- EN** You can find the CE declaration at: [ce.sigmasport.com/bc100wr](http://ce.sigmasport.com/bc100wr)
- DE** Sie finden die Konformitäts-Erklärung unter folgendem Link: [ce.sigmasport.com/bc100wr](http://ce.sigmasport.com/bc100wr)
- FR** Vous trouverez la déclaration CE à l'adresse: [ce.sigmasport.com/bc100wr](http://ce.sigmasport.com/bc100wr)
- IT** La dichiarazione CE è disponibile all'indirizzo: [ce.sigmasport.com/bc100wr](http://ce.sigmasport.com/bc100wr)
- ES** Puede encontrar la declaración de conformidad CE en: [ce.sigmasport.com/bc100wr](http://ce.sigmasport.com/bc100wr)
- PT** Poderá encontrar a declaração CE em: [ce.sigmasport.com/bc100wr](http://ce.sigmasport.com/bc100wr)
- NL** U kunt de CE-certificering vinden op: [ce.sigmasport.com/bc100wr](http://ce.sigmasport.com/bc100wr)
- PL** Deklaracja CE znajduje się na stronie: [ce.sigmasport.com/bc100wr](http://ce.sigmasport.com/bc100wr)
- CZ** ES prohlášení najdete na adrese: [ce.sigmasport.com/bc100wr](http://ce.sigmasport.com/bc100wr)

## FUNCTIONS / SETTINGS

### BUTTON OVERVIEW

EN

SET Button: **S**

- Long press >3 sec. = Open/Close Settings
- Short press = SET/OK

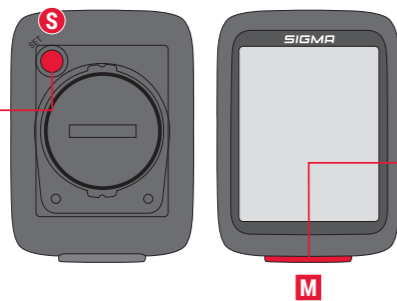

MENU Button: **M**

- Short press = Toggle/Increase value
- Long press >3 sec. = Reset tour data

### MENU BASIC BIKE FUNCTIONS



### DISPLAY OVERVIEW

EN

Higher/lower average speed

KMH or MPH selected

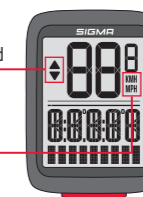

- DE** 1: Über/Unter Durchschnittsgeschwindigkeit; 2: KM/h oder MPH
- FR** 1: Vitesse moyenne plus élevée/plus basse; 2: KM/h ou MPH sélectionné
- IT** 1: Velocità media maggiore/minore; 2: KM/h o MPH selezionati
- ES** 1: Velocidad media mayor/menor; 2: Seleccionado Km/h o Mp/h
- PT** 1: Velocidade média superior/inferior; 2: KM/h ou MPH selecionado
- NL** 1: Hogere/lagere gemiddelde snelheid; 2: KM/h of MPH geselecteerd
- PL** 1: Wyższa/nizsza prędkość przeciętna; 2: Wybrano KM/H lub MPH
- CZ** 1: Vyšší/nížší průměrná rychlost; 2: Výběr KM/H nebo MILE/H

DE

S: SET-Taste:

- Lange drücken = Einstellungen öffnen/schließen
- Kurz drücken = SET/OK

M:MENU-Taste:

- Kurz drücken = Seite wechseln/Wert erhöhen
- Lange drücken = Tourdaten zurücksetzen

FR

S: Bouton SET :

- Pression prolongée = Ouvrir/fermer paramètres
- Pression brève = SET/OK

M: Bouton MENU :

- Pression brève = Changer de page/Augmenter valeur
- Pression prolongée = Réinitialiser données du tour

IT

S: Pulsante SET:

- Pressione prolungata = Aprire/chiudere impostazioni
- Pressione breve = SET/OK

M: Pulsante MENU:

- Pressione breve = Scorrere/aumentare il valore
- Pressione prolungata = Reset dati dell'escursione

ES

S: Botón SET:

- Pulsación prolongada = Abrir/cerrar ajustes
- Pulsación breve = SET/OK

M: Botón MENU:

- Pulsación breve = Cambiar /Aumentar el valor
- Pulsación prolongada = Resetear datos del recorrido

PT

S: Botão SET:

- Pressão longa = Abrir / Fechar Definições
- Pressão curta = DEFINIR / OK

M: Botão MENU:

- Pressão curta = Comutar / Aumentar valor
- Pressão longa = Repor dados de percurso

NL

S: SET-knop:

- Lang indrukken = Open/Sluit instellingen
- Kort indrukken = SET/OK

M: MENU-knop:

- Kort indrukken = Wisselen van waarde/Waarde verhogen
- Lang indrukken = Ritdata reset

PL

S: Przycisk SET:

- długie naciśnięcie = otwórz/zamknij Settings
- krótkie naciśnięcie = SET/OK

M: Przycisk MENU:

- krótkie naciśnięcie = przełącz/zwiększ wartość
- długie naciśnięcie = resetowanie danych trasy

CZ

S: Tlačítko SET:

- Dlouhé stisknutí = Otevření/zavření nastavení
- Krátké stisknutí = NASTAVIT/OK

M: Tlačítko MENU:

- Krátké stisknutí = Přepnutí / Zvýšení hodnoty
- Dlouhé stisknutí = Reset dat jízdy

### SETTINGS MENU

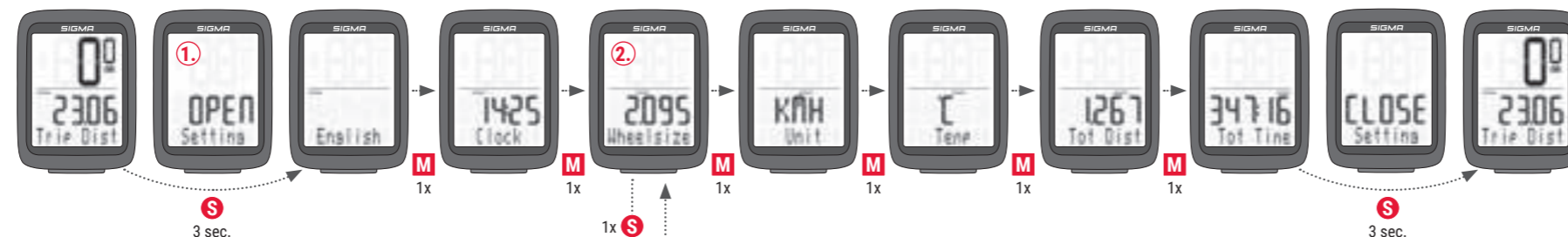

### EXAMPLE OF A SETTING

Setting the wheel size:



### CHOOSE YOUR SPECIFIC WHEEL SIZE / WÄHLE DEINE SPEZIFISCHE RAGRÖSSE

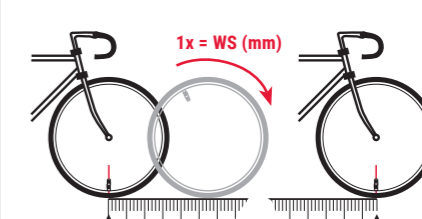

mm	inch
1253	49,3
1411	55,6
1590	62,6
1770	69,7
1907	75,1
2085	82,1
2195	86,4
2180	85,8
2200	86,6
2300	90,5
2095	82,5

km/h:

WS = mm

mph:

WS = mm

Note: 1 inch = 25.4 mm

EXAMPLE VALUE: 2135 mm

### EN EXAMPLE OF SETTING PROCEDURE:

1. **Open settings:** Press and hold **S** button > 3 sec. until settings open.
2. **Choose the relevant page:** Press **M** button until desired value is displayed.
3. **Open submenu:** Press 1x **S** button.
4. **Change value:** Press **M** button until desired value is displayed.
5. **Confirm chosen value:** Press 1x **S** button.  
Note: Do steps No. 4 and No. 5 until the submenu is closed „Set Ok”. You are now back in the Settings Menu.
6. **Close settings:** Press and hold **S** button > 3 sec.

### IT ESEMPIO DI PROCEDURA DI IMPOSTAZIONE:

1. **Aprire le impostazioni:** tenere premuto il pulsante **S** > 3 sec. finché non si aprono le impostazioni.
2. **Selezionare la pagina pertinente:** premere il pulsante **M** finché non viene visualizzato il valore desiderato.
3. **Aprire il sottomenu:** premere 1x il pulsante **S**.
4. **Modificare il valore:** premere il pulsante **M** finché non viene visualizzato il valore desiderato.
5. **Confermare il valore selezionato:** premere 1x il pulsante **S**.  
Nota: eseguire i passaggi n. 4 e n. 5 finché il sottomenu non si chiude „Set Ok”. Ora si è tornati al menu impostazioni.
6. **Chiudere le impostazioni:** tenere premuto il pulsante **S** > 3 sec.

### NL VOORBEELD VAN INSTELPROCEDURE:

1. **Open instellingen:** **S**-knop > 3 seconden ingedrukt houden totdat de instellingen openen.
2. **Kies de relevante waarde:** druk op de **M**-knop totdat de gewenste waarde wordt weergegeven.
3. **Open submenu:** druk 1 keer op de **S**-knop.
4. **Wijzig waarde:** druk op de **M**-knop totdat de gewenste waarde wordt weergegeven.
5. **Bevestig de gekozen waarde:** druk 1 keer op de **S**-knop.  
Opmerking: voer de stappen nr. 4 en nr. 5 uit totdat het submenu is gesloten „Set Ok”. Je bent nu terug in het instellingenmenu.
6. **Druk op instellingen:** houd de **S**-knop > 3 seconden ingedrukt.

### DE BEISPIEL EINSTELLVORGANG:

1. **Einstellungen öffnen:** Zum Öffnen der Einstellungen die **S**-Taste länger (> 3 Sek.) drücken.
2. **Die entsprechende Seite auswählen:** Die **M**-Taste solange drücken, bis der gewünschte Wert erscheint.
3. **Untermenü öffnen:** 1x **S**-Taste drücken.
4. **Wert ändern:** Die **M**-Taste drücken, bis der gewünschte Wert angezeigt wird.
5. **Den gewählten Wert bestätigen:** Die **S**-Taste 1x drücken.  
Anmerkung: Wiederholen Sie die Schritte 4 und 5, bis das Untermenü geschlossen ist „Set Ok”. Sie befinden sich nun wieder im Einstellungs Menü.
6. **Einstellungen schließen:** Die **S**-Taste länger (> 3 Sek.) drücken.

### ES EJEMPLO DE CÓMO SE AJUSTA:

1. **Abrir los ajustes:** pulsa y mantén pulsado el botón **S** > 3 seg. hasta que se abran los ajustes.
2. **Abrir una página específica:** pulsa el botón **M** hasta que se muestre el valor deseado.
3. **Abrir un submenú:** pulsa una vez el botón **S**.
4. **Cambiar valor:** pulsa el botón **M** hasta que aparezca el valor deseado.
5. **Confirmar el valor seleccionado:** pulsa una vez el botón **S**.  
Nota: completa los pasos n.º 4 y 5 hasta que se cierre el submenú „Set Ok”. Al hacerlo se volverá al menú de Ajustes.
6. **Cerrar ajustes:** pulsa y mantén pulsado el botón **S** durante > 3 seg.

### PL PRZYKŁAD PROCEDURY USTAWIANIA:

1. **Otwórz ustawienia:** naciśnij i przytrzymaj przycisk **S** przez ponad 3 sekundy do momentu otwarcia menu ustawień.
2. **Wybierz właściwą zakładkę:** naciskaj przycisk **M** do momentu wyświetlenia poszukiwanej wartości.
3. **Otwórz podmenu:** jeden raz naciśnij przycisk **S**.
4. **Zmień wartość:** naciskaj przycisk **M** do momentu wyświetlenia poszukiwanej wartości.
5. **Potwierdź wybraną wartość:** jeden raz naciśnij przycisk **S**.  
Uwaga: wykonuj kroki 4 i 5, aż podmenu zostanie zamknięte „Set Ok”. Znajdziesz się ponownie w menu ustawień.
6. **Zamknij ustawienia:** naciśnij i przytrzymaj przycisk **S** przez ponad 3 sekundy.

### FR EXEMPLE DE PROCÉDURE DE RÉGLAGE :

1. **Ouvrir les paramètres :** appuyer sur le bouton **S** et le maintenir enfoncé > 3 sec. jusqu'à ce que les paramètres s'ouvrent.
2. **Sélectionner la page concernée :** appuyer sur le bouton **M** jusqu'à ce que la page souhaitée s'affiche.
3. **Ouvrir le sous-menu :** appuyer 1x sur le bouton **S**.
4. **Modifier une valeur :** appuyer sur le bouton **M** jusqu'à ce que la valeur souhaitée s'affiche.
5. **Confirmer la valeur sélectionnée :** appuyer 1x sur le bouton **S**.  
Remarque : effectuer les étapes n° 4 et n° 5 jusqu'à ce que le sous-menu se ferme. « Set Ok ». Vous êtes à présent de retour ans le menu Paramètres.
6. **Fermer les paramètres :** appuyer sur le bouton **S** et le maintenir enfoncé > 3 sec.

### PT EXEMPLO DE PROCEDIMENTO DE DEFINIÇÃO:

1. **Abrir definições:** manter premido o botão **S** > 3 seg até abrirem as definições.
2. **Escolher a página relevante:** premir o botão **M** até o valor desejado ser exibido.
3. **Abrir submenu:** premir 1x o botão **S**.
4. **Alterar valor:** premir o botão **M** até o valor desejado ser exibido.
5. **Confirmar o valor selecionado:** premir 1x o botão **S**.  
Nota: execute os passos 4 e 5 até fechar o submenu „Set Ok”. Agora encontra-se novamente no Menu Definições.
6. **Fechar definições:** manter premido o botão **S** > 3 seg.

### CZ PŘÍKLAD POSTUPU NASTAVENÍ:

1. **Otevření nastavení:** Stiskněte a podržte tlačítko **S** po dobu > 3 s, dokud se nastavení neotevře.
2. **Volba příslušné stránky:** Mačkejte tlačítko **M**, dokud se neobjeví požadovaná hodnota.
3. **Otevření podmenu:** Stiskněte 1x tlačítko **S**.
4. **Změna hodnoty:** Mačkejte tlačítko **M**, dokud se neobjeví požadovaná hodnota.
5. **Potvrzení zvolené hodnoty:** Stiskněte 1x tlačítko **S**.  
Poznámka: Opakujte kroky 4 a 5, dokud se podmenu nezavře „Nastavení Ok”. Nyní jste zpět v menu Nastavení.
6. **Zavření nastavení:** Stiskněte a podržte tlačítko **S** po dobu > 3 s.

### BATTERY CHANGE

BC 10.0 WR/WL

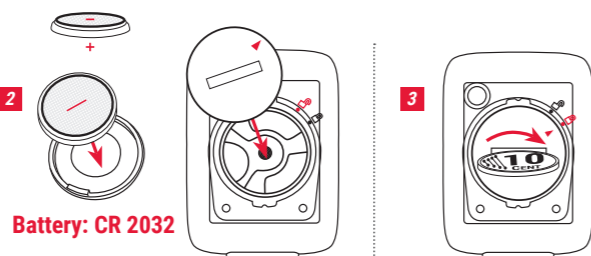

Battery: CR 2032

### SPEED TRANSMITTER (BC 10.0 WL)

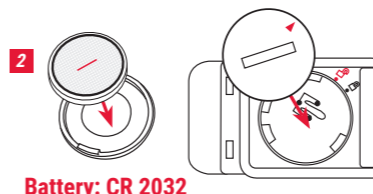
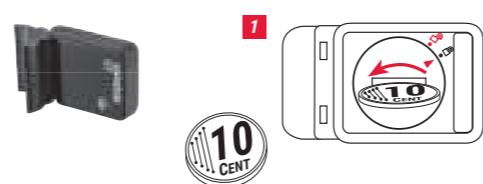

Battery: CR 2032

SIGMA-ELEKTRO GmbH  
Dr. Julius-Leber-Straße 15  
67433 Neustadt/Weinstraße, Germany  
kundenservice@sigmasport.com

