

Accessories of Mode C

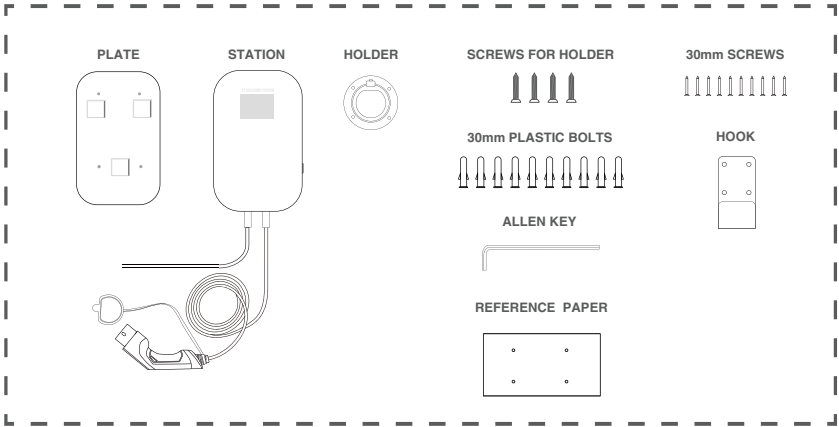

Mode C Station Overview

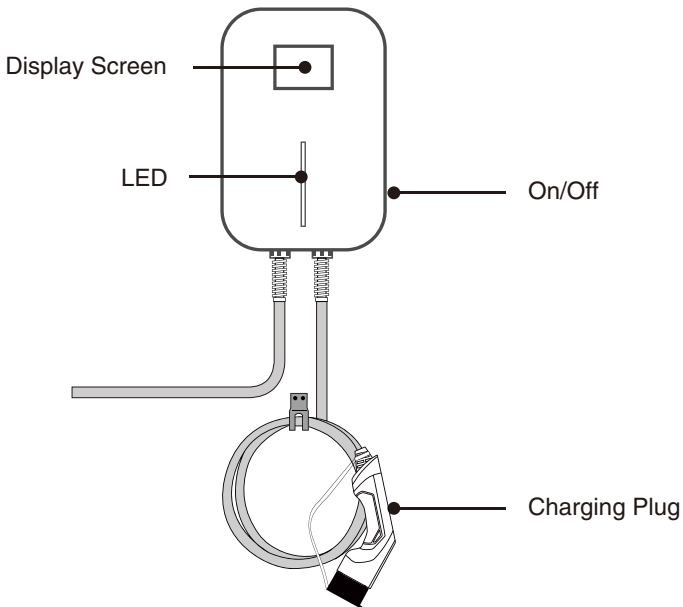

Level 2 EV Charging Station

Installation Method: Wall/Stand
 Mode: C(with plug)
 Certificate: TUV,CE
 IP Rating: IP66
 Rated Voltage: 230VAC±10%
 Rated Current: 16A
 Maximum Power: 11kw
 Phase Mode: Three Phase
 Operating Temperature: -40℃ ~ 55℃
 Enclosure Material: ABS+PC alloy
 Start Mode: Button(default)

Security Protection:
 Warning and display functions
 Open circuit protection
 Output overcurrent protection
 Input under voltage protection
 Over temperature protection
 Ground protection
 Input overvoltage protection
 Charge status detection

Instruction for Use

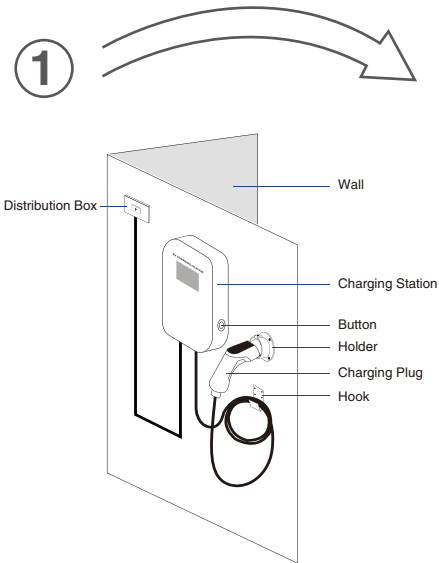

Make sure the wallbox is connected to power

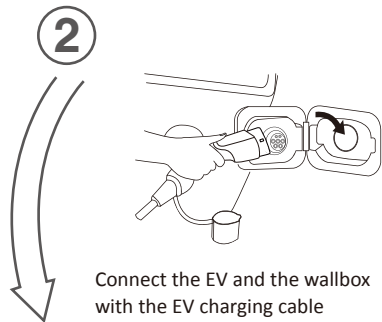

3

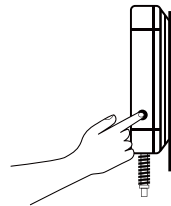

Press the button on the right side of the wallbox to start/stop charging

◆ Hang the cable on the hook when it is not in use

①

REFERENCE PAPER
of installing screw hole size

Wall

Drill the holes
according to the
REFERENCE PAPER

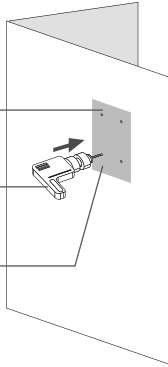

②

Hammer the
30mm PLASTIC BOLTS
into the holes

Take down the
REFERENCE PAPER
from the wall later

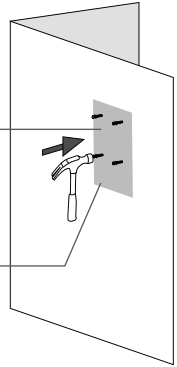

③

Fix the PLATE
with 30mm SCREWS
on the wall

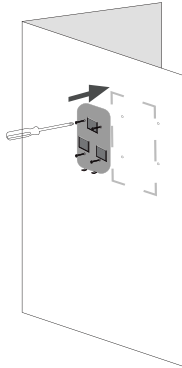

④

Embed STATION
into PLATE on the wall

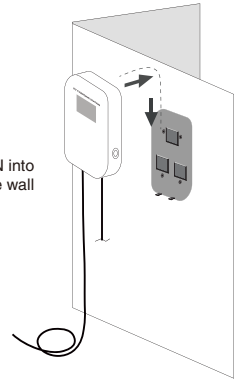

⑤

This is the final completion pic,
you can put the HOOK
and HOLDER
anywhere you need

The cable can
be hung on the
HOOK and HOLDER

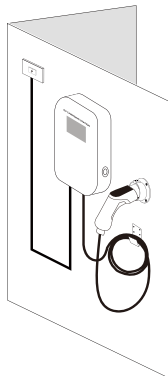

⑥

Tear off the protector

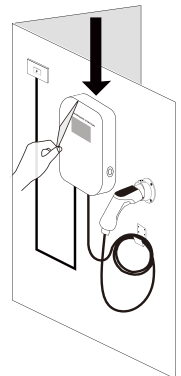

Accessories of Mode A

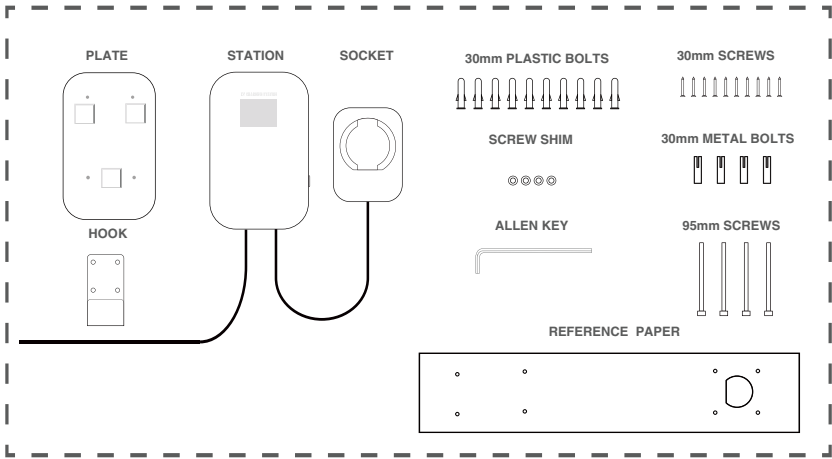

Mode A Station Overview

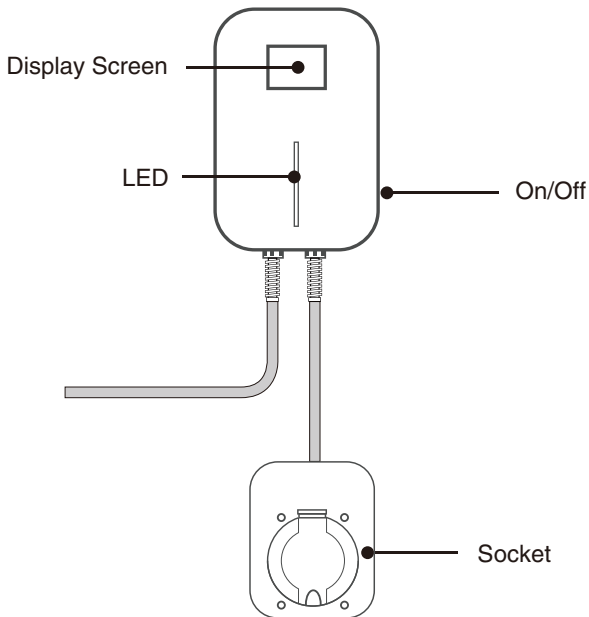

Level 2 EV Charging Station

Installation Method: Wall/Stand
 Mode: A(with socket)
 Certificate: TUV,CE
 IP Rating: IP66
 Rated Voltage: 230VAC±10%
 Rated Current: 16A
 Maximum Power: 11kw
 Phase Mode: Three Phase
 Operating Temperature: -40℃ to +55℃
 Enclosure Material: ABS+PC alloy
 Start Mode: Button(default)

Security Protection:
 Warning and display functions
 Open circuit protection
 Output overcurrent protection
 Input under voltage protection
 Over temperature protection
 Ground protection
 Input overvoltage protection
 Charge status detection

Instruction for Use

1

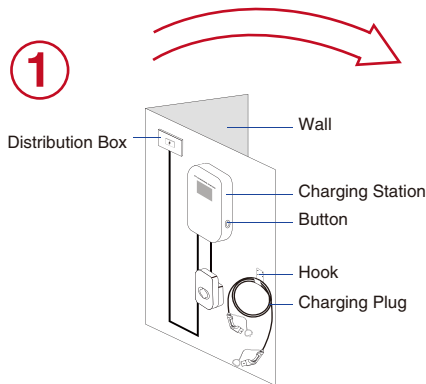

Make sure the walbox is connected to power

2

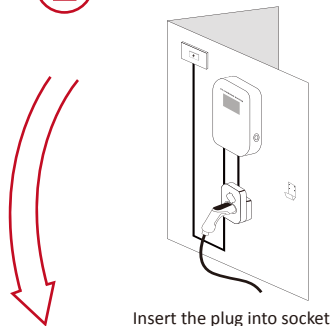

4

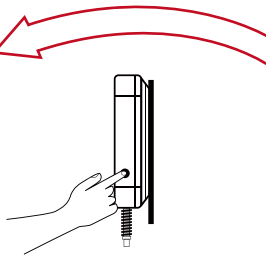

Press the button on the right side of the wallbox to start/stop charging

3

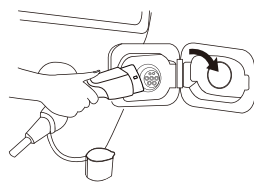

Connect the EV and the wallbox with the EV charging cable

◆ Hang the cable on the hook when it is not in use

1

REFERENCE PAPER
of installing screw hole size

Wall

Drill the holes according to
the REFERENCE PAPER

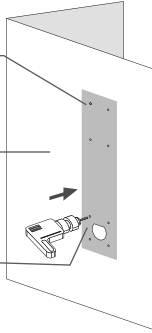

2

Hammer the
30mm PLASTIC BOLTS
into the holes

Hammer the
30mm METAL BOLTS
into the holes

Take down the
REFERENCE PAPER
from the wall later

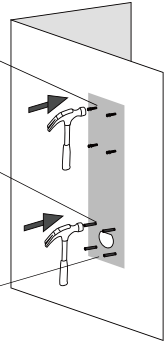

3

Fix the PLATE with
30mm SCREWS on the wall

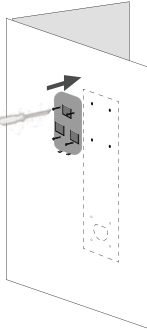

4

Embed STATION
into PLATE on the wall

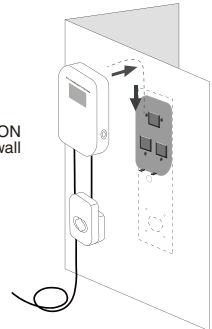

5

Take out the plate from
the body of charging
SOCKET

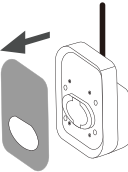

6

Fix the SOCKET on the wall
with 95mm SCREWS
by ALLEN KEY
and put the plate back to the
body of SOCKET

95mm SCREWS

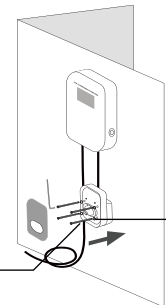

7

Connect the inlet cable and
the power supply correctly

This is the final completion pic,
you can put the HOOK
anywhere you need

The cable can be hung on the
HOOK

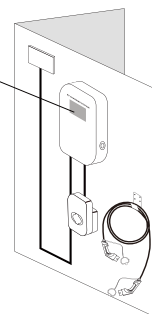

8

Tear off the protector

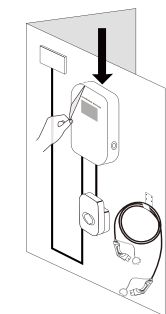



Start-up screen
(the version no. is for reference only)



Wait for inserting the plug



Wait for identification



Wait for the car to be ready



During charging process



Stop charging and wait for pulling out the plug



- 1.Real-time power
- 2.Three Live Wire data
- 3.Charging time
- 4.Power consumption
- 5.Charging icon
- 6.PCB Temperature



Possible fault warning

- 1.Emergency stop
- 2.Over Current
- 3.Over Temperature
- 4.Leakage protection
- 5.Short Current

	IDLE	CONNECTED	CHARGING	FINISHED	ERROR
Instruction of LED Status	OFF	Continuous light	Rolling	Continuous light	Red flashing

Note: When small problems like short current occur, the wallbox will automatically restart to repair and continue charging.

For serious failures, the system can not automatically recover, in order to remind the user of this failure, after the user pulls the plug, the system will automatically countdown 10 seconds to restart

Security Warning

Failure to follow instructions may result in danger!

- ▲ Regularly check whether the charging station has visible damage. There may be a electric shock when operating the broken charging station.
- ▲ Make sure that all safety facilities are available at all times and are tested regularly to ensure they can operate normally.
- ▲ If a ground fault occurs, it must be assumed that the cable carries voltage. Please confirm that there's no high-voltage power in the system before inspecting the charging station.
- ▲ Persons who install and use charging stations must obey the principles and regulations mentioned to ensure the personal safety and equipment safety.
- ▲ Before powering on the device, please confirm that the device is properly grounded to avoid unnecessary accidents.
- ▲ All tools' unnecessarily exposed metal parts should be insulated to prevent them from touching the metal frame to avoid short circuit.
- ▲ Do not modify, retrofit, or change any part by yourself under any circumstances.
- ▲ To ensure the service life and stable operation of the charging station, the operating environment should be kept as clean as possible with a relatively stable temperature and humidity. The charging station must not be used in flammable environment or environments with volatile gas.
- ▲ Be sure to confirm that the input voltage, frequency, circuit breakers and other conditions of the device meet the specifications before the device is powered on.

Maintenance & Overhaul

In order to ensure the normal service life of the charging station and reduce risk, maintenance must be performed within the specified time. The maintenance of the equipment must be completed by professionals with qualified and safe maintenance tools.

The product is already packed in factory. During transportation, strong impact and bumps should be avoided to avoid damage to the outer packaging of the product.

The product should be placed at an ambient temperature of $-40\text{ }^{\circ}\text{C} \sim 55\text{ }^{\circ}\text{C}$ with a relative humidity of no more than 95%. The air should not contain acids, alkalis or other corrosive gases and explosive gases.

AC charging stations are subject to stringent quality inspections. Mode 2 Charging is subject to stringent quality inspections. From the day of purchase, any problem of product quality can be reflected to the dealer within two years.

Any direct damage or malfunction caused by neglect, incorrect use, installation, usage, repair by the users or natural damage are not covered by the warranty.

MANUFACTURER

Nanjing LuAo international tradeCo.,Ltd.

+86-025-8662-3210

No.128,Aoti,Jianye District, Nanjing, Jiangsu, China

(Please do not contact the manufacturer's phone for after-sales questions)

Zubehör für Modus C

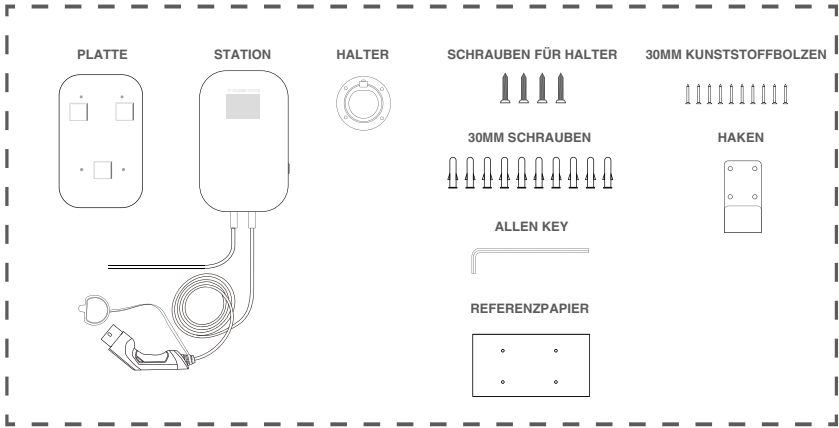

Modus C Station Übersicht

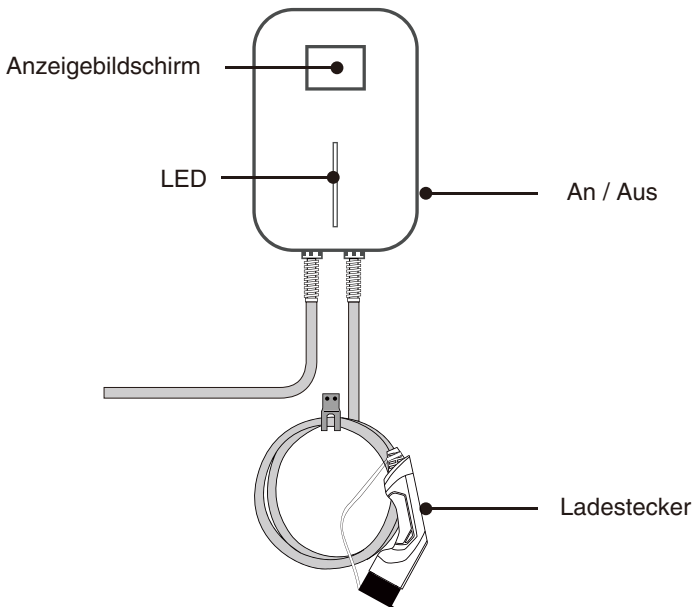

Ladestation für Stufe 2 EV

Installationsmethode: Wand / Pol
 Modus: C (mit Stecker)
 Zertifikat: TÜV, CE
 IP66
 Spannungsbereich: 230V ± 10%
 Betriebsstrom: 16Amp
 Maximale Leistung: 11KW
 Phasenmodus: Einzelphase
 Betriebstemperatur: -40°C ~ 55°C
 Schalenmaterial: ABS+PC Legierung
 Startmodus: Schaltfläche (Standardeinstellung)

Sicherheitsschutz:
 Warn- und Anzeigefunktionen
 Kurzschlusschutz
 Schutz für Ausgangsüberstrom
 Eingang unter Spannungsschutz
 Übertemperaturschutz
 Bodenschutz
 Schutz für Eingangsüberspannung
 Erkennung des Ladezustandes

Bedienungsanleitung

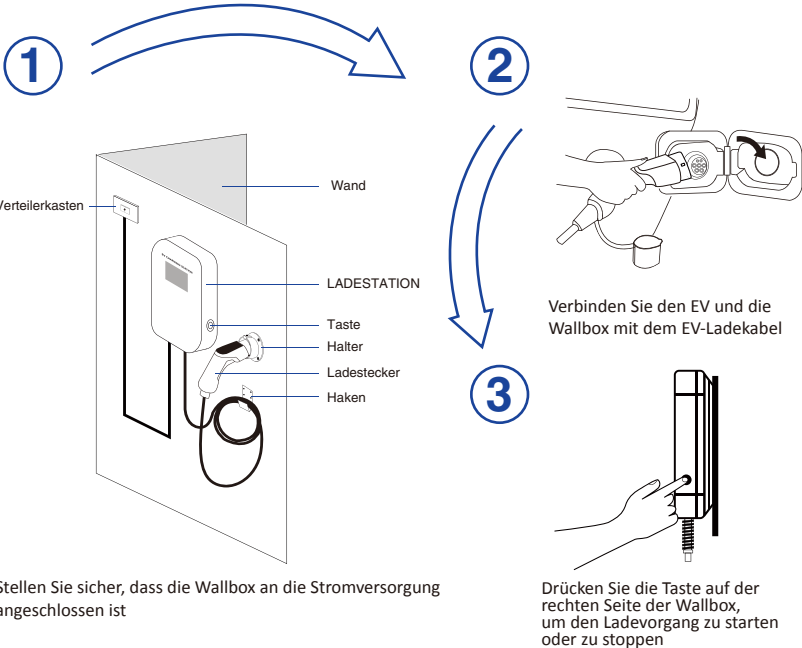

◆ Hängen Sie das Kabel an den Haken, wenn es nicht verwendet wird

1

REFERENZPAPIER
für die Größe der
Befestigungsbohrung

Die Wand

Bohren Sie die
Löcher gemäß dem
REFERENZPAPIER

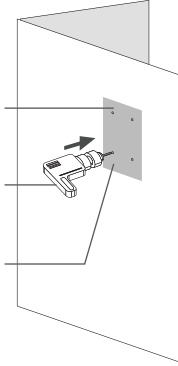

2

Hämmern Sie die
30mm KUNSTSTOFFBOLZEN
in die Löcher

Nehmen Sie das
REFERENZPAPIER
von der Wand ab

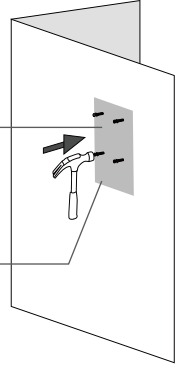

3

Befestigen Sie die
PLATTE
mit 30mm SCREWS
an der Wand

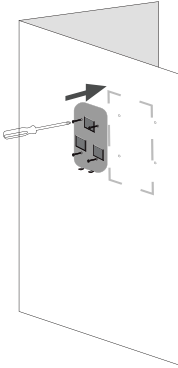

4

Mit STATION in die
PLATTE
an der Wand einbetten

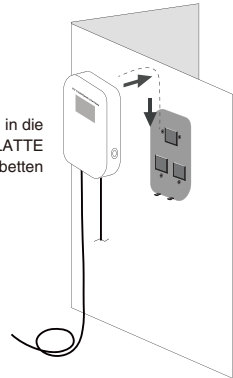

5

Dies ist das letzte fertige Bild,
Sie können den Haken
und den Halter
an jedem beliebigen
Ort installieren

Das Kabel kann am
HAKEN und HALTER
aufgehängt werden

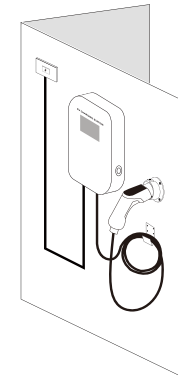

6

Entfernen Sie den
Schutzfilm

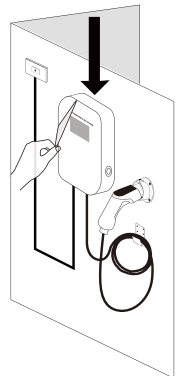

Accessories of Mode A

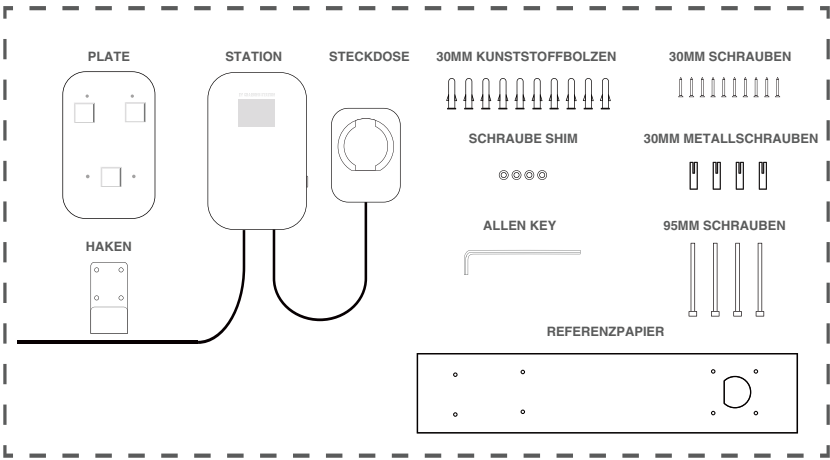

Modus A Station Übersicht

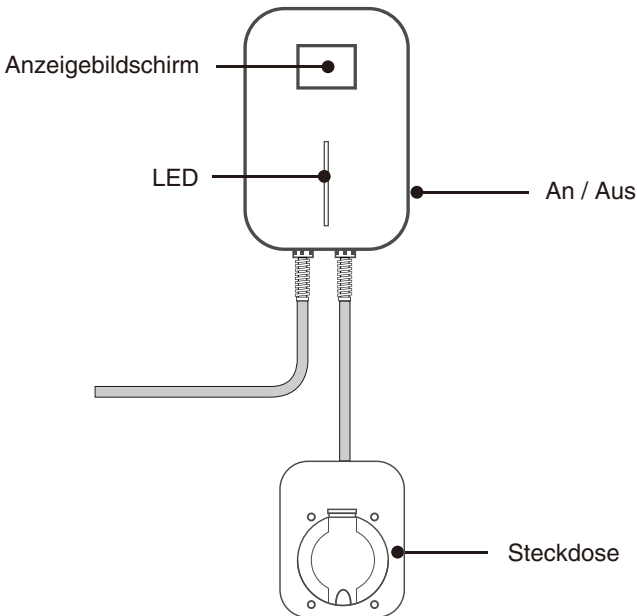

Ladestation für Stufe 2 EV

Installationsmethode: Wand / Pol
 Modus: A (mit Sockel)
 Zertifikat: TÜV, CE
 IP66
 Spannungsbereich: 230V ± 10%
 Betriebsstrom: 16Amp
 Maximale Leistung: 11 KW
 Phasenmodus: Einzelphase
 Betriebstemperatur: -40°C ~+ 55°C
 Schalenmaterial: ABS+PC Legierung
 Startmodus: Schaltfläche (Standardeinstellung)

Sicherheitsschutz:
 Warn- und Anzeigefunktionen
 Kurzschlusschutz
 Schutz für Ausgangsüberstrom
 Eingang unter Spannungsschutz
 Übertemperaturschutz
 Bodenschutz
 Schutz für Eingangsüberspannung
 Erkennung des Ladezustandes

Bedienungsanleitung

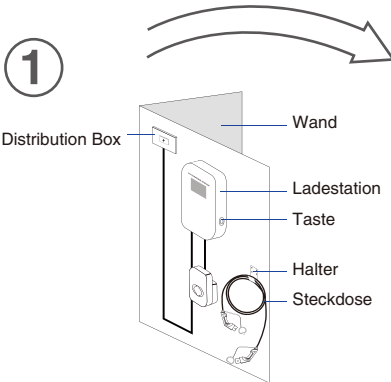

Stellen Sie sicher, dass die Wallbox an die Stromversorgung angeschlossen ist

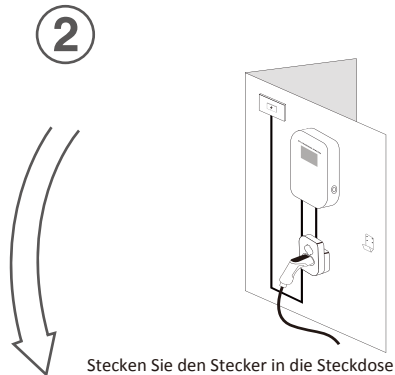

Stecken Sie den Stecker in die Steckdose

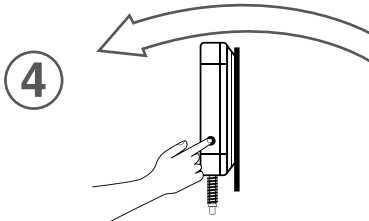

Drücken Sie die Taste auf der rechten Seite der Wallbox, um den Ladevorgang zu starten oder zu stoppen

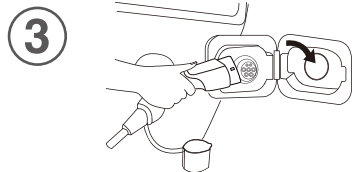

Verbinden Sie den EV und die Wallbox mit dem EV-Ladekabel

◆ Hängen Sie das Kabel an den Haken, wenn es nicht verwendet wird

1

REFERENZPAPIER
für die Größe der
Befestigungsbohrung

Die Wand

Bohren Sie die Löcher
gemäß dem
REFERENZPAPIER

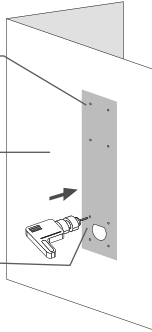

2

Hämmern Sie die
30mm KUNSTSTOFFBOLZEN
in die Löcher

Hämmern Sie die
30mm METALLSCHRAUBEN
in die Löcher

Nehmen Sie das
REFERENZPAPIER
von der Wand ab

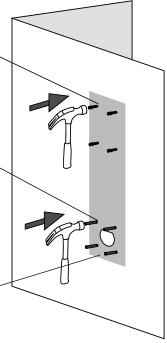

3

Befestigen Sie die
PLATTE mit
30mm SCHRAUBEN
an der Wand

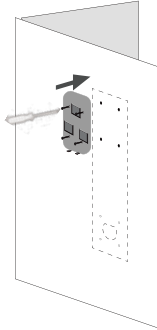

4

Mit STATION
into die PLATTE
an der Wand einbetten

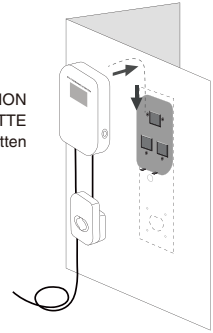

5

Nehmen Sie die PLATTE aus
dem Gehäuse der
STECKDOSE heraus

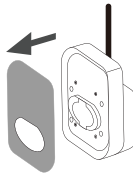

6

Befestigen Sie die STECKDOSE
an der Wand mit 95mm SCREWS
von ALLEN KEY und setzen
Sie die Platte wieder auf den
Gehäuse von STECKDOSE

95MM SCHRAUBEN

SCHRAUBE
SHIM

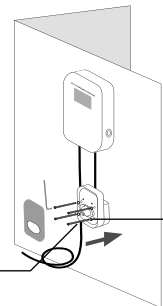

7

Schließen Sie das
Einlass-Kabel und die
Stromversorgung korrekt an

Dies ist das letzte fertige Bild,
Sie können den Haken an jedem
beliebigen Ort installieren

Das Kabel kann am HAKEN
aufgehängt werden

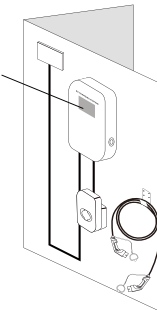

8

Entfernen Sie den Schutzfilm

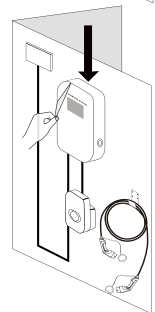



Startbildschirm
(die Versionsnummer dient nur als Referenz)



Sie können zum Einsetzen des Steckers warten



Sie können auf die Identifizierung warten



Sie können warten, bis das Auto fertig ist



Während des Ladevorgangs



Beenden Sie den Ladevorgang und warten Sie Stecker ziehen







1. Echtzeitleistung
2. Drei Live-Wire-Daten
3. Ladezeit
4. Stromverbrauch
5. Lade-Icon
6. PCB-Temperatur



Possible fault warning

1. Not-Aus
2. Überstrom
3. Übertemperatur
4. Auslaufschutz
5. Kurzer Strom

	LEERLAUF	IN VERBINDUNG GEBRACHT	LADEN	FERTIG	ERROR
Anweisung des LED-Status	 AUS	 Kontinuierlich Licht	 Rollen	 Kontinuierlich Licht	 Rot Blinkt

Hinweis: Wenn kleine Probleme auftreten, wie z. B. ein kurzer Strom, wird die Wallbox automatisch neu gestartet, um zu reparieren und den Ladevorgang fortzusetzen.

Bei schwerwiegenden Fehlern kann das System nicht automatisch wiederhergestellt werden. Um den Benutzer an diesen Fehler zu erinnern, zählt das System nach dem Ziehen des Ladesteckers automatisch 10 Sekunden zum Neustart herunter

Nichtbeachtung der Anweisungen kann zu Gefahr führen!

- ▲ Prüfen Sie regelmäßig, ob die Ladestation sichtbare Schäden aufweist. Beim Betrieb der defekten Ladestation kann ein elektrischer Schlag auftreten.
- ▲ Stellen Sie sicher, dass alle Sicherheitseinrichtungen jederzeit verfügbar sind und regelmäßig getestet werden, um sicherzustellen, dass sie normal funktionieren.
- ▲ Wenn ein Erdschluss auftritt, muss davon ausgegangen werden, dass das Kabel Spannung führt. Vergewissern Sie sich vor der Überprüfung der Ladestation, dass sich im System keine Hochspannung befindet.
- ▲ Personen, die Ladestationen installieren und verwenden, müssen die genannten Grundsätze und Vorschriften befolgen, um die persönliche Sicherheit und die Gerätesicherheit zu gewährleisten.
- ▲ Bevor Sie das Gerät einschalten, vergewissern Sie sich, dass das Gerät ordnungsgemäß geerdet ist, um unnötige Unfälle zu vermeiden.
- ▲ Alle Werkzeuge, die unnötig freiliegenden Metallteilen ausgesetzt sind, sollten isoliert werden, damit sie den Metallrahmen nicht berühren, um einen Kurzschluss zu vermeiden.
- ▲ Nehmen Sie unter keinen Umständen die Möglichkeit vor, Teile selbst zu verändern, nachzurüsten oder zu verändern.
- ▲ Um die Lebensdauer und einen stabilen Betrieb der Ladestation sicherzustellen, sollte die Betriebsumgebung bei relativ stabiler Temperatur und Luftfeuchtigkeit so sauber wie möglich gehalten werden. Die Ladestation darf nicht in entflammaren Umgebungen oder Umgebungen mit flüchtigem Gas verwendet werden.
- ▲ Vergewissern Sie sich, dass Eingangsspannung, Frequenz, Schutzschalter und andere Bedingungen des Geräts den Spezifikationen entsprechen, bevor Sie das Gerät einschalten.

Wartung & Überholung

AC-Ladestationen unterliegen strengen Qualitätskontrollen. Modus 2 Die Aufladung unterliegt strengen Qualitätskontrollen. Ab dem Tag des Kaufs kann jedes Problem der Produktqualität innerhalb von zwei Jahren beim Händler reflektiert werden.

Jegliche direkte Beschädigung oder Fehlfunktion, die durch Vernachlässigung, falsche Verwendung, Installation, Verwendung, Reparatur durch den Benutzer oder natürliche Schäden verursacht wurde, sind nicht von der Garantie abgedeckt.

Um die normale Lebensdauer der Ladestation zu gewährleisten und das Nutzungsrisiko zu verringern, muss die Wartung innerhalb der angegebenen Zeit durchgeführt werden; die Wartung der Geräte muss von Fachleuten durchgeführt werden, und der Einsatz von qualifizierten und sicheren Werkzeugen.

Das Produkt ist bereits im Werk verpackt, und während des Transports sollten starke Stöße und anderen Stöße vermieden werden, um Schäden an der Außenverpackung des Produkts zu vermeiden. Das Produkt sollte bei einer Umgebungstemperatur von $-40^{\circ}\text{C} \sim 55^{\circ}\text{C}$ und einer relativen Luftfeuchtigkeit von nicht mehr als 95% gelagert werden. Die Umgebungsluft sollte keine Säuren, Laugen oder andere korrosive Gase und explosive Gase enthalten und vor Schnee, Wind und Sand geschützt sein.

MANUFACTURER

Nanjing LuAo international tradeCo.,Ltd.

+86-025-8662-3210

No.128,Aoti,Jianye District, Nanjing, Jiangsu, China

(Bitte wenden Sie sich bei Fragen zum Kundendienst nicht an das Telefon des Herstellers)

Accessoires du mode C

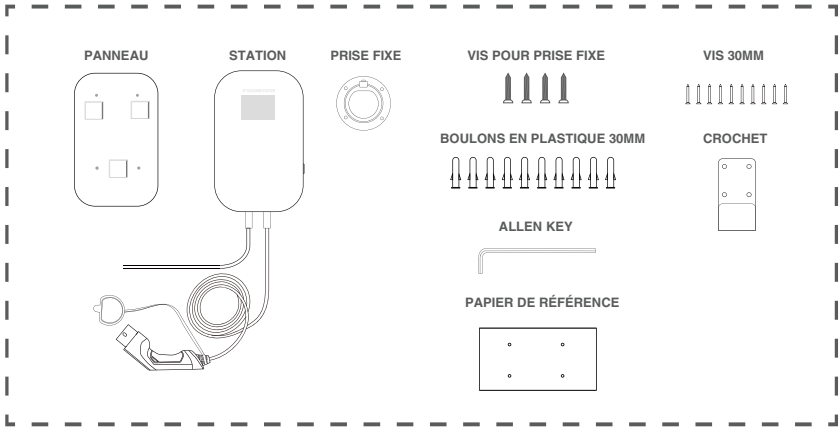

Présentation de la STATION Mode C

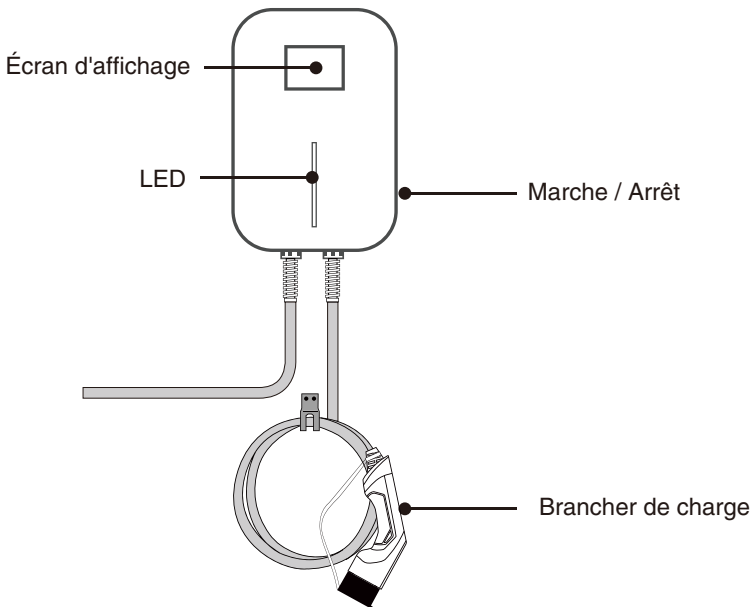

Station de recharge EV niveau 2

Méthode d'installation: mur / poteau

Mode: C (avec Brancher)

Certificat : TUV, CE

IP66

Gamme de tension : 230V \pm 10%

Courant de fonctionnement : 16Amp

Puissance maximale : 11KW

Mode phase: Monophasé

Température de travail : -40 ° C \sim 55 ° C

Matériau du boîtier: ABS + Alliage PC

Mode de démarrage: bouton (par défaut)

Protection de la sécurité:

Fonctions d'avertissement et d'indication

Protection de court circuit

Protection contre les surintensités de sortie

Protection d'entrée sous tension

Protection contre la surchauffe

Protection du sol

Protection contre les surtensions d'entrée

Détection de l'état de charge

Instruction d'utilisation

1

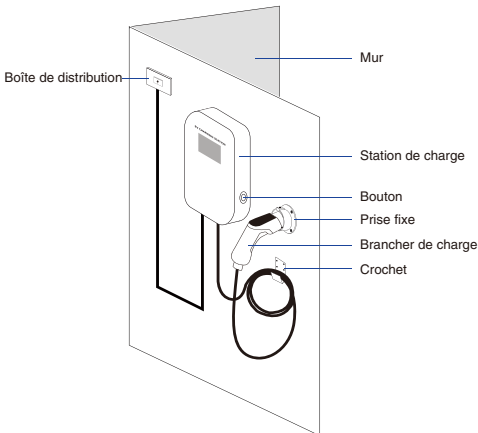

Assurez-vous que la wallbox est connectée à l'alimentation

2

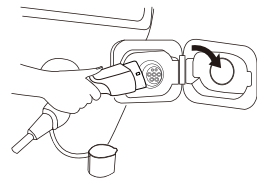

Reliez le VE et le wallbox avec le câble de chargement du VE

3

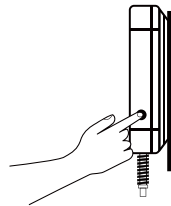

Appuyez sur le bouton situé sur le côté droit de la wallbox pour démarrer / arrêter le chargement

◆ Accrocher le câble au crochet lorsque vous ne l'utilisez pas

1

PAPIER DE RÉFÉRENCE
de la taille du trou de vis

Mur

Percer les trous selon le
PAPIER DE RÉFÉRENCE

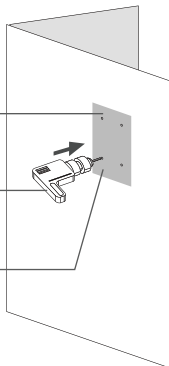

2

Enfoncez les BOULONS
EN PLASTIQUE de
30 mm dans les trous

Retirez le PAPIER DE
RÉFÉRENCE du mur

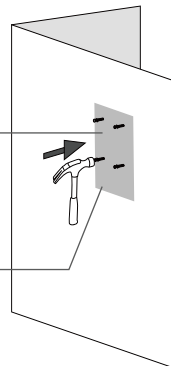

3

Fixer le PANNEAU au
mur avec des VIS DE 30mm

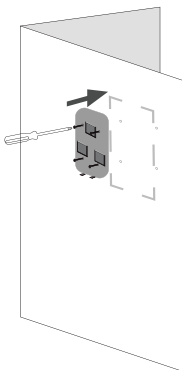

4

Installer STATION sur
le panneau dans le mur

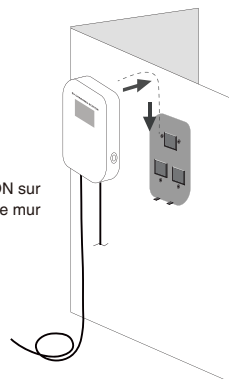

5

Ceci est la dernière
image terminée,
vous pouvez installer le
CROCHET et le PRISE FIXE
où vous voulez

Le câble peut être
suspendu au CROCHET
et au PRISE FIXE

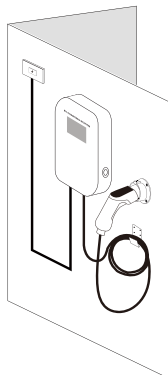

6

Retirer le film
protecteur



Accessoires du mode A

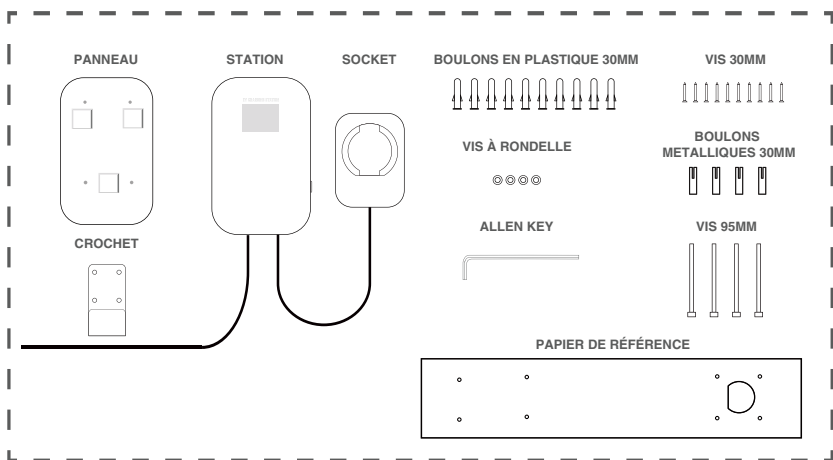

Présentation de la STATION Mode A

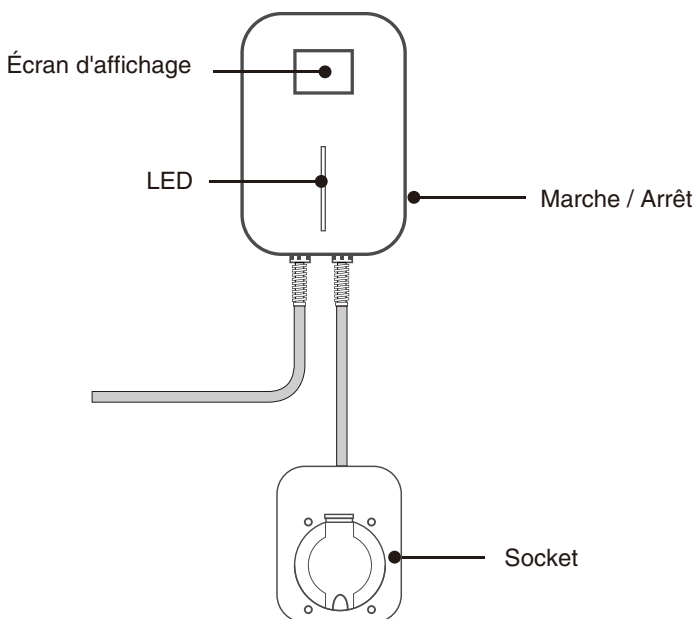

Station de recharge EV niveau 2

Méthode d'installation: mur / poteau
 Mode: A (avec Socket)
 Certificat : TUV, CE
 IP66
 Gamme de tension : 230V ± 10%
 Courant de fonctionnement : 16Amp
 Puissance maximale : 11KW
 Mode phase: Monophasé
 Température de travail : -40 ° C ~ + 50 ° C
 Matériau du boîtier: ABS + Alliage PC
 Mode de démarrage: bouton (par défaut)

Protection de la sécurité:
 Fonctions d'avertissement et d'indication
 Protection de court circuit
 Protection contre les surintensités de sortie
 Protection d'entrée sous tension
 Protection contre la surchauffe
 Protection du sol
 Protection contre les surtensions d'entrée
 Détection de l'état de charge

Instruction d'utilisation

1

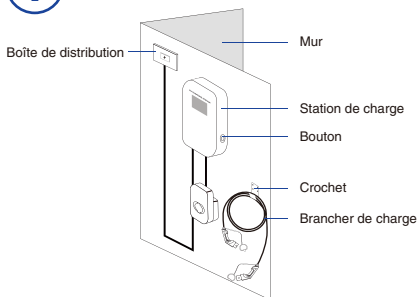

Assurez-vous que la wallbox est connectée à l'alimentation

2

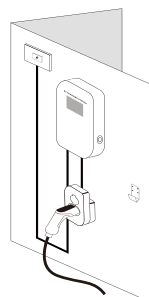

Insérez la fiche dans la prise

4

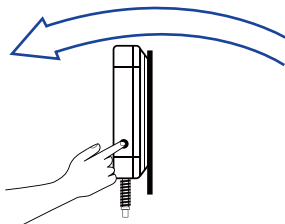

Appuyez sur le bouton situé sur le côté droit de la wallbox pour démarrer / arrêter le chargement

3

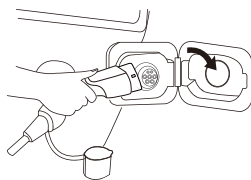

Reliez le VE et le wallbox avec le câble de chargement du VE

◆ Accrocher le câble au crochet lorsque vous ne l'utilisez pas

1

PAPIER DE RÉFÉRENCE
de la taille du trou de vis

Mur

Percer les trous selon le
PAPIER DE RÉFÉRENCE

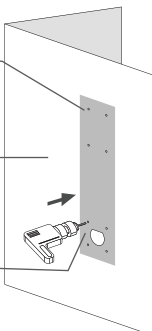

2

Enfoncez les BOULONS EN
PLASTIQUE de
30 mm dans les trous

Enfoncez les BOULONS
MÉTALLIQUES de
30 mm dans les trous

Retirez le PAPIER DE
RÉFÉRENCE du mur

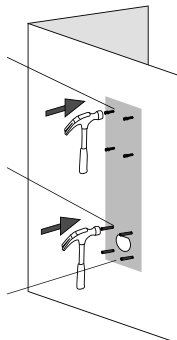

3

Fixer le PANNEAU au mur
avec des VIS DE 30mm

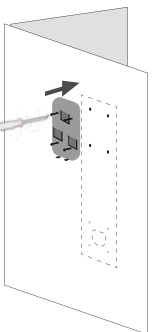

4

Installer STATION sur le
panneau dans le mur

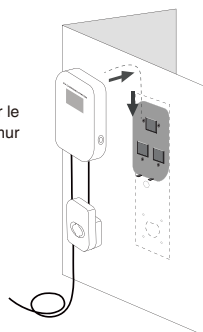

5

Retirer la plaque du corps
de la prise de charge

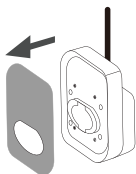

6

Installer la vis 95mm sur
SOCKET en utilisant
ALLEN KEY remettre le
PANNEAU au corps de
SOCKET

VIS 95MM

VIS À
RONDELLE

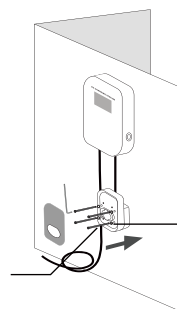

7

Raccorder le câble d'entrée
et l'alimentation correctement

Ceci est la dernière
image terminée,
vous pouvez mettre le CROCHET
partout où vous avez besoin

Le câble peut être accroché
au CROCHET

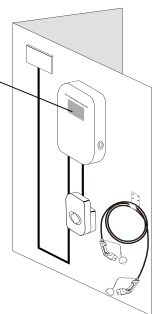

8

Retirer le film protecteur

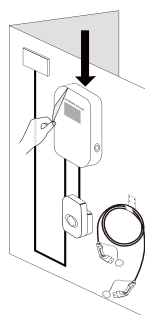



Écran de démarrage
(le numéro de version est pour référence seulement)



Attendre l'insertion de la fiche



Attendre l'identification



Attendez que la voiture
soit prête



Pendant le processus
de charge



Arrêtez de charger et attendez
débrancher le bouchon



1. Pouvoir en temps réel
2. Trois données de fil en direct
3. Temps de charge
4. Consommation d'énergie
5. Icône de charge
6. Température de la PCB



Possible
fault warning

1. Arrêt d'urgence
2. Surintensité
3. Température excessive
4. Protection contre les fuites
5. Courant court

	TOURNER AU RALENTI	CONNECTÉ	EN CHARGE	FINI	ERREUR
Instruction de l'état de la LED	DE	Continu lumière	Roulant	Continu lumière	Rouge clignotant

Remarque: lorsque de petits problèmes tels qu'un courant insuffisant surviennent, la wallbox redémarre automatiquement pour réparer et continuer à charger.

En cas de défaillance grave, le système ne peut pas récupérer automatiquement. Afin de rappeler à l'utilisateur cette défaillance, une fois que l'utilisateur a retiré la fiche de chargement, le système compte à rebours automatique pendant 10 secondes.

Ne pas suivre les instructions peut entraîner un danger!

- ▲ Vérifiez régulièrement si la station de charge présente des dommages visibles. Il peut y avoir un choc électrique lors de l'utilisation de la station de charge cassée.
- ▲ Assurez-vous que toutes les installations de sécurité sont disponibles à tout moment et sont régulièrement testées pour vous assurer qu'elles fonctionnent normalement.
- ▲ Si un défaut à la terre se produit, il faut supposer que le câble est sous tension. Vérifiez que le système n'a pas d'alimentation haute tension avant d'inspecter la station de charge.
- ▲ Les personnes qui installent et utilisent des stations de charge doivent respecter les principes et les réglementations mentionnés pour garantir la sécurité des personnes et des équipements.
- ▲ Avant de mettre l'appareil sous tension, assurez-vous qu'il est correctement mis à la terre pour éviter les accidents inutiles.
- ▲ Toutes les pièces métalliques inutilement exposées des outils doivent être isolées pour éviter qu'elles ne touchent le cadre métallique et éviter les courts-circuits.
- ▲ Ne modifiez, modernisez ou modifiez aucune pièce par vous-même, quelles que soient les circonstances.
- ▲ Pour assurer la durée de vie et le fonctionnement stable de la station de charge, l'environnement d'exploitation doit être maintenu aussi propre que possible avec une température et une humidité relativement stables. La station de charge ne doit pas être utilisée dans des environnements inflammables ou des environnements contenant des gaz volatils.
- ▲ Assurez-vous que la tension d'entrée, la fréquence, les disjoncteurs et les autres conditions de l'appareil sont conformes aux spécifications avant sa mise sous tension.

Maintenance et révision

Les stations de charge en courant alternatif sont soumises à des inspections de qualité rigoureuses. Mode 2 La charge est soumise à des contrôles de qualité rigoureux. Dès le jour de l'achat, tout problème de qualité du produit peut être signalé au revendeur dans les deux ans.

Tout dommage direct ou tout dysfonctionnement causé par négligence, utilisation incorrecte, installation, utilisation, réparation par l'utilisateur ou tout dommage naturel ne sont pas couverts par la garantie.

Afin de garantir la durée de vie normale de la station de charge et de réduire les risques, une maintenance doit être effectuée dans les délais spécifiés. La maintenance de l'équipement doit être effectuée par des professionnels disposant d'outils de maintenance qualifiés et sûrs.

Le produit est déjà emballé en usine. Pendant le transport, il convient d'éviter les chocs et les chocs violents afin d'éviter d'endommager l'emballage extérieur du produit.

Le produit doit être placé à une température ambiante de $-40 \sim 55$ avec une humidité relative de 95% au maximum. L'air ne doit contenir ni acides, ni bases, ni autres gaz corrosifs et explosifs.

MANUFACTURER

Nanjing LuAo international tradeCo.,Ltd.

+86-025-8662-3210

No.128,Aoti,Jianye District, Nanjing, Jiangsu, China

(S'il vous plaît ne pas contacter le téléphone du fabricant pour des questions après-vente)

Accesorios de Modo C

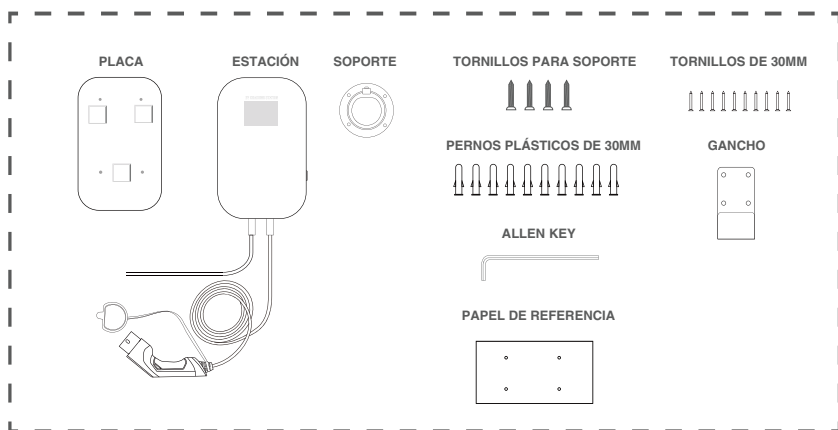

Resumen de la estación Modo C

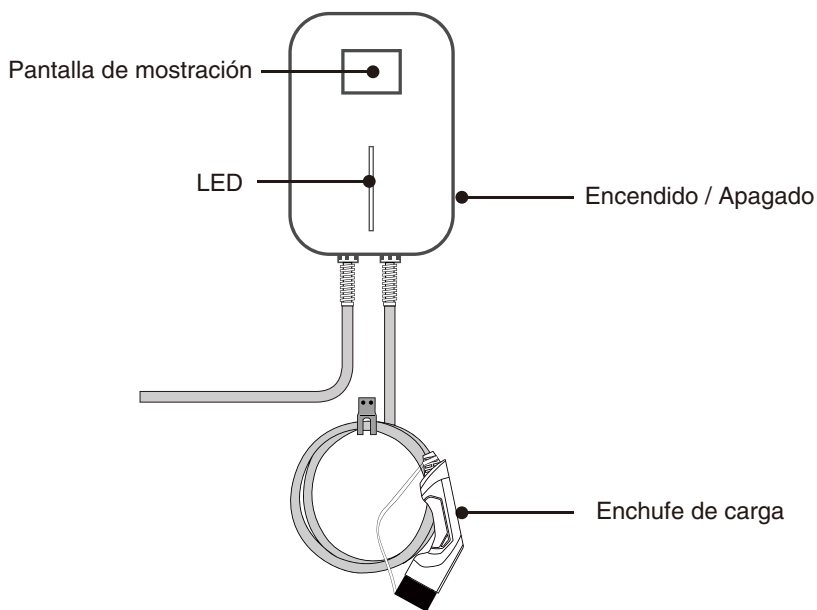

Estación de carga EV de nivel 2

Método de instalación: Pared / Pilar

Modo: C (con enchufe)

Certificado: TUV, CE

Clasificación IP: IP66

Voltaje nominal: 230VAC±10%

Corriente nominal: 16A

Potencia máximo: 11kw

Modo de fase: monofásico

Material de la caja: ABS + aleación de PC

Modo de inicio: botón (predeterminado)

Temperatura de funcionamiento: -40°C ~ 55°C

Protección contra cortocircuitos

Protección contra la sobretensión de salida

Protección de baja tensión de entrada

Protección contra sobrecalentamiento

Protección del suelo

Protección contra sobretensiones de entrada

Detección de estado de carga

Protección de seguridad: Funciones de advertencia y mostración

Instrucciones de uso

1

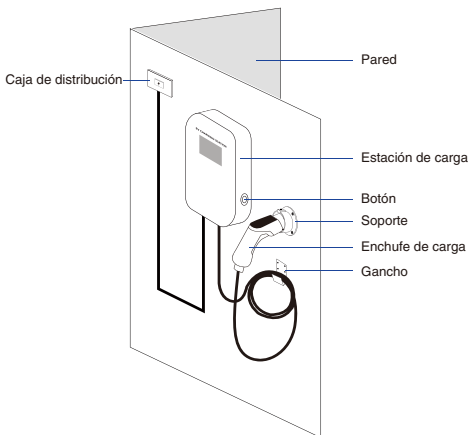

Asegúrese de que la caja de pared esté conectada a la alimentación

2

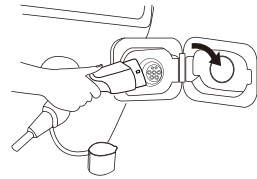

Conecte el cargador y la caja de pared con el cable de cargador

3

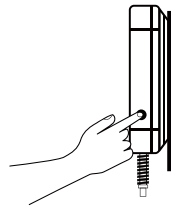

Presione el botón en el lado derecho de la caja de pared para encender / apagar la carga

◆ Cuelgue el cable en el gancho cuando no esté en uso

1

Papel de referencia para la instalación del tamaño del orificio del tornillo

Pared

Taladrar los orificios según el papel del referencia

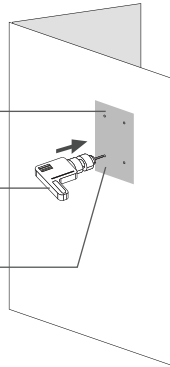

2

Martillar pernos plásticos de 30mm en los agujeros

Bajar el papel de referencia de la pared más tarde

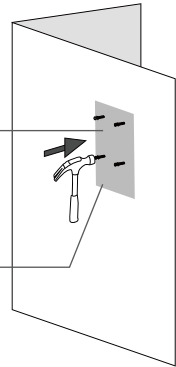

3

Fijar la placa con tornillos de 30mm en la pared

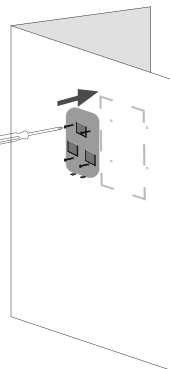

4

Incrustar la estación en la placa en la pared

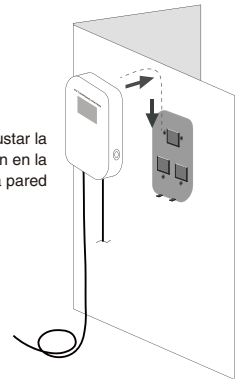

5

Esta es la imagen final, puede colocar el gancho y el soporte en cualquier lugar que necesite

El cable se puede colocar en el gancho y soporte

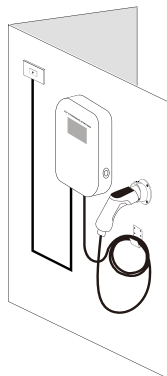

6

Retire la película protectora

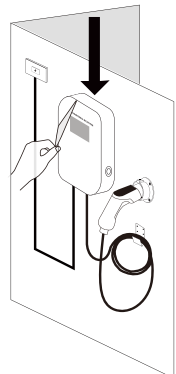

Accesorios de Modo A

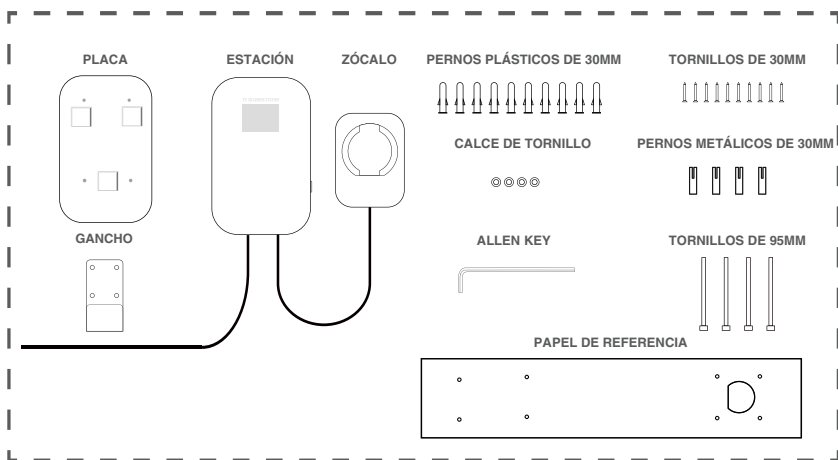

Resumen de la estación Modo A

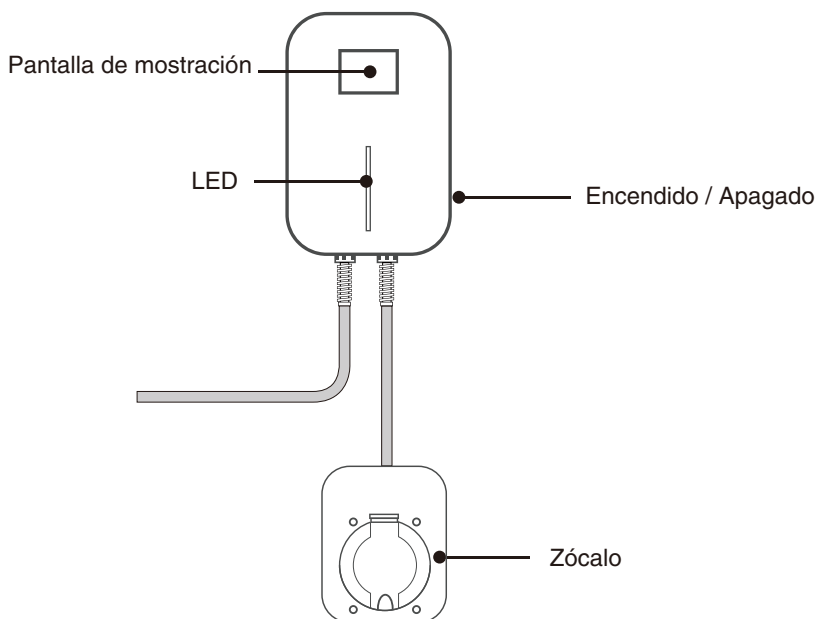

Estación de carga EV de nivel 2

Método de instalación: Pared / Pilar

Modo: A (con zócalo)

Certificado: TUV, CE

Clasificación IP: IP66

Voltaje nominal: 230VAC±10%

Corriente nominal: 16A

Potencia máximo: 11kw

Modo de fase: monofásico

Material de la caja: ABS + aleación de PC

Modo de inicio: botón (predeterminado)

Temperatura de funcionamiento: -40°C ~ 55°C

Protección contra cortocircuitos

Protección contra la sobretensión de salida

Protección de baja tensión de entrada

Protección contra sobrecalentamiento

Protección del suelo

Protección contra sobretensiones de entrada

Detección de estado de carga

Protección de seguridad: Funciones de advertencia y mostración

Instrucciones de uso

1

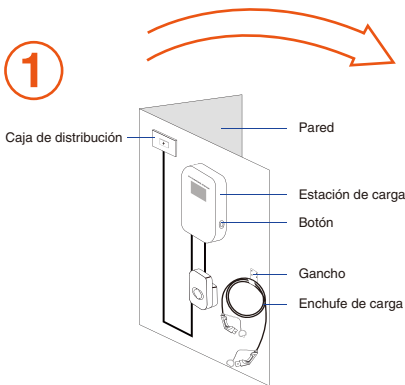

Asegúrese de que la caja de pared esté conectada a la alimentación

2

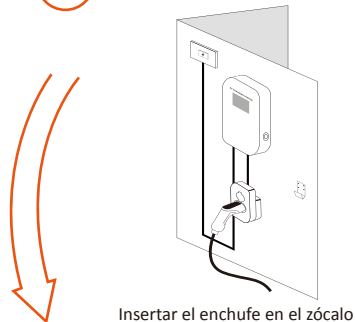

4

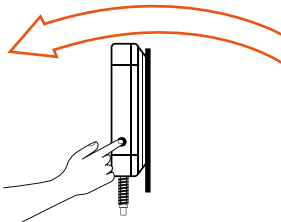

3

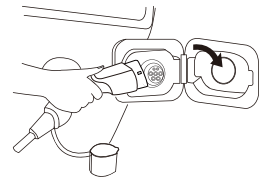

◆ Cuelgue el cable en el gancho cuando no esté en uso

1

Papel de referencia para la instalación del tamaño del orificio del tornillo

Pared

Taladrar los orificios según el papel del referencia

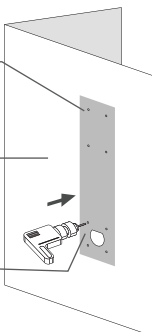

2

Martillar pernos plásticos de 30mm en los agujeros

Martillar pernos metálicos de 30mm en los agujeros

Bajar el papel de referencia de la pared más tarde

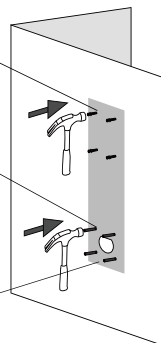

3

Fijar la placa con tornillos de 30mm en la pared

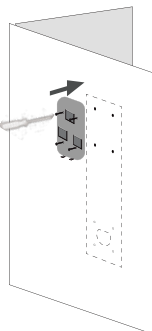

4

Incrustar la estación en la placa en la pared

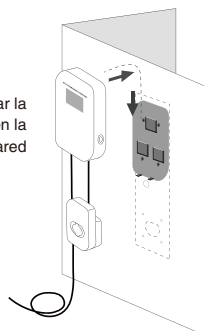

5

Sacar la placa del cuerpo del zócalo de carga

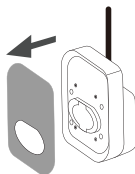

6

Fijar el zócalo en la pared con tornillos de 95mm con la allen key y volver a colocar la placa en el cuerpo del zócalo

TORNILLOS DE 95MM

CALCE DE TORNILLO

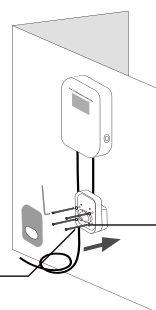

7

Conectar el cable de entrada y la fuente de alimentación correctamente

Esta es la imagen final, puede colocar el gancho en cualquier lugar que necesite

El cable se puede colocar en el gancho

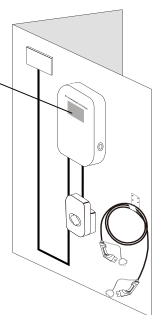

8

Retire la película protectora

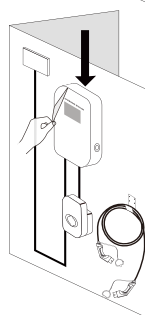



Pantalla de inicio
(El número de versión es solo para referencia)



Espera a que se inserte el enchufe



Esperar la identificación



Espera a que el coche esté listo



Durante el proceso de carga



Deja de cargar y espera a que se desconecte el enchufe



1. Poder en tiempo real
2. Datos de tres líneas de fuego
3. Tiempo de carga
4. Consumo de energía
5. Icono de carga
6. Temperatura del circuito



Possible fault warning

1. Parada de emergencia
2. Sobrecorriente
3. Sobretemperatura
4. Protección contra fugas
5. Corriente corta

	INACTIVO	CONECTADA	CARGA	TERMINADA	ERROR
Instrucción del estado del LED	Apagada	Continuo ligero	Rolling	Continuo ligero	Rojo Brillante

Nota: Cuando ocurren pequeños problemas, como una corriente corta, la caja de pared reiniciará automáticamente para reparar y seguirá cargando.

En caso de fallas graves, el sistema no puede recuperarse automáticamente, para recordarle al usuario esta falla, después de que el usuario desconecte el enchufe, el sistema realizará automáticamente una cuenta regresiva de 10 segundos para reiniciar

¡El incumplimiento de las instrucciones puede resultar peligroso!

- ▲ Verifique regularmente si el cargador portátil tiene daños evidentes, y puede haber peligro de descarga eléctrica al utilizar el cargador portátil dañado.
- ▲ Asegúrese de que todas las instalaciones de seguridad estén disponibles en todos momentos y realice pruebas regularmente para garantizar seguridad.
- ▲ En el caso de una falla a tierra, se debe suponer que el cable base transporta el voltaje y, después de confirmar que no hay energía de alto voltaje en el sistema, se inspeccione la estación de carga.
- ▲ Antes de encender el dispositivo, confirme que está correctamente conectado a tierra para evitar accidentes.
- ▲ La persona que instala y usa las estaciones de carga debe obedecer los principios y reglamentos mencionados para garantizar la seguridad personal y la seguridad del equipo.
- ▲ Asegúrese de que la vida útil y el funcionamiento del cable de carga sean estables, y el entorno para el uso del equipo debe mantenerse limpio, a temperatura y humedad constantes. El cable de carga no debe utilizarse en presencia de gases volátiles o atmósferas inflamables.
- ▲ No modifique, repare ni cambie ninguna pieza por usted mismo en cualquier caso.
- ▲ Todas las herramientas utilizadas que no requieren que las partes metálicas estén expuestas, deben estar aisladas para evitar que las partes metálicas expuestas toquen el marco de metal, provocando un cortocircuito.
- ▲ Antes de que el dispositivo esté encendido, asegúrese de confirmar que el voltaje de entrada, la frecuencia, los interruptores de circuito y otras condiciones del dispositivo hayan cumplido con las especificaciones.

Mantenimiento y Revisión

Las estaciones de carga de CA están sujetas a estrictas inspecciones de calidad. Desde el día de compra, cualquier problema de calidad causado por el uso correcto del equipo en un plazo de dos años puede reflejarse al minoristas para el servicio postventa.

La garantía no cubre ningún daño directo o mal funcionamiento causado por negligencia, manejo incorrecto, instalación, uso, reparación por parte de los usuarios o daños naturales.

Para garantizar la vida útil normal de la estación de carga y reducir el riesgo, el mantenimiento debe realizarse dentro del tiempo especificado. El mantenimiento del equipo debe ser completado por profesionales con herramientas de mantenimiento calificadas y seguras.

El producto ya está embalado en fábrica. Durante el transporte, deben evitarse golpes fuertes para evitar daños al embalaje exterior del producto. El producto debe colocarse a una temperatura ambiente de $-40^{\circ}\text{C} \sim 55^{\circ}\text{C}$ con una humedad relativa de no más del 95%. El aire no debe contener ácidos, álcalis u otros gases corrosivos y gases explosivos.

MANUFACTURER

Nanjing LuAo international tradeCo.,Ltd.

+86-025-8662-3210

No. 128, Aoti, Jianye District, Nanjing, Jiangsu, China

(Por favor, no contacte al fabricante si tiene pregunta relacionada con el servicio postventa)

Accessori della modalità C

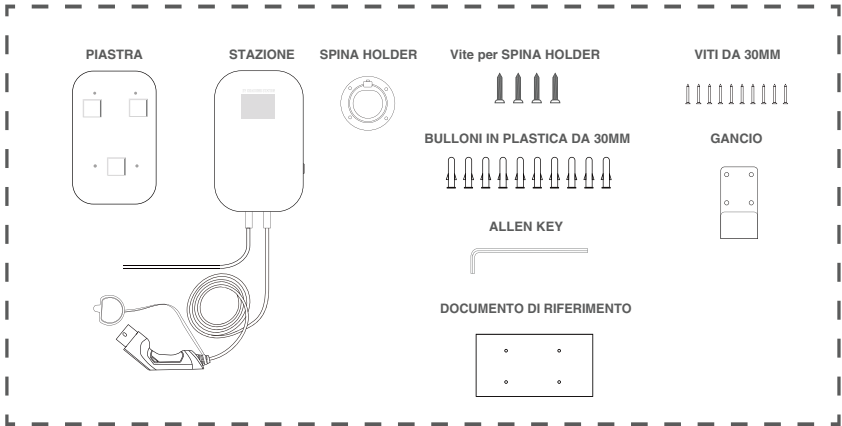

Panoramica della modalità C Station

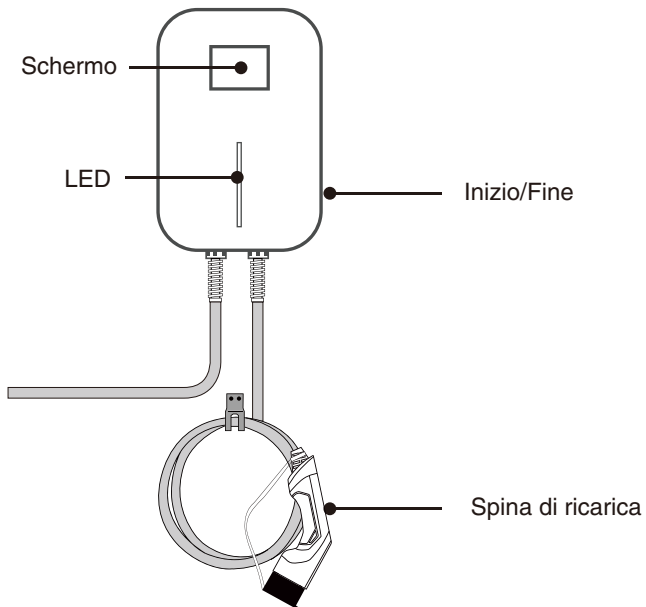

Stazione di ricarica EV di livello 2

Metodo di installazione: parete / palo

Modalità: C (con spina)

Certificato: TUV, CE

IP66

Gamma di tensione: 230 V \pm 10%

Corrente di funzionamento: 16 Amp

Potenza massima: 11 KW

Modalità di fase: monofase

Temperatura di lavoro: -40 °C ~ 55 °C

Materiale guscio: ABS+PC Lega

Modalità di avvio: pulsante (predefinito)

Protezione di sicurezza:

Funzioni di avvertimento e indicatore

Protezione da cortocircuito

Protezione da sovracorrente in uscita

Protezione da sottotensione in ingresso

Protezione da sovratemperatura

Protezione del terreno

Protezione da sovratensione in ingresso

Rilevamento dello stato di carica

Istruzioni per l'uso

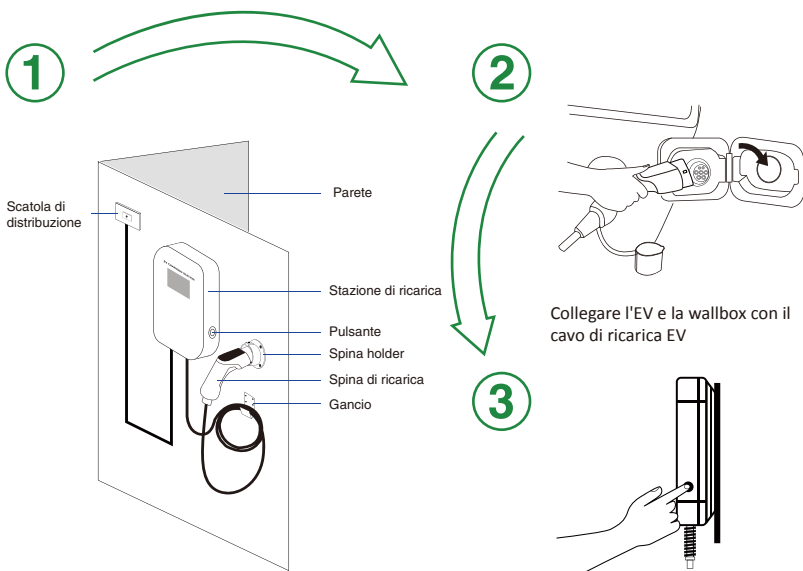

Assicurarsi che il wallbox sia collegato all'alimentazione

Premere il pulsante sul lato destro della wallbox per avviare / interrompere la ricarica

◆ Appendere il cavo sul gancio quando non è in uso

1

RIFERIMENTO CARTA
di installazione della
dimensione del
foro della vite

Parete

Praticare i fori secondo
la CARTA DI
RIFERIMENTO

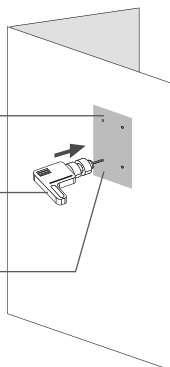

2

Martellare i
BULLONI IN PLASTICA
da 30mm nei fori

Prendi il
CARTA DI RIFERIMENTO
dal muro più tardi

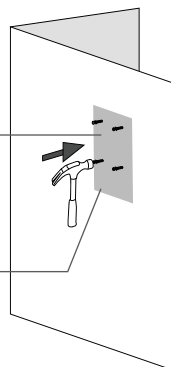

3

Fissare il PIASTRA
alla parete con una
VITI da 30 mm

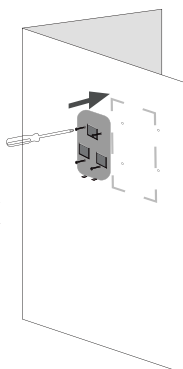

4

Incorpora
con STATION nel
PIASTRA sul muro

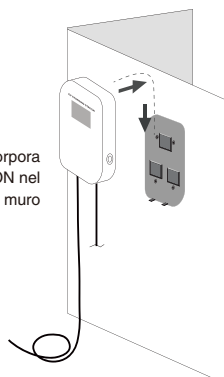

5

Questa è l'immagine
finale completa,
è possibile installare il
GANCIO e il SPINA HOLDER
ovunque si desideri

Il cavo può essere
appeso al GANCIO
e al SPINA HOLDER

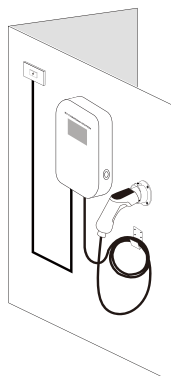

6

Accessori della modalità A

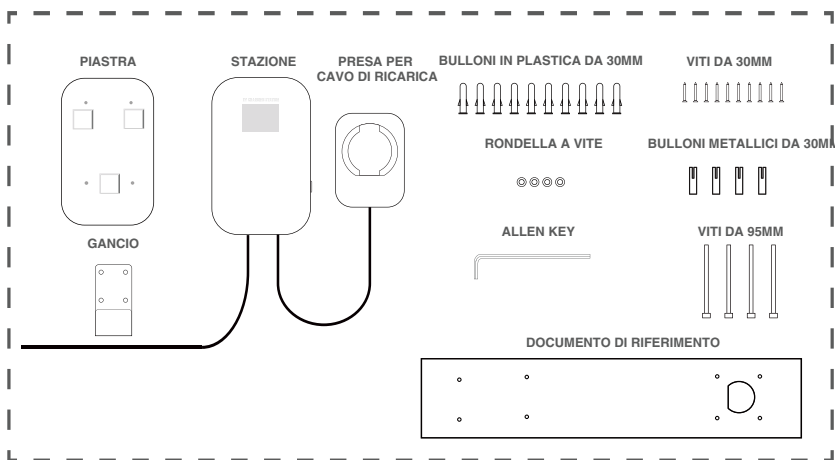

Panoramica della modalità A Station

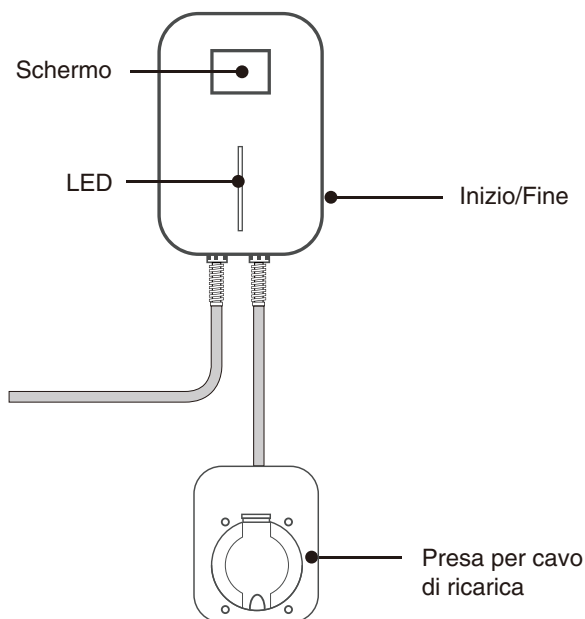

Stazione di ricarica EV di livello 2

Metodo di installazione: parete / palo
 Modalità: A (con Presa per cavo di ricarica)
 Certificato: TUV, CE
 IP66
 Gamma di tensione: 230 V \pm 10%
 Corrente di funzionamento: 16 Amp
 Potenza massima: 11KW
 Modalità di fase: monofase
 Temperatura di lavoro: -40 ° C ~ + 55 ° C
 Materiale guscio: ABS+PC Lega
 Modalità di avvio: pulsante (predefinito)

Protezione di sicurezza:
 Funzioni di avvertimento e indicatore
 Protezione da cortocircuito
 Protezione da sovracorrente in uscita
 Protezione da sottotensione in ingresso
 Protezione da sovratemperatura
 Protezione del terreno
 Protezione da sovratensione in ingresso
 Rilevamento dello stato di carica

Istruzioni per l'uso

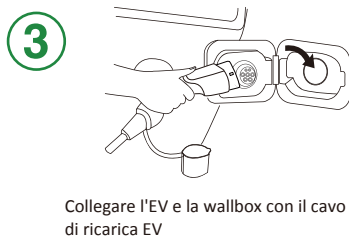
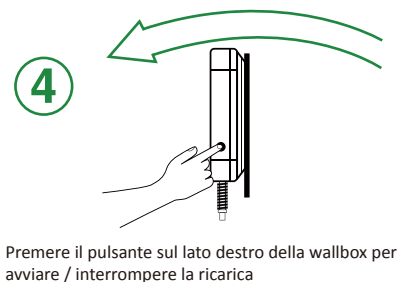
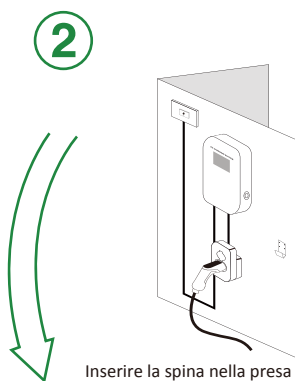
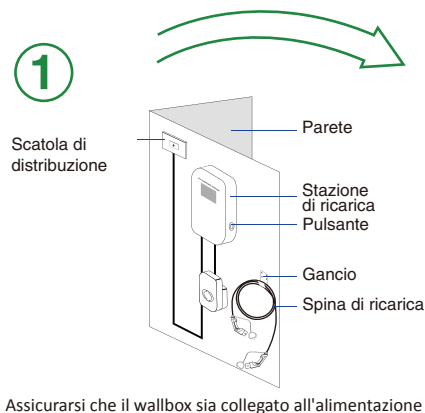

◆ Appendere il cavo sul gancio quando non è in uso

1

RIFERIMENTO CARTA di installazione della dimensione del foro della vite

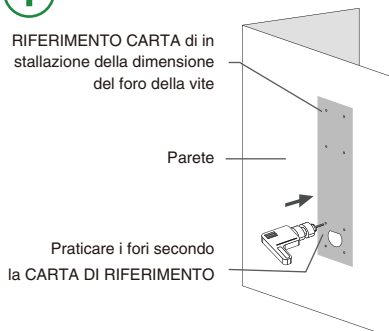

Praticare i fori secondo la CARTA DI RIFERIMENTO

2

Martellare i BULLONI IN PLASTICA da 30mm nei fori

Martellare i BULLONI METALLICI da 30mm nei fori

Prendi il CARTA DI RIFERIMENTO dal muro più tardi

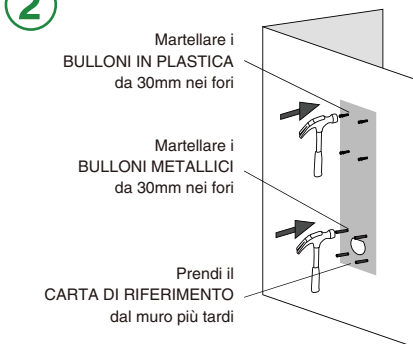

3

Fissare il PIASTRA alla parete con una VITI da 30 mm

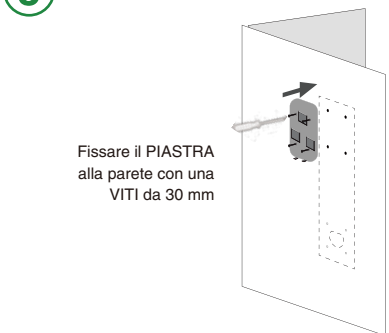

4

Incorpora con STATION nel PIASTRA sul muro

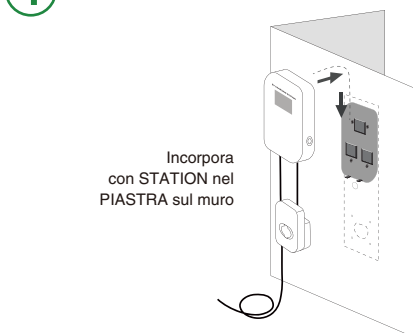

5

Estrarre la piastra dal corpo di ricarica SOCKET



6

Montare SOCKET alla parete con ALLEN KEY e VITI da 95mm, quindi installare di nuovo il pannello su SOCKET

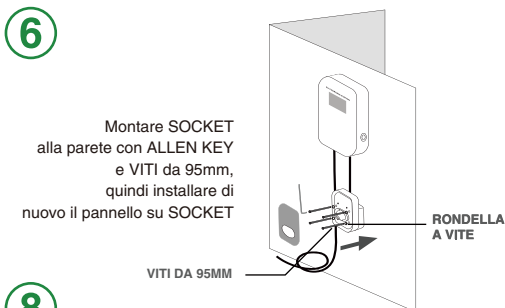

7

Collegare correttamente il cavo di ingresso e l'alimentazione

è possibile installare il GANCIO ovunque si desideri

Il cavo può essere appeso al GANCIO

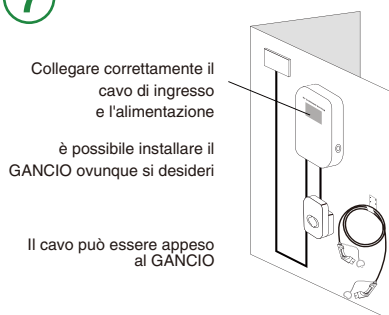

8



Schermata iniziale
(la versione è solo per riferimento)



Attendi l'inserimento
della spina



Attendi l'identificazione



Aspetta che la macchina
sia pronta



Durante il processo di ricarica



Interrompere la ricarica e
attendere estraendo la spina



1. Potenza in tempo reale
2. Tre dati del filo in tensione
3. Tempo di ricarica
4. Consumo di energia
5. Icona di ricarica
6. Temperatura del PCB

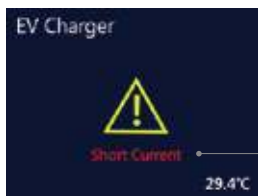

Possible
fault warning

1. Arresto di emergenza
2. Sovraccorrente
3. Temperatura eccessiva
4. Protezione dalle perdite
5. Corrente corta

	INATTIVA	COLLEGATA	CARICA	FINITA	ERRORE
Istruzione dello stato del LED	OFF	Continuo luce	Rotolamento	Continuo luce	Rosso lampeggiante

Nota: quando si verificano piccoli problemi come la corrente corta, la wallbox si riavvia automaticamente per riparare e continuare a caricare.

Per guasti gravi, il sistema non può recuperare automaticamente, per ricordare all'utente questo guasto, dopo che l'utente ha estratto la spina di ricarica, il sistema eseguirà automaticamente il conto alla rovescia di 10 secondi per riavviarsi

Avviso di sicurezza

La mancata osservanza delle istruzioni può risultare in pericolo!

▲ Controllare regolarmente se la stazione di ricarica ha danni visibili. Potrebbe esserci una scossa elettrica quando si utilizza la stazione di ricarica rotta.

▲ Accertarsi che tutte le funzioni di sicurezza siano sempre disponibili e sottoposte a test periodici per assicurarsi che funzionino normalmente.

▲ Se si verifica un guasto verso terra, si deve presumere che il cavo trasporta tensione. Si prega di confermare che non vi è alcuna alimentazione ad alta tensione nel sistema prima di ispezionare la stazione di ricarica.

▲ Le persone che installano e utilizzano le stazioni di ricarica devono rispettare i principi e le norme citate per garantire la sicurezza personale e la sicurezza delle attrezzature.

▲ Prima di accendere il dispositivo, verificare che il dispositivo sia correttamente collegato a terra per evitare incidenti non necessari.

▲ Tutte le parti metalliche esposte non necessarie devono essere isolate per evitare che tocchino il telaio metallico per evitare cortocircuiti.

▲ Non modificare, aggiornare o modificare alcuna parte da soli in nessuna circostanza.

▲ Per garantire la durata e il funzionamento stabile della stazione di ricarica, l'ambiente operativo deve essere mantenuto il più pulito possibile con una temperatura e un'umidità relativamente stabili. La stazione di ricarica non deve essere utilizzata in ambienti infiammabili o in ambienti con gas volatili.

▲ Accertarsi che la tensione di ingresso, la frequenza, gli interruttori di circuito e le altre condizioni del dispositivo soddisfino le specifiche prima dell'accensione del dispositivo.

Manutenzione e revisione

Le stazioni di ricarica AC sono soggette a severi controlli di qualità. Modalità 2 La ricarica è soggetta a severi controlli di qualità. Dal giorno dell'acquisto, qualsiasi problema di qualità del prodotto può essere riflesso al rivenditore entro due anni.

Eventuali danni diretti o malfunzionamenti causati da negligenza, uso errato, installazione, utilizzo, riparazione da parte dell'utente o danni naturali non sono coperti dalla garanzia.

Per garantire la normale durata della stazione di ricarica e ridurre i rischi, la manutenzione deve essere eseguita entro il tempo specificato. La manutenzione delle attrezzature deve essere completata da professionisti con strumenti di manutenzione qualificati e sicuri.

Il prodotto è già imballato in fabbrica. Durante il trasporto, evitare forti urti e urti per evitare danni all'imballo esterno del prodotto.

Il prodotto deve essere posizionato a una temperatura ambiente di $-40\text{ }^{\circ}\text{C} \sim 55\text{ }^{\circ}\text{C}$ con un'umidità relativa non superiore al 95%. L'aria non deve contenere acidi, alcali di altri gas corrosivi e gas esplosivi.

MANUFACTURER

Nanjing LuAo international tradeCo.,Ltd.

+86-025-8662-3210

No.128,Aoti,Jianye District, Nanjing, Jiangsu, China

(Si prega di non contattare il telefono del produttore per domande post-vendita)



User Guide

Wallbox



ENGLISH

GERMAN

FRENCH

SPANISH

ITALIAN

Three Phase EV Charger



MORECEVSE

**For more sales promotions,
please follow MOREC official
Facebook account: @MORECEVSE**

✉ Morec Server Email : morecinfo@163.com
☎ Morec Customer Server Tel: +86-176-2601-9620
f Facebook : @MORECEVSE