

**FIT BIKE**

**RACE MAGNETIC PRO**



***FIT BIKE***

I N D O O R C Y C L E S

Index

1. Safety instructions / Maintenance .....	3
2. Parts list.....	5
3. Hardware and tools list .....	6
4. Overview drawing .....	7
5. Assembly.....	8





## 2. Parts list

Nr	Beschrijving	Aantal	Nr	Beschrijving	Aantal
1	Hoofd frame	1	42	Gecomprimeerde veer	1
2	Voetsteun voor	1	43	Crank plug	2
3	Voetsteun achter	1	44	Moer M12x1.5x10.4	4
4	Stuurbuis	1	45	Bout M8x15	3
5	Zadelpen	1	46	Ring 10x29x2T	2
6	Stuur	1	47	Schroef M5x12	5
7	Zadelopzet	1	48	Bidonhouder	1
8	Plastic houders	2	49	Schroef M5x10	2
9	Zadel	1	50	Schroef M3x20	1
10	Vliegwiël	1	51	Stalen buis 12x17x9T	1
11	V-snaar wiel met as	1	52	Schroef M4.5x15	2
12	V-snaar	1	53	Schroef M4.2x10	13
13	Kettingkast (R)	1	54	Bout M6x35	1
14	Kettingkast (L)	1	55	Klein wiel ophanging	1
15	Kettingkast klein (R)	1	56	Moer M10x9T	2
16	Kettingkast klein (L)	1	57	Stalen buis 25.1x32x10T	1
17	Afdekkapje	1	58	Kogellager 6005-2RS	2
18R	Crank (R)	1	59	C-ring 20	2
18L	Crank (L)	1	60	C-ring 25	1
19	Plastic dop voor crank	2	61	Statisch wiel	1
20R	Trapper (R)	1	62	Gebogen ring 27x34	1
20L	Trapper (L)	1	63	Plastic ring	2
21	L-knop A	1	64	Draadplug	1
22	L-knop B	1	65	Stalen buis 10.2x15x6T	1
23	Knop M10x28	1	66	As	1
24	Borgmoer M10	1	67	Gebogen ring 21x27	1
25	Ring 19.5x38x2T	1	68	Ring 20.5x25x0.5T	1
26R	Magneet cover R	1	69	Bout M10x32	1
26L	Magneet cover L	1	70	Ring 12x17x1.0T	2
27	Steun	1	71	Plastic lager	4
28	Magneet	1	72	Plastic buis 7.9x12.7	2
29	Weerstandsstang	1	73	Plaatje	1
30	Cover	1	74	Voetje M10x25	4
31	C-vorm	2	75	Kap 76	4
32	Verchroomd plaatje	1	76	Transport wiel	2
33	Borgmoer M6	2	77	Weerstandsknop	1
34	Borgmoer M8	2	78	Bout M5x15	2
35	Moer M10	4	79	Bout M5x10	2
36	Bout M10x55	4	80	Schroef M4.5x25	5
37	Ring 10x19x1.5T	6	81	Plastic kap	1
38	Moer M10x6T	4	82	Ring 12x24x1.5T	2
39	Bout M8x38	2	83	Ring 5	2
40	Veer 2.6	1	84	Plastic buis	1
41	Stelstang	1	85	Ring 10x16x1.5T	1

### 3. Hardware and tools list

---

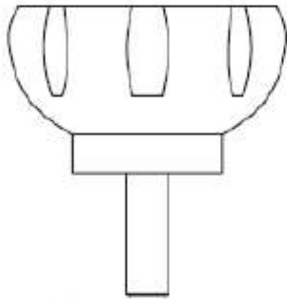

NO.23 Knop  
M10x28 1x

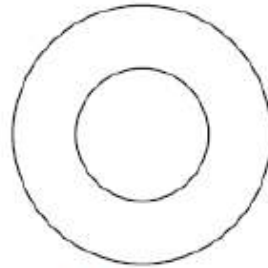

NO.25 Ring  
19.5x38x2T 1x

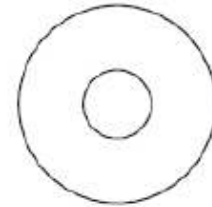

NO.46 Ring  
10x29x2T 2x



NO.35 Moer  
M10 4x

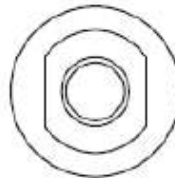

NO.24 Moer  
M10 1x

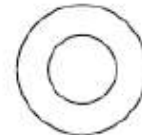

NO.37 Ring  
10x19x1.5T 4x

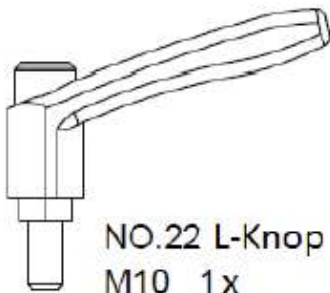

NO.22 L-Knop  
M10 1x

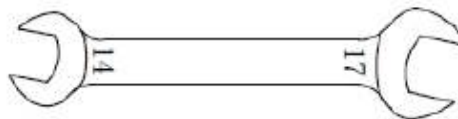

Steeksleutel  
14,17mm 1x



NO.36 Bout  
M10x55 4x

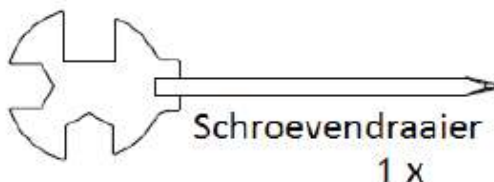

Schroevendraaier  
1x



Steeksleutel 13,15mm 1x

4. Overview drawing

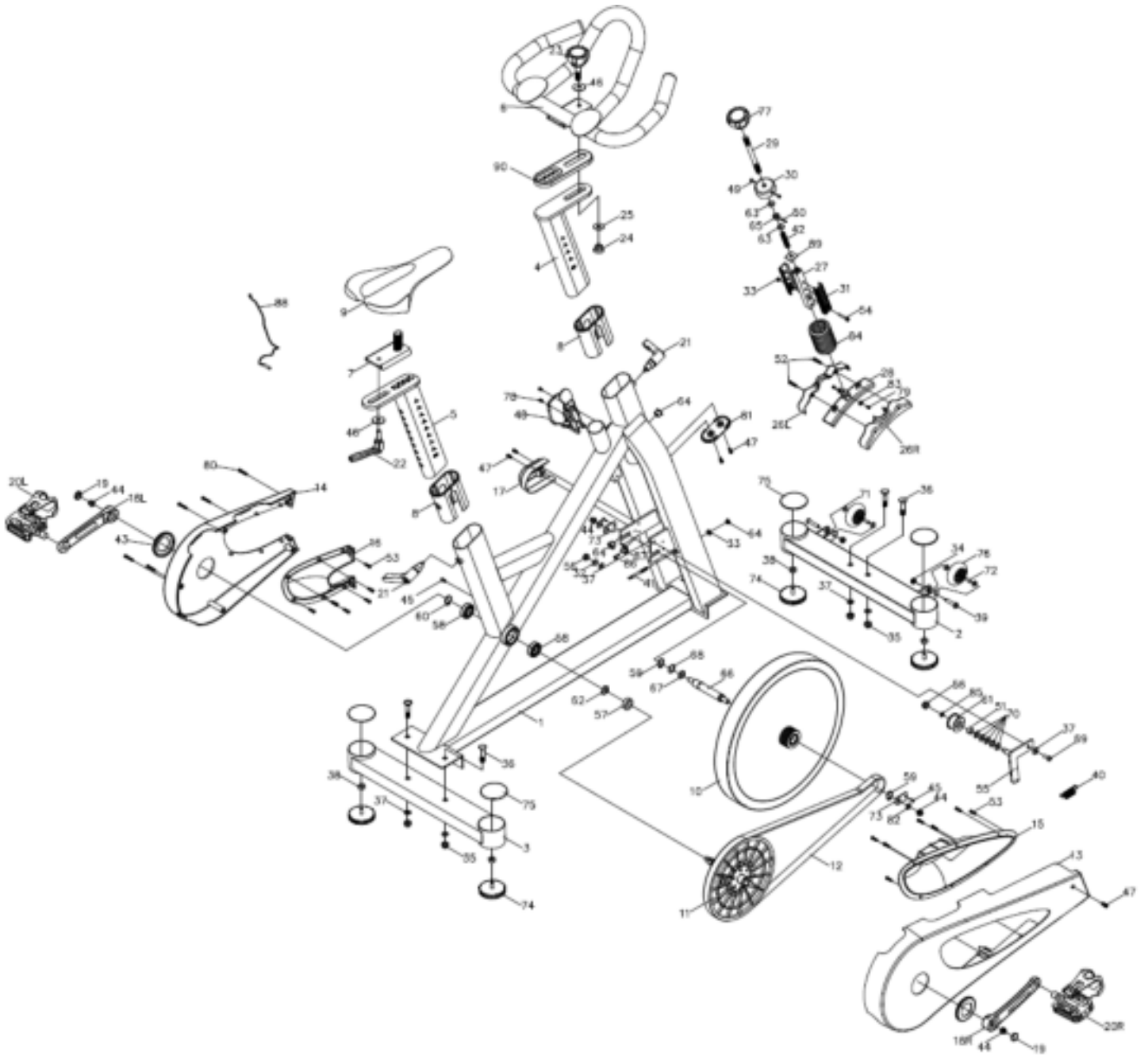

## 5. Assembly

1)

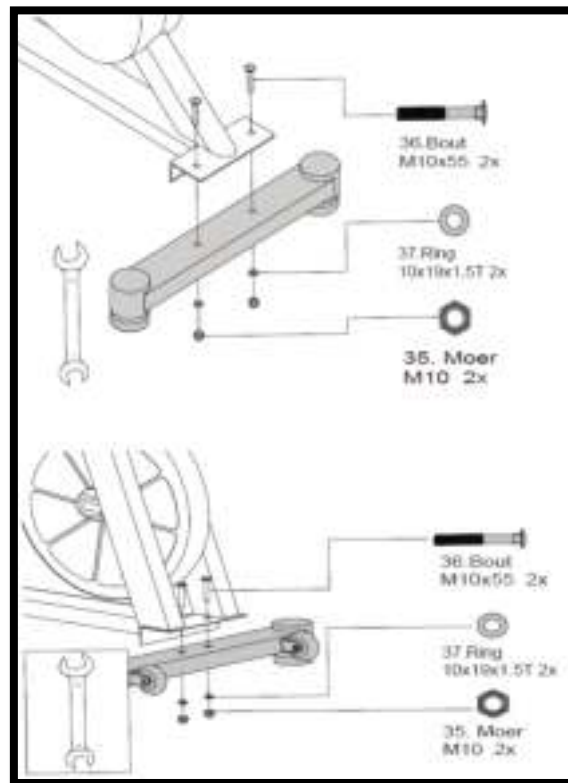

2)

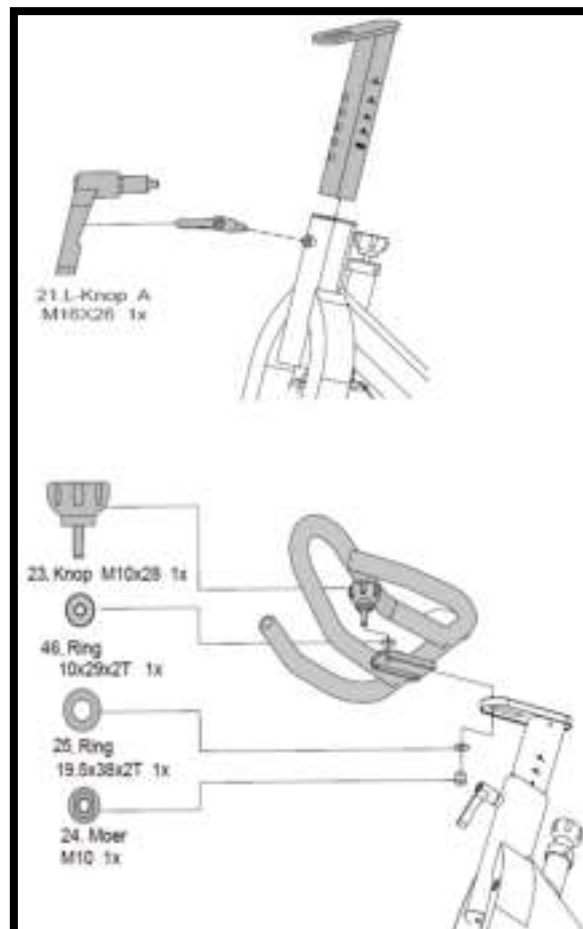



3)

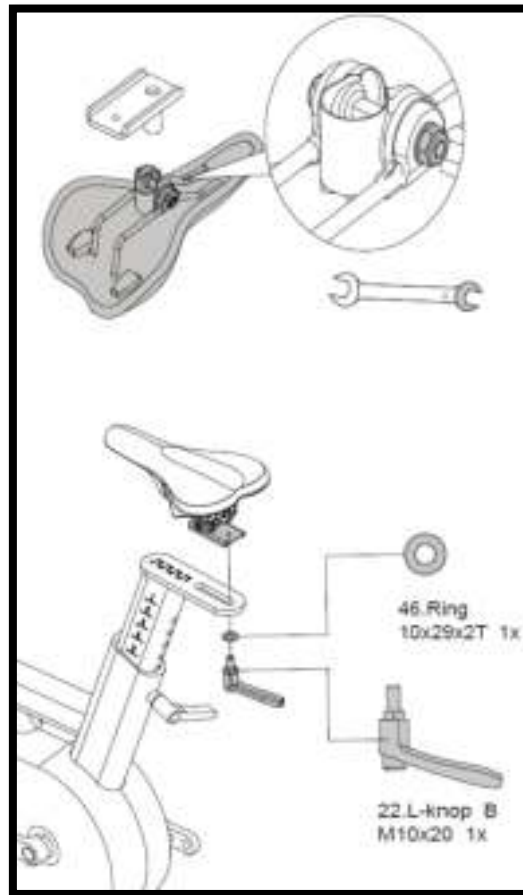

4)

