



### Application

- Can be used to transfer clean water or other liquids similar to water in physical and chemical properties
- Suitable for lifting water from the well, sprinkling irrigation in garden, pressure boosting of running water, and supporting equipment etc.

### Pump

- Cast iron pump body and support under special anti-rust treatment
- Stainless steel impeller
- AISI 304 shaft
- Max. liquid temperature: +40°C
- Max. suction: +9 m

### Motor

- C&U bearing
- Motor with copper winding
- Built-in thermal protector for single phase motor
- Insulation class: F
- Protection class: IPX4
- Max. ambient temperature: +40°C

### Identification Codes

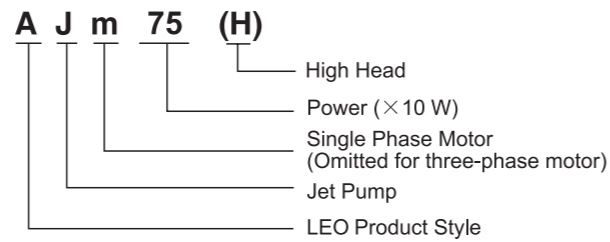

### Technical Data

MODEL	POWER		Q (m³/h)																
	kW	HP	0	0.3	0.6	0.9	1.2	1.5	1.8	2.1	2.4	2.8	3.0	3.3	3.6	3.9			
AJm30	0.3	0.4	35	30	26	22.5	20	18	16	14	-	-	-	-	-	-			
AJm45	0.45	0.6	41	36	32	28	25	22	20	18	-	-	-	-	-	-			
AJm60	0.6	0.8	45	41	37	33.5	31	28.5	26	24	22.5	21	-	-	-	-			
AJm75	0.75	1.0	40	38	36	34.5	33	31.5	30	29	28	27	26	25	24	23			
AJm75H	0.75	1.0	51	47	43	40	37	34.5	32	30	27.5	25	-	-	-	-			
AJm90	0.9	1.2	48	46	44	42.5	41	39.5	38	36	35	34	33	32	31	30			
AJm90H	0.9	1.2	62	57	53	49	46	43	40	37	35	33	-	-	-	-			

### Hydraulic Performance Curves

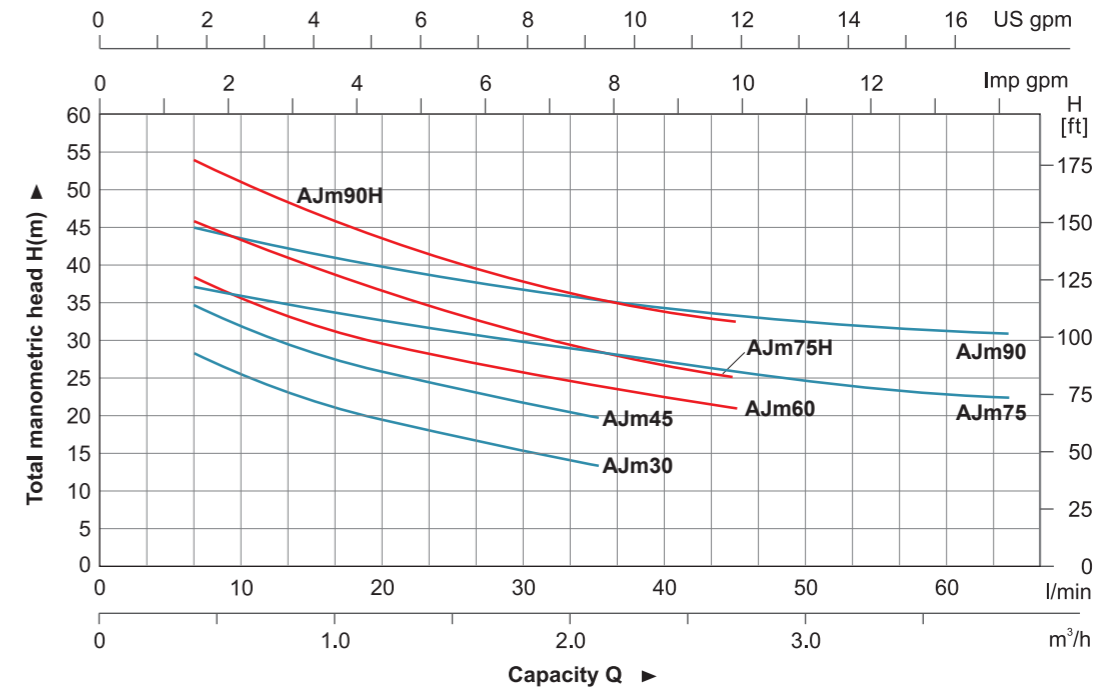

### Materials Table

No.	Part	Material
1	Pump body	HT 200
2	Venturi tube	PPO
3	Diffuser	PPO
4	Impeller	AISI 304
5	Mechanical seal	Carbon/Ceramic
6	O-ring	NBR
7	Support cover	HT 200
8	Support	ZL 102
9	Bearing	
10	Rotor	
11	Fan cover	PP
12	Fan	PP
13	Rear cover	ZL 102
14	Capacitor	
15	Terminal box	ABS
16	Terminal board	
17	Stator	

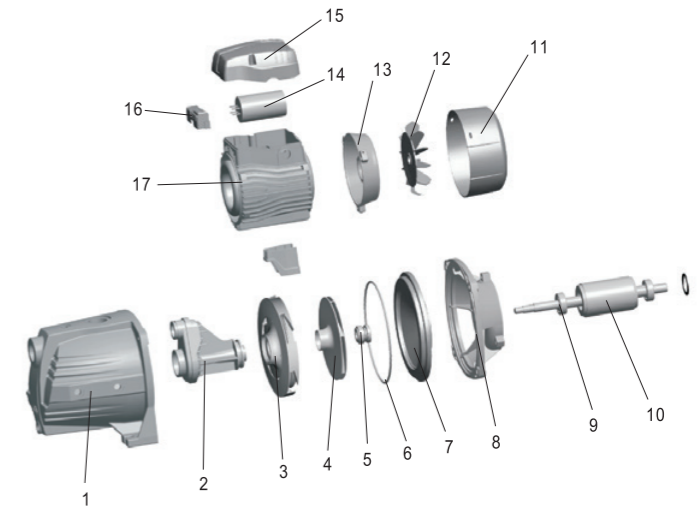

### Package Information

Model	GW (Kgs)	L (mm)	W (mm)	H (mm)	Quantity (PCS/20' TEU)
AJm30	9.2	390	185	215	1740
AJm45	10.15	390	185	215	1740
AJm60	14.35	455	215	245	1170
AJm75	15.5	455	215	245	1170
AJm75H	15.5	450	215	245	1170
AJm90	16.45	455	215	245	1170
AJm90H	16.45	450	215	245	1170



### Dimension

Model	DN1	DN2	A (mm)	B (mm)	C (mm)	D (mm)	E (mm)	F (mm)	G (mm)
AJm30	1"	1"	358	160	105	180	89.5	90	10
AJm45	1"	1"	358	160	105	180	89.5	90	10
AJm60	1"	1"	418	190	150	212	113	100	10
AJm75	1"	1"	418	190	150	212	113	100	10
AJm75H	1"	1"	418	190	150	212	113	100	10
AJm90	1"	1"	418	190	150	212	113	100	10
AJm90H	1"	1"	418	190	150	212	113	100	10

