





# ASSEMBLY INSTRUCTIONS

Read this instruction carefully. See hardware and furniture part list for guidance. Be sure all part is complete, before you assemble. Place all wooden furniture part on a clean and flat soft surface to prevent from being scratched. Follow the figure to start assembling.

## CAUTIONS :

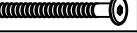
1. Do not FULLY-TIGHTEN the nut or nut bolt until all nut or bolt is ready assembled.
2. Do not OVER-TIGHTEN the nut or nut bolt to avoid causing damages to the thread.
3. Keep all hardware part out of reach of children.

PART LIST		
ITEM	DESCRIPTION	QTY
A	CUSHION SEAT	1 PC
B	LEG ( L & R)	2 PCS
C	APRON	2 PCS

HARDWARE LIST		
ITEM	DESCRIPTION	QTY
1	JCBC SCREW M6 x 50MM 	4 PCS
2	JCBC SCREW M6 x 60MM 	4 PCS
3	SPRING WASHER 1/4" 	8 PCS
4	M4 ALLEN KEY (BALL SHAPE) LONG 	1 PC
5	WOOD DOWEL DIA 8 x 35MM 	8 PCS
6	AJUSTABLE SCREW C89 	4 PCS

## STEP 1 :

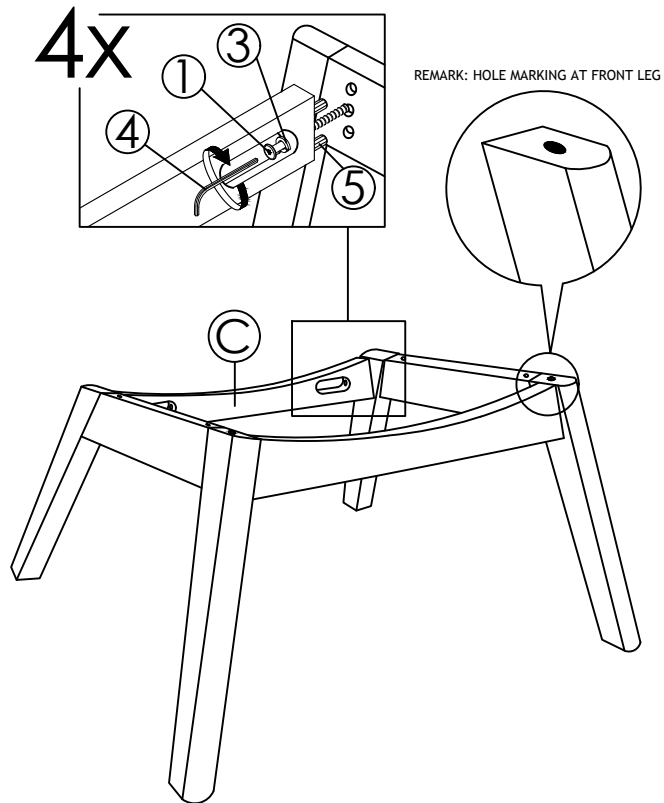

## STEP 2 :

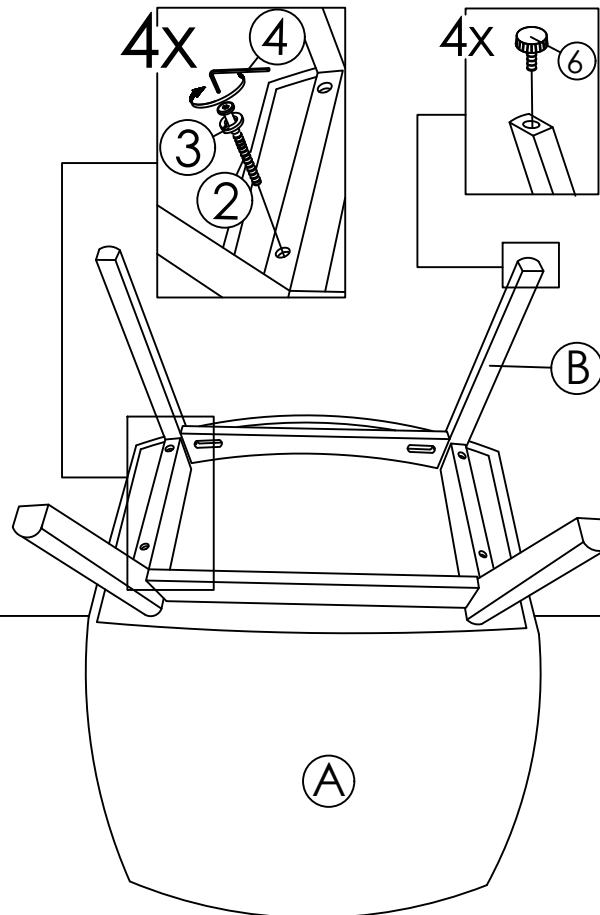

## STEP 3 :

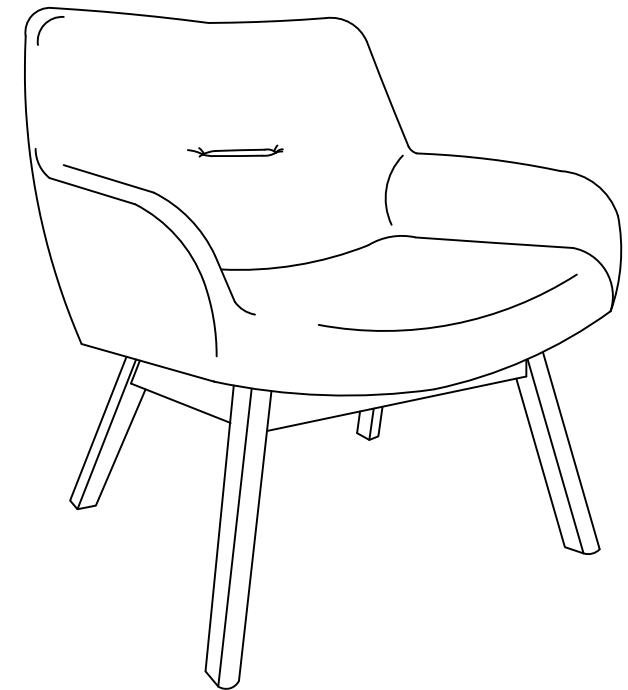

COMPLETED CHAIR ASSEMBLY