

MiZZO
Design
High quality kitchen taps & sinks

Arlori 10090



MiZZO
Design
High quality kitchen taps & sinks

Directory

EN: Installation manual	1-4
NL: Installatie handleiding	5-8
DE: Installationsanleitung	9-13
ES: Manual de instalación	14-18
FR: Manuel d'installation	19-23
IT: Manuale di installazione	24-28

1. Technical information

Outlet pipe rotation	360 degrees
Spray head pull out distance	Up to 0.5 meter
Hot & cold water supply pressure	Min. 0.05 MPa (flowing pressure), Max 0.75 MPa (static pressure)
Recommended water temperature	60±5°C - 90°C note: do not use steam as hot water supply
Required tap hole	35 mm

2. Required tools for installation



Adjustable Wrench



Hands



Allen Key



Multifunctional pipe wrench

3. Included items



4.Parts Checklist

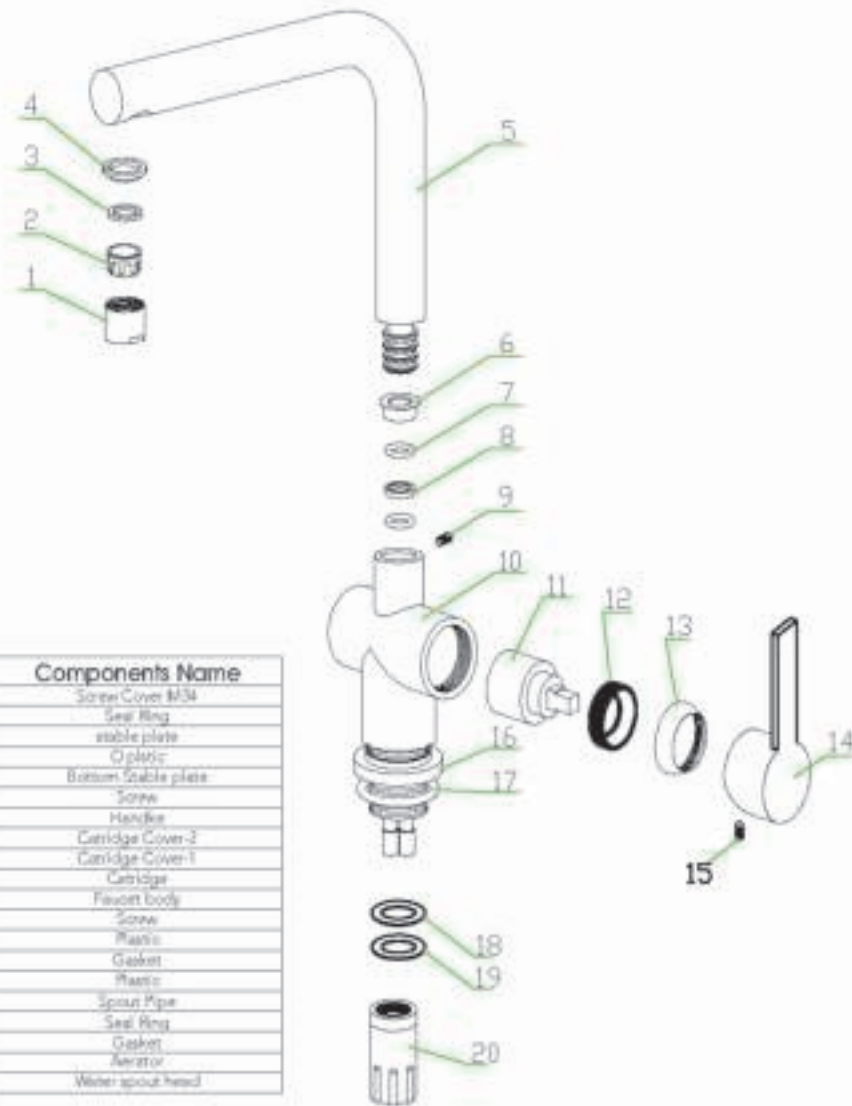

5.Dimension Drawing

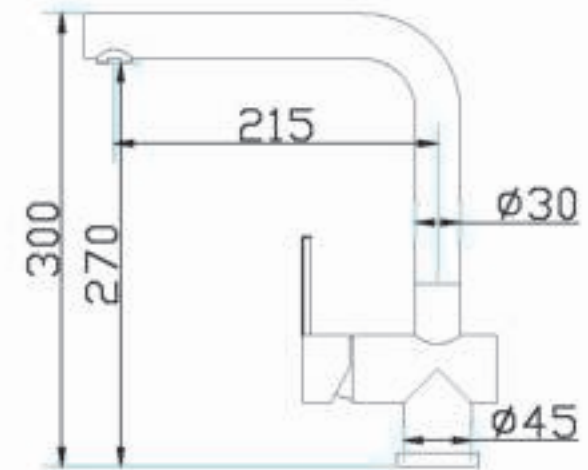

6.Installation Method



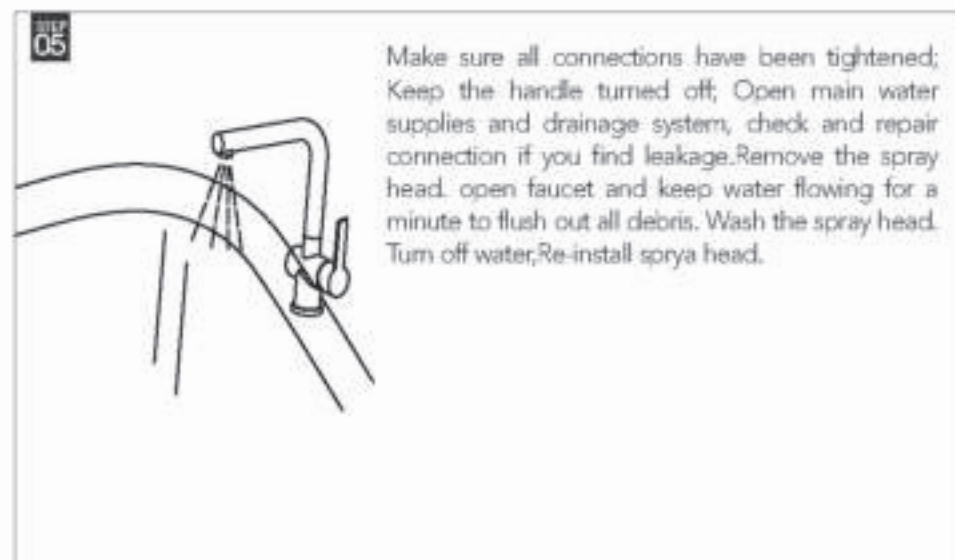
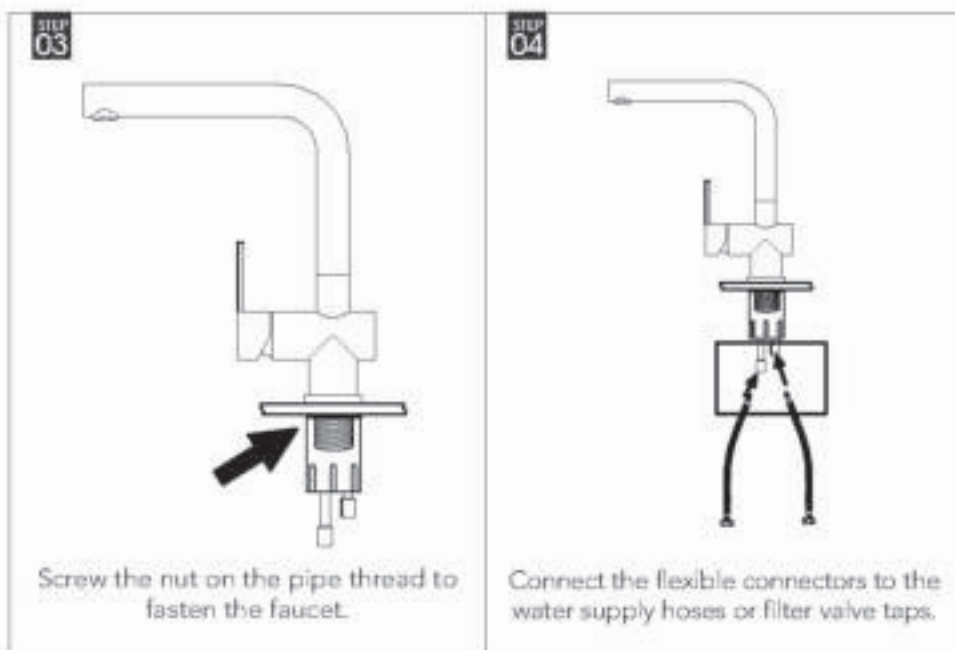
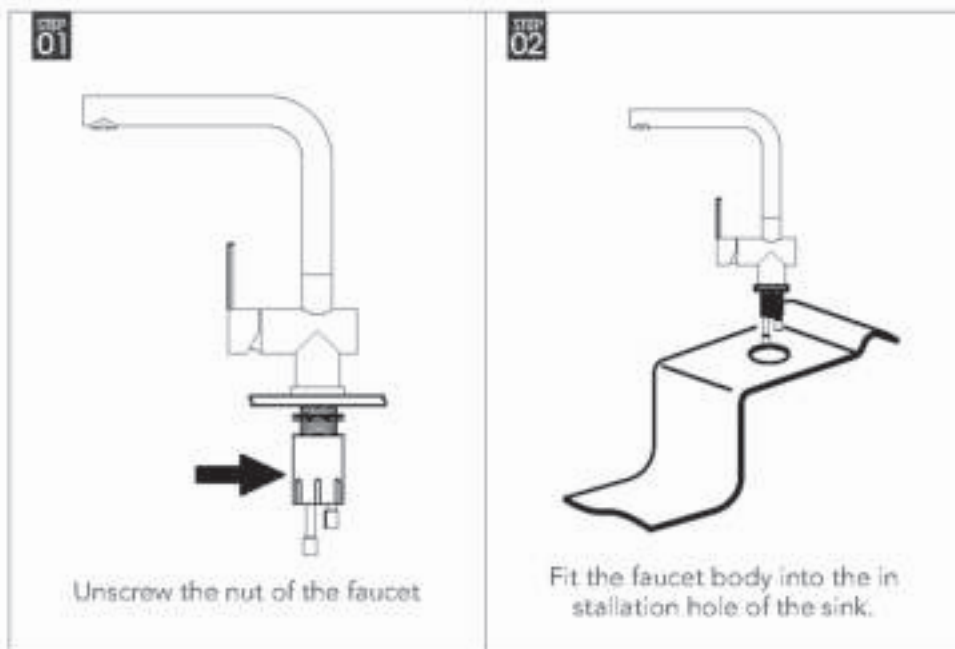

8. Care and maintenance

When installing the tap to new water supply hoses, we recommend that they are rinsed before the installation of the tap

In the process of using, care should be taken when cleaning this product. Use clean and dry soft cloth with mild soap to clean the product, do not use abrasive cleaners, chemicals or solvents (ammonia water, spirits of salt, harsh cleaner or cleaning powder) as they can result in surface damage.

When not using the faucet for a long time, please turn off water supplies valve.

9. Warranty

Since 2009 Dutch company Mizzo designs and develops design kitchen products like taps and kitchen sinks. We now offer a complete program of at least 100 design products. They all meet the strict rules that Mizzo requires of its own products, Mizzo therefore provides a 5 year warranty on its kitchen taps and a lifetime warranty on all kitchen sinks.

1. technische informatie

Draaibare uitloop	360 graden
Lengte uittrekbare slang	0.5 meter
Waterdruk warm en koud	Min. 0.05 MPa Max 0.75 MPa
Aanbevolen temperatuur	60±5°C - 90°C
Benodigd kraangat	35 mm

2. Benodigd gereedschap



Moersleutel



Handen



Inbussleutel



Waterpomp tang

3. De levering omvat de volgende producten

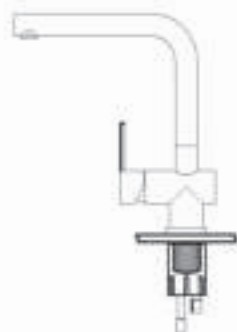

4. Onderdelen

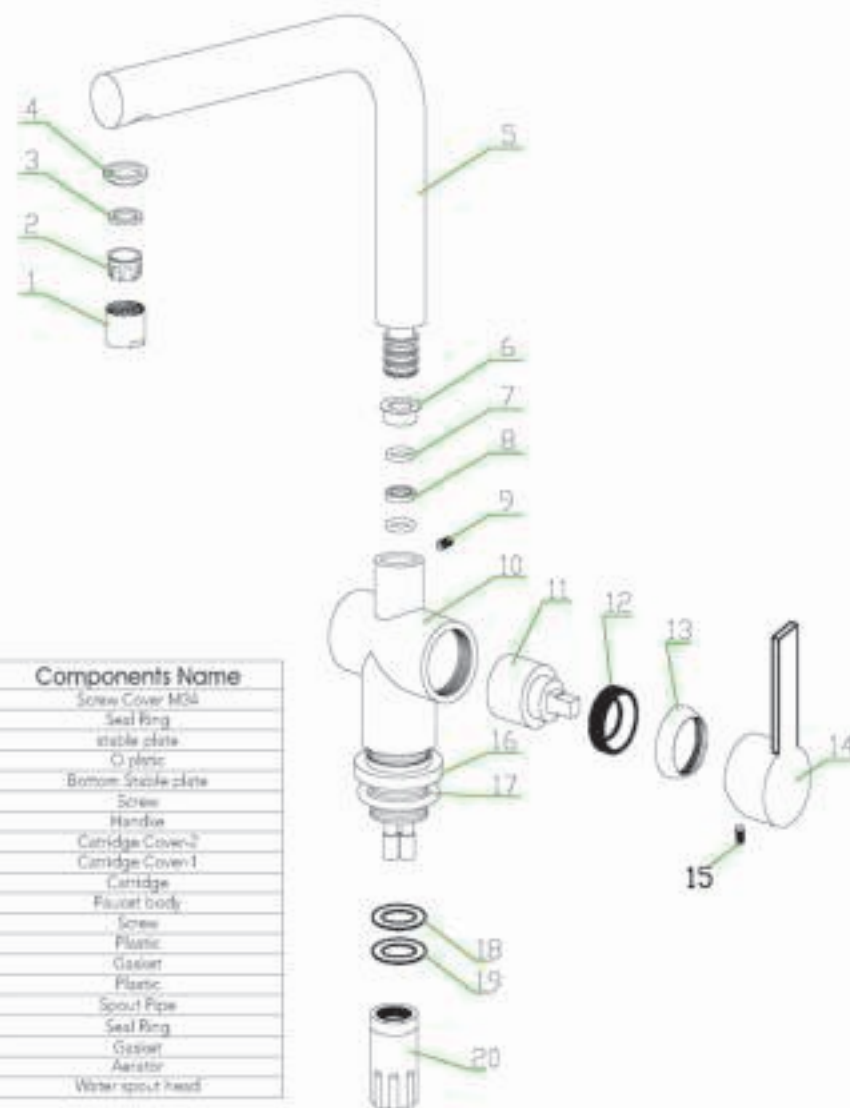

No.	Components Name
20	Screw Cover M04
19	Seal Ring
18	stable plate
17	O ring
16	Bottom stable plate
15	Screw
14	Handle
13	Cartridge Cover 2
12	Cartridge Cover 1
11	Cartridge
10	Faucet body
9	Screw
8	Plastic
7	Gasket
6	Plastic
5	Spout Pipe
4	Seal Ring
3	Gasket
2	Aerator
1	Water spout head

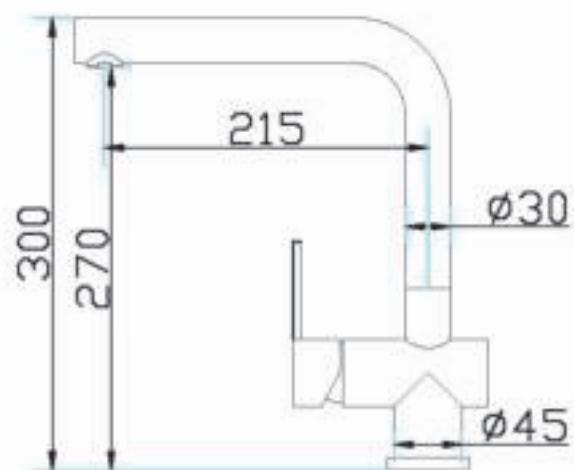

6. Installatie

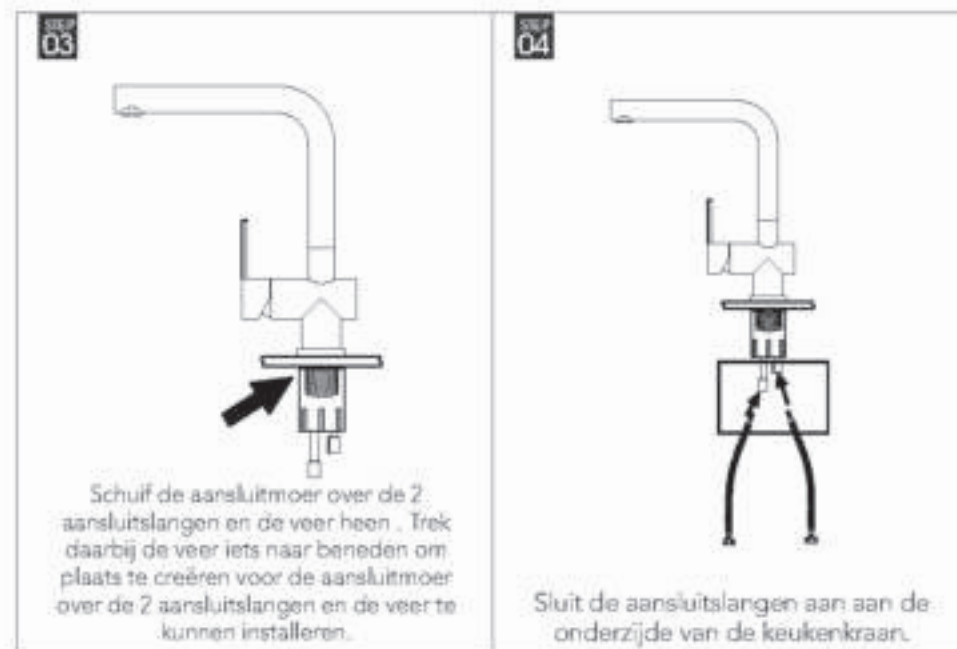
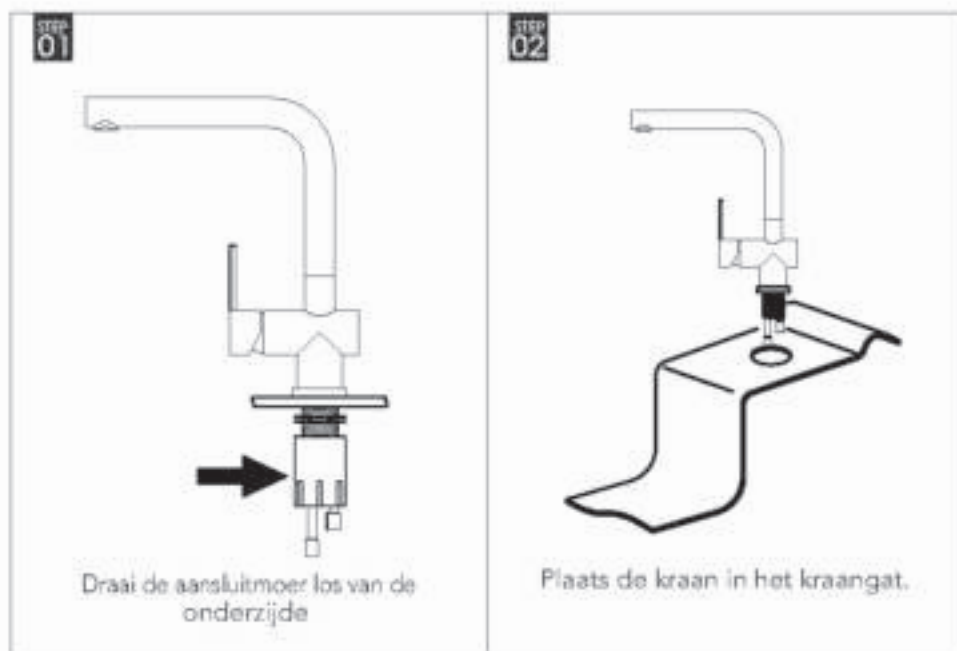

8. onderhoud en gebruik

Als u de kraan op nieuwe watertoevoerslangen installeert, raden we aan deze te spoelen vóór de installatie van de keukenkraan.

Tijdens het gebruik moet u voorzichtig zijn bij het reinigen van dit product. Gebruik een schone en droge zachte doek met milde zeep om het product te reinigen, gebruik geen schuurmiddelen, chemicaliën of oplosmiddelen (ammoniakwater, alcohol, zoutreiniger of reinigingspoeder). Deze kunnen resulteren in oppervlaktebeschadiging. Draai de watertoevoer kraan dicht als u de kraan lange tijd niet gebruikt.

9. Garantie

Sinds 2009 ontwerpt en ontwikkelt het Nederlandse bedrijf Mizzo designkeukenproducten zoals kranen en spoelbakken. Alle producten voldoen aan de strikte regels die Mizzo van zijn eigen producten verlangt. Mizzo biedt daarom

5 jaar garantie op de keukenkranen en levenslange garantie op alle spoelbakken.

1. Technische Information

Rotation Auslauf	360 Grad
Abstand herausziehbare Brause	Bis zu 0.5 Meter
Druck der Warm- und Kaltwasserversorgung	Min. 0.05 MPa (Fließend), Max 0.75 MPa (Statisch)
Empfohlene Wassertemperatur	60+5°C - 90°C Hinweis: Verwenden Sie keinen Dampf als Warmwasserversorgung
Erforderliches Hahnloch	35 mm

2. Erforderliche Werkzeuge für die Installation



Schraubenschlüssel



Handschuhe



Inbüsschlüssel



Rohrzange

3. Lieferumfang

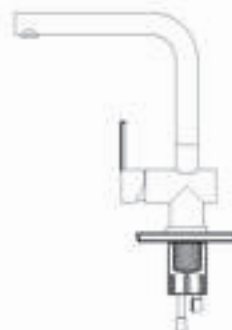

4. Armatur Einzelteile

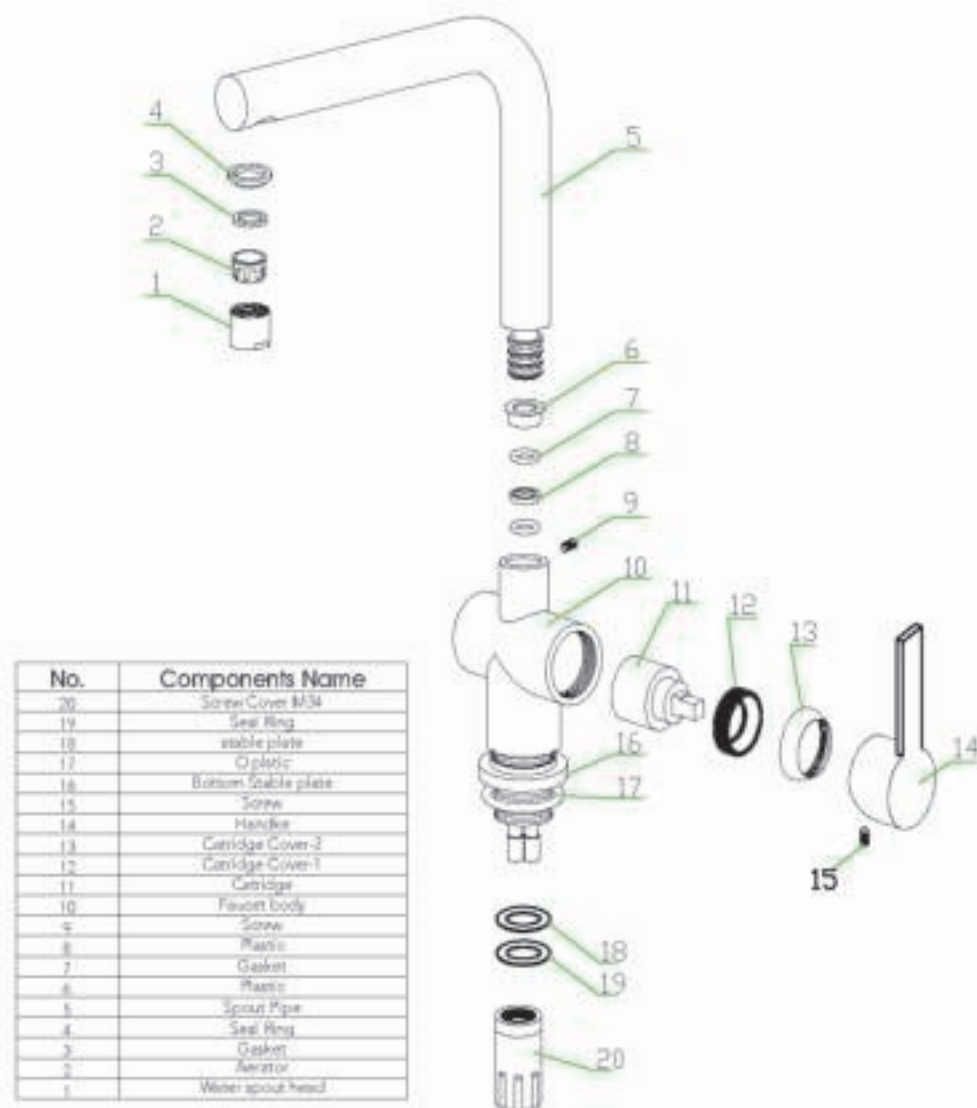

5. Größentabelle

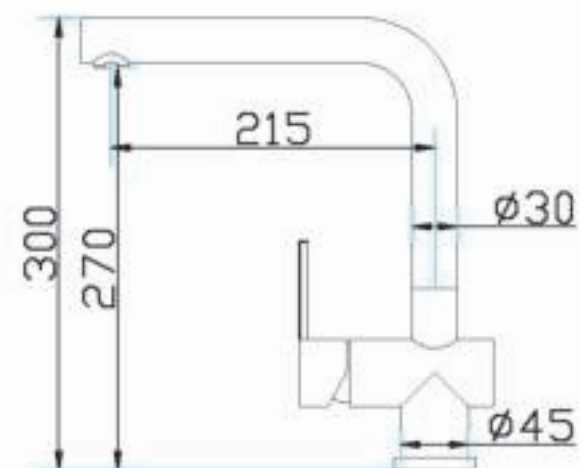

6. Funktionsüberprüfung



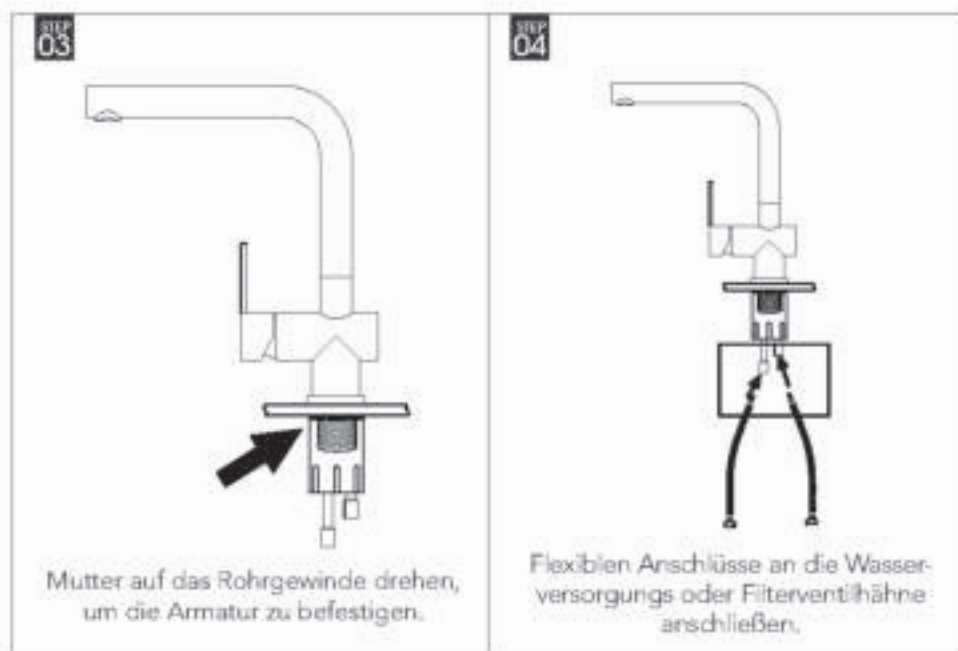
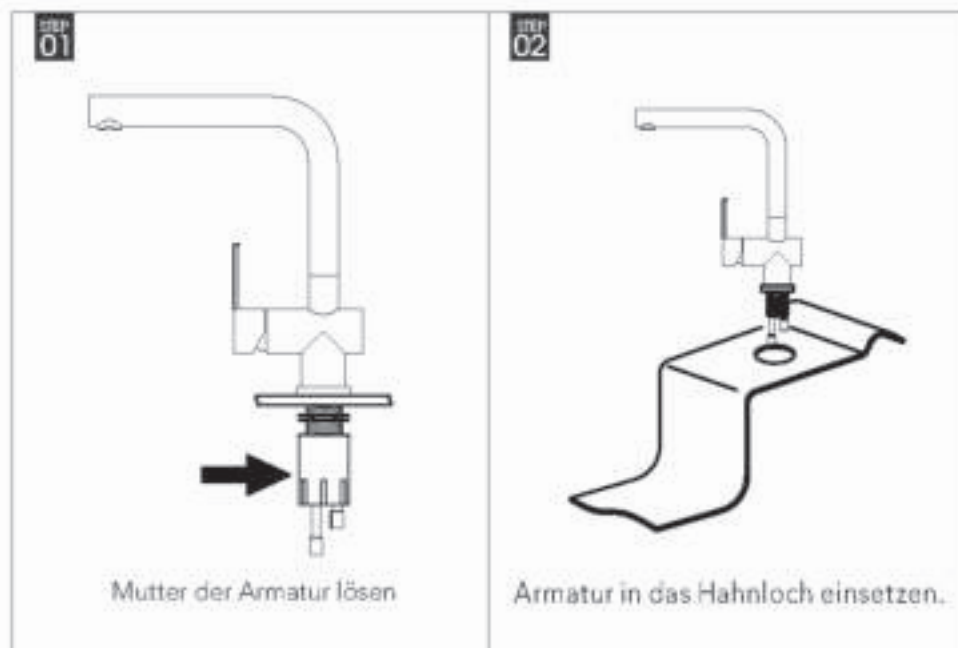

8. Pflege und Wartung

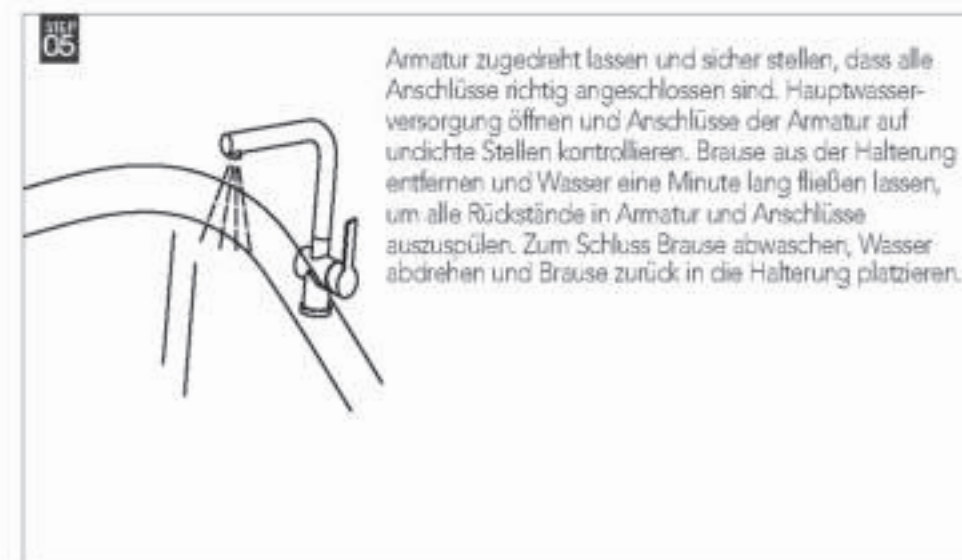

Bei der Installation der Armatur an neue Wasserversorgungsschläuche, wird empfohlen, die Schläuche vor der Installation der Armatur zu durchspülen.

Die Reinigung verschmutzter Armaturen erfordert eine gewisse Vorsicht. Armatur ausschließlich mit einem sauberen und weichen Tuch reinigen. Bei Kalkrückständen wird ein mildes Reinigungsmittel empfohlen. Auf keinen Fall aggressive Reiniger verwenden (Scheuermittel, Chemikalien oder Lösungsmittel wie z.B. Ammoniakwasser, Salzgeist, scharfe Reinigungsmittel oder Reinigungspulver) da dies zu Oberflächenschäden führen kann.

Wasserversorgungsventil ausschalten wenn der Wasserhahn für längere Zeit nicht benutzt wird.

9. Garantie

Seit 2009 entwirft und entwickelt das niederländische Unternehmen Mizzo Designküchenprodukte wie Armaturen und Küchenspülen. Mizzo Design bieten ein komplettes Programm von 100 Designprodukten an. Alle Produkte unterliegen strengsten Qualitätsanforderungen. Die Garantiezeit auf Küchenarmaturen beträgt 5 Jahre und auf Küchenspülen Lebenslang.

1. Informations techniques

Rotation bec	360 degrés
Longueur bec extractible	Jusqu'à 0.5m
Pression d'eau froid et chaud	Min. 0.05 MPa (pression circulant), Max 0.75 MPa (pression statique)
Température d'eau reccomandé	60±5°C - 90°C Attention: n'utilisez pas de vapeur comme eau chaude
Orifice mitigeur	35 mm

2. Outils nécessaires à l'installation



Clé à molette



Mains



Clé Allen



Pince multiprise

3. Articles inclus

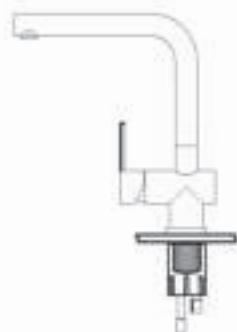

16

4. Pièces détachées

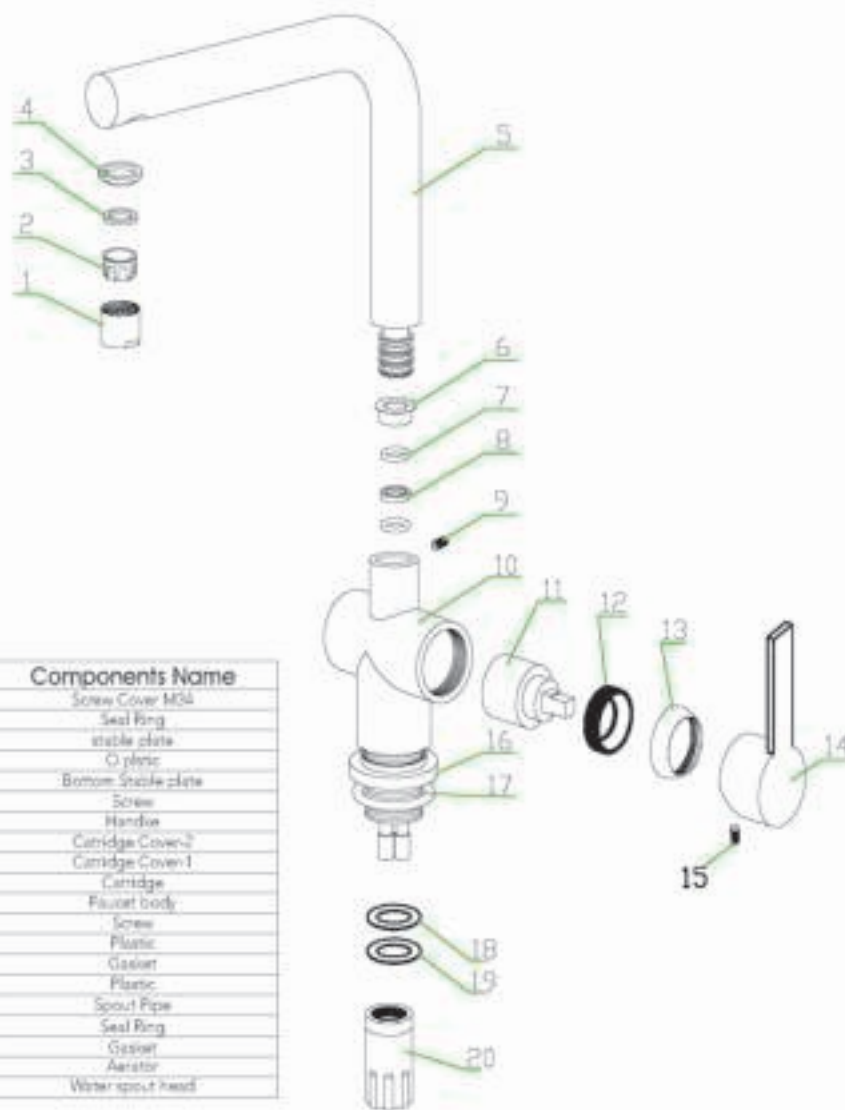

No.	Components Name
20	Screw Cover M04
19	Seal Ring
18	stable plate
17	O ring
16	Bottom Stable plate
15	Screw
14	Handle
13	Cartridge Cover 2
12	Cartridge Cover 1
11	Cartridge
10	Faucet body
9	Screw
8	Plastic
7	Gasket
6	Plastic
5	Spout Pipe
4	Seal Ring
3	Gasket
2	Aerator
1	Water spout head

17

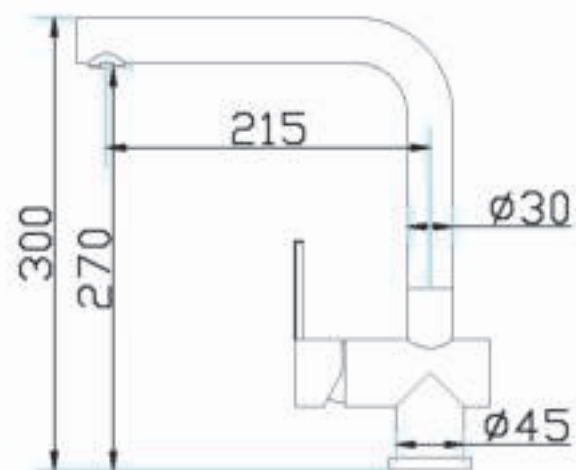

6. Étapes d'installation

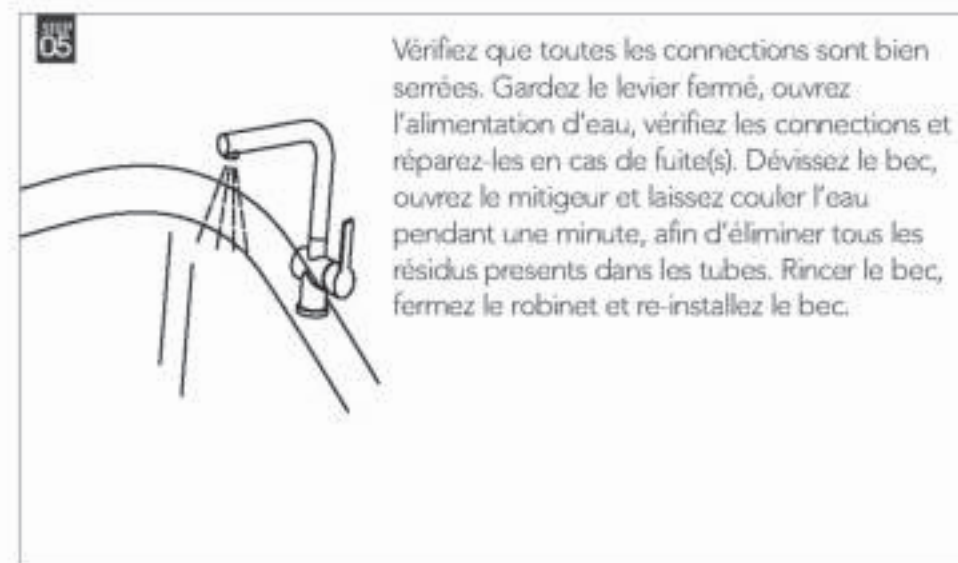
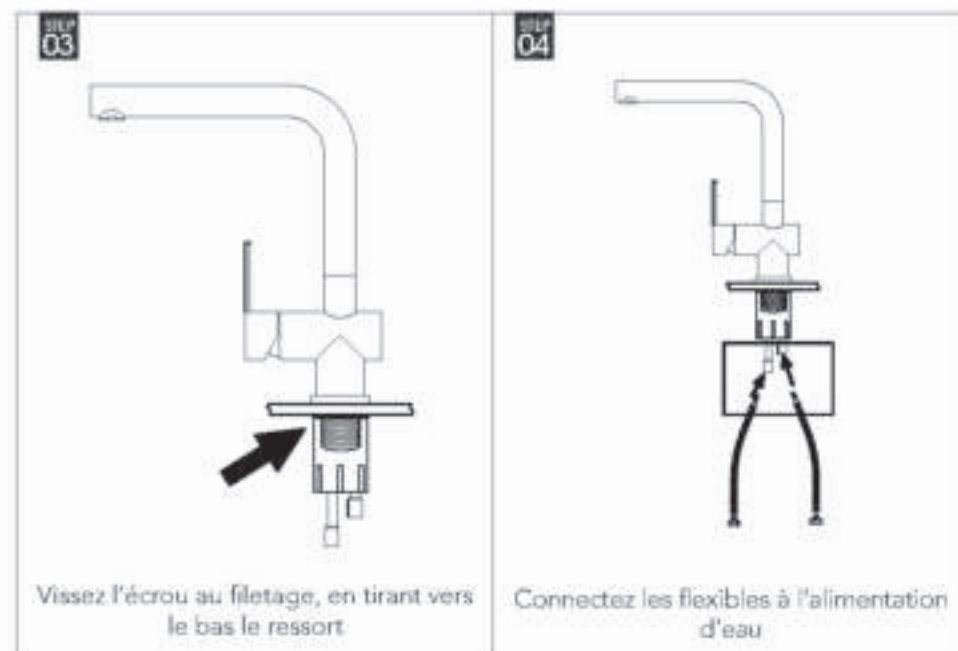
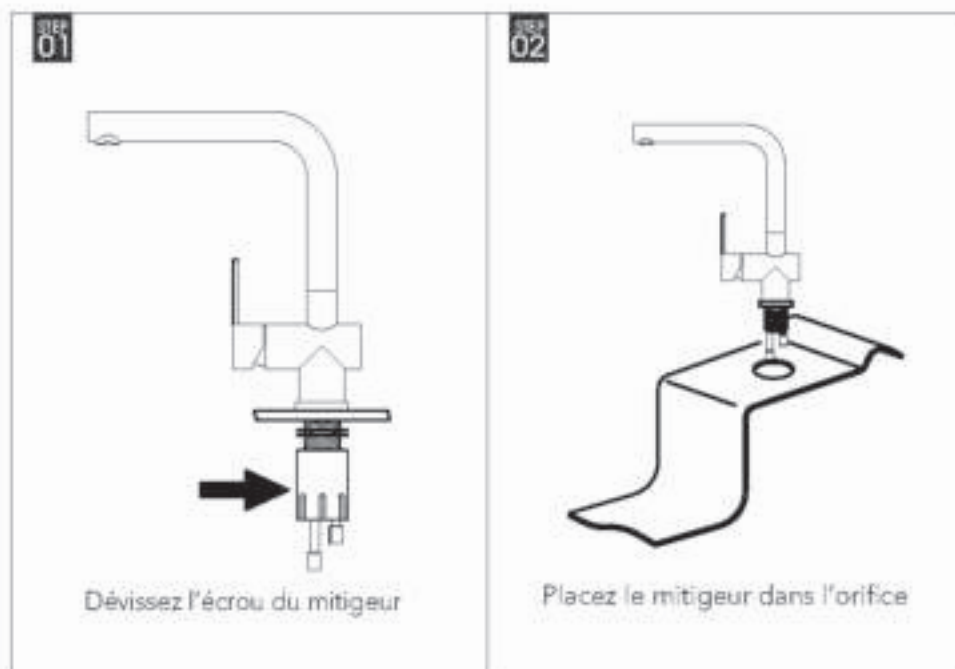

8. Care and maintenance

Quand vous connectez le mitigeur à une alimentation d'eau avec des tubes neufs, il est conseillé de rincer les tubes avant d'installer le mitigeur.

Dans le processus d'utilisation, il convient de veiller à bien entretenir l'article. Utilisez un chiffon doux et humide avec un savon doux pour nettoyer le mitigeur. N'utilisez pas de nettoyeurs abrasifs, de produits chimiques ou de solvants (de l'ammoniac, de l'eau de javel, des nettoyeurs agressifs ou du savon en poudre) vu qu'ils peuvent endommager la surface du mitigeur.

En cas de non-utilisation prolongée on vous conseille de fermer l'alimentation d'eau.

9. Warranty

Mizzo Design est une marque européenne d'origine aux Pays-Bas. Nous tenons à n'utiliser que les meilleurs matériaux dans le processus de fabrication, afin de pouvoir garantir la qualité de nos produits. Nous n'acceptons que le meilleur pour créer le meilleur. Mizzo Design offre une garantie de 5 ans pour les robinets et une garantie vie pour les éviers de cuisine.

1. Informazione tecnica

Canna girevole	360 gradi
Lunghezza doccetta estraibile	Fino a 0.5 m
Pressione di alimentazione dell'acqua fredda e calda	Min. 0.05 MPa (pressione di flusso), Max 0.75 MPa (pressione statica)
Temperatura raccomandata dell'acqua	60±5°C - 90°C Nota: non utilizzare vapore come acqua calda
Diametro foro rubinetto	35 mm

2. Strumenti necessari per l'installazione



Chiave inglese
(regolabile)



Mani



Set chiavi a brugola



Chiave pappagallo
(opzionale)

3. Articoli inclusi



4. Parti del rubinetto

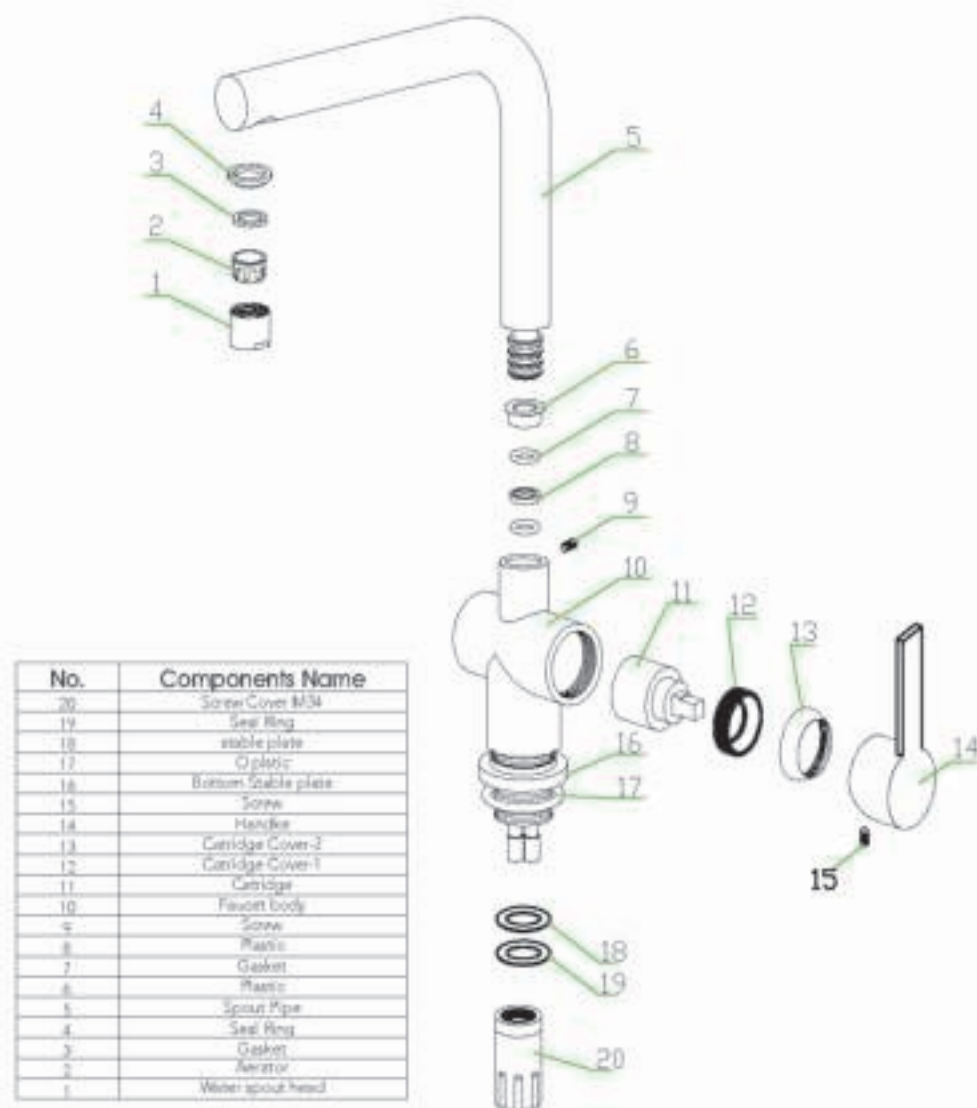

5. Dimensioni

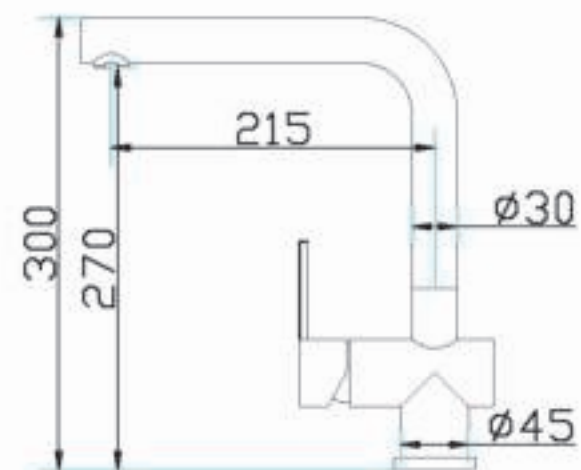

6. Passi di installazione



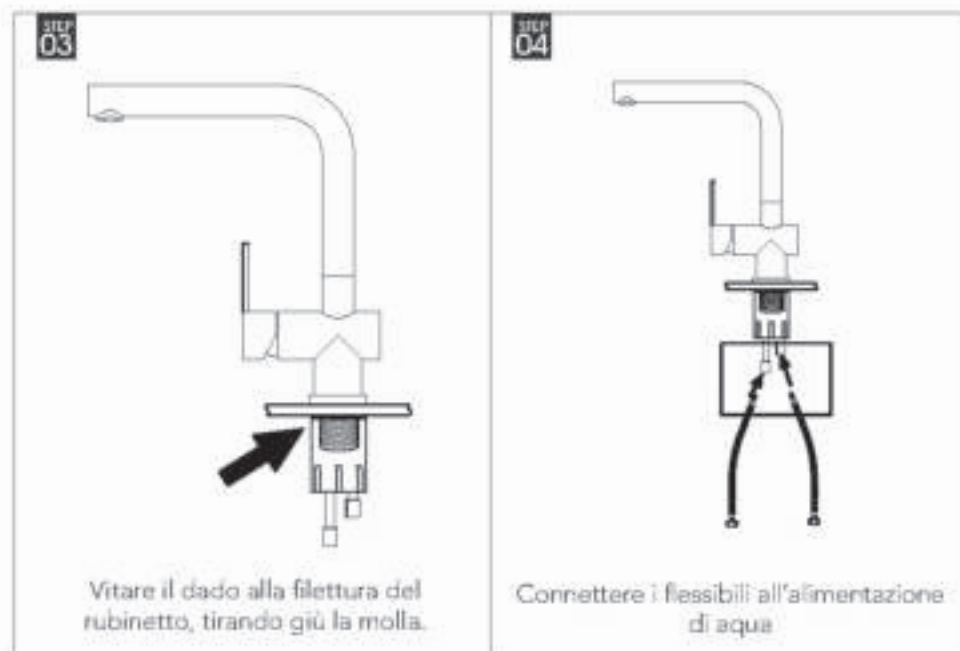
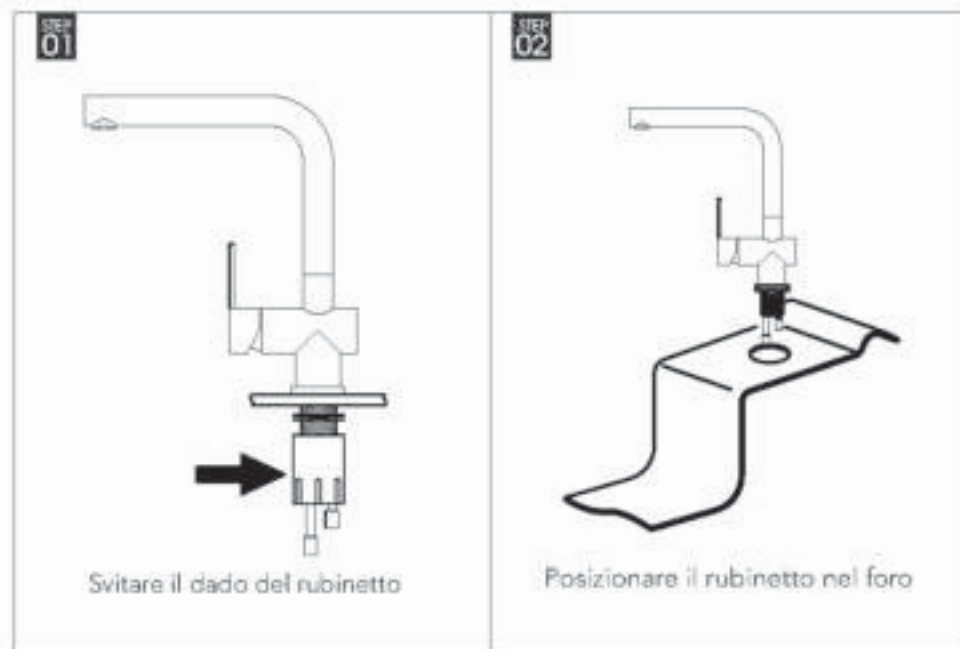

8. Cura e manutenzione

Quando il rubinetto viene installato su un'alimentazione di acqua con tubi nuovi, è consigliato sciacquarli prima dell'installazione.

Nel processo di utilizzo occorre prestare attenzione per la pulizia di questo articolo. È consigliato utilizzare un panno pulito e umido con un sapone neutro. Non utilizzare detersivi abrasivi, prodotti chimici o solventi (ammoniaca, acido cloridrico, detersivi aggressivi o detersivi in polvere), dato che possono danneggiare la superficie.

Quando il rubinetto non viene utilizzato per un periodo lungo consigliamo di chiudere le valvole dell'acqua (l'alimentazione).

9. Garanzia

Da 2009 Mizzo Design, un marchio olandese per accessori da cucina, progetta e sviluppa degli articoli come rubinetti e lavelli da cucina. Nel frattempo ci sono quasi 100 prodotti che devono soddisfare i rigorosi controlli di qualità imposti dalla casa Mizzo Design. Mizzo Design offre una garanzia di 5 anni su tutti i rubinetti da cucina e una garanzia a vita per i lavelli da cucina.