



# Kid Smart Watch User Manual SWK-110



[facebook.com/Denver.eu](https://facebook.com/Denver.eu)

# Safety information

Please read the safety instructions carefully before using the product for the first time and keep the instructions for future reference.

1. Warning: This product includes lithium polymer battery.
2. Keep product out of the reach of children under 36 months and pets to avoid chewing and swallowing.
3. Product operating and storage temperature is from 0 degree Celsius to 40 degree Celsius.
4. Under and over this temperature might affect the function.
5. Never open the product. Repairs or service should only be performed by qualified personnel.
6. Do not use for water depth below 1 meters!
7. Please remove the Smart watch from arm in case of any leakage or excessive heat from the product to avoid burns or rash.
8. Using other accessories than the ones delivered with the product can cause abnormal functionality.

**IMPORTANT!** BPM-Heart Rate-Blood Oxygen app measurements are not intended for medical use, including self diagnosis or consultation with a doctor, and are only designed for general fitness and wellness purposes. This is not a medical diagnostic device.

# Download the APP

**Please Scan to Download the App: JYOU PRO**



Your mobile phone system requirements:

- iOS 10 and above
- Android 5.0 and above
- Support Bluetooth 4.0

# Usage Instructions

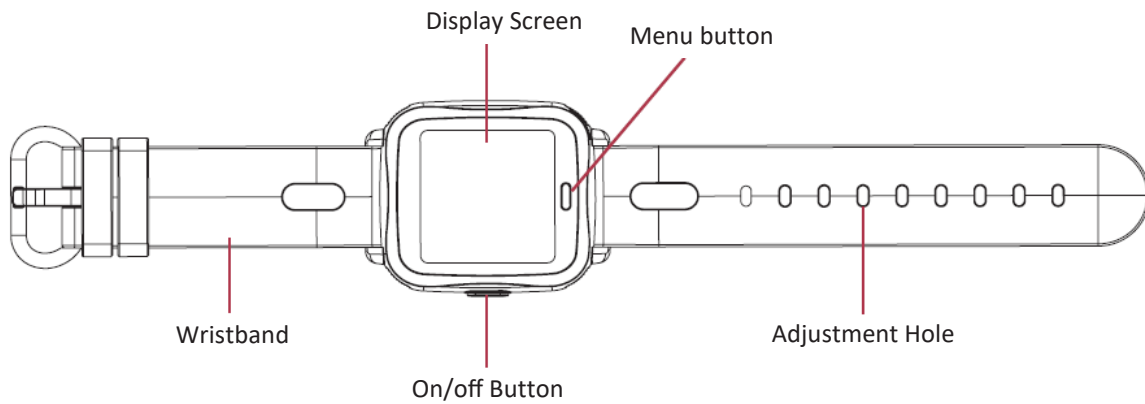

## Power On/Off

### 1. Power On

To press and hold the power-on button for 3 seconds, then watch screen will light up with vibration;

### 2. Power Off

Get to watch setting page and find shutdown menu, then click to turn it off; or press and hold the power-on button for 3 seconds, then the watch will vibrate and shut down.

## How to Charge the Watch

Please use the standard magnetic charging cable to charge your smartwatch, and the watch will automatically turn on when charging. (The charging method is as shown below, the charging voltage is 5V.)

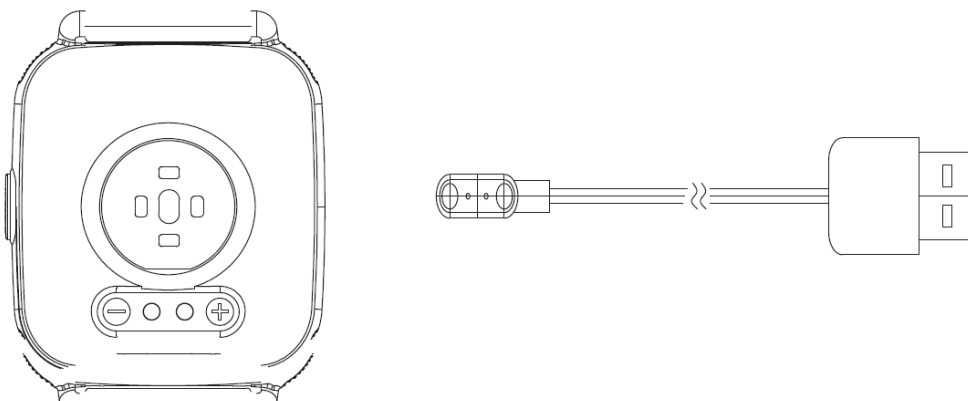

# How to Connect the Watch

For first time using, you need to connect to the APP for setting. After successfully connected, the watch will automatically synchronize the time, otherwise the pedometer data and sleep data will be inaccurate.

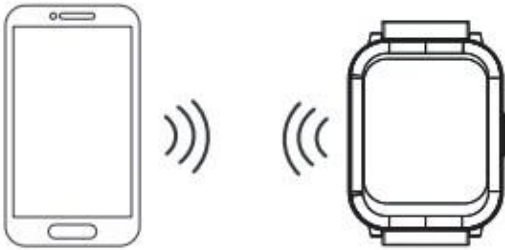

- Open the APP (JYouPro) and click the device icon
- Add device (iOS)/(Android)
- Click the scanning device icon
- Click the BT named "SWK-110" to connect to the device

## Data Synchronization:

On the APP home page, refresh to synchronize data. The watch can store the offline data for 7 days, the more data, the longer synchronization time, Max time of synchronizing is about 2 minutes, after the synchronization is completed, there will be a "synchronization complete" showed on the screen.

# Home Screen

The watch has multiple clock design. You can switch it after a long press for 3 seconds.

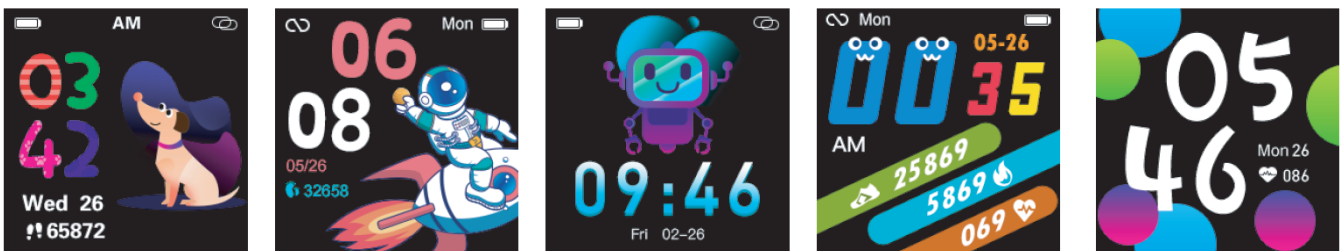

# Pedometer

Click the function key to switch to the status interface to view the status of the current steps.

The distance and calories are calculated and displayed according to the current walking steps and the height and weight set by the app.

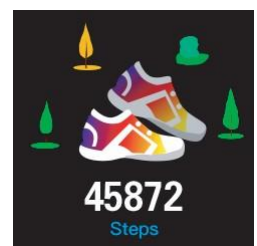

# Mileage

In the menu interface, click the function key to switch to the status interface to view the current mileage.



# Kilocalorie

Click the function key to switch to the kilocalorie interface to view the current calorie consumption.

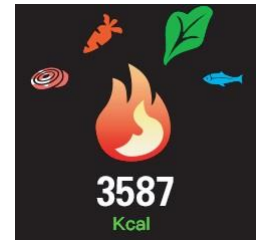

# Heart Rate

Click the function key to switch to the heart rate interface and enter the heart rate detection. After the test, press the key to exit the heart rate detection. Please connected the APP and wear the smart watch in correct way. During the test, the heart rate led on the back of the bracelet will flash;

- The sensor should be close to the skin to avoid the influence of external light on the accuracy of the test;
- Keep the test area clean, sweat or stains will affect the test results

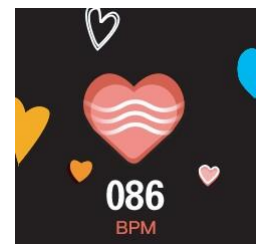

# Blood oxygen

Click the function key to switch the screen to the blood oxygen interface and start the blood oxygen test. After the blood oxygen test, press the key to exit the blood oxygen mode. If the test result is not found, the result of the last test will be displayed or "--" please check whether you wear it well or retest.



# Sports

- Click the function key to switch the specific movement interface.
- Long press the function key to start (stop) the current function.
- After stopping, press the key to exit.

Including walking, running, cycling, badminton, basketball, football, rope skipping, mountaineering and many other sports.

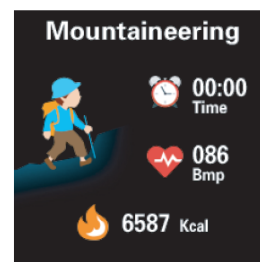
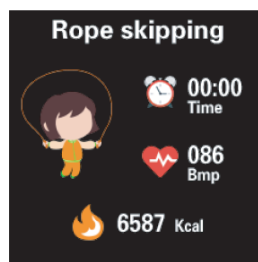
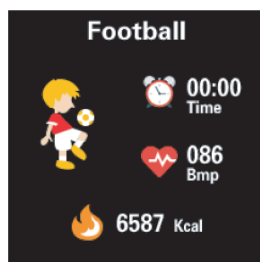
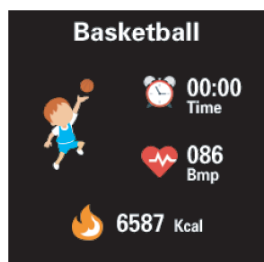
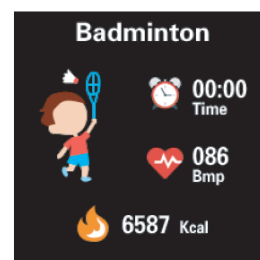
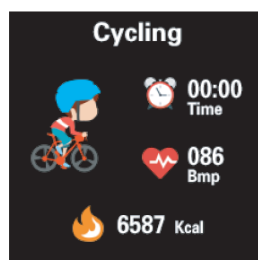
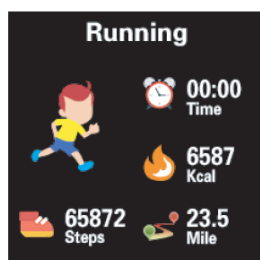
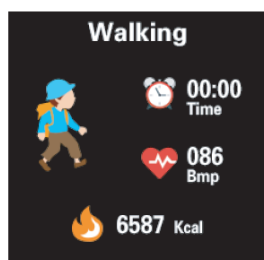

# Sleep

Please wear the smart watch go to sleep, then will had the sleep data in the APP

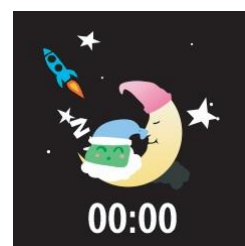

# Stopwatch

Click the function key to make the screen enter the stopwatch function interface, long press the function key to enter the stopwatch function, click the function key to start (pause) the stop watch timing function, long press the function to return to the main menu, and press the key to exit.



# Message push interface

Click the function key to view the history information. If there is no history information, it will be displayed as (0).

After long press to view the information, press the key to exit.

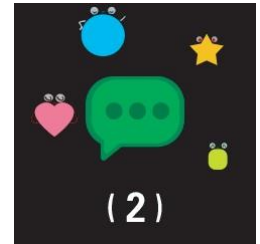

# Setting interface

Click the function key to make the screen enter the setting function interface. Long press to enter the lower menu interface for more function operations.



# Brightness adjustment

Long press the function key to enter, then click the function key to select different brightness, there are four levels of brightness.

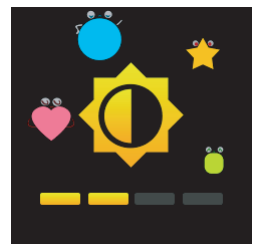

# Find your phone

When the watch is connected, long press the function key in the search interface, and the phone will ring.



# Shut down

In this interface, press the function key for three seconds, and the bracelet will turn off.

Ring vibration (low power, no vibration)

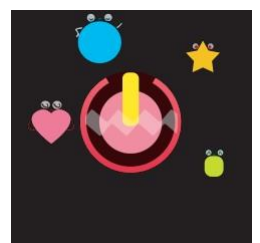

# FAQ

## 1. What if Bluetooth doesn't connect (Connection / reconnection failure or slow reconnection speed)?

Please make sure the smart phone version is IOS10 & Android 5.0 or above and support the Bluetooth 4.0

- 1). Due to signal interference in Bluetooth wireless connection, the connection time may vary. If you can't connect it for a long time, please make sure that the operation is free of magnetic field or interference from multiple Bluetooth devices conduct;
- 2). Turn off Bluetooth and turn it on again;
- 3). Close the background application or restart the mobile phone;
- 4). Don't connect other Bluetooth devices or functions at the same time;
- 5). Whether the app is running normally in the background. If it is not in the background, it may not be connected

## 2. Can't find the bracelet?

Because the bracelet is not searched by the mobile phone during Bluetooth broadcast, please make sure that the bracelet is powered on and activated. If it is still invalid, please turn off Bluetooth and restart Bluetooth after 20 seconds.



Please notice -All products are subject to change without any notice.  
We take reservations for errors and omissions in the manual.

ALL RIGHTS RESERVED, COPYRIGHT DENVER AS



denver.eu



Electric and electronic equipment and included batteries contains materials, components and substances that can be hazardous to your health and the environment, if the waste material (discarded electric and electronic equipment and batteries) is not handled correctly.

Electric and electronic equipment and batteries is marked with the crossed out trash can symbol, seen above. This symbol signifies that electric and electronic equipment and batteries should not be disposed of with other household waste, but should be disposed of separately.

As the end user it is important that you submit your used batteries to the appropriate and designated facility. In this manner you make sure that the batteries are recycled in accordance with legislature and will not harm the environment.

All cities have established collection points, where electric and electronic equipment and batteries can either be submitted free of charge at recycling stations and other collection sites, or be collected from the households. Additional information is available at the technical department of your city.

Hereby, Denver AS declares that the radio equipment type SWK-110 is in compliance with Directive 2014/53/EU. The full text of the EU declaration of conformity is available at the following internet address: [denver.eu](http://denver.eu) and then click the search ICON on topline of website.

Write model number: SWK-110. Now enter product page, and RED directive is found under downloads/other downloads.

Operating Frequency Range: 2412-2484 MHZ

Max Output Power: 0.555W

Denver AS  
Omega 5A, Soefthen  
DK-8382 Hinnerup  
Denmark

[facebook.com/Denver.eu](https://facebook.com/Denver.eu)