

cecotec

**Power Moca Spume 5000**

Espumador de leche/Milk frother



Manual de instrucciones  
Instruction manual  
Manuel d'instructions  
Bedienungsanleitung  
Manuale di istruzioni  
Manual de instruções





## ÍNDICE

1. Piezas y componentes	/ 04
2. Instrucciones de seguridad	/ 06
3. Antes de usar	/ 07
4. Funcionamiento	/ 07
5. Limpieza y mantenimiento	/ 11
6. Especificaciones técnicas	/ 12
7. Reciclaje de electrodomésticos	/ 12
8. Garantía y SAT	/ 13

## INHALT

1. Teile und Komponenten	/ 04
2. Sicherheitshinweise	/ 29
3. Bevor dem ersten Gebrauch	/ 30
4. Betrieb	/ 30
5. Reinigung und Wartung	/ 34
6. Technische Spezifikationen	/ 35
7. Entsorgung von alten Elektrogeräten	/ 35
8. Technischer Kundendienst und Garantie	/ 36

## INDEX

1. Parts and components	/ 04
2. Safety instructions	/ 14
3. Before use	/ 15
4. Operation	/ 15
5. Cleaning and maintenance	/ 18
6. Technical specifications	/ 19
7. Disposal of old electrical appliances	/ 20
8. Technical support service and warranty	/ 20

## INDICE

1. Parti e componenti	/ 04
2. Istruzioni di sicurezza	/ 37
3. Prima dell'uso	/ 38
4. Funzionamento	/ 38
5. Pulizia e manutenzione	/ 41
6. Specifiche tecniche	/ 43
7. Riciclaggio degli elettrodomestici	/ 43
8. Garanzia e SAT	/ 43

## SOMMAIRE

1. Pièces et composants	/ 04
2. Instructions de sécurité	/ 21
3. Avant utilisation	/ 22
4. Fonctionnement	/ 22
5. Nettoyage et entretien	/ 26
6. Spécifications techniques	/ 27
7. Recyclage des électroménagers	/ 27
8. Garantie et SAV	/ 28

## ÍNDICE

1. Peças e componentes	/ 04
2. Instruções de segurança	/ 44
3. Antes de usar	/ 45
4. Funcionamento	/ 45
5. Limpeza e manutenção	/ 49
6. Especificações técnicas	/ 50
7. Reciclagem de eletrodomésticos	/ 50
8. Garantia e SAT	/ 50





## 1. PIEZAS Y COMPONENTES

Parts and components/Pièces et composants/Teile und Komponenten/  
Parti e componenti/Peças e componentes

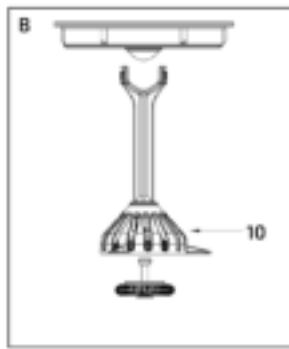
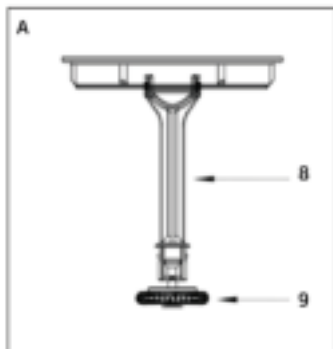
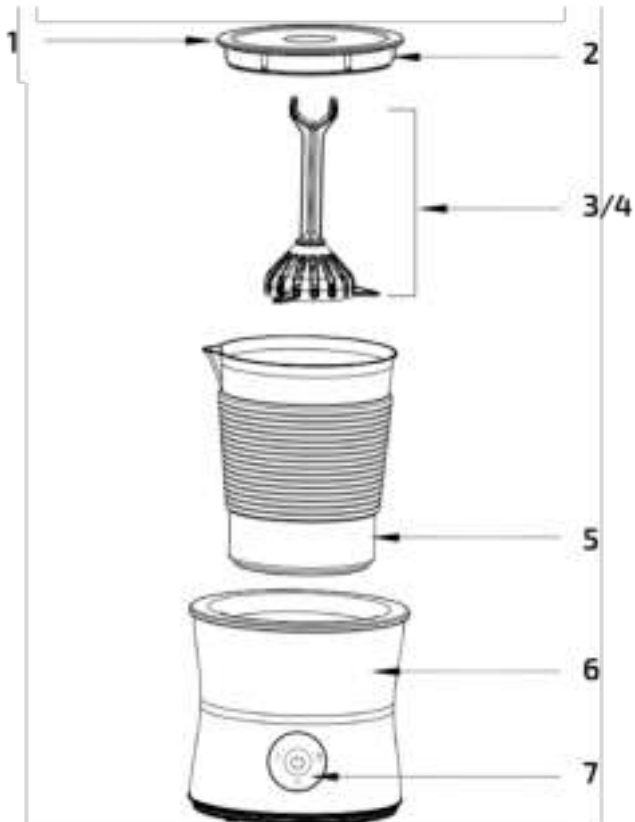



## ES

1. Tapa
2. Aro de sellado
3. Accesorio para leche
4. Accesorio para chocolate 1
5. Jarra
6. Base calefactora con hueco recogecables
7. Botón de encendido y selector de función
8. Asa
9. Varilla con muelle de acero inoxidable
10. Accesorio para chocolate 2

## EN

1. Lid
2. Sealing ring
3. Milk accessory
4. Chocolate accessory 1
5. Jug
6. Heating base with cord-winder tab
7. Power button and function selector
8. Handle
9. Whisk with stainless-steel spring
10. Chocolate accessory 2

## FR

1. Couvercle
2. Anneau de scellage
3. Accessoire pour lait
4. Accessoire pour chocolat 1
5. Jarre
6. Base chauffante avec espace range-câbles
7. Bouton de connexion et sélecteur de fonction
8. Poignée
9. Tige à ressort en acier inoxydable
10. Accessoire pour chocolat 2

## DE

1. Deckel
2. Dichtungsring
3. Zubehör für Milch
4. Zubehör für Schokolade
5. Milchaufschäumer
6. Basis mit Kabelaufwicklung
7. Start/Stop Taste
8. Griff
9. Aufsatz für heiße Milch aus Edelstahl
10. Zubehör für Schokolade 2

## IT

1. Coperchio
2. Anello di sigillo
3. Accessorio per il latte
4. Accessorio per la cioccolata 1
5. Caraffa
6. Base riscaldante con vano salva-cavo
7. Tasto di accensione e selettore di funzionamento
8. Manico
9. Accessorio con molla in acciaio inossidabile
10. Accessorio per la cioccolata 2

## PT

1. Tampa
2. Aro de selado
3. Acessório para leite
4. Acessório para chocolate 1
5. Jarra
6. Base elétrica com espaço para guardar o cabo
7. Botão de ligar e seletor de função
8. Asa
9. Vara com mola de aço inoxidável
10. Acessório para chocolate 2





## **ESPAÑOL**

### **2. INSTRUCCIONES DE SEGURIDAD**

Lea las siguientes instrucciones atentamente antes de usar el producto. Guarde este manual para referencias futuras o nuevos usuarios.

1. Asegúrese de que el voltaje de red coincida con el voltaje especificado en la etiqueta de clasificación del producto y de que el enchufe tenga toma de tierra.
2. Este dispositivo está diseñado solo para uso doméstico. No lo utilice para fines comerciales o industriales.
3. No sumerja el cable, el enchufe ni ninguna otra parte fija del grill en agua o cualquier otro líquido. No exponga las conexiones eléctricas al agua. Asegúrese de que tiene las manos completamente secas antes de tocar el enchufe o encender el grill.
4. Inspeccione el cable de alimentación regularmente en busca de daños visibles. Si el cable presenta daños, debe ser reparado por el Servicio de Asistencia Técnica oficial de Cecotec para evitar cualquier tipo de peligro.
5. Limpie todas las superficies que hayan estado en contacto con los alimentos después de cada uso.
6. Las superficies accesibles podrían alcanzar temperaturas muy elevadas durante e inmediatamente después de funcionar. Utilice guantes o cualquier otro tipo de protección para evitar quemaduras.
7. Utilice este aparato únicamente con la jarra y los accesorios que se le proporcionen con el producto.
8. No ponga en funcionamiento el aparato sin la jarra o con la jarra vacía.
9. No retuerza, doble, estire o dañe el cable de alimentación. Protéjalo de bordes afilados y fuentes de calor. No permita que el cable toque superficies calientes. No deje que el cable asome sobre el borde de la superficie de trabajo o la encimera.
10. Nunca desconecte el cable de alimentación tirando del cable ni con las manos mojadas.
11. No utilice el dispositivo en el exterior, dentro o encima de cocinas eléctricas, hornos calientes o cerca de fuego.
12. No deje el aparato en funcionamiento sin supervisión.
13. Este espumador está diseñado para calentar y espumar leche o chocolate. No intente espesar o calentar otros alimentos como nata, crema, salsas, agua, etc.
14. El producto debe tener la tapa puesta siempre que esté funcionando.
15. No mueva ni traslade el aparato mientras esté en funcionamiento.
16. El aparato no debe ser usado por niños desde 0 hasta 8 años. Este electrodoméstico puede ser usado por niños de 8 años de edad y mayores de 8 años si están continuamente supervisados.
17. Este producto puede ser usado por personas con capacidades físicas, sensoriales o mentales reducidas, o con falta de experiencia y conocimiento si están supervisados o han recibido instrucción concerniente al uso del aparato de una forma segura y entienden los riesgos que este implica.



18. Supervise a los niños para asegurarse de que no jueguen con el producto. Es necesario dar una supervisión estricta si el producto está siendo usado por o cerca de niños.







### 3. ANTES DE USAR

- Saque el producto de la caja y retire todo el material del embalaje.
- Limpie la jarra y los accesorios como se explica en la sección de "Limpieza y mantenimiento".
- Antes de poner el producto en funcionamiento, seque minuciosamente todas sus partes, en especial la zona de debajo de la base.
- Desenrolle completamente el cable.
- Conecte el cable de alimentación a un enchufe con toma de tierra, la luz roja se encenderá.

### 4. FUNCIONAMIENTO

Este espumador está diseñado para espumar y calentar leche y chocolate. Los tipos de leche compatibles son los siguientes:

- Leche fresca.
- Leche UHT (de vaca, oveja y cabra).
- Leche sin lactosa.
- Leche de soja y otras alternativas.



Icono	Función	Uso	Accesorio	Cantidad
	Espumar leche caliente.	Una espuma gruesa es perfecta para el cappuccino o latte macchiato.		Mín.: 100 ml Máx.: 200 ml
	Espumar leche fría.	Una espuma cremosa y fría es perfecta para frappés, cócteles, café helado o postres.		Mín.: 100 ml Máx.: 200 ml
	Leche caliente.	Esta función calienta la leche de manera muy fácil y rápida. Es perfecta para café latte o vasos de leche caliente.		Mín.: 100 ml Máx.: 400 ml
	Chocolate caliente.	Esta función prepara chocolate caliente con chocolate troceado.		Mín.: 100 ml Máx.: 300 ml Chocolate: máx. 34 g



## **ESPAÑOL**

### **Espumar leche caliente**



**Aviso:** para esta función utilice el accesorio para leche.

1. Introduzca el accesorio para leche en la jarra de forma vertical. La base incluye un imán que mantendrá el accesorio sujeto.
2. Llene la jarra de leche y asegúrese de que está por encima de la marca de MÍN. y no excede la marca de MÁX.
3. Coloque la jarra sobre la base calefactora.
4. Cierre la jarra con la tapa y asegúrese de que la parte final del accesorio para leche encaje correctamente en la tapa. Apriete ligeramente la tapa hasta asegurarse de que está totalmente cerrada.
5. Pulse el botón  hasta que se encienda la luz roja.
6. El aparato se apagará de forma automática a los 4 minutos, pero también puede apagarse manualmente en cualquier momento al pulsar .

**Aviso:** es posible que el ventilador del motor continúe en marcha después de haber acabado el proceso.

### **Espumar leche fría**

**Aviso:** para esta función utilice el accesorio para leche.



1. Introduzca el accesorio para leche en la jarra de forma vertical. La base incluye un imán que mantendrá el accesorio sujeto.
2. Llene la jarra de leche y asegúrese de que está por encima de la marca de MÍN. y no excede la marca de MÁX.
3. Coloque la jarra sobre la base calefactora.
4. Cierre la jarra con la tapa y asegúrese de que la parte final del accesorio para leche encaje correctamente en la tapa. Apriete ligeramente la tapa hasta asegurarse de que está totalmente cerrada.
5. Pulse el botón  hasta que se encienda la luz azul.
6. El aparato se apagará de forma automática a los 3 minutos, pero también puede apagarse manualmente en cualquier momento al pulsar .

**Aviso:** es posible que el ventilador del motor continúe en marcha después de haber acabado el proceso.



### Calentar leche



**Aviso:** para esta función utilice el accesorio para leche.

1. Introduzca el accesorio para leche sin el muelle de acero inoxidable en la jarra de forma vertical. La base incluye un imán que mantendrá el accesorio sujeto.
2. Llene la jarra de leche y asegúrese de que está por encima de la marca de MÍN. y no excede la marca de MÁX.
3. Coloque la jarra sobre la base calefactora.
4. Cierre la jarra con la tapa y asegúrese de que la parte final del accesorio para leche encaje correctamente en la tapa. Apriete ligeramente la tapa hasta asegurarse de que está totalmente cerrada.
5. Pulse el botón  hasta que se encienda la luz roja.
6. El aparato se apagará de forma automática a los 5 minutos, pero también puede apagarse manualmente en cualquier momento al pulsar .

**Aviso:** es posible que el ventilador continúe en marcha después de haber acabado el proceso.

### Preparar chocolate caliente

**Aviso:** para esta función utilice los accesorios para chocolate.

1. Introduzca el accesorio para leche en la jarra de forma vertical. La base incluye un imán que mantendrá el accesorio sujeto.
2. Llene la jarra de leche y asegúrese de que está por encima de la marca de MÍN. y no excede la marca de MÁX.
3. Añada chocolate troceado a la leche. Se recomienda cortar trozos pequeños para obtener un resultado óptimo. También se puede utilizar chocolate molido o en polvo.
4. Cierre la jarra con la tapa y asegúrese de que la parte final del accesorio para leche encaje correctamente en la tapa. Apriete ligeramente la tapa hasta asegurarse de que está totalmente cerrada.
5. Pulse el botón  hasta que se encienda la luz morada.
6. El aparato se apagará de forma automática a los 6.5 minutos, pero también puede apagarse manualmente en cualquier momento al pulsar .

**Aviso:** es posible que el ventilador continúe en marcha después de haber acabado el proceso.



▶ **ESPAÑOL**

**Accesorios**

Accesorio para espumar leche caliente y fría



Accesorio para leche caliente (sin muelle)

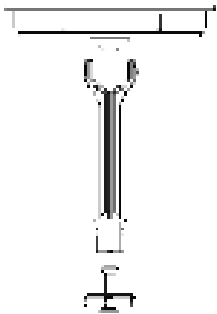

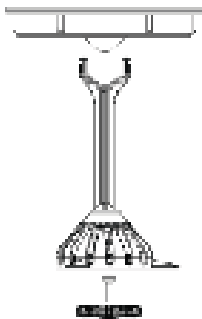

Accesorios para chocolate caliente (con muelle)





### 5. LIMPIEZA Y MANTENIMIENTO

- Apague el espumador, desconéctelo y permita que se enfríe antes de proceder a la limpieza o a guardarlo.
- Retire el aro de sellado de la tapa para una mejor limpieza.
- Retire todos los accesorios de dentro de la jarra y límpielos por separado.
- No utilice esponjas, polvos o productos de limpieza abrasivos para limpiar tanto el aparato como sus accesorios.
- Limpie el espumador y los accesorios después de cada uso.

			
Tapa	✓	✓	✓
Aro de sellado	✓	✓	✓
Accesorios para leche y chocolate	✓	✓	✓
Jarra	✓	✓	✓
Base calefactora	—	—	✓





 **ESPAÑOL**

## 6. ESPECIFICACIONES TÉCNICAS

Modelo: Power Moca Spume 5000

Referencia del producto: 01518

Potencia: 650 W

Voltaje y frecuencia: 220-240 V, 50/60 Hz

Made in China | Diseñado en España

## 7. RECICLAJE DE ELECTRODOMÉSTICOS



La directiva europea 2012/19/UE sobre Residuos de Aparatos Eléctricos y Electrónicos (RAEE) especifica que los electrodomésticos no deben ser reciclados con el resto de los desperdicios municipales. Dichos electrodomésticos han de ser desechados de forma separada, para optimizar la recuperación y reciclaje de materiales y, de esta manera, reducir el impacto que puedan tener en la salud humana y el medioambiente.

El símbolo del contenedor tachado le recuerda su obligación de desechar este producto de forma correcta. Si el producto en cuestión cuenta con una batería o pila para su autonomía eléctrica, esta deberá extraerse antes de ser desechado y ser tratada a parte como un residuo de diferente categoría.

Para obtener información detallada acerca de la forma más adecuada de desechar sus electrodomésticos y/o las correspondientes baterías, el consumidor deberá contactar con las autoridades locales.

## 8. GARANTÍA Y SAT

Este producto tiene una garantía de 2 años desde la fecha de compra, siempre y cuando se conserve y envíe la factura de compra, el producto esté en perfecto estado físico y se le dé un uso adecuado tal y como se indica en este manual de instrucciones.

La garantía no cubrirá:

- Si el producto ha sido usado fuera de su capacidad o utilidad, maltratado, golpeado, expuesto a la humedad, sumergido en algún líquido o sustancia corrosiva, así como cualquier otra falta atribuible al consumidor.
- Si el producto ha sido desarmado, modificado o reparado por personas no autorizadas por el SAT oficial de Cecotec.
- Si la incidencia ha sido originada por el desgaste normal de las piezas debido al uso.

El servicio de garantía cubre todos los defectos de fabricación durante 2 años en base a la legislación vigente, excepto piezas consumibles. En caso de mal uso por parte del usuario el servicio de garantía no se hará responsable de la reparación. Si en alguna ocasión detecta una incidencia con el producto o tiene alguna consulta, póngase en contacto con el Servicio de Asistencia Técnica oficial de Cecotec a través del número de teléfono **+34 96 321 07 28**.



## **ENGLISH**

### **2. SAFETY INSTRUCTIONS**

Read these instructions thoroughly before using the appliance. Keep this instruction manual for future reference or new users.

1. Make sure that the mains voltage matches the voltage stated on the rating label of the appliance and that the wall outlet is grounded.
2. This appliance is designed for household only. Do not use it for commercial or industrial purposes.
3. Do not immerse the cord, plug, or any non-removable part of the appliance in water or any other liquid, nor expose the electrical connections to water. Make sure your hands are dry before handling the plug or switching on the appliance.
4. Check the power cord regularly for visible damage. If the cord is damaged, it must be replaced by the official Technical Support Service of Cecotec in order to avoid any type of danger.
5. Clean all the surfaces that have been in contact with food after every use.
6. Accessible surfaces can become very hot during and immediately after operation. Use gloves or any other type of protection in order to avoid burns.
7. This appliance can only be operated with jug and accessories provided.
8. Do not operate the appliance without jug or empty.
9. Do not twist, bend, strain, or damage the power cord in any way. Protect it from sharp edges and heat sources. Do not let it touch hot surfaces. Do not let the cord hang over the edge of the working surface or countertop.
10. Never disconnect the mains plug from the socket by the cord or with wet hands.
11. Do not use outdoors, near a gas or electric hob, in heated ovens or near open flames.
12. Do not leave the appliance unattended whilst in use.
13. This milk frother is designed for heating and frothing milk or chocolate. It is not intended to thicken or heat other foods such as cream, custard, gravies, water etc.
14. The lid must always be placed on the jug during operation.
15. Do not move the device during operation.
16. The appliance is not intended to be used by children under the age of 8. It can be used by children over the age of 8, as long as they are given continuous supervision.
17. This appliance can be used by children aged 8 and above, and persons with reduced physical, sensory or mental capabilities or lack of experience and knowledge, as long as they have been given supervision or instruction concerning the use of the appliance in a safe way and understand the hazards involved. Children shall not play with the appliance.
18. Supervise young children to make sure that they do not play with the appliance. Close supervision is necessary when the appliance is being used by or near children.









### 3. BEFORE USE

- Take the product out of the box and remove all packaging materials.
- Clean the jug and the accessories as it is explained in the "Cleaning and maintenance" section.
- Thoroughly dry all the parts of the appliance, especially the bottom part of the product's base, before operating.
- Unwind the power cord completely.
- Connect the power cord to an earthed socket, the red power light will turn on.

### 4. OPERATION

This milk frother is intended for frothing and heating milk and chocolate. The following types of milks are suitable for this appliance:

- Fresh milk
- UHT milk (cows, sheep and goats)
- Lactose-free milk
- Soya milk and other alternatives



Symbol	Function	Application	Accessory	Quantities
	Hot milk froth	Thick froth is perfect for cappuccino or latte macchiato.		MIM 100 ml MAX 200 ml
	Cold milk froth	Cold, creamy froth is perfect for frappe drinks, cocktails, iced coffee or deserts.		MIM 100 ml MAX 200 ml
	Hot milk	This function heats up milk in a fast and easy way. Perfect for latte coffees or cups of warm milk.		MIN 100 ml MAX 400 ml
	Hot chocolate	This function prepares hot chocolate with chopped chocolate.		MIN 100 ml MAX 300 ml Chocolate MAX 34 g



## **ENGLISH**

### **Preparing hot milk froth**



**Note:** use the milk accessory for this function.

1. Introduce the milk accessory vertically in the jug. A magnet will attach it to the product's base.
2. Fill the jug with milk, making sure it is over the MIN mark and that it does not exceed the MAX mark.
3. Place the jug on the heating base.
4. Close the jug with the lid and make sure the milk accessory's end fits properly in the lid. Slightly press the lid to ensure it is properly closed.
5. Press the power button  until the red light turns on.
6. The device will automatically turn off after approximately 4 minutes, but it can be stopped manually at any moment by pressing .

**Note:** the device's fan may continue to run after the process has finished.

### **Preparing cold milk froth**



**Note:** use the milk accessory for this function.

1. Introduce the milk accessory vertically in the jug. A magnet will attach it to the product's base.
2. Fill the jug with milk, making sure it is over the MIN mark and that it does not exceed the MAX mark.
3. Place the jug on the heating base.
4. Close the jug with the lid and make sure the milk accessory's end fits properly in the lid. Slightly press the lid to ensure it is properly closed.
5. Press the button  until the blue light turns on.
6. The device will automatically turn off after approximately 3 minutes, but it can be stopped manually at any moment by pressing .

**Note:** the device's fan may continue to run after the process has finished.

### **Preparing hot milk**

**Note:** use the milk accessory for this function.

1. Introduce the milk accessory, without the stainless-steel spring, vertically in the jug. A magnet will attach it to the product's base.
2. Fill the jug with milk, making sure it is over the MIN mark and that it does not exceed the MAX mark.
3. Place the jug on the heating base.
4. Close the jug with the lid and make sure the milk accessory's end fits properly in the lid. Slightly press the lid to ensure it is properly closed.
5. Press the button  until the red light turns on.
6. The device will automatically turn off after approximately 5 minutes, but it can be stopped manually at any moment by pressing .



**Note:** the device's fan may continue to run after the process has finished.





### Preparing hot chocolate

**Note:** use the chocolate accessories for this function.

1. Introduce the milk accessory together with the chocolate accessories vertically in the jug. A magnet will attach it to the product's base.
2. Fill the jug with milk, making sure it is over the MIN mark and that it does not exceed the MAX mark.
3. Add chopped chocolate to the milk. For optimal results, it is suggested to break chocolate into small pieces. Ground or powdered chocolate is also suitable.
4. Close the jug with the lid and make sure the milk accessory's end fits properly in the lid. Slightly press the lid to ensure it is properly closed.
5. Press the button  until the purple light turns on.
6. The device will automatically turn off after approximately 6.5 minutes, but it can be stopped manually at any moment by pressing .

**Note:** the device's fan may continue to run after the process has finished.

### Accessories

#### Accessory for hot and cold milk froth

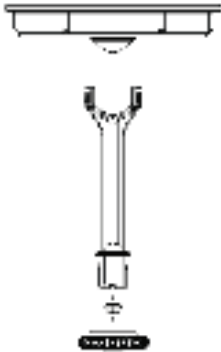



## ▶ ENGLISH

Accessory for hot milk (without spring)





Accessory for hot chocolate (with spring)



## 5. CLEANING AND MAINTENANCE

- Turn off, unplug the milk frother and allow it to cool down before cleaning or storing it.
- Remove the sealing ring from the lid for a deeper cleaning.
- Remove any accessories from inside the jug and clean them all separately.
- Never use harsh or abrasive cleaning agents or cloths/pads to clean the appliance or its accessories.
- Clean the appliance and its accessories after each use.



			
Lid	✓	✓	✓
Sealing ring	✓	✓	✓
Milk and chocolate accessories	✓	✓	✓
Jug	✓	✓	✓
Heating base	—	—	✓

## 6. TECHNICAL SPECIFICATIONS

Model: Power Moca Spume 5000

Product reference: 01518

Power: 650 W

Voltage and frequency: 220-240 V, 50/60 Hz

Made in China | Designed in Spain



## 7. DISPOSAL OF OLD ELECTRICAL APPLIANCES



The European directive 2012/19/EU on Waste Electrical and Electronic Equipment (WEEE), specifies that old household electrical appliances must not be disposed of with the normal unsorted municipal waste. Old appliances must be collected separately, in order to optimize the recovery and recycling of the materials they contain, and reduce the impact on human health and the environment.

The crossed out "wheeled bin" symbol on the product reminds you of your obligation to dispose of the appliance correctly. If the product has a built-in battery or uses batteries, they should be removed from the appliance and disposed of appropriately.

Consumers must contact their local authorities or retailer for information concerning the correct disposal of old appliances and/or their batteries.

## 8. TECHNICAL SUPPORT SERVICE AND WARRANTY

This product is under warranty for 2 years from the date of purchase, as long as the proof of purchase is submitted, the product is in perfect physical condition, and it has been given proper use, as explained in this instruction manual.

The warranty will not cover the following situations:

- The product has been used for purposes other than those intended for it, misused, beaten, exposed to moisture, immersed in liquid or corrosive substances, as well as any other fault attributable to the customer.
- The product has been disassembled, modified, or repaired by persons, not authorised by the official Technical Support Service of Cecotec.
- Faults deriving from the normal wear and tear of its parts, due to use.

The warranty service covers every manufacturing defects of your appliance for 2 years, based on current legislation, except consumable parts. In the event of misuse, the warranty will not apply. If at any moment you detect any problem with your product or have any doubt, do not hesitate to contact Cecotec Technical Support Service at **+34 96 321 07 28**.





## 2. INSTRUCTIONS DE SÉCURITÉ

Veillez lire les instructions de sécurité suivantes avec attention avant d'utiliser l'appareil. Veuillez ranger et garder ce manuel soigneusement pour de futures références ou pour tout nouvel utilisateur.

1. Assurez-vous que le voltage du réseau électrique coïncide avec le voltage spécifié sur l'étiquette de classification du produit et que la fiche possède une prise de terre.
2. Cet appareil a été conçu pour une utilisation exclusivement domestique. Ne l'utilisez pas à des fins commerciales ni industrielles.
3. Ne submergez pas le câble, la prise ni aucune autre partie du produit dans de l'eau ni dans aucun autre liquide. N'exposez pas les connexions électriques à l'eau. Assurez-vous d'avoir les mains complètement sèches avant de toucher la prise ou d'allumer l'appareil.
4. Inspectez le câble d'alimentation régulièrement en cherchant de possibles dommages visibles. Il n'existe aucune pièce à l'intérieur de l'appareil que l'utilisateur puisse réparer. Si le câble présente des dommages, il doit être réparé par le Service Après-Vente Officiel de Cecotec pour éviter tous types de dangers.
5. Nettoyez toutes les surfaces qui ont été en contact avec les aliments après chaque utilisation.
6. Les surfaces accessibles pourront atteindre des températures très élevées pendant et immédiatement après utilisation. Utilisez des gants ou autre type de protection pour éviter des brûlures.
7. Utilisez cet appareil uniquement avec la jarre et les accessoires fournis avec le produit.
8. Ne mettez pas en marche le produit sans la jarre ni avec la jarre vide.
9. Ne tordez pas, ne pliez pas, n'étirez pas ni n'abîmez le câble d'alimentation. Protégez-le des bords pointus et des sources de chaleur. Ne laissez pas le câble toucher des surfaces chaudes ni dépasser de la surface de travail ou du plan de travail.
10. Ne débranchez jamais le câble en tirant directement dessus ni avec les mains mouillées.
11. N'utilisez pas l'appareil en extérieur, dans ou sur des cuisines électriques ou fours chauds ni près du feu.
12. Ne laissez pas l'appareil fonctionner sans surveillance.
13. Ce mousser à lait est conçu pour réchauffer et faire mousser du lait et du chocolat. N'essayez pas d'épaissir ou de réchauffer d'autres aliments comme de la crème fraîche, des crèmes, des sauces, de l'eau, etc.
14. Le produit doit toujours avoir son couvercle mis lorsqu'il est en fonctionnement.
15. Ne déplacez ni ne transportez l'appareil pendant qu'il est en fonctionnement.
16. L'appareil ne doit pas être utilisé par des enfants de moins de 8 ans. Cet appareil peut être utilisé par des enfants de plus de 8 ans s'ils sont surveillés de manière continue.
17. Cet appareil peut être utilisé par des personnes aux capacités physiques, mentales ou sensorielles réduites, ou sans expérience ni connaissances si elles sont surveillées et/ou ont reçu les informations nécessaires à l'utilisation correcte de l'appareil et qu'elles ont bien compris les risques qu'il implique.
18. Surveillez les enfants pour vous assurer qu'ils ne jouent pas avec le produit. Une surveillance stricte est nécessaire si l'appareil est utilisé par ou à côté d'enfants.



## FRANÇAIS







### 3. AVANT UTILISATION

- Sortez le produit de la boîte et retirez tout le matériel qui compose l'emballage.
- Nettoyez la jarre et les accessoires comme expliqué dans le paragraphe « Nettoyage et entretien ».
- Avant de mettre le produit en marche, séchez minutieusement toutes les parties, et surtout la zone sous la base.
- Déroulez le câble d'alimentation complètement.
- Branchez le câble d'alimentation à une prise avec connexion à terre. Le témoin lumineux rouge s'allumera.

### 4. FONCTIONNEMENT

Ce mousser à lait est conçu pour faire mousser et réchauffer du lait et du chocolat. Les types de lait compatibles sont les suivants :

- Lait frais.
- Lait UHT (de vache, de brebis et de chèvre).
- Lait sans lactose.
- Lait de soja et autres alternatives



Icône	Fonction	Utilisation	Accessoire	Quantité
	Faire mousser du lait chaud.	Thick froth is perfect for cappuccino or latte macchiato.		Min. : 100 ml Max. : 200 ml
	Faire mousser du lait froid.	Cold, creamy froth is perfect for frappe drinks, cocktails, iced coffee or deserts.		Min. : 100 ml Max. : 200 ml
	Lait chaud.	This function heats up milk in a fast and easy way. Perfect for latte coffees or cups of warm milk.		Min. : 100 ml Max. : 400 ml
	Chocolat chaud.	This function prepares hot chocolate with chopped chocolate.		Min. : 100 ml Max. : 300 ml Chocolat : max. 34 g





### **Faire mousser du lait chaud**



**Note :** pour cette fonction, utilisez l'accessoire pour lait.

1. Introduisez l'accessoire pour lait dans la jarre verticalement. La base inclut un aimant qui maintiendra l'accessoire fixe.
2. Remplissez la jarre de lait et assurez-vous d'atteindre la marque MIN. sans dépasser la marque MAX.
3. Placez la jarre sur la base chauffante.
4. Fermez la jarre avec le couvercle et assurez-vous que la partie finale de l'accessoire pour lait s'emboîte correctement au couvercle. Appuyez légèrement sur le couvercle pour vous assurer qu'il soit bien fermé.
5. Appuyez sur le bouton  jusqu'à ce que le témoin lumineux rouge s'allume.
6. L'appareil s'éteindra automatiquement après 4 minutes, mais il peut aussi s'éteindre manuellement à tout moment en appuyant sur .

**Note :** une fois le processus terminé, il est possible que le ventilateur du moteur continue à fonctionner.

### **Faire mousser du lait froid**

**Note :** pour cette fonction, utilisez l'accessoire pour lait.

1. Introduisez l'accessoire pour lait dans la jarre verticalement. La base inclut un aimant qui maintiendra l'accessoire fixe.
2. Remplissez la jarre de lait et assurez-vous d'atteindre la marque MIN. sans dépasser la marque MAX.
3. Placez la jarre sur la base chauffante.
4. Fermez la jarre avec le couvercle et assurez-vous que la partie finale de l'accessoire pour lait s'emboîte correctement au couvercle. Appuyez légèrement sur le couvercle pour vous assurer qu'il soit bien fermé.
5. Appuyez sur le bouton  jusqu'à ce que le témoin lumineux bleu s'allume.
6. L'appareil s'éteindra automatiquement après 3 minutes, mais il peut aussi s'éteindre manuellement à tout moment en appuyant sur .



**Note :** une fois le processus terminé, il est possible que le ventilateur du moteur continue à fonctionner.



## FRANÇAIS

### Réchauffer du lait



**Note :** pour cette fonction, utilisez l'accessoire pour lait.

1. Introduisez l'accessoire pour lait dans la jarre verticalement. La base inclut un aimant qui maintiendra l'accessoire fixe.
2. Remplissez la jarre de lait et assurez-vous d'atteindre la marque MIN. sans dépasser la marque MAX.
3. Placez la jarre sur la base chauffante.
4. Fermez la jarre avec le couvercle et assurez-vous que la partie finale de l'accessoire pour lait s'emboîte correctement au couvercle. Appuyez légèrement sur le couvercle pour vous assurer qu'il soit bien fermé.
5. Appuyez sur le bouton  jusqu'à ce que le témoin lumineux rouge s'allume.
6. L'appareil s'éteindra automatiquement après 5 minutes, mais il peut aussi s'éteindre manuellement à tout moment en appuyant sur .

**Note :** une fois le processus terminé, il est possible que le ventilateur continue à fonctionner.

### Préparer du chocolat chaud

**Note :** pour cette fonction, utilisez les accessoires pour chocolat.

1. Introduisez l'accessoire pour lait ainsi que les accessoires pour chocolat dans la jarre verticalement. La base inclut un aimant qui maintiendra l'accessoire fixe.
2. Remplissez la jarre de lait et assurez-vous d'atteindre la marque MIN. sans dépasser la marque MAX.
3. Ajoutez le chocolat en morceaux au lait. Il est recommandé de couper le chocolat en petits morceaux pour obtenir un résultat optimal. Vous pouvez aussi utiliser du chocolat moulu ou en poudre.
4. Fermez la jarre avec le couvercle et assurez-vous que la partie finale de l'accessoire pour lait s'emboîte correctement au couvercle. Appuyez légèrement sur le couvercle pour vous assurer qu'il soit bien fermé.
5. Appuyez sur le bouton  jusqu'à ce que le témoin lumineux violet s'allume.
6. L'appareil s'éteindra automatiquement après 6.5 minutes, mais il peut aussi s'éteindre manuellement à tout moment en appuyant sur .

**Note :** une fois le processus terminé, il est possible que le ventilateur continue à fonctionner.







## Accessoires

Accessoire pour faire mousser et réchauffer du lait chaud et froid

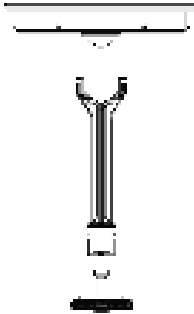

Accessoire pour réchauffer le lait (sans ressort)

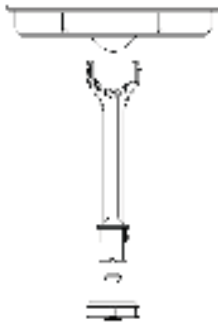

Accessoires pour chocolat chaud (à ressort)

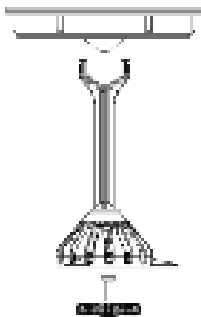





## FRANÇAIS

### 5. NETTOYAGE ET ENTRETIEN

- Éteignez le mouseur à lait, débranchez-le et laissez-le refroidir avant de le nettoyer ou de le ranger.
- Retirez l'anneau de scellage du couvercle pour un meilleur nettoyage.
- Retirez tous les accessoires présents dans la jarre et nettoyez-les séparément.
- N'utilisez pas d'éponges, de produits nettoyants en poudre ou abrasifs pour nettoyer l'appareil ainsi que ses accessoires.
- Nettoyez le mouseur à lait et les accessoires après chaque usage.

			
Couvercle	✓	✓	✓
Anneau de scellage	✓	✓	✓
Accessoires pour lait et chocolat	✓	✓	✓
Jarre	✓	✓	✓
Base chauffante	—	—	✓





## 6. SPÉCIFICATIONS TECHNIQUES

Modèle : Power Moca Spume 5000

Référence du produit : 01518

Puissance : 650 W

Voltage et fréquence : 220-240 V, 50/60 Hz

Made in China | Conçu en Espagne

## 7. RECYCLAGE DES ÉLECTROMÉNAGERS



La directive européenne 2012/19/UE relative aux Déchets d'Équipements Électriques et Électroniques (DEEE) spécifie que les électroménagers ne doivent pas être recyclés  avec le reste des déchets municipaux. Ces électroménagers doivent être jetés de manière séparée, afin d'optimiser la récupération et le recyclage des matériaux et, de cette manière, réduire l'impact qu'ils peuvent avoir sur la santé humaine et sur l'environnement.

Le symbole de la poubelle rayée vous rappelle l'obligation de vous défaire de ce produit de manière correcte. Si le produit en question possède une batterie ou une pile pour son autonomie électrique, celle-ci devra être retirée avant de jeter le produit et être traitée à part comme un résidu d'une catégorie différente.

Pour obtenir des informations détaillées sur la manière la plus adéquate de vous défaire de vos électroménagers et/ou des batteries correspondantes, vous devrez contacter les autorités locales.



## FRANÇAIS

### 8. GARANTIE ET SAV

Ce produit possède une garantie de 2 ans à partir de la date d'achat, à condition de toujours présenter la facture d'achat, que le produit soit en parfait état, et ait été utilisé correctement comme indiqué dans ce manuel d'instructions.

La garantie ne couvre pas :

- Un produit qui ait été utilisé en-dehors de ses capacités ou usages normaux, ayant subis des coups, ayant été abîmé, exposé à l'humidité, submergé dans n'importe quel liquide ou substance corrosive, ainsi que tous les incidents dont la faute serait imputable au consommateur.
- Un produit qui ait été démonté, modifié ou réparé par des personnes non autorisées par le Service Après-Vente Officiel de Cecotec.
- Lorsque le problème a été causé par l'usure normale des composants dû à l'utilisation.

Le service de garantie couvre tous les défauts de fabrication pendant 2 ans selon la législation en vigueur, à l'exception des pièces consommables. Dans le cas d'une mauvaise utilisation de la part de l'utilisateur, le service de garantie ne se fera pas responsable de la réparation. Si vous détectez un incident ou un problème avec le produit, vous devez contacter le Service Après-Vente Officiel de Cecotec au **+34 96 321 07 28**.

## 2. SICHERHEITSHINWEISE

Lesen Sie die folgenden Hinweise aufmerksam durch, bevor Sie das Gerät verwenden. Bewahren Sie die Bedienungsanleitung für künftigen Benutzer auf.

1. Vergewissern Sie sich, dass die Netzspannung mit der auf dem Typenschild des Gerätes angegebenen Spannung übereinstimmt und dass die Steckdose geerdet ist.
2. Dieses Gerät wurde nur für den Hausgebrauch entworfen. Verwenden Sie es niemals für gewerblichen, industriellen Zwecken.
3. Tauchen Sie as Kabel, Netzstecker oder andere Teile nicht ins Wasser oder anderen Flüssigkeiten. Tauchen Sie elektrische Verbindungen nicht in Wasser. Stellen Sie sicher, dass Sie Ihre Hände völlig trocknen sind, bevor Sie die Steckdose berühren oder das Gerät einschalten.
4. Überprüfen Sie das Netzkabel regelmäßig auf sichtbare Schäden. Wenn das Kabel beschädigt ist, muss es durch den offiziellen Technischen Kundendienst von Cecotec ersetzt werden, um jegliche Art von Gefahr zu vermeiden.
5. Reinigen Sie alle die Oberfläche nach jedem Gebrauch, die in Kontakt mit den Lebensmitteln waren.
6. Die zugängliche Oberfläche könnten nach dem Gebrauch sehr hohe Temperaturen erreichen. Benutzen Sie Handschuhe oder andere Arte von Schutze, um Verbrennungen zu vermeiden.
7. Verwenden Sie dieses Gerät nur mit dem Krug und mit den Zubehören des Produkts.
8. Nehmen Sie das Gerät nicht in Betrieb ohne oder mit einem leeren Krug.
9. Das Netzkabel darf nicht verdreht, verbogen oder zu stark gezogen bzw. belastet oder beschädigt werden. Schützen Sie es von scharfen Kanten und Wärmequellen. Lassen Sie niemals das Kabel mit wärmen Oberflächen Kontakt kommen. Lassen Sie das Kabel niemals über der Arbeitsfläche stehen.
10. Ziehen Sie niemals die Steckdose mit nassen Händen.
11. Verwenden Sie den Milchaufschäumer nicht im Aussen, innerhalb oder auf Kochplatten, Gaskocher oder offene Flammen.
12. Lassen Sie das Gerät niemals ohne Aufsicht.
13. Dieser Milchaufschäumer wurde entworfen, um Milch aufzuwärmen und aufzuschäumen. Versuchen Sie nicht Lebensmittel wie Sahne, Creme, Saucen, Wasser, usw.
14. Das Produkt muss beim Verwenden die Deckel haben.
15. Bewegen oder transportieren Sie beim Verwenden niemals das Gerät.
16. Das Gerät darf von Kindern unter 8 Jahren nicht benutzt werden. Es kann von Kindern ab 8 Jahren benutzt werden, sofern sie unter ständiger Beaufsichtigung während der Nutzung des Gerätes stehen.
17. Dieses Gerät darf nicht von Personen mit eingeschränkter körperlicher, sensorischer oder geistiger Leistungsfähigkeit oder fehlender Erfahrung bzw. fehlenden Kenntnissen



## DEUTSCH

verwendet werden, es sei denn, sie werden bei der Benutzung durch eine verantwortliche Person beaufsichtigt oder ihnen eine Einweisung im ordnungsgemäßen und sicheren Umgang gegeben wurde und sie die mit dem Gerät verbundenen Risiken verstanden haben und richtig einschätzen können.

18. Beaufsichtigen Sie kleine Kinder um sicher zu stellen, dass sie nicht mit dem Gerät spielen. Eine besonders genaue und konsequente Beaufsichtigung ist geboten, wenn das Gerät in der Nähe von Kindern verwendet wird.



### 3. BEVOR DEM ERSTEN GEBRAUCH

- Entnehmen Sie alle Verpackungsmaterial.
- Reinigen Sie den Milchaufschäumer und den Zubehöre wie in Abschnitt „Reinigung und Wartung“ ausgeführt.
- Bevor Sie das Gerät in Betrieb nehmen, entnehmen Sie vorsichtig alle seine Teile, besonders der Bereich unter der Basis.
- Aufwickeln Sie das Kabel völlig.
- Verbinden Sie das Stromkabel mit einer geerdeten Steckdose. Das rote Licht wird erleuchtern.

### 4. BETRIEB

Dieser Milchaufschäumer wurde entworfen, um Milch aufzuwärmen und aufzuschäumen. Vereinbare Arte von Milch:

- Frische Milch.
- Ultrahocherhitze Milch (von Kuhmilch, Schafsmilch und Ziegenmilch).
- Laktosefrei Milch.
- Sojamilch und andere.

Icon	Funktion	Verwendung	Zubehör	Menge
	Wärme Milch aufschäumen	Dicke Schaume ist ideal für Cappuccino oder Latte Macchiato.		Min.: 100 ml Max.: 200 ml
	Milchaufschäumer	Ein cremiger und kalter Milchschaum ideal für Frappés, Cocktails, Eiskaffee oder Dessert.		Min.: 100 ml Max.: 200 ml







	Heisse Milch.	Diese Funktion wärmt die Milch sehr schnell und leicht auf. Ideal für Kaffeelatte oder Gläser von heißer Milch.		Min.: 100 ml Max.: 400 ml
	Heiße Schokolade.	Diese Funktion vorbereitet heiße Schokolade mit zerkleinertem Schokolade.		Min.: 100 ml Max.: 300 ml Schokolade: max. 34 g.

**Wärme Milch aufschäumen**

**HINWEIS:** verwenden Sie den Aufsatz für Milch für diese Funktion.

1. Setzen Sie den Aufsatz für Milch vertikal. Die Basis beinhaltet einen Magnet für die richtige Halterung des Zubehörs.
2. Füllen Sie den Krug mit Milch und stellen Sie sicher, dass über der MIN-Marke ist und dass die MAX-Marke nicht übersteigt.
3. Stellen Sie den Milchaufschäumer auf der Basis.
4. Schliessen Sie den Krug mit dem Deckel und stellen Sie sicher, dass den Schluss des Aufsatzs für Milch gut gelegt ist. Drücken Sie die Deckel, bis sie völlig geschlossen ist.
5. Drücken Sie die Taste , bis das rote Licht sich erleuchtet.
6. Nach 4 Minuten wird das Gerät automatisch ausgeschaltet werden, aber Sie können es manuell beim Drücken von  ausschalten.

**HINWEIS:** Möglicherweise wird den Ventilator des Motors am Ende des Prozesses sich weiterdrehen.

**Milchaufschäumer**

**Aviso:** verwenden Sie den Aufsatz für Milch für diese Funktion.

1. Setzen Sie den Aufsatz für Milch vertikal. Die Basis beinhaltet einen Magnet für die richtige Halterung des Zubehörs.
2. Füllen Sie den Krug mit Milch und stellen Sie sicher, dass über der MIN-Marke ist und dass die MAX-Marke nicht übersteigt.
3. Stellen Sie den Milchaufschäumer auf der Basis.
4. Schliessen Sie den Krug mit dem Deckel und stellen Sie sicher, dass den Schluss des Aufsatzs für Milch gut gelegt ist. Drücken Sie die Deckel, bis sie völlig geschlossen ist.
5. Drücken Sie die Taste  bis das blaue Licht sich erleuchtet.







## **DEUTSCH**

6. Nach 3 Minuten wird das Gerät automatisch ausgeschaltet werden, aber Sie können es manuell beim Drücken von  ausschalten.
7. **HINWEIS:** Möglicherweise wird den Ventilator am Ende des Prozesses sich weiterdrehen.

### **Milch aufwärmen**



**HINWEIS:** verwenden Sie den Aufsatz für Milch für diese Funktion.

1. Stecken Sie den Aufsatz für Milch ohne den Feder aus Edelstahl vertikal im Milchaufschäumer. Die Basis beinhaltet einen Magnet für die richtige Halterung des Zubehörs.
- 2.
3. Füllen Sie den Krug mit Milch und stellen Sie sicher, dass über der MIN-Marke ist und dass die MAX-Marke nicht übersteigt.
4. Stellen Sie den Milchaufschäumer auf der Basis.
5. Schliessen Sie den Krug mit dem Deckel und stellen Sie sicher, dass den Schluss des Aufsatzs für Milch gut gelegt ist. Drücken Sie die Deckel, bis sie völlig geschlossen ist.
6. Drücken Sie die Taste  bis das rote Licht sich erleuchtet.
7. Nach 5 Minuten wird das Gerät automatisch ausgeschaltet werden, aber Sie können es manuell beim Drücken von  ausschalten.

**HINWEIS:** Möglicherweise wird den Ventilator am Ende des Prozesses sich weiterdrehen.

### **Heiße Schokolade vorbereiten**

**HINWEIS:** Verwenden Sie die Aufsätze für Schokolade für diese Funktion.

8. Stecken Sie den Aufsatz für Milch ohne den Feder aus Edelstahl vertikal im Milchaufschäumer. Die Basis beinhaltet einen Magnet für die richtige Halterung des Zubehörs.
9. Füllen Sie den Krug mit Milch und stellen Sie sicher, dass über der MIN-Marke ist und dass die MAX-Marke nicht übersteigt.
10. Stellen Sie den Milchaufschäumer auf der Basis.
11. Schliessen Sie den Krug mit dem Deckel und stellen Sie sicher, dass den Schluss des Aufsatzs für Milch gut gelegt ist. Drücken Sie die Deckel, bis sie völlig geschlossen ist.
12. Drücken Sie die Taste  bis das rote Licht sich erleuchtet.
13. 6. Nach 5 Minuten wird das Gerät automatisch ausgeschaltet werden, aber Sie können es manuell beim Drücken von  ausschalten.

**HINWEIS:** Möglicherweise wird den Ventilator am Ende des Prozesses sich weiterdrehen.







**DEUTSCH** ◀

## **Zubehöre**

Aufsatz, um kalte und warme Milch aufzuschäumen



Aufsatz, um Milch aufzuwärmen (ohne Feder)

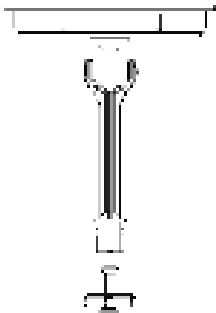

Aufsatz für heiße Schokolade (mit Feder)

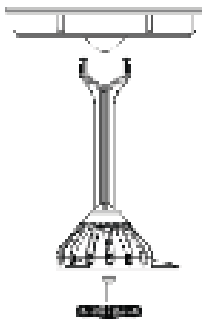





## DEUTSCH

### 5. REINIGUNG UND WARTUNG

- Schalten Sie den Milchaufschäumer aus, ziehen Sie die Steckdose und lassen Sie es abkühlen, bevor Sie lagern oder reinigen.
- Entnehmen Sie den Dichtungring für eine bessere Reinigung.
- Entnehmen Sie alle die Zubehöre von der Innenseite des Krugs und reinigen Sie sie getrennt.
- Verwenden Sie niemals Schwämme, Pulver oder Schleifmittel, um das Gerät oder seine Zubehöre zu reinigen.
- Reinigen Sie den Milchaufschäumer und die Zubehöre nach jedem Gebrauch.

			
Deckel	✓	✓	✓
Dichtungring	✓	✓	✓
Aufsatz für Milch und Schokolade	✓	✓	✓
Milchaufschäumer	✓	✓	✓
Basis	—	—	✓



## 6. TECHNISCHE SPEZIFIKATIONEN

Modell: Power Moca Spume 5000

Produktreferenz: 01518

Leistung: 650 W

Spannung und Frequenz: 220-240 V, 50/60 Hz

Hergestellt in China | Entworfen in Spanien

## 7. ENTSORGUNG VON ALTEN ELEKTROGERÄTEN



Die Europäische Richtlinie 2012/19/EU über Elektro- und Elektronik-Altgeräte (WEEE) legt fest, dass alte Haushaltsgeräte nicht mit dem normalen unsortierten Siedlungsabfall entsorgt werden dürfen. Alte Geräte müssen gesondert gesammelt werden, um die Verwertung und das Recycling der enthaltenen Materialien zu optimieren und die Auswirkungen auf die menschliche Gesundheit und die Umwelt zu reduzieren.

Das durchgestrichene Symbol "durchgestrichene Abfalltonne" auf dem Produkt erinnert Sie an Ihre Verpflichtung, das Gerät korrekt zu entsorgen. Wenn das Produkt einen eingebauten Akku hat oder Batterien verwendet, sollte der Akku oder die Batterien aus dem Gerät entnommen und separat entsorgt werden.

Die Verbraucher müssen sich mit Ihren örtlichen Behörden oder Einzelhändlern in Verbindung setzen, um Informationen über die ordnungsgemäße Entsorgung ihrer Altgeräte und/ oder ihrer Batterien zu erhalten.



## DEUTSCH

### 8. TECHNISCHER KUNDENDIENST UND GARANTIE

Dieses Produkt hat eine 2-Jahres Garantie. Die Garantiezeit beginnt mit dem Kaufdatum bzw. Lieferdatum, soweit der hierfür vorhandene und sorgfältig aufbewahrte Kaufbeleg rechtzeitig eingereicht wird, und das Produkt unter angemessener und sachgemäßer Behandlung, wie es in dieser Bedienungsanleitung beschrieben wurde, sich in einem hierfür entsprechenden, optimalen Zustand befindet.

Die Garantie deckt keine Schäden bei denen:

- Das Produkt über seine Kapazität oder Anwendbarkeit hinaus missbraucht, geschlagen, nicht ordnungsgemäß behandelt wurde oder mit ätzenden bzw. Korrosiven Substanzen oder Flüssigkeiten in Kontakt geraten ist oder die jeweilige Störung, Fehler, Schaden bzw. Defekt dem Verbraucher zugerechnet werden kann.
- Das Produkt von Personen demontiert, repariert oder modifiziert wurde, die nicht vom offiziellen Technischen Kundendienst durch Cecotec autorisiert worden sind.
- Der Grund hierfür durch die normale Abnutzung und Verschleiß der Teile und des Zubehörs entstanden ist.

Die Garantieleistung deckt alle Herstellungsbedingten Schäden und Fehler Ihres Produktes für die Dauer von 2 Jahren, nach geltendem Recht. Sollte unerwartet eine Störung auftreten oder haben Sie Fragen über Ihrem Produkt, dann können Sie sich mit der Auskunftstelle in Verbindung setzen über die Telefonnummer: **+34 963210728**.

## 2. ISTRUZIONI DI SICUREZZA

Leggere attentamente le seguenti istruzioni prima di utilizzare il prodotto. Conservare questo manuale per future consultazioni o per nuovi utenti.

1. Assicurarsi che il voltaggio della rete elettrica coincida con il voltaggio specificato sull'etichetta di classificazione del prodotto e che la presa abbia la messa a terra.
2. Questo dispositivo è stato progettato esclusivamente per un uso domestico. Non utilizzarlo per fini commerciali o industriali.
3. Non immergere il cavo, la spina, o una delle parti fisse del prodotto in acqua o in un qualsiasi altro liquido. Non esporre le connessioni elettriche all'acqua. Assicurarsi di avere le mani completamente asciutte prima di toccare la spina o di accendere il prodotto.
4. Ispezionare regolarmente il cavo di alimentazione in cerca di danni visibili. Se il cavo presentasse danni, dovrà essere riparato dal Servizio di Assistenza Tecnica ufficiale di Cecotec onde evitare qualsiasi tipo di pericolo.
5. Pulire dopo ogni utilizzo tutte le superfici che siano state a contatto con degli alimenti.
6. Le superfici accessibili potrebbero raggiungere temperature elevate durante e immediatamente dopo il funzionamento. Utilizzare guanti o qualsiasi altro tipo di protezione così da evitare ustioni.
7. Utilizzare questo apparecchio unicamente con la caraffa e con gli accessori forniti con il prodotto.
8. Non mettere in funzione l'apparecchio senza la caraffa o con la caraffa vuota.
9. Non torcere, piegare, allungare o danneggiare il cavo di alimentazione. Proteggerlo dai bordi affilati e dalle fonti di calore. Non permettere che il cavo tocchi superfici calde. Non permettere che il cavo stia sul bordo della superficie di lavoro o sul piano di lavoro.
10. Mai scollegare il cavo di alimentazione tirando dal cavo o con le mani bagnate.
11. Non utilizzare il prodotto in esterni, dentro o sopra fornelli elettrici, forni caldi o vicino al fuoco.
12. Non lasciare l'apparecchio in funzione senza sorveglianza.
13. Questo prodotto è stato progettato per scaldare e montare latte o cioccolata. Non provare a inspessire o scaldare altri alimenti come panna, crema, salse, acqua, ecc.
14. Il prodotto deve sempre tenere il coperchio posto quando è in funzione.
15. Non muovere né spostare l'apparecchio mentre è in funzione.
16. L'apparecchio non deve essere usato da bambini di età compresa tra 0 e 8 anni. Questo elettrodomestico può essere usato da bambini di 8 anni e maggiori agli 8 anni di età, solo se continuamente sorvegliati.
17. Questo prodotto può essere utilizzato da persone con capacità fisiche, sensoriali o mentali ridotte, o con mancanza di esperienza e conoscenza, solo sotto supervisione o se hanno ricevuto informazioni concernenti un utilizzo sicuro dell'apparecchio, capendo i rischi che questo implica.
18. Vigilare i bambini per assicurarsi che non giochino con il prodotto. È necessaria una sorveglianza continua se il prodotto è in uso vicino a dei bambini, o da loro stessi usato.









## ▶ ITALIANO

### 3. PRIMA DELL'USO

- Estrarre il prodotto dalla scatola e togliere tutto il materiale dall'imballaggio.
- Pulire la caraffa e gli accessori come indicato nella sezione "Pulizia e manutenzione".
- Prima di mettere il prodotto in funzione, asciugare minuziosamente tutte le sue parti, in particolare la zona sotto la base.
- Srotolare completamente il cavo.
- Connettere il cavo di alimentazione a una presa con messa a terra, la luce rossa si accenderà.

### 4. FUNZIONAMENTO

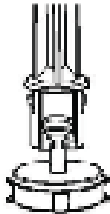
- Questo montalatte è stato progettato per montare e scaldare latte e cioccolato. I tipi di latte compatibili sono i seguenti:
- Latte fresco.
- Latte UHT (di mucca, pecora e capra).
- Latte senza lattosio.
- Latte di soia e altre alternative.

Icona	Funzione	Uso	Accessorio	Quantità
	Montare latte caldo.	Una schiuma spessa è perfetta per il cappuccino o per il latte macchiato.		Min.: 100 ml Max.: 200 ml
	Montare latte freddo.	Una schiuma cremosa e fredda è perfetta per frappé, cocktails, caffè shakerato o dolci.		Min.: 100 ml Max.: 200 ml
	Latte caldo.	Questa funzione scalda il latte in modo facile e veloce. È perfetta per del caffè latte o delle tazze di latte caldo.		Min.: 100 ml Max.: 400 ml
	Cioccolata calda.	Esta función prepara chocolate caliente con chocolate troceado.		Min.: 100 ml Máx.: 300 ml Chocolate: máx. 34 g





### **Montare latte caldo**



**Avviso:** per questa funzione utilizzare l'accessorio per il latte.

1. Introdurre in verticale l'accessorio per il latte nella caraffa. La base dispone di un magnete che manterrà l'accessorio fermo.
2. Riempire la caraffa con del latte e assicurarsi che il livello sia al di sopra del segno MIN. e che non superi il segno MAX.
3. Collocare la caraffa sulla base riscaldante.
4. Chiudere la caraffa con il coperchio e assicurarsi che la parte finale dell'accessorio per il latte s'incastri correttamente nel coperchio. Premere leggermente il coperchio fino ad assicurarsi che sia totalmente chiuso.
5. Premere il tasto  fino a che si accenda la luce rossa.
6. L'apparecchio si spegnerà in modo automatico dopo circa 4 minuti, tuttavia è possibile spegnerlo manualmente in qualsiasi momento premendo

**Avviso:** è possibile che la ventola del motore resti in funzione una volta terminato il processo.

### **Montare latte freddo**

**Avviso:** per questa funzione utilizzare l'accessorio per il latte.

1. Introdurre in verticale l'accessorio per il latte nella caraffa. La base dispone di un magnete che manterrà l'accessorio fermo.
2. Riempire la caraffa con del latte e assicurarsi che il livello sia al di sopra del segno MIN. e che non superi il segno MAX.
3. Collocare la caraffa sulla base riscaldante.
4. Chiudere la caraffa con il coperchio e assicurarsi che la parte finale dell'accessorio per il latte s'incastri correttamente nel coperchio. Premere leggermente il coperchio fino ad assicurarsi che sia totalmente chiuso.
5. Premere il tasto  fino a che si accenda la luce blu.
6. L'apparecchio si spegnerà in modo automatico dopo circa 3 minuti, tuttavia è possibile spegnerlo manualmente in qualsiasi momento premendo .



**Avviso:** è possibile che la ventola del motore resti in funzione una volta terminato il processo.



## ITALIANO

### Scaldare latte



**Avviso:** per questa funzione utilizzare l'accessorio per il latte.

1. Introdurre verticalmente nella caraffa l'accessorio per il latte senza molla in acciaio inossidabile. La base dispone di un magnete che manterrà l'accessorio fermo.
2. Riempire la caraffa con del latte e assicurarsi che il livello sia al di sopra del segno MIN. e che non superi il segno MAX.
3. Collocare la caraffa sulla base riscaldante.
4. Chiudere la caraffa con il coperchio e assicurarsi che la parte finale dell'accessorio per il latte s'incastri correttamente nel coperchio. Premere leggermente il coperchio fino ad assicurarsi che sia totalmente chiuso.
5. Premere il tasto  fino a che si accenda la luce rossa.
6. L'apparecchio si spegnerà in modo automatico dopo circa 5 minuti, tuttavia è possibile spegnerlo manualmente in qualsiasi momento premendo .

**Avviso:** è possibile che la ventola del motore resti in funzione una volta terminato il processo.

### Preparare cioccolata calda

**Avviso:** per questa funzione utilizzare l'accessorio per il cioccolato.

1. Introdurre in verticale gli accessori per il cioccolato e per il latte nella caraffa. La base dispone di un magnete che manterrà l'accessorio fermo.
2. Riempire la caraffa con del latte e assicurarsi che il livello sia al di sopra del segno MIN. e che non superi il segno MAX.
3. Aggiungere al latte del cioccolato a pezzi. Si raccomanda di tagliare pezzi piccoli per ottenere un risultato ottimale. È possibile anche utilizzare del cioccolato macinato o in polvere.
4. Chiudere la caraffa con il coperchio e assicurarsi che la parte finale degli accessori per il cioccolato e per il latte s'incastri correttamente nel coperchio. Premere leggermente il coperchio fino ad assicurarsi che sia totalmente chiuso.
5. Premere il tasto  fino a che si accenda la luce viola.
6. L'apparecchio si spegnerà in modo automatico dopo circa 6 minuti e mezzo, tuttavia è possibile spegnerlo manualmente in qualsiasi momento premendo .

**Avviso:** è possibile che la ventola del motore resti in funzione una volta terminato il processo.







**ITALIANO** ◀

## **Accessori**

Accessori per montare latte caldo o freddo



Accessorio per il latte caldo (senza molla)

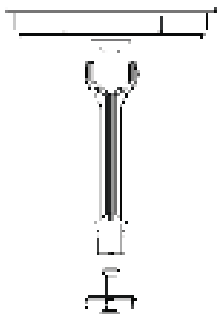

Accessorio per la cioccolata calda (con molla)

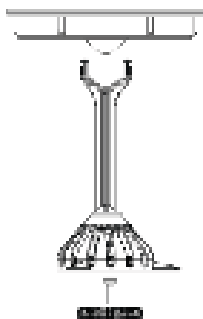





## ▶ ITALIANO

### 5. PULIZIA E MANUTENZIONE

- Spegnere il montalatte, scollegarlo e lasciare che si raffreddi prima di procedere alla pulizia o all'immagazzinamento.
- Togliere l'anello di sigillo del coperchio per una migliore pulizia.
- Togliere tutti gli accessori da dentro la caraffa e pulirli separatamente.
- Non utilizzare spugne, detersivi in polvere o prodotti di pulizia abrasivi per pulire l'apparecchio e gli accessori.
- Pulire il montalatte e gli accessori dopo ogni uso.

			
Coperchio	✓	✓	✓
Anello di sigillo	✓	✓	✓
Accessori per il latte e il cioccolato	✓	✓	✓
Caraffa	✓	✓	✓
Base riscaldante	—	—	✓



## 6. SPECIFICHE TECNICHE

Model: Power Moca Spume 5000

Referenza del prodotto: 01518

Potenza: 650 W

Voltaggio e frequenza: 220-240 V, 50/60 Hz

Made in China | Progettato in Spagna

## 7. RICICLAGGIO DEGLI ELETTRODOMESTICI



La direttiva europea 2012/19/UE circa i Residui degli Apparecchi Elettrici e Elettronici (RAEE), specifica che gli elettrodomestici non devono essere riciclati con il resto dei rifiuti. Questi devono essere gettati separatamente, per ottimizzare il recupero e il riciclo dei materiali e, in questo modo, ridurre l'impatto che possano avere sulla salute umana e sull'ambiente.

Il simbolo del contenitore crocettato le ricorda i suoi obblighi di liberarsi di questi prodotti in modo corretto. Se il prodotto in questione è dotato di batteria o pila per l'autonomia elettrica, questa deve essere estratta, prima di gettarlo, ed essere eliminata separatamente, come un rifiuto di diversa categoria.

Per ottenere informazioni dettagliate circa il modo più adeguato di eliminare i suoi elettrodomestici e/o le batterie corrispondenti, il consumatore dovrà contattare le autorità locali.

## 8. GARANZIA E SAT

Questo prodotto ha una garanzia di 2 anni a decorrere dalla data d'acquisto, sempre se si conserva per l'invio la fattura d'acquisto, se il prodotto è in buono stato fisico e se ne è stato fatto un uso adeguato, come indicato in questo manuale d'istruzioni.

La garanzia non coprirà:

- Se il prodotto è stato usato fuori dalle sue capacità e utilità, maltrattato, colpito, esposto all'umidità, immerso in qualche liquido o sostanza corrosiva, così come per qualsiasi altro errore attribuibile al consumatore.
- Se il prodotto è stato smontato, modificato o riparato da persone non autorizzate dal SAT ufficiale di Cecotec.
- Se il problema è causato dalla normale usura dei pezzi dovuta all'uso.

Il servizio di garanzia copre tutti i difetti di fabbricazione durante 2 anni in base alla legislazione vigente, eccetto per i pezzi sottoposti a usura. In caso di mal utilizzo da parte dell'utente il servizio di garanzia non sarà responsabile della riparazione. Qualora si riscontrassero anomalie nel prodotto, oppure se si desiderasse ottenere delle informazioni, occorre contattare il Servizio di Assistenza Tecnica di Cecotec al seguente numero di telefono: **+34 96 321 07 28**.



## **PORTUGUÊS**

### **2. INSTRUÇÕES DE SEGURANÇA**

Leia as seguintes instruções atentamente antes de usar o produto. Guarde este manual para referências futuras ou novos usuários.

1. Certifique-se de que a voltagem de rede coincida com a voltagem especificada na etiqueta de classificação do produto e que a tomada tenha corrente.
2. Este dispositivo está desenhado só para o uso doméstico. Não utilize para fins comerciais ou industriais.
3. Não submerja o cabo, a tomada ou qualquer outra parte do produto em água ou qualquer outro líquido. Não exponha as conexões elétricas à água. Certifique-se de que tem as mãos completamente secas antes de tocar na tomada ou ligar o produto.
4. Inspeção o cabo de alimentação regularmente em busca de danos visíveis. Não há nenhum tipo de peça no interior do aparelho que o utilizador possa reparar. Se o cabo apresenta danos, deve ser reparado pelo Serviço de Assistência Técnica oficial de Cecotec para evitar qualquer tipo de perigo.
5. Limpe todas as superfícies que tenham estado em contacto com alimentos depois de cada uso.
6. As superfícies acessíveis poderão alcançar temperaturas muito elevadas durante e imediatamente depois de funcionar. Utilize luvas ou qualquer outro tipo de proteção para evitar queimaduras.
7. Utilize este produto unicamente com a jarra e os acessórios que se proporcionam com o produto.
8. Não ponha em funcionamento o aparelho sem a jarra ou com a jarra vazia.
9. Não torça, dobre, estique ou danifique o cabo de alimentação. Proteja de bordas afiadas e fontes de calor. Não permita que o cabo toque superfícies quentes. Não deixe que o cabo se aproxime da superfície de funcionamento do aparelho.
10. Nunca desligue o cabo de alimentação puxando pelo cabo nem com as mãos molhadas.
11. Não utilize o produto no exterior, perto de placas elétricas ou de gás, de chamas ou dentro de fornos.
12. Não deixe o produto em funcionamento sem supervisão.
13. Este espumador está desenhado para aquecer e espumar leite ou chocolate. Não tente espessar ou aquecer outros alimentos como natas, molhos, água, etc.
14. O produto deve ter a tampa posta sempre que estiver em funcionamento.
15. Não mova nem transporte o aparato enquanto estiver em funcionamento.
16. O aparelho não deve ser usado por crianças desde 0 até 8 anos. Este eletrodoméstico pode ser usado por crianças a partir de 8 anos de idade se estão continuamente sob supervisão.
17. Este produto pode ser usado por pessoas com capacidades físicas, sensoriais ou mentais reduzidas ou com falta de experiência se estiverem sob supervisão ou tenham recebido





instruções concernentes ao uso do aparelho de forma segura e entendem os riscos que este implica.



18. Supervisione as crianças para assegurar que não brinquem com o produto. É necessário dar uma supervisão estrita se o produto estiver em uso perto de crianças.

### 3. ANTES DE USAR

- Tire o produto da caixa e retire todo o material da embalagem.
- Limpe a jarra e os acessórios como se explica na secção de "Limpeza e manutenção".
- Antes de por o produto em funcionamento, seque minuciosamente todas as partes, em especial a zona de debaixo da base.
- Desenrole completamente o cabo.
- Conecte o cabo de alimentação a uma tomada com toma de terra, a luz vermelha acenderá.



### 4. FUNCIONAMENTO

- Este espumador está desenhado para espumar e aquecer leite e chocolate. Os tipos de leite compatíveis são os seguintes:
- Leite fresco.
- Leite UHT (de vaca, ovelha e cabra).
- Leite sem lactose.
- Leite de soja e outras alternativas.

Ícone	Função	Uso	Acessório	Quantidade
	Espumar leite quente.	A espuma grossa é perfeita para o cappuccino ou latte macchiato.		Min.: 100 ml Max.: 200 ml
	Espumar leite frio.	A espuma cremosa e fria é perfeita para frappés, cocktails, café gelado ou sobremesas.		Min.: 100 ml Max.: 200 ml



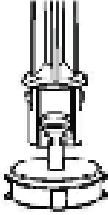

## **PORTUGUÊS**

	Leite quente.	Esta função aquece o leite de maneira muito fácil e rápida. É perfeita para café latte ou copos de leite quente.		Min.: 100 ml Max.: 400 ml
	Chocolate quente.	Esta função prepara chocolate quente com chocolate triturado.		Min.: 100 ml Max.: 300 ml Chocolate: Max. 34 g

### **Espumar leite quente**

**Aviso:** para esta função utilize o acessório para leite.

1. Introduza o acessório para leite a jarra de forma vertical. A base inclui um ímã que mantém o acessório preso.
2. Encha a jarra de leite e certifique-se de que está por cima da marca de MIN. e não excede a marca de MAX.
3. Coloque a jarra sobre a base aquecedora.
4. Feche a jarra com a tampa e certifique-se de que a parte final do acessório para leite encaixe corretamente na tampa. Aperte ligeiramente a tampa até verificar de que está totalmente fechada.
5. Pressione o botão  até que se acenda a luz vermelha.
6. O aparelho se apagará de forma automática aos 4 minutos, mas também pode apagar manualmente em qualquer momento ao pressionar .

**Aviso:** é possível que o ventilador continue a funcionar depois de ter acabado o processo.

### **Espumar leite frio**

**Aviso:** para esta função utilize o acessório para leite.

1. Introduza o acessório para leite na jarra de forma vertical. A base inclui um ímã que mantém o acessório preso.
2. Encha a jarra de leite e certifique-se de que está por cima da marca de MIN. e não excede a marca de MAX.
3. Coloque a jarra sobre a base aquecedora.
4. Feche a jarra com a tampa e certifique-se de que a parte final do acessório para leite encaixe corretamente na tampa. Aperte ligeiramente a tampa até garantir de que está totalmente fechada.
5. Pressione o botão  até que se acenda a luz azul.







6. O aparelho se apagará de forma automática aos 3 minutos, mas também pode desligar-se manualmente em qualquer momento ao pressionar .

**Aviso:** é possível que o ventilador continue a funcionar depois de ter acabado o processo.

### **Aquecer leite**



**Aviso:** para esta função utilize o acessório para leite.

1. Introduza o acessório para leite sem a mola de aço inoxidável na jarra de forma vertical. A base inclui um íman que mantém o acessório preso.
2. Encha a jarra de leite e certifique-se de que está por cima da marca de MIN. e não excede a marca de MAX.
3. Coloque a jarra sobre a base aquecedora.
4. Feche a jarra com a tampa e certifique-se de que a parte final do acessório para leite encaixa corretamente na tampa. Aperte ligeiramente a tampa até garantir que está totalmente fechada.
5. Pressione o botão  até que se acenda a luz vermelha.
6. O aparelho se apagará de forma automática aos 3 minutos, mas também pode desligar-se manualmente em qualquer momento ao pressionar .

**Aviso:** é possível que o ventilador continue a funcionar depois de ter acabado o processo

### **Preparar chocolate quente**

**Aviso:** para esta função utilize os acessórios para chocolate.

1. Introduza o acessório para leite com os acessórios de chocolate na jarra de forma vertical. A base inclui um íman que mantém o acessório preso.
2. Encha a jarra de leite e certifique-se de que está por cima da marca de MIN. e não excede a marca de MAX.
3. Adicione chocolate triturado ao leite. É recomendável cortar pedaços pequenos para obter um resultado ótimo. Também se pode utilizar chocolate moído ou em pó.
4. Feche a jarra com a tampa e certifique-se de que a parte final do acessório para leite encaixe corretamente na tampa. Aperte ligeiramente a tampa até garantir que está totalmente fechada.
5. Pressione o botão  até que se acenda a luz lilás.
6. O aparelho se apagará de forma automática aos 6.5 minutos, mas também se pode apagar manualmente em qualquer momento ao pressionar .

**Aviso:** é possível que o ventilador continue a funcionar depois de ter acabado o processo.





## ▶ PORTUGUÊS

### Acessórios

Acessórios para espumar leite quente e frio



Acessório para leite quente (sem mola)

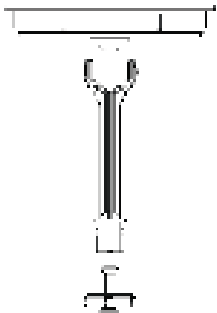

Accesorios para chocolate caliente (con muelle)

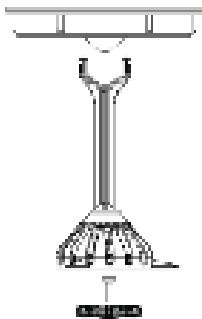







## 5. LIMPEZA E MANUTENÇÃO

- Desligue o espumador, desconecte da corrente elétrica e permita que se arrefeça antes de proceder à limpeza ou a guardar.
- Retire a argola de selado da tampa para uma melhor limpeza.
- Retire todos os acessórios de dentro da jarra e limpe por separado.
- Não utilize esponjas, pós ou produtos de limpeza abrasivos para limpar tanto o produto como os seus acessórios.
- Limpe o espumador e os acessórios depois de cada uso.

			
Tampa	✓	✓	✓
Argola de selado	✓	✓	✓
Acessórios para leite e chocolate	✓	✓	✓
Jarra	✓	✓	✓
Base elétrica	—	—	✓



## **PORTUGUÊS**

### **6. ESPECIFICAÇÕES TÉCNICAS**

Modelo: Power Moca Spume 5000

Referência do produto: 01518

Potência: 650 W

Voltagem e frequência: 220-240 V, 50/60 Hz

Feito na China | Desenhado em Espanha

### **7. RECICLAGEM DE ELETRODOMÉSTICOS**



A diretiva europeia 2012/19/UE sobre Resíduos de Aparelhos Elétricos e Eletrônicos (RAEE) especifica que os eletrodomésticos não devem ser reciclados com o resto dos resíduos municipais. Ditos eletrodomésticos devem ser descartados de forma separada, para otimizar a recuperação e reciclagem de materiais e, de esta maneira, reduzir o impacto que possam ter na saúde humana e meio ambiente.

O símbolo de contentor riscado recorda a sua obrigação de descartar este produto de forma correta. Se o produto em questão conta com uma bateria ou pilha para a sua autonomia elétrica, esta deverá extrair-se antes de ser descartada e ser tratada como um resíduo de diferente categoria. Para obter informação detalhada acerca da forma mais adequada de descartar os seus eletrodomésticos e/ou as correspondentes baterias, o consumidor deverá contactar com as autoridades locais.

### **8. GARANTIA E SAT**

Este produto tem uma garantia de 2 anos desde a data de compra, sempre e quando se conserve e envie a fatura de compra, o produto está em perfeito estado físico e se dê uso adequado tal e como se indica neste manual de instruções.

A garantia não cobrirá:

- Se o produto foi usado fora da sua capacidade ou utilidade, maltratado, batido, exposto a humidade, submergido em algum líquido ou substância corrosiva, assim como qualquer outra falta atribuível ao consumidor.
- Se o produto foi desmontado, modificado ou reparado por pessoas não autorizadas pelo SAT oficial de Cecotec.
- Se a origem da incidência foi pelo desgaste normal das peças devido ao uso.

O serviço de garantia cobre todos los defeitos de fabricação durante 2 anos com base na legislação vigente, exceto peças consumíveis. Em caso de mau uso por parte do usuário o serviço de garantia não se fará responsável da reparação.

Se deteta uma ocorrência com o produto ou tem alguma consulta, entre em contacto com o Serviço de Assistência Técnica oficial de Cecotec através do número de telefone **+34 96 321 07 28**.







[www.cecotec.es](http://www.cecotec.es)

Grupo Cecotec Innovaciones S. L.  
C/de la Pinadeta s/n, 46930  
Quart de Poblet, Valencia, Spain

