

**F** -ATTENTION!  
**GB** -WARNING!  
**D** -ACHTUNG!  
**NL** -WAARSCHUWING!  
**E** -ADVERTENCIA!  
**P** -ATENÇÃO!  
**I** -AVVERTENZA!  
**DK** -ADVARSEL!  
**S** -VARNING!  
**FIN** -VAROITUS!  
**N** -ADVARSEL!  
**H** -FIGYELMEZTETÉS!  
**CZ** -UPOZORNĚNÍ!  
**SK** -UPOZORNENIE!

**PL** - OSTRZEŻENIE!  
**BG** -ВНИМАНИЕ!  
**RO** -AVERTISMENT!  
**GR** -ΠΡΟΕΙΔΟΠΟΙΗΣΗ!  
**SI** -OPOZORILO!  
**HRV** -UPOZORENJE!  
**TR** -UYARI!  
**RUS** -ВНИМАНИЕ!  
**UA** -УВАГА!  
**EST** -HOIATUS!  
**LT** -DĖMESIO!  
**LV** -UZMANĪBU!  
**AR** -تنبيه!

**★+2**

ans  
 years  
 Jahre  
 jaar  
 años  
 anos  
 anni  
 år  
 år  
 vuotta  
 är  
 év  
 let  
 rokov  
 lata  
 години  
 ani  
 ani  
 χρόνια  
 سنوات

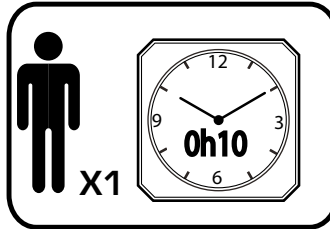

**Smoby**

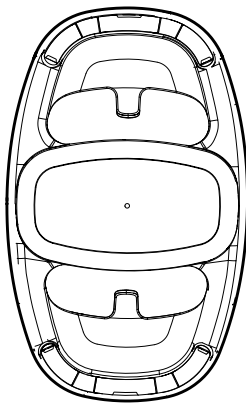
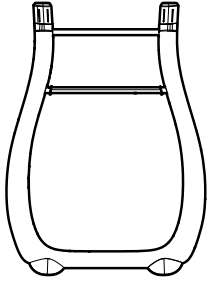
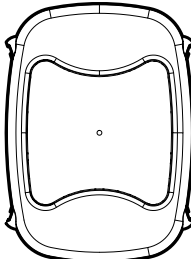
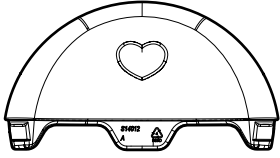
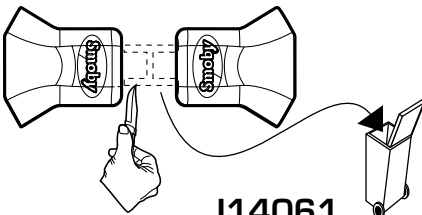
<p><b>A</b></p>  <p>I14060</p>	<p>x1</p>	<p><b>C</b></p>  <p>OUT3488</p>	<p>x2</p>
<p><b>B</b></p>  <p>I14062</p>	<p>x1</p>	<p><b>D</b></p>  <p>S14012</p>	<p>x2</p>
		<p><b>E</b></p>  <p>I14061</p>	<p>x1</p>

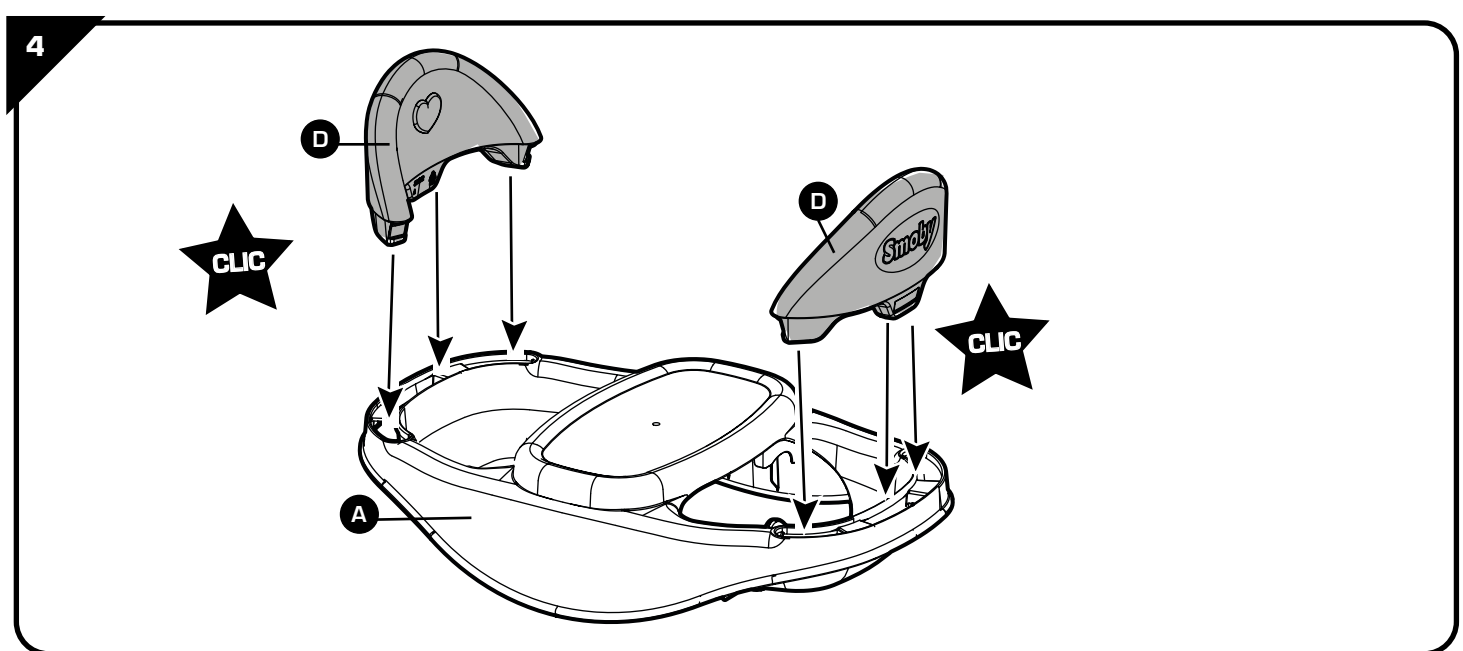
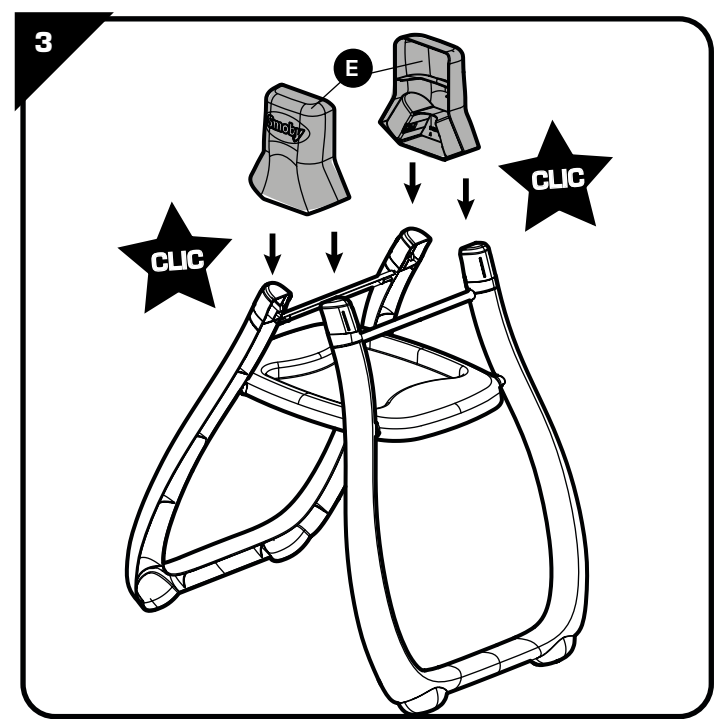
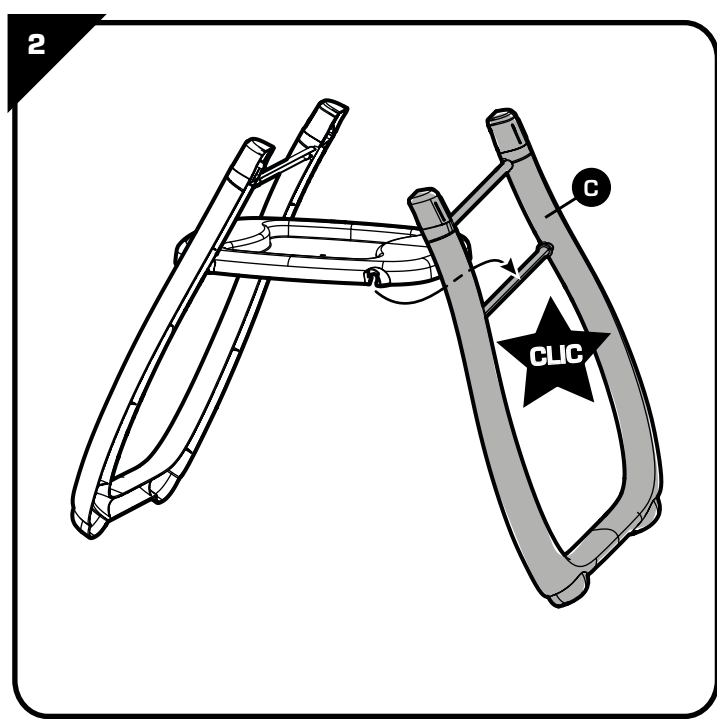
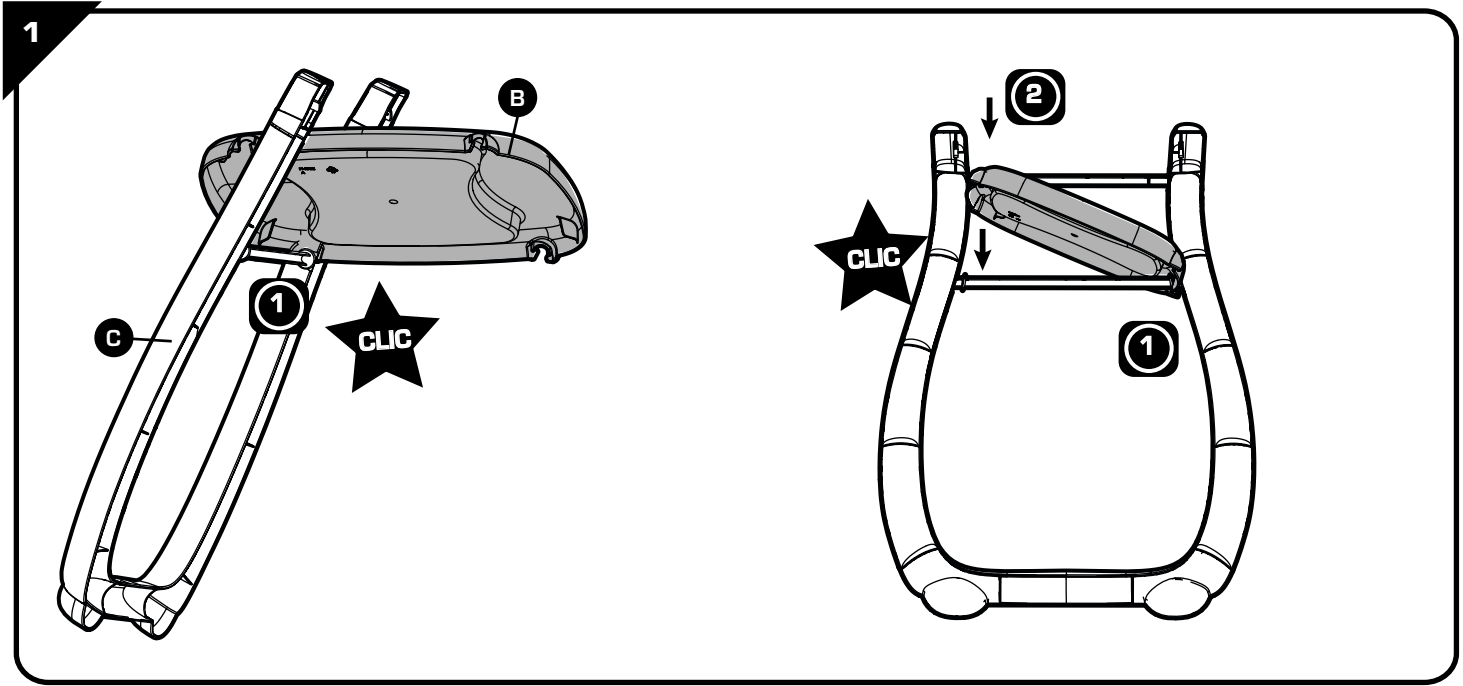

5

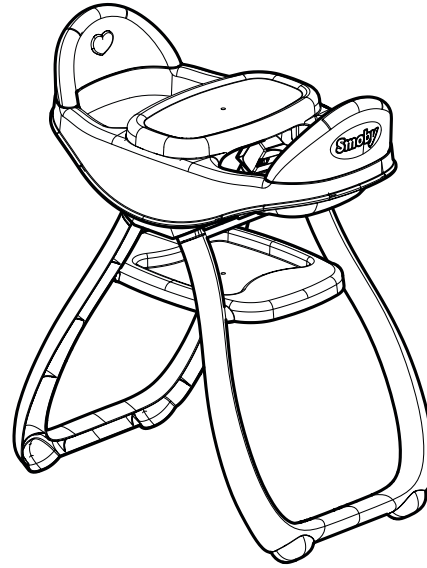
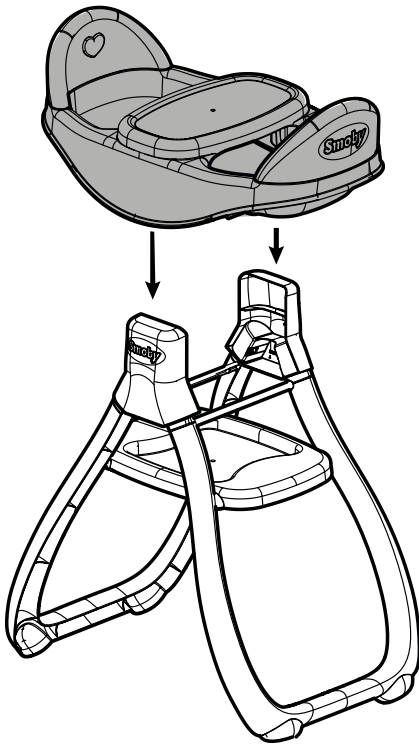

Chaise haute jumeaux

**SMOBY TOYS S.A.S.**

**Service après vente / After sales service : [www.smoby.fr](http://www.smoby.fr)  
95 route du Haut Jura - 39170 Lavans-lès-Saint-Claude / France.**

**Assistance consommateurs à nous retourner en cas de problèmes** / Consumer assistance: for any problems, return this card /  
Verbraucher-Info: Für weitere Auskünfte, senden Sie diese Karte bitte an / Klantenservice : voor inlichtingen, deze kaart naar ons terugsturen /  
Atención al consumidor : para cualquier información, enviar esta tarjeta. / Assistenza per il consumatore : per informazioni, rispedire la presente cartolina.

NOM / NAME : \_\_\_\_\_

PRENOM / SURNAME : \_\_\_\_\_

RUE / STREET : \_\_\_\_\_

VILLE / TOWN : \_\_\_\_\_

CODE POSTAL / POSTAL CODE : \_\_\_\_\_

PAYS / COUNTRY : \_\_\_\_\_

N°TEL : \_\_\_\_\_

EMAIL : \_\_\_\_\_

**Description du motif de la réclamation** / Cause for complaint / Grund der Beanstandung /  
Omschrijving van de reden van de klacht / Detalle el motivo de su reclamación / Descizione del  
motivo del reclamo :

 **Manquant** / Missing / Fehlende Teile / Tekort / Faltante / Mancante.

 **Cassé** / Broken / Gebrochen / Gebroken / Rotura / Rotto.

 **Commentaires** / Comments / Bemerkung / Opmerkingen  
/ Comentarios / Commenti.

Ref.: \_\_\_\_\_

Couleurs/Colors: \_\_\_\_\_

N° Notice / IS Number :

**AAP1577B**N°: N°: N°: N°: N°: N°: N°: 

Qté: .....

Qté: .....

Qté: .....

Qté: .....

Qté: .....

Qté: .....

Qté: .....



**⚠ WARNING:**

Never allow a child to play without adult supervision.

**⚠ WARNING:**

Toy must be assembled by an adult, as it contains hazardous points or edges. A sharp tool shall be used

