



# LOGICO

9636000

cm 65x45x182 h

- I Istruzioni per il montaggio
- GB Assembly instruction
- D Montageanleitungen
- F Instructions pour le montage
- E Instrucción para el montaje
- NL Instructies voor de montage

- TR Montaj talimatları
- GR Οδηγίες συναρμολόγησης
- RUS Инструкции за монтаж
- RO Instrucțiuni de montaj
- CZ Návod na montáž
- PL Instrukcja montażu

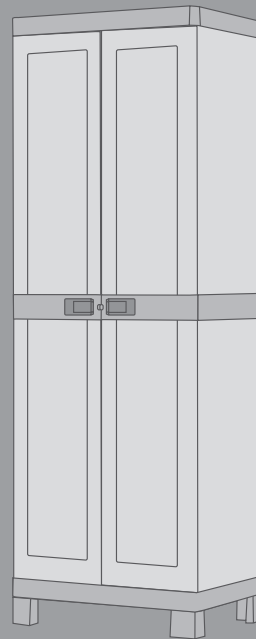

\* Distribuiti uniformemente - Equally distributed - Gleichmässig verteilt - Distribué uniformement - Uniformemente distribuido - Op gelijkmatige wijze verdeeld - Ağırlık eşit olarak dağıtılmalıdır - Κατανεμημένο ομοιόμορφα - Равномерно распределенная - Distribuite in mod egal - Rovnoměrně rozložení - Jednolicie rozložone obciążenie

[www.kis.it](http://www.kis.it)

MADE IN  
ITALY

290473\_Rev.01\_06/14

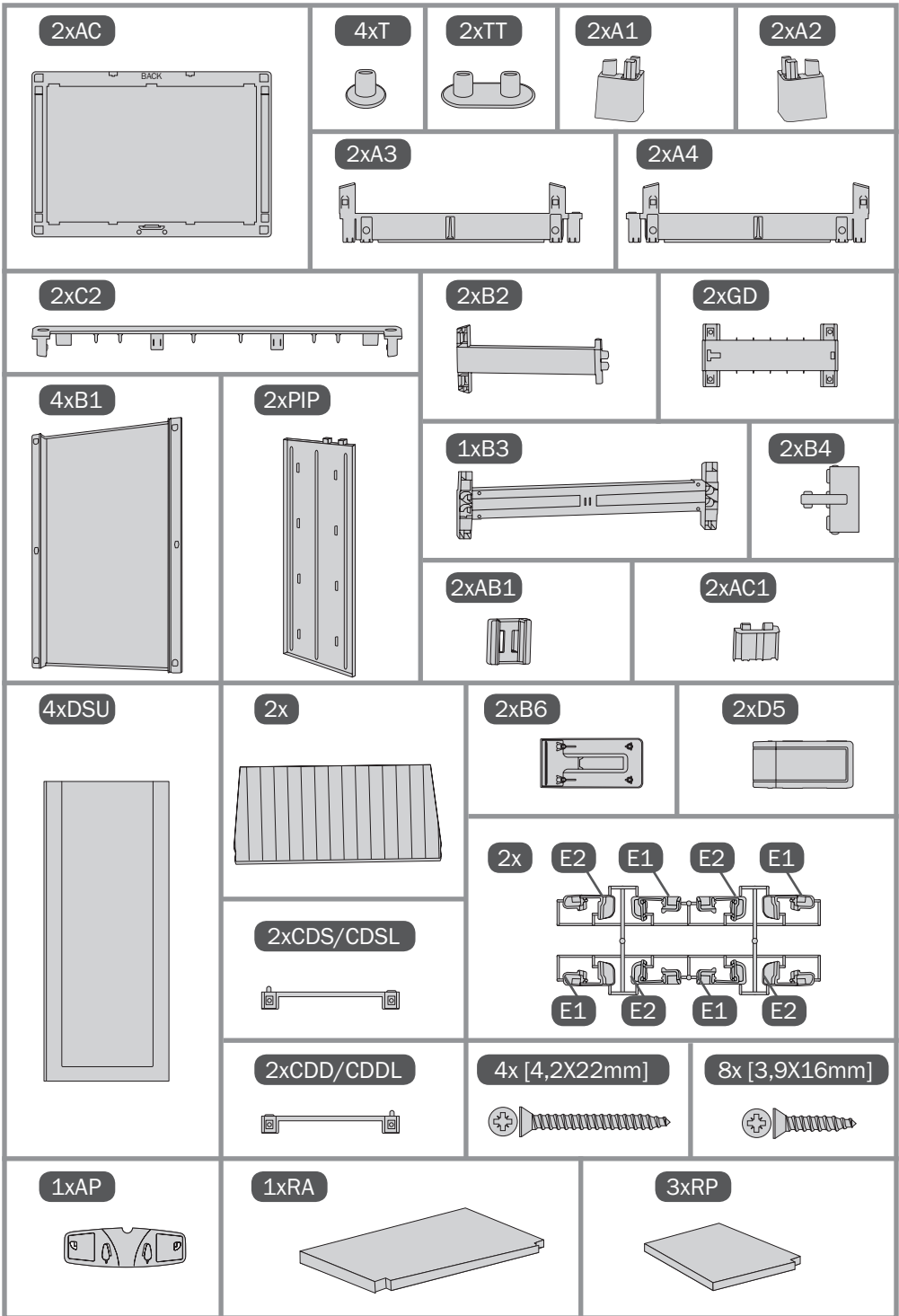



- I** Conservare il manuale d'uso per referenze future in prossimità del prodotto. Prima di iniziare l'assemblaggio leggere attentamente le avvertenze.
- GB** Keep this instruction manual with the product for future reference. Read the instructions carefully before assembly. **D** Bewahren Sie das Benutzerhandbuch in der Nähe des Produkts auf, damit Sie später jederzeit nachschlagen können. Lesen Sie vor der Montage die Anweisungen aufmerksam durch. **F** Conserver le manuel d'utilisation à proximité du produit pour de futures références. Lire attentivement la notice avant de commencer l'assemblage. **E** Guarde el manual de uso para futuras consultas cerca del producto. Antes de empezar el montaje, lea detenidamente las advertencias. **NL** Bewaar de handleiding in nabijheid van het product voor toekomstige raadpleging. Lees deze voorschriften aandachtig alvorens met de montage te beginnen. **TR** Kullanıcı el kitabını ürüne yakın bir yerde saklayın. Montajı başlamanın önce etiketleri dikkatle okuyun. **GR** Φυλάξτε αυτό το εγχειρίδιο χρήσης κοντά στο προϊόν για μελλοντικές χρήσεις. Πριν ξεκινήσετε την συναρμολόγηση διαβάστε προσεκτικά τις προειδοποιήσεις ασφαλείας. **RUS** Храните руководство пользователя поблизости от изделия для дальнейшего к нему обращения. Перед тем, как приступить к сборке, внимательно ознакомьтесь с предупреждениями. **RO** Păstrați manualul de utilizare în apropierea produsului pentru consultări ulterioare. Înainte de a începe asamblarea citiți cu atenție avertismentele. **CZ** Uchovejte tento návod pro jeho případné další použití. Před montáží si pečlivě přečtěte instrukce. **PL** Przechowywać instrukcję obsługi w pobliżu produktu do przyszłych konsultacji. Przed rozpoczęciem montażu przeczytać uważnie pouczenia.

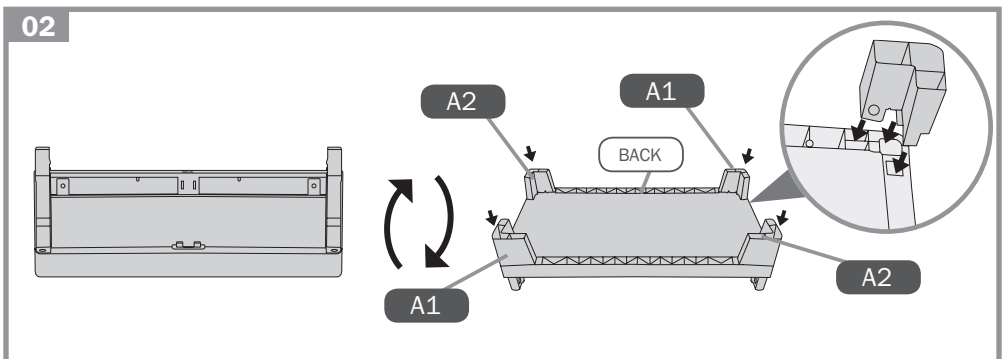
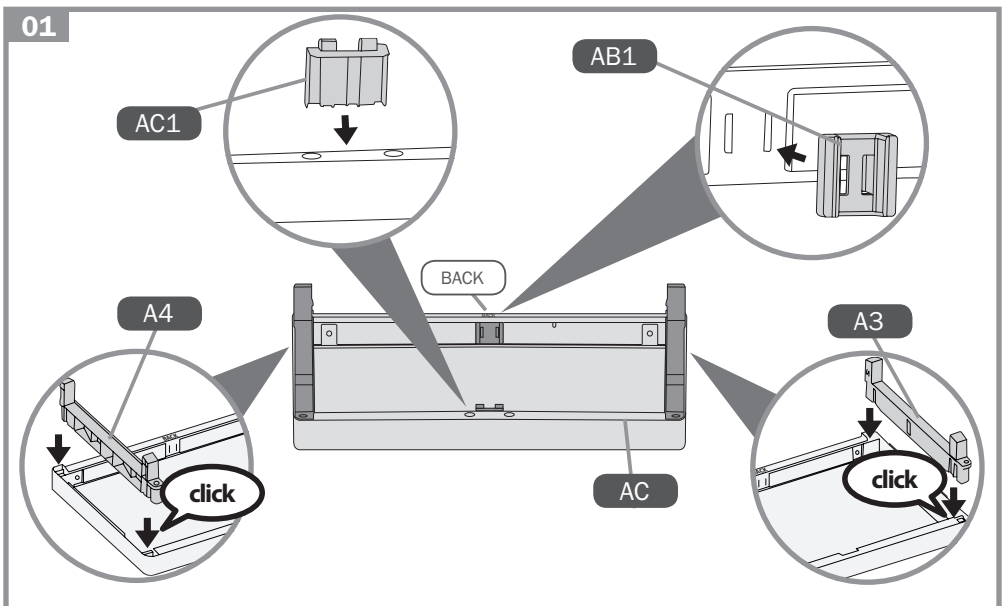

03

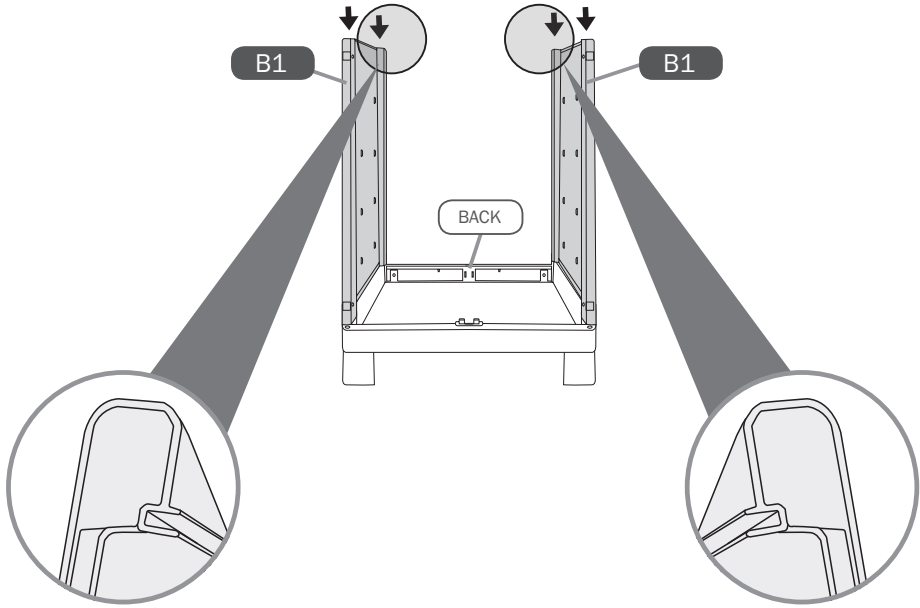

04

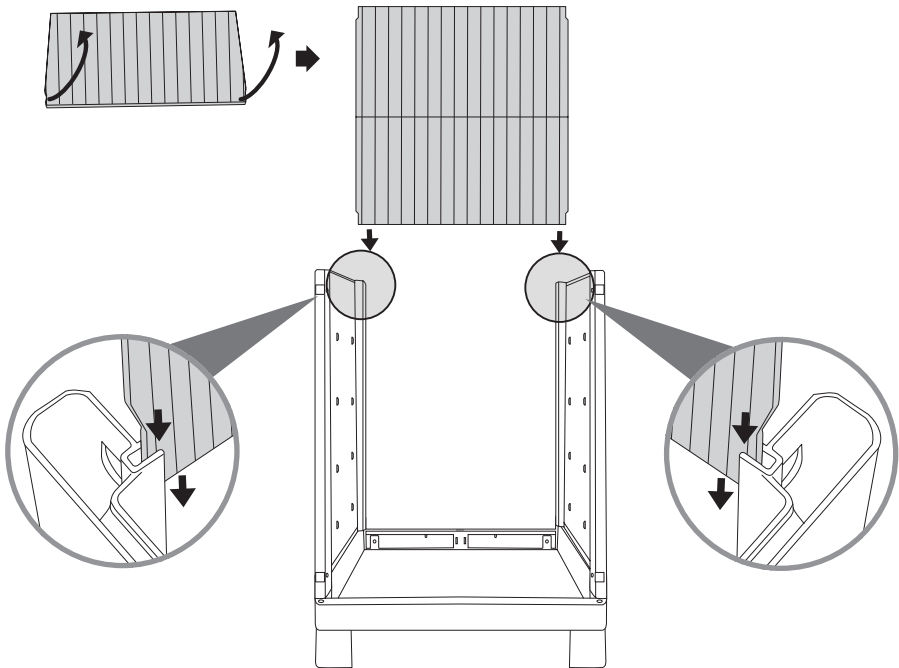

05

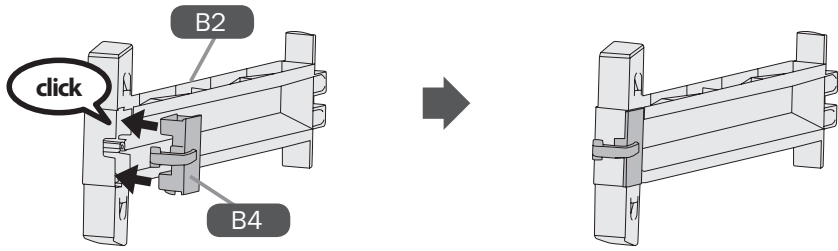

x2

06

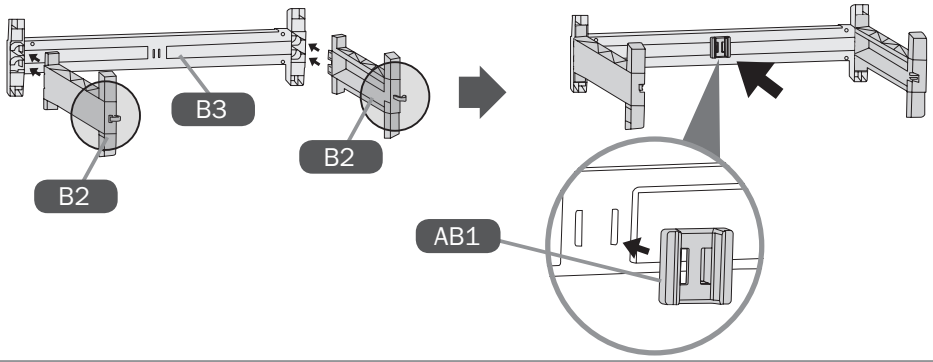

07

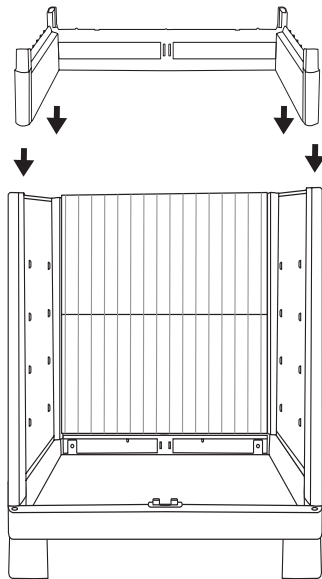

08

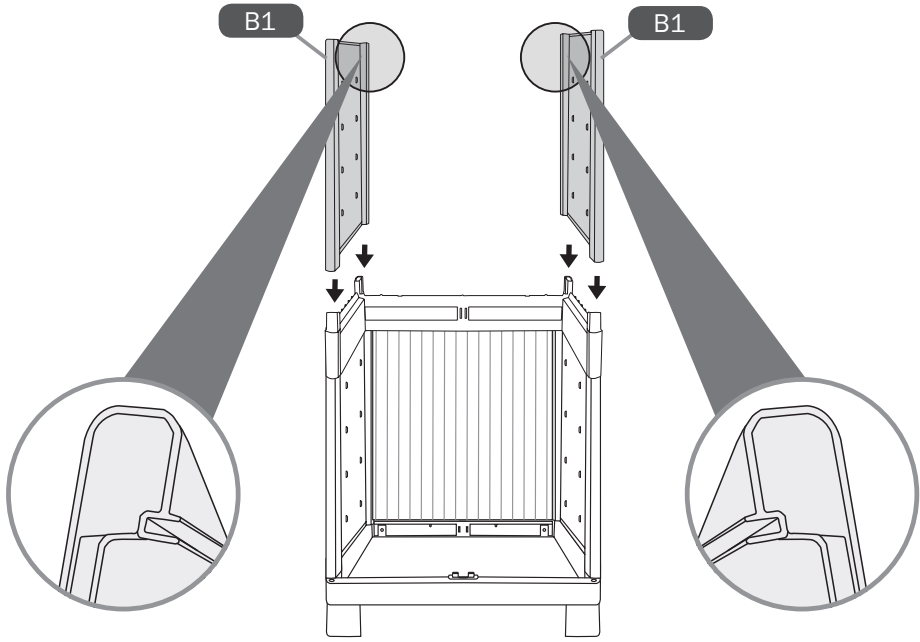

09

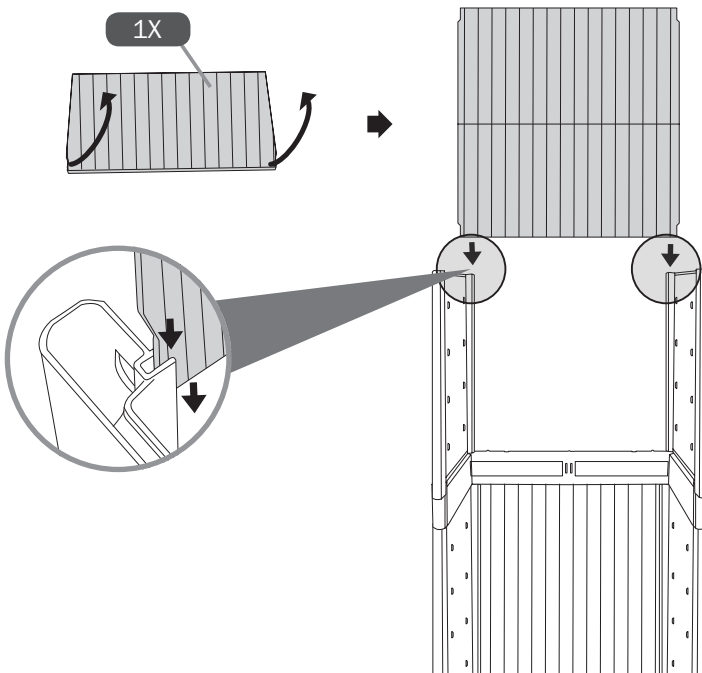

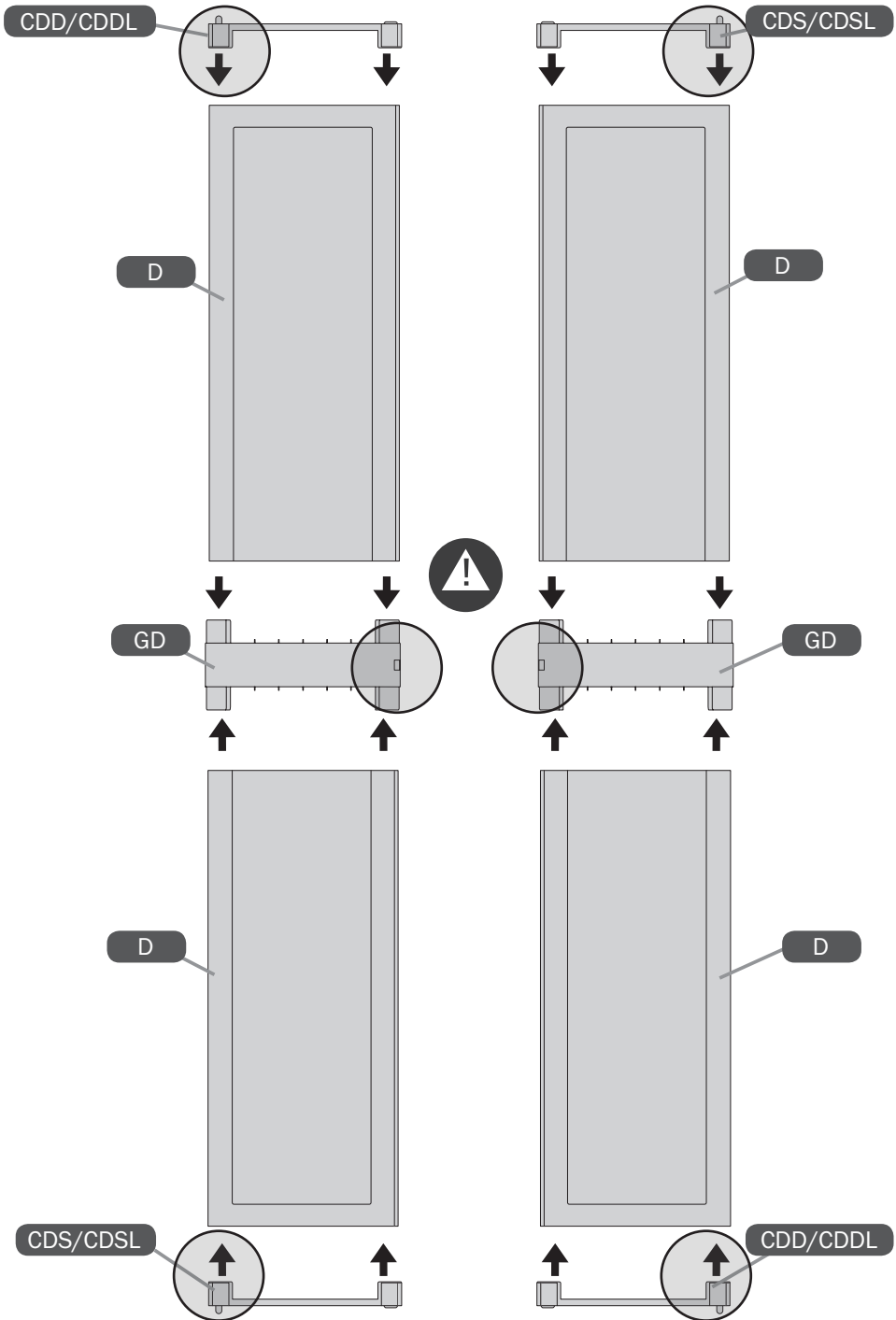

11

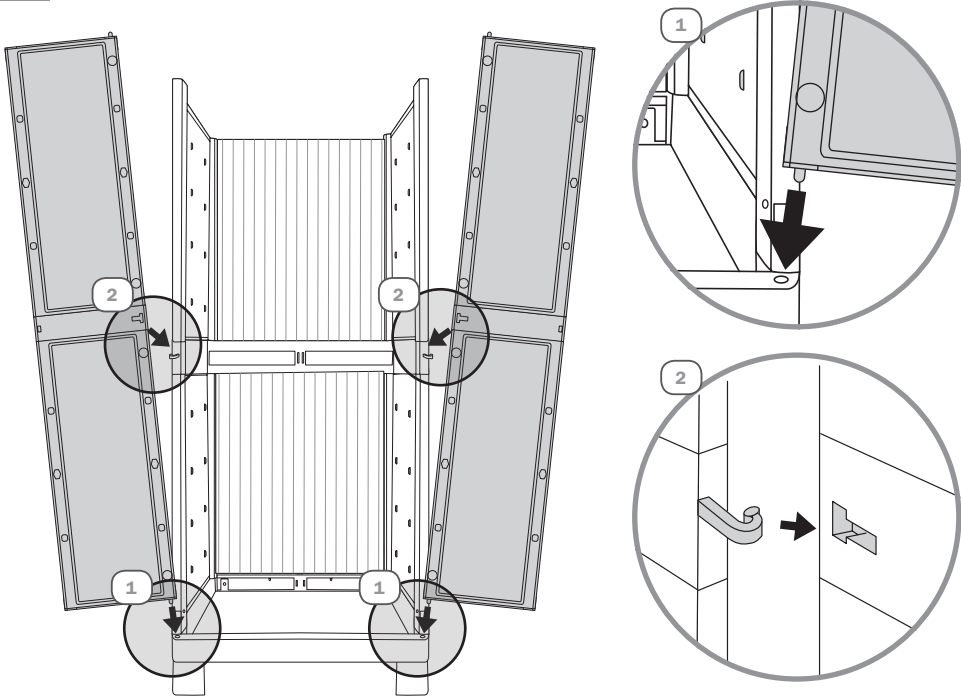

12

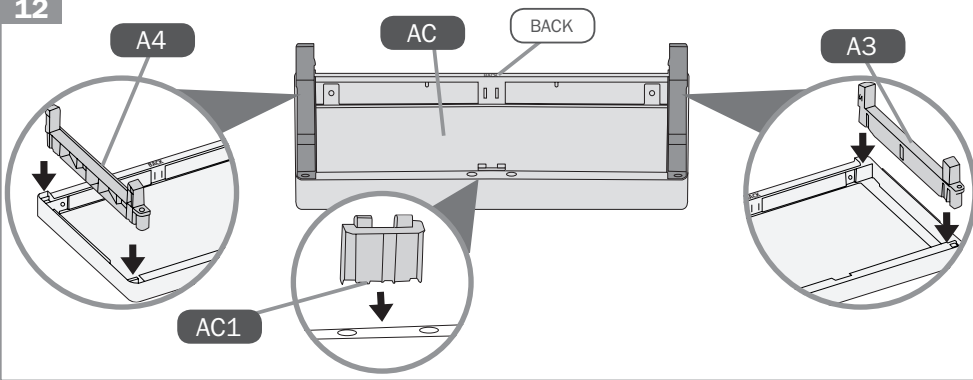

13

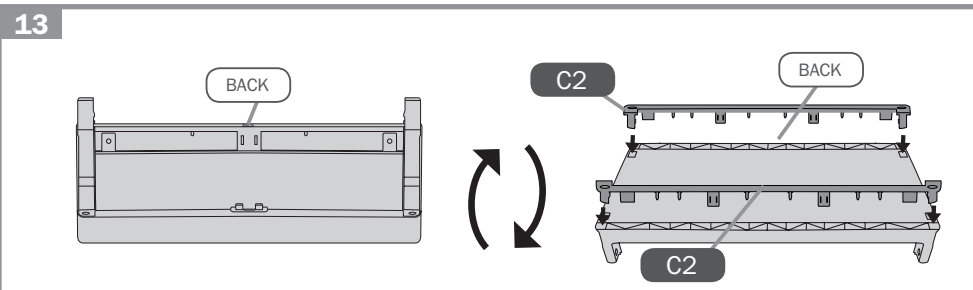



14

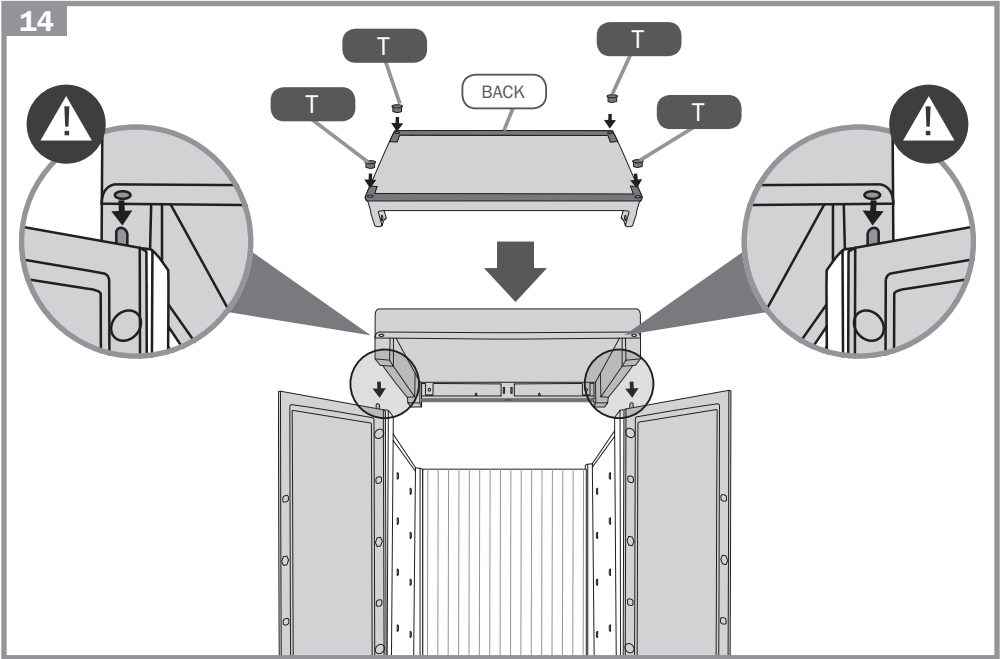

15

8x [3,9X16mm]

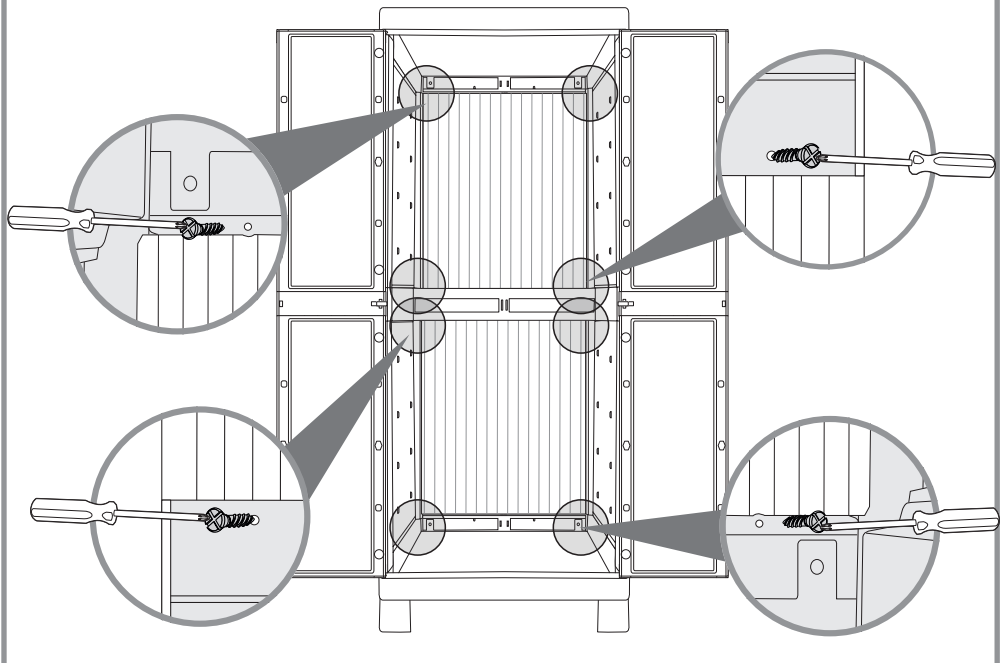

16

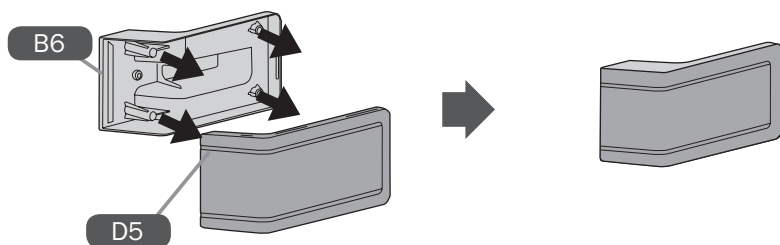

x2

17

4x [4,2X22mm]

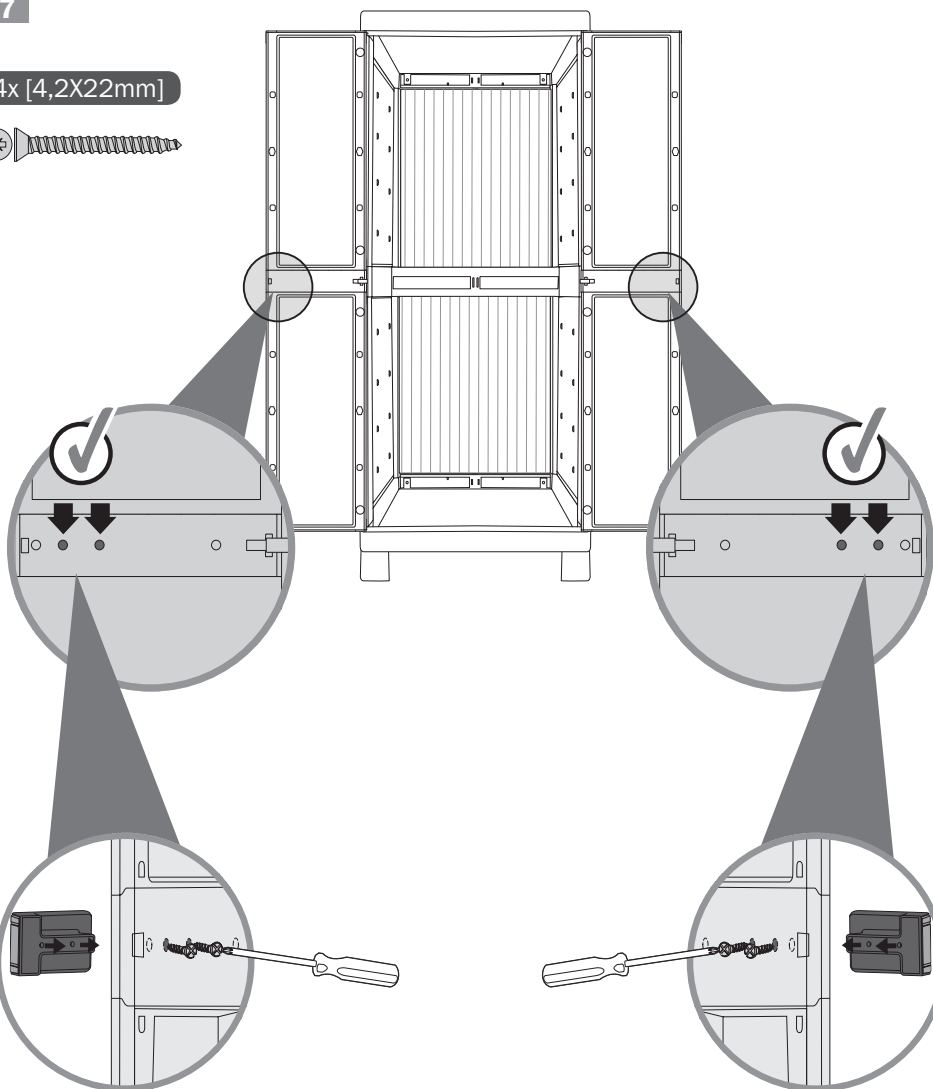

18

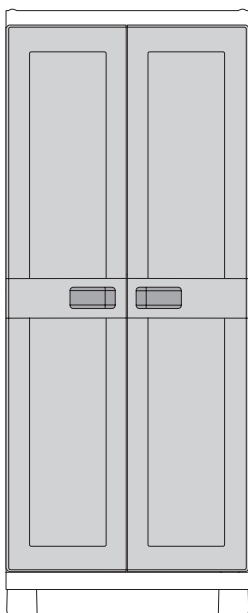

19

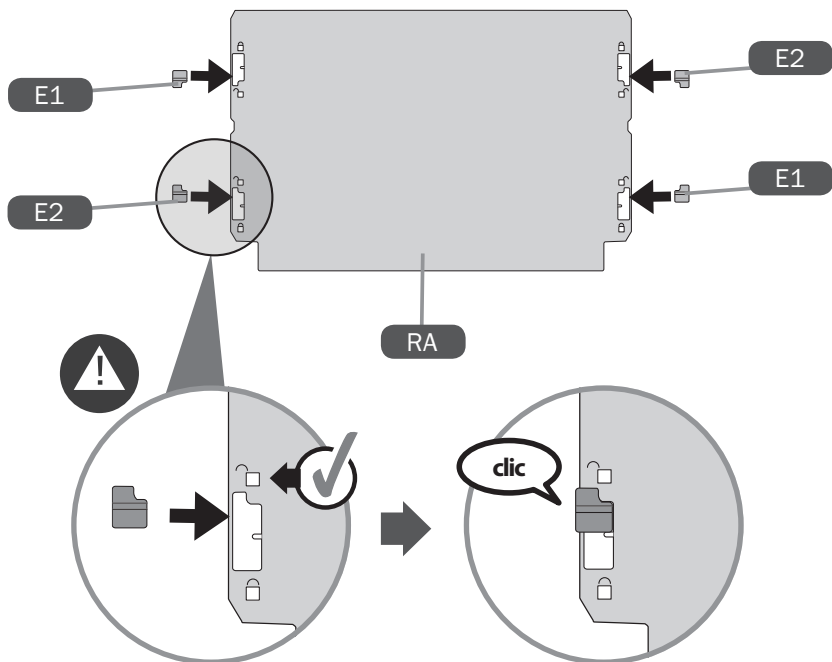

20

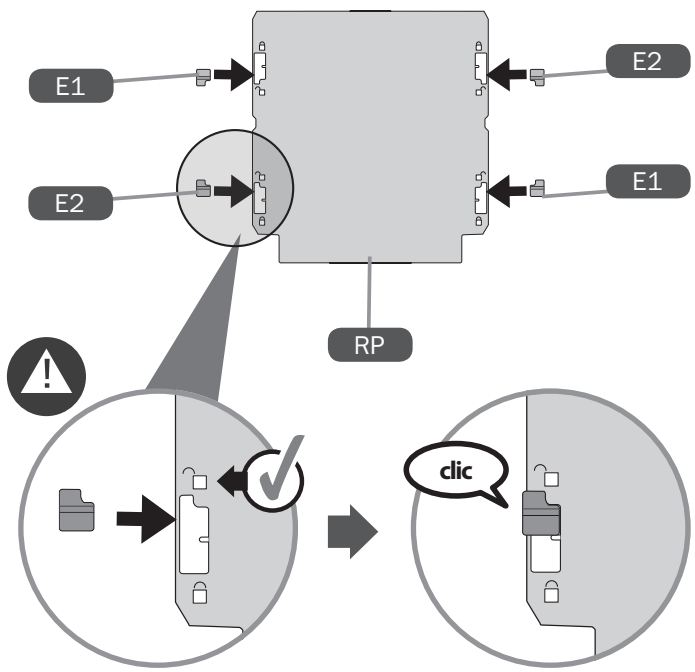

21

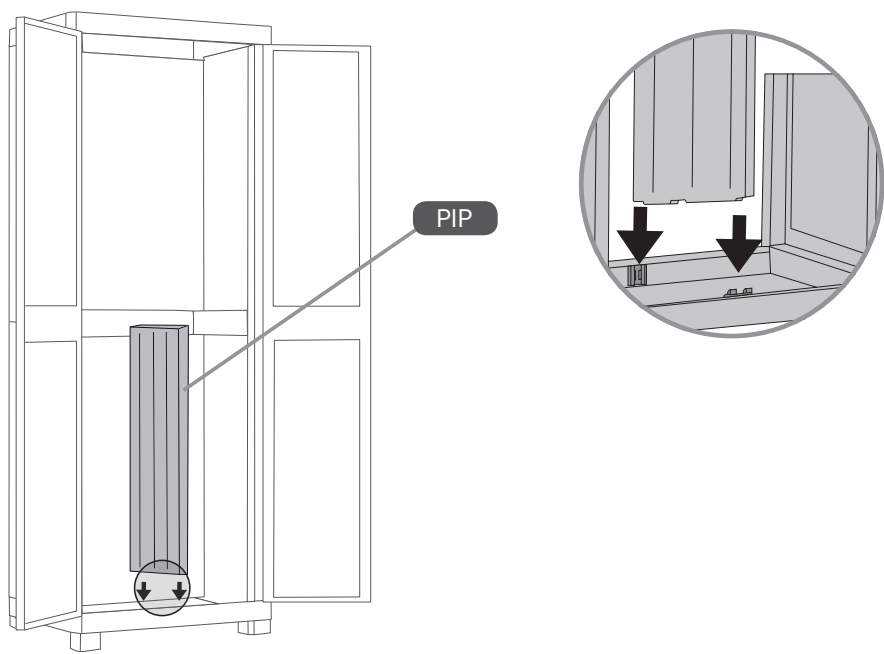

22

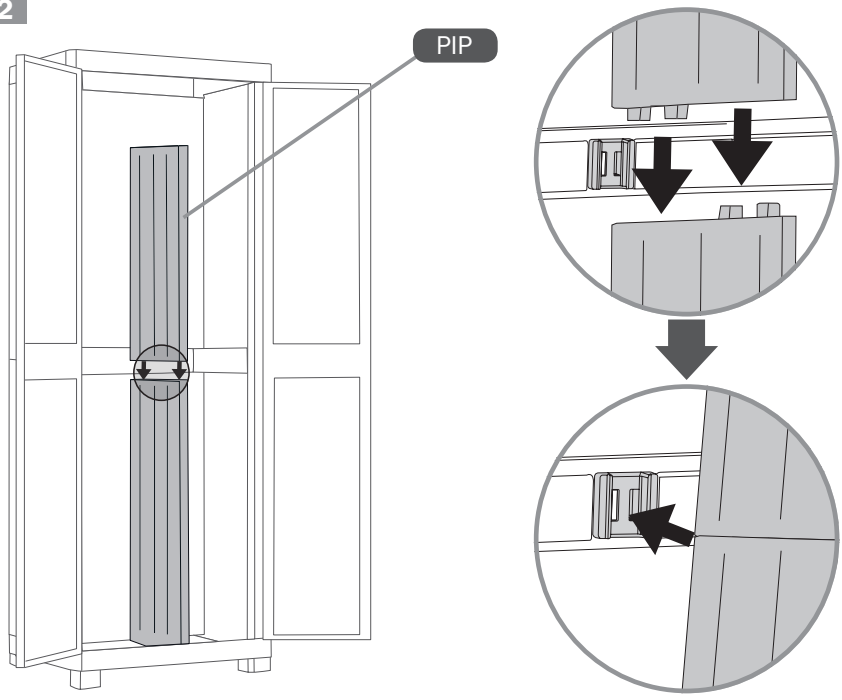

23

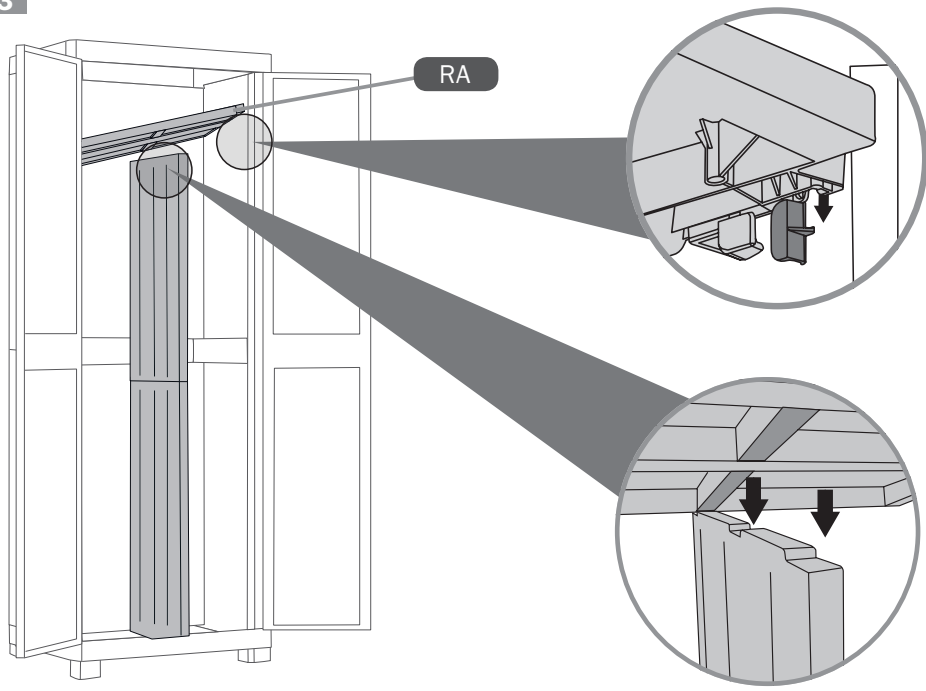

24

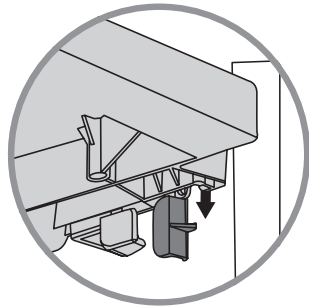
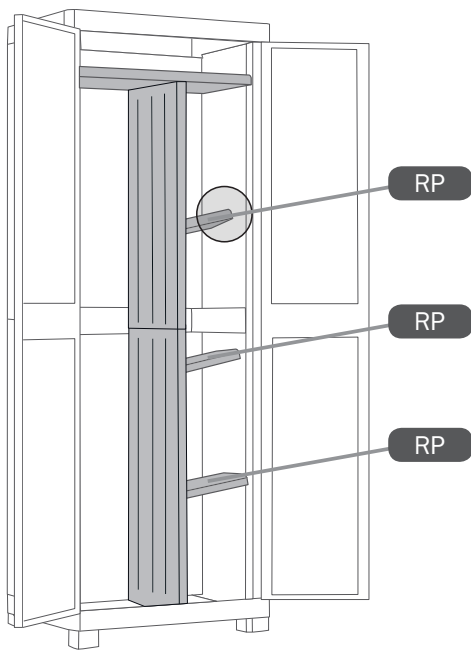

25

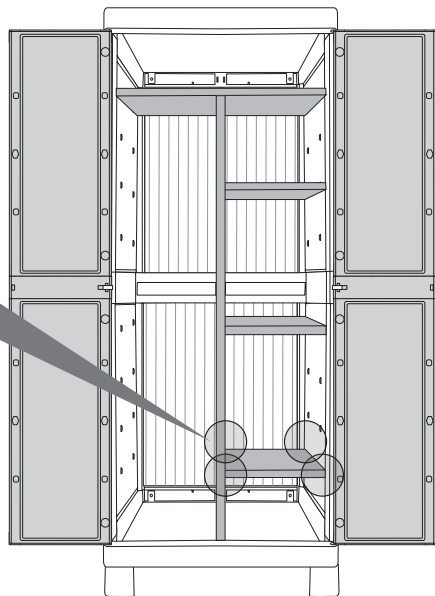
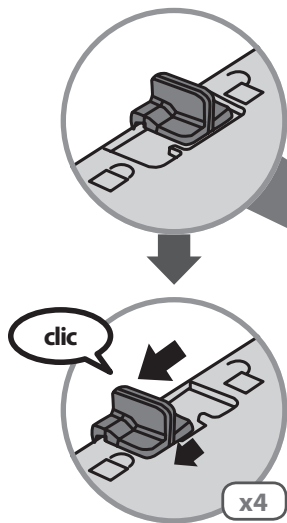

x4

- I** Fissare l'armadio a muro (viti e tasselli non inclusi). Scegliere il tassello in base alla superficie di appoggio. **GB** Fasten the cupboard to the wall (screws and anchors not included). Choose the anchor according to the surface. **D** Befestigen Sie den Schrank an der Wand (Schrauben und Dübel sind nicht im Lieferumfang enthalten). Den Dübel je nach Stellfläche wählen.
- F** Fixer l'armoire au mur (vis et chevilles non incluses). Choisir la cheville en fonction de la surface d'appui. **E** Fije el armario en la pared (la dotación no incluye tornillos y tacos). Elija el taco en función de la superficie de apoyo. **NL** Bevestig de kast aan de muur (schroeven en pluggen niet bijgeleverd). Kies de plug aan de hand van het steunoppervlak. **TR** Dolabı duvara sabitleyin (vidalar ve dübeller dahil değil). Destek yüzeyine göre dübel seçin. **GR** Στερεώστε την ντουλάπα στον τοίχο (βίδες και ούπα δεν περιλαμβάνονται). Επιλέξτε το ούπα ανάλογα με την επιφάνεια στήριξης. **RUS** Закрепите шкаф на стене (шурупы и дюбели не включены в поставку). Возьмите дюбель, пригодный для материала поверхности, у которой ставится шкаф.
- RO** Fixați dulapul la perete (șuruburi și dibluri neincluse în dotare). Alegeți diblul în funcție de suprafața pe care urmează să se fixeze. **CZ** Připevňte skříň ke zdi (šrouby a hmoždinky nejsou součástí dodávky). Zvolte hmoždinku podle povrchu podkladu.
- PL** Przymocować szafę do muru (śruby i kołki nie są zawarte w dostawie). Dobrać kołek w zależności od powierzchni oparcia.

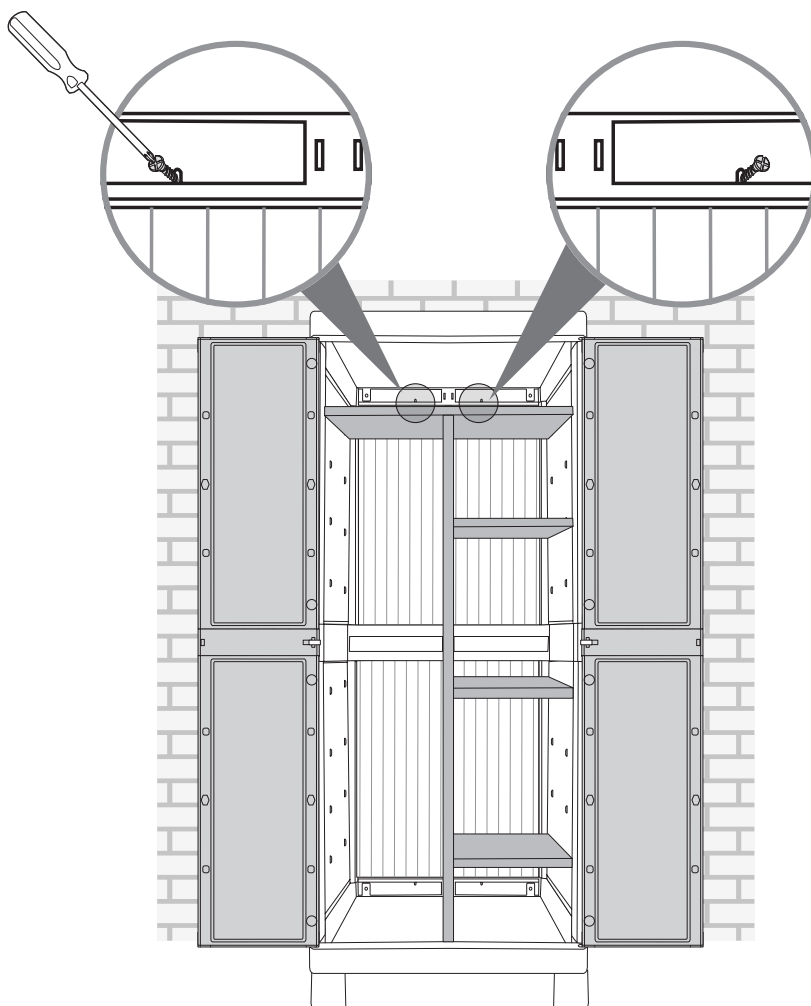

25

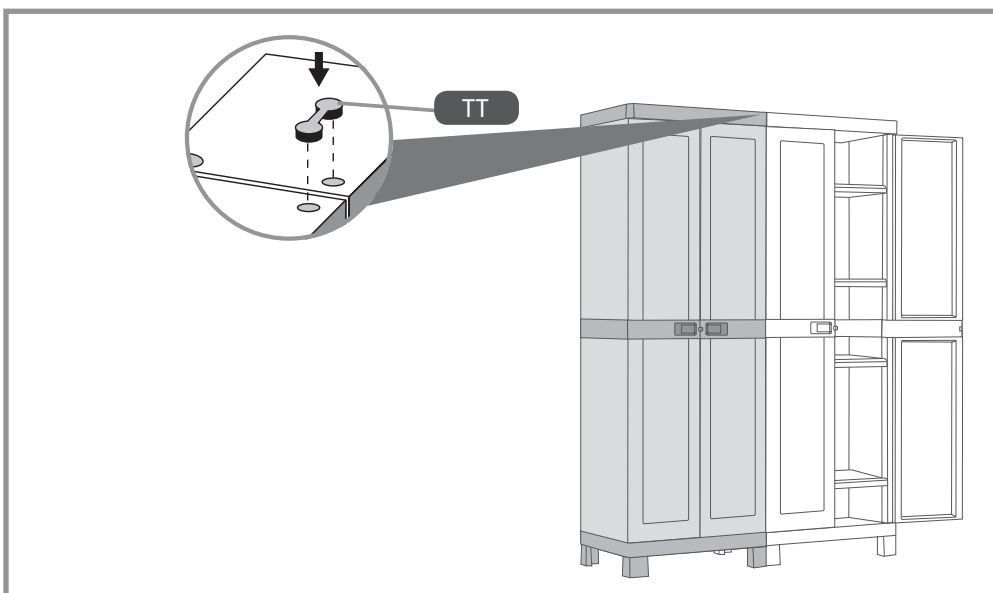
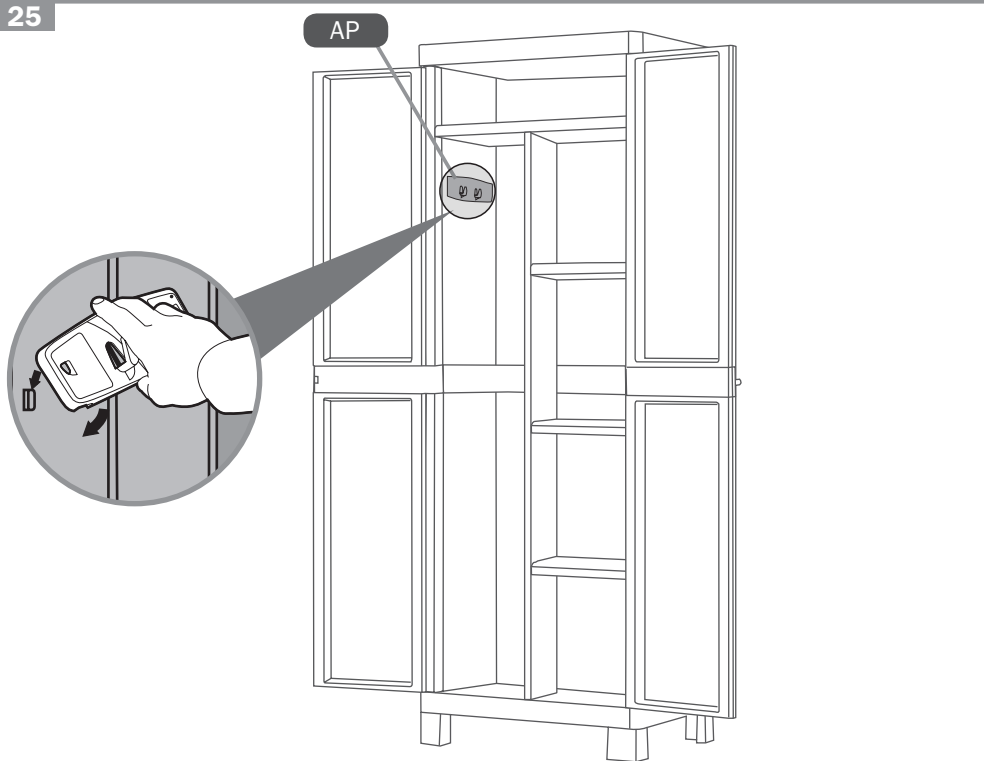

a.b.m. Italia SpA - Via Ing. G. Taliercio 1 - I - 31024 Ormelle (TV)  
Tel. +39 0422 745900 - Fax +39 0422 745999 - info@abmitalia.com - www.kis.it