

SOLE
FITNESS

OWNER'S MANUAL
Model: 16008900880

Please carefully read this entire manual
before operating your new treadmill.

ATTENTION: Before returning your Sole product to any retailer, or if you require any assistance with assembly or technical support please call us first for assistance at 1-888-707-1880. Thank you for your Sole purchase.

TABLE OF CONTENTS

<u>Product Registration</u>	<u>1</u>
<u>Important Safety Instructions</u>	<u>2</u>
<u>Important Electrical Instructions</u>	<u>3</u>
<u>Important Operation Instructions</u>	<u>4</u>
<u>Assembly instructions</u>	<u>8</u>
<u>Transport Instructions</u>	<u>12</u>
<u>Operation of Your New Treadmill</u>	<u>13</u>
<u>Bluetooth® Connectivity</u>	<u>16</u>
<u>Programmable Features</u>	<u>18</u>
<u>General Maintenance</u>	<u>28</u>
<u>Service Checklist - Diagnosis Guide</u>	<u>30</u>
<u>Manufacturer's Limited Warranty</u>	<u>37</u>

SOLE

FITNESS

CONGRATULATIONS ON YOUR NEW TREADMILL AND WELCOME TO THE SOLE FAMILY!

Thank you for your purchase of this quality treadmill from Dyaco Canada Inc. Your new treadmill has been manufactured by one of the leading fitness manufacturers in the world and is backed by one of the most comprehensive warranties available. Dyaco Canada Inc. will do all we can to make your ownership experience as pleasant as possible for many years to come.

If you have any questions about your new Sole product or questions about the warranty contact Dyaco Canada Inc. at 1-888-707-1880.

Please take a moment at this time to record below the name of the dealer, their telephone number and the date of purchase for easy contact in the future. We appreciate your confidence in **SOLE** and we will always remember that you are the reason that we are in business. Please complete and mail your registration card today and enjoy your new treadmill.

Yours in Health,
Dyaco Canada Inc.

Name of Dealer _____

Telephone Number of Dealer _____

Purchase Date _____

PRODUCT REGISTRATION

RECORD YOUR SERIAL NUMBER

Please record the Serial Number of this fitness product in the space provided below.

Serial Number _____

REGISTER YOUR PURCHASE

The self-addressed product registration card must be completed in full and returned to Dyaco Canada Inc. You can also go to www.solefitness.ca to register online.



IMPORTANT SAFETY INSTRUCTIONS

WARNING - Read all instructions before using this equipment.

DANGER - To reduce the risk of electric shock disconnect your SOLE treadmill from the electrical outlet prior to cleaning and/or service work.

WARNING - To reduce the risk of burns, fire, electric shock, or injury to persons, install the treadmill on a flat level surface with access to a 120-volt, 15-amp grounded outlet with only the treadmill plugged into the circuit.

DO NOT USE AN EXTENSION CORD UNLESS IT IS A 14AWG OR BETTER, WITH ONLY ONE OUTLET ON THE END: DO NOT ATTEMPT TO DISABLE THE GROUNDED PLUG BY USING IMPROPER ADAPTERS, OR IN ANY WAY MODIFY THE CORD SET.

A serious shock or fire hazard may result along with computer malfunctions. See Grounding Instructions, page 3.

- Do not operate treadmill on deeply padded, plush or shag carpet. Damage to both carpet and treadmill may result.
- Do not block the rear of the treadmill. Provide a minimum of 3 1/2 feet clearance between the rear of the treadmill and any fixed object.
- Keep children under the age of 13 away from this machine. There are obvious pinch points and other caution areas that can cause harm.
- Keep hands away from all moving parts.
- Never operate the treadmill if it has a damaged cord or plug. If the treadmill is not working properly, call your dealer.
- Keep the cord away from heated surfaces.
- Do not operate where aerosol spray products are being used or where oxygen is being administered. Sparks from the motor may ignite a highly gaseous environment.
- Never drop or insert any object into any openings.
- Do not use outdoors.
- To disconnect, turn all controls to the off position, remove tether cord, and then remove the plug from the outlet.
- Do not attempt to use your treadmill for any purpose other than for the purpose it is intended.
- The pulse sensors are not medical devices. Various factors, including the user's movement, may affect the accuracy of heart rate readings. The pulse sensors are intended only as exercise aids in determining heart rate trends in general.
- Use handrails provided; they are for your safety.
- Wear proper shoes. High heels, dress shoes, sandals or bare feet are not suitable for use on your treadmill. Quality athletic shoes are recommended to avoid leg fatigue.
- This equipment is not intended for use by persons with reduced physical, sensory or mental capabilities, or lack of experience and knowledge, unless they have been given supervision or instruction concerning use of the equipment by a person responsible for their safety.

Remove tether cord after use to prevent unauthorized treadmill operation.

SAVE THESE INSTRUCTIONS - THINK SAFETY!

IMPORTANT ELECTRICAL INSTRUCTIONS

WARNING!

NEVER use a ground fault circuit interrupt (GFCI) wall outlet with this treadmill. As with any equipment with a large motor, the GFCI will trip often. Route the power cord away from any moving part of the treadmill including the elevation mechanism and transport wheels.

NEVER remove any cover without first disconnecting AC power.

If voltage varies by ten percent (10%) or more, the performance of your treadmill may be affected. Such conditions are not covered under your warranty. If you suspect the voltage is low, contact your local power company or a licensed electrician for proper testing.

NEVER expose this treadmill to rain or moisture. This product is NOT designed for use outdoors, near a pool or spa, or in any other high humidity environment. The maximum operating temperature specification is 40 degrees c, and humidity is 95% non-condensing (no water drops forming on surfaces).

Circuit Breakers: Some circuit breakers used in homes are not rated for high inrush currents, (ARC fault breakers are one example) that can occur when a treadmill is first turned on or even during use. If your treadmill is tripping the house circuit breaker (even though it is the proper current rating) but the circuit breaker on the treadmill itself does not trip, you will need to replace the home breaker with a high inrush type. This is not a warranty defect. This is a condition we as a manufacture have no ability to control. This part is available through most electrical supply stores. Examples:

Grainger part # 1D237, or available online at www.squared.com part # QO120HM.

GROUNDING INSTRUCTIONS

This product must be grounded. If the treadmill should malfunction or breakdown, grounding provides a path of least resistance for electric current, reducing the risk of electric shock. This product is equipped with a cord having an equipment-grounding plug. The plug must be plugged into an appropriate outlet that is properly installed and grounded in accordance with all local codes and ordinances.

DANGER - Improper connection of the equipment-grounding conductor can result in a risk of electric shock. Check with a qualified electrician or serviceman if you are in doubt as to whether the product is properly grounded. Do not modify the plug provided with the product if it will not fit the outlet; have a proper outlet installed by a qualified electrician.

This product is for use on a nominal 110-volt circuit, and has a grounding plug that looks like the plug illustrated below. A temporary adapter that looks like the adapter illustrated below may be used to connect this plug to a 2-pole receptacle as shown below if a properly grounded outlet is not available. The temporary adapter should be used only until a properly grounded outlet, (shown below) can be installed by a qualified electrician. The green colored rigid ear-

lug, or the like, extending from the adapter, must be connected to a permanent ground such as a properly grounded outlet box cover. Whenever the adapter is used, it must be held in place by a metal screw.

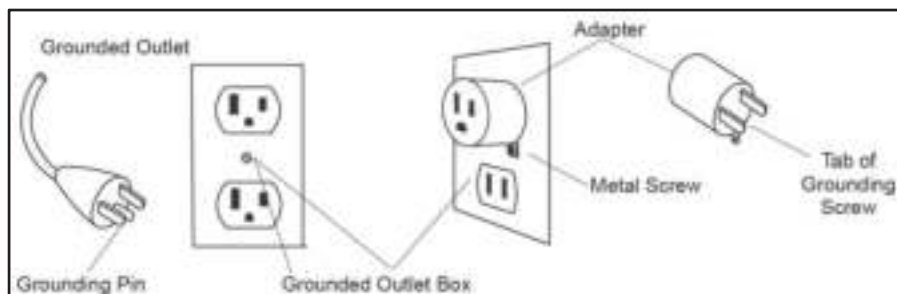

IMPORTANT OPERATION INSTRUCTIONS

- **NEVER** operate this treadmill without reading and completely understanding the results of any operational change you request from the computer.
- Understand that changes in speed and grade do not occur immediately. Set your desired speed on the computer console and release the adjustment key. The computer will obey the command gradually.
- **NEVER** use your treadmill during an electrical storm. Surges may occur in your household power supply that could damage treadmill components. Unplug the treadmill during an electrical storm as a precaution.
- Use caution while participating in other activities while walking on your treadmill; such as watching television, reading, etc. These distractions may cause you to lose balance or stray from walking in the center of the belt; which may result in serious injury.
- **NEVER** mount or dismount the treadmill while the belt is moving. **SOLE** treadmills start at a very low speed and it is unnecessary to straddle the belt during start up. Simply standing on the belt during slow acceleration is proper after you have learned to operate the unit.
- Always hold on to a handrail or hand bar while making control changes (grade, speed, etc.).
- Do not use excessive pressure on console control keys. They are precision set to function properly with little finger pressure. Pushing harder is not going to make the unit go faster or slower. If you feel the buttons are not functioning properly with normal pressure contact your **SOLE** dealer.

SAFETY KEY INSTRUCTIONS

A safety tether cord is provided with this unit and should be used at all times. It is for your safety should you fall or move too far back on the tread-belt. Pulling this safety tether cord will stop tread-belt movement.

To Use:

1. Place the safety key into position on the console control head. Your treadmill will not start and operate without this. Removing the safety key also secures the treadmill from unauthorized use.
2. Fasten the plastic clip onto your clothing securely to assure good holding power.
Note: *The clip should be attached securely to make certain it does not come off. Be familiar with its function and limitations. The treadmill will stop, depending on speed, with a one to two step coast anytime the safety key is pulled off the console. Use the red **Stop** switch in normal operation.*
3. If the console displays "Safety key removed, machine stopped, click Replace the key to Operate", put the Safety key back to continue using the treadmill.

IMPORTANT SAFETY INSTRUCTIONS

READ BEFORE UNPACKING YOUR FOLDING TREADMILL

Serious injury could occur if this folding treadmill is not unpacked properly.

There is a Velcro strap installed around the treadmill base that prevents the treadmill from unfolding accidentally during shipping. If this strap is not removed properly the treadmill could spring open unexpectedly and cause injury if someone is standing near the treadmill when the strap is removed.

To ensure your personal safety during removal of the shipping strap please make sure the treadmill is positioned flat on the ground, in the orientation it would be in if you were using the treadmill. Do not turn the treadmill up on its side while removing the shipping strap. This could cause the treadmill's folding mechanism to spring open. If the end of the Velcro strap (that you need to grab to remove it) happens to be under the treadmill deck, reach under the deck to grab it, but do not tilt the treadmill up to gain access to the strap end.

PREVENTATIVE MAINTENANCE CHART

Vacuum Under Motor Cover & Check Wiring (Every Other Month)	Clean & Inspect Deck for Lubrication (Every Other Month)	Lubricate Deck (Every 90 hours or sooner if dry)	Inspect Belt Tracking (Monthly) Adjust if necessary	Date

TT8 ASSEMBLY PACK CHECKLIST

3 HARDWARE STEP 3



#85. $\varnothing 10 \times 2T$
Split Washer (6 pcs)

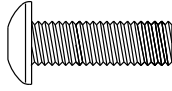

#99. $5/16'' \times 3/4''$ Flat
Head Socket Bolt
(4 pcs)

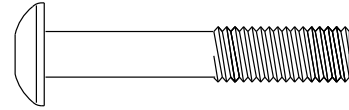

#100. $3/8'' \times 2-1/4''$ Button
Head Socket Bolt (6 pcs)

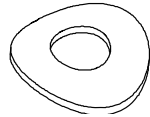

#131. $\varnothing 8 \times \varnothing 23 \times 1.5T$ Curved
Washer (4 pcs)

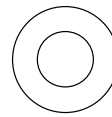

#102. $3/8'' \times 19 \times 1.5T$
Flat Washer (6 pcs)

5 HARDWARE STEP 5



#85. $\varnothing 10 \times 2T$
Split Washer (4 pcs)

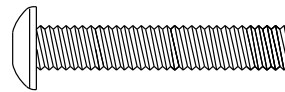

#125. $3/8'' \times 1-3/4''$ Button
Head Socket Bolt (4 pcs)

6 HARDWARE STEP 6

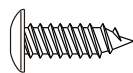

#90. $3.5 \times 16mm$
Sheet Metal Screw (4 pcs)

7 HARDWARE STEP 7

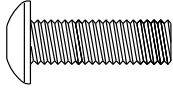

#99. 5/16" x 3/4"
Flat Head Socket Bolt (4 pcs)

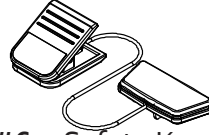

#63. Safety Key

8 HARDWARE STEP 8

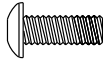

#126. M5 x 10mm
Phillips Head Screw (4 pcs)

9 HARDWARE STEP 9

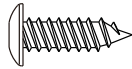

#90. 3.5 x 16mm
Sheet Metal Screw (4 pcs)

ASSEMBLY TOOLS

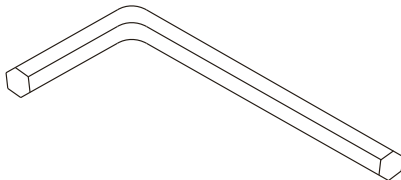

#104. L Allen Wrench

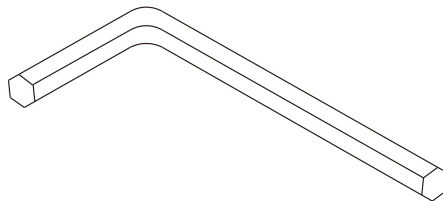

#105. M6 L Allen Wrench

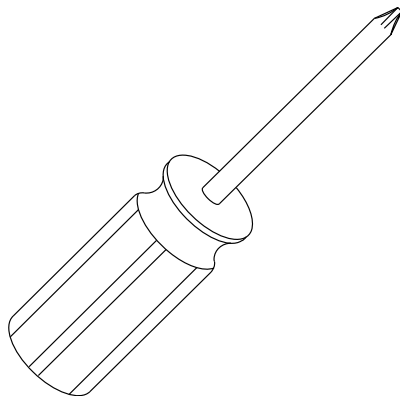

#188. Phillips Head Screwdriver

TT8 ASSEMBLY INSTRUCTIONS

1 ASSEMBLY STEP 1

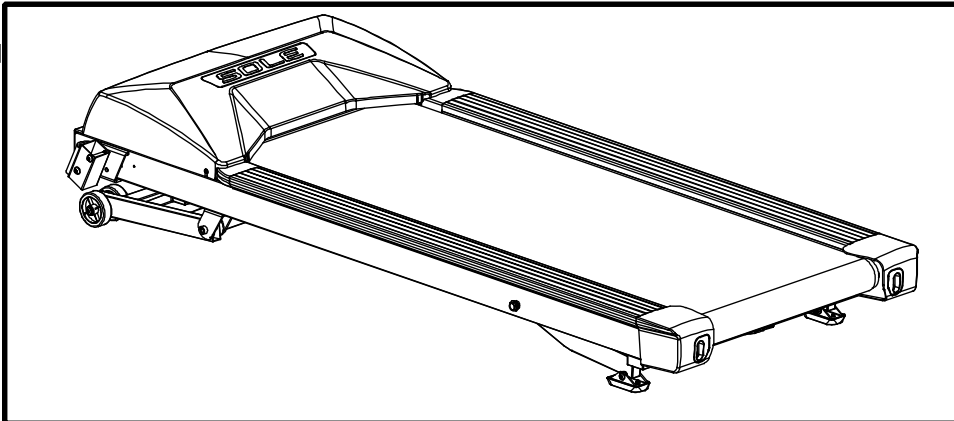

1. Remove the treadmill base frame from the carton and lay it aside on firm, level ground.

2 ASSEMBLY STEP 2

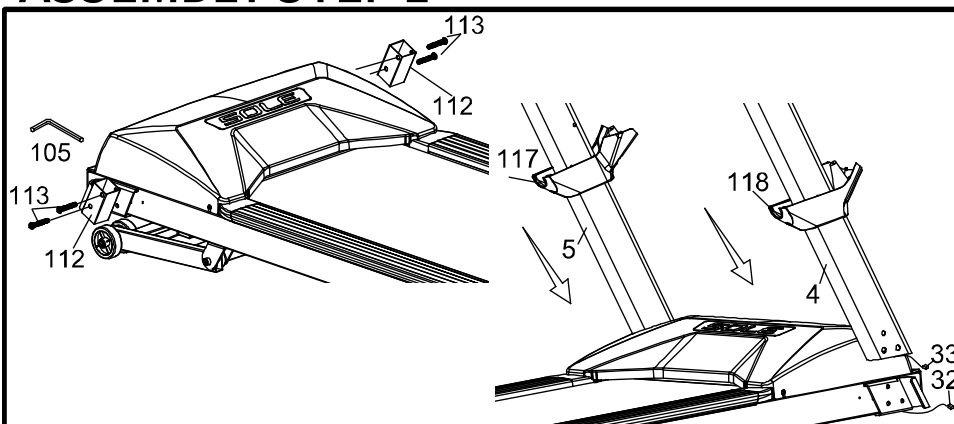

1. Remove(L/R) Flat Head Socket Bolts (**113**) with L Allen Wrench (**105**) and then remove 2 pcs Fixing Plate Stabilizer (**112**)
2. Locate the left and right Uprights (**5** & **4**). Slide the Console Mast Cover (**117**) onto the left and right (**118**) uprights as shown in the illustration.
3. Connect the Computer Cable Lower (**32**) of the Main Frame with the Computer Cable Middle (**33**) at the bottom of the right Upright (**4**).

Before attaching the hardware to Step 3, make sure the cables you just connected don't get pinched in between the steel tubing. If they do, this may cause issues that prevent the treadmill from operating properly.

3 ASSEMBLY STEP 3

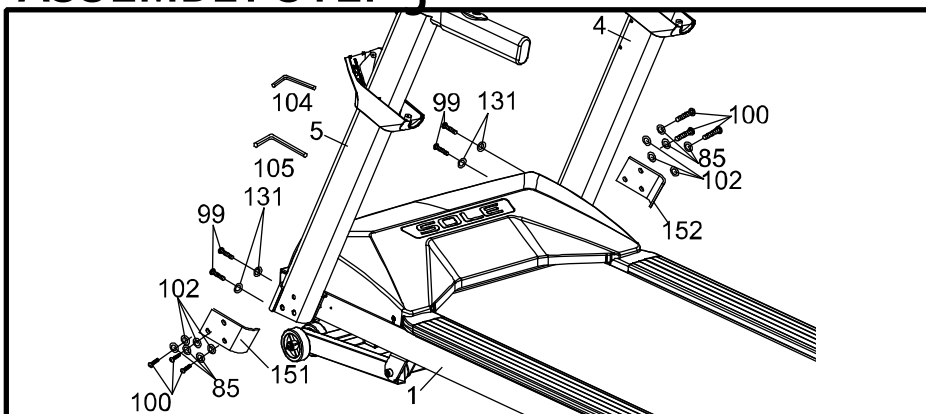

HARDWARE STEP 3

- #85. $\varnothing 10 \times 2T$
Split Washer (6 pcs)
- #99. $5/16'' \times 3/4''$ Flat
Head Socket Bolt
(4 pcs)
- #100. $3/8'' \times 2-1/4''$
Button Head Socket
Bolt (6 pcs)
- #131. $\varnothing 8 \times \varnothing 23 \times 1.5T$
Curved Washer (4 pcs)
- #102. $3/8'' \times 19 \times 1.5T$
Flat Washer (6 pcs)

1. Attach the left and right Upright Tubes (5 & 4) to the Main Frame (1). Be careful installing the right upright so that the wire harness doesn't get pinched or cut. **Only hand-tighten all the bolts in this step. The bolts will need to be completely tightened after the console is installed.** Insert three Split Washers (85), three Flat Washers (102), and three Button Head Socket Bolts (100) through the brackets (151 & 152) and Uprights (5 & 4) and into the frame. Partially tighten with the M6 L Allen Wrench (105). Attach two Curved Washers (131) and two Flat Head Socket Bolts (99) to the front of each Console Mast Tube. Partially tighten with the L Allen Wrench (104).

4 ASSEMBLY STEP 4

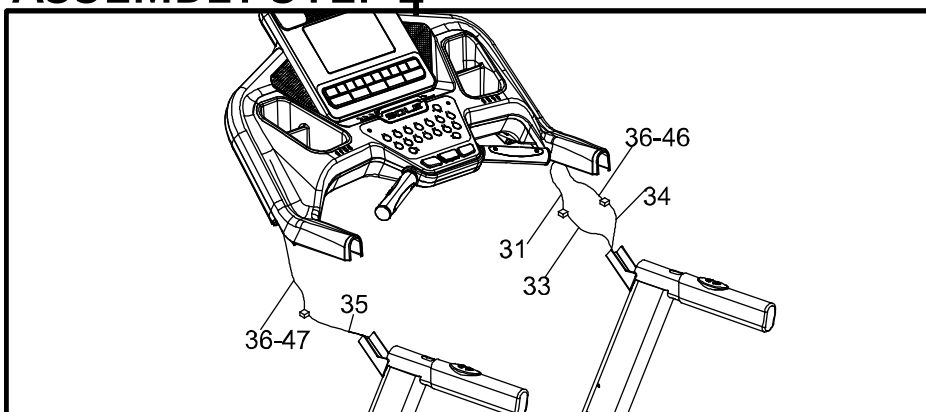

1. Connect the middle Computer Cable (33) to the upper Computer Cable (31), the Speed Adjustment Switch w/Cable (34) to the Upper Speed Cable (36-46), and the Incline Adjustment Switch w/Cable (35) to the Upper Incline Cable (36-47).

Before attaching the hardware to Step 5, make sure the cables you just connected don't get pinched in between the steel tubing. If they do, this may cause issues that prevent the treadmill from operating properly.

5 ASSEMBLY STEP 5

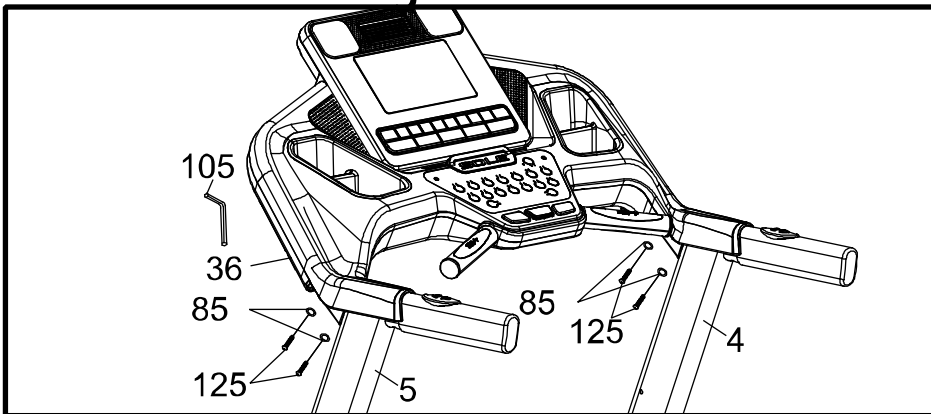

HARDWARE STEP 5

#85. $\varnothing 10 \times 2T$
Split Washer (4 pcs)
#125. $3/8" \times 1-3/4"$
Button Head Socket
Bolt (4 pcs)

1. Carefully attach the Console Assembly (36) to the top of the upright tubes (5 & 4) with the four Button Head Socket bolts (125) and four Split Washers (85). Make sure the cables don't get pinched between the joint or by the bolts. Tighten the bolts completely using the M6 Allen Wrench (105).

6 ASSEMBLY STEP 6

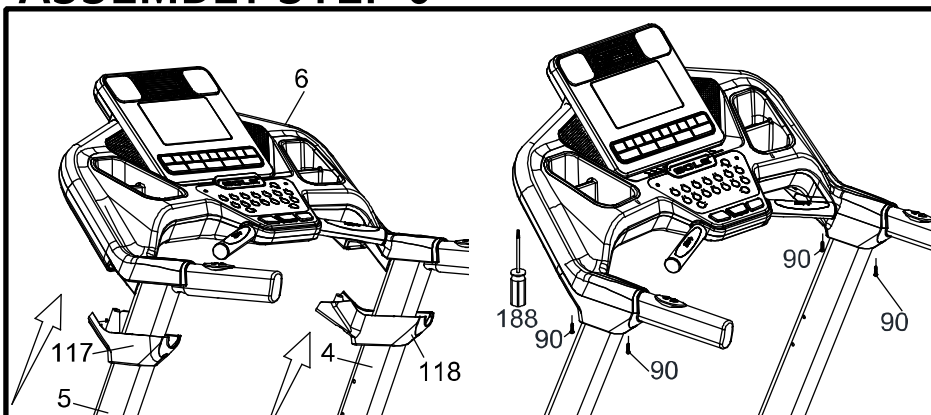

HARDWARE STEP 6

#90. $3.5 \times 16\text{mm}$
Sheet Metal Screw
(4 pcs)

1. Attach the Left (117) and Right (118) Console Mast Covers to the console with four Sheet Metal Screws (90). Tighten with the Phillips Head Screwdriver (188).

7 ASSEMBLY STEP 7

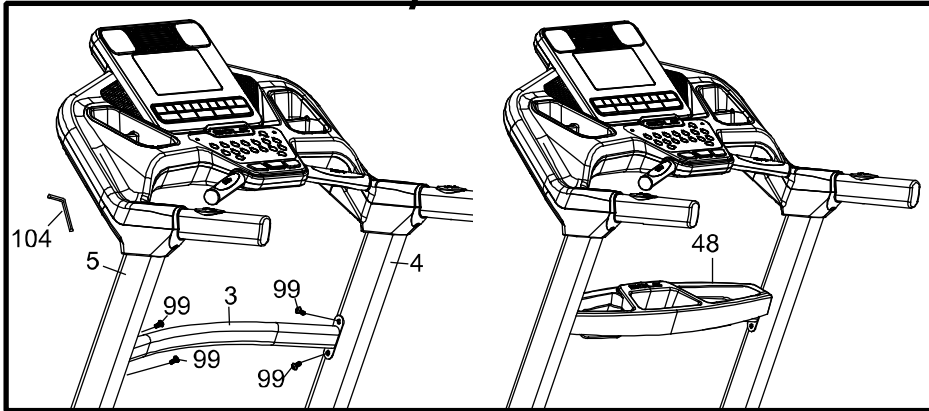

HARDWARE STEP 7

#99. 5/16" x 3/4"
Flat Head Socket Bolt
(4 pcs)
#63. Safety Key

1. Attach the Handrail Support (3) between the upright tubes (4 & 5) with the four Flat Head Socket bolts (99). Tighten the bolts completely using the Combination L Allen Wrench (104).
2. Place the Beverage Holder (48) on top of the Handrail Support (3) as shown in the illustration.
3. Place the magnet of the safety key (63) in between the Start and Stop buttons (if it isn't already attached). The treadmill will not function without this in place.
4. Check to make sure all bolts and screws are completely tightened.

8 ASSEMBLY STEP 8

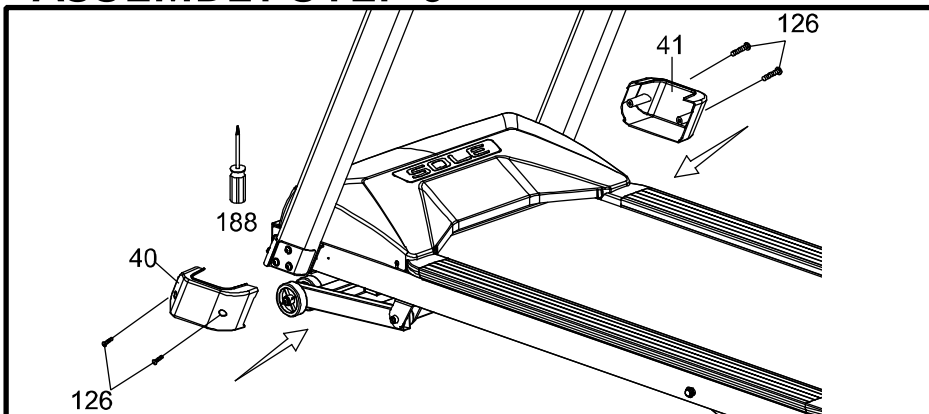

HARDWARE STEP 8

#126. M5 x 10mm
Phillips Head Screw
(4 pcs)

1. Completely tighten the bolts that secure the Console Mast Tubes to the frame with the M6 Allen Wrench (105).
2. Attach the Frame Base Covers (40L & 41R) to each upright (5 & 4) with two Phillips Head Screws (126) on each side. Tighten using the Phillips Head Screwdriver (188).

9

ASSEMBLY STEP 9

HARDWARE STEP 9

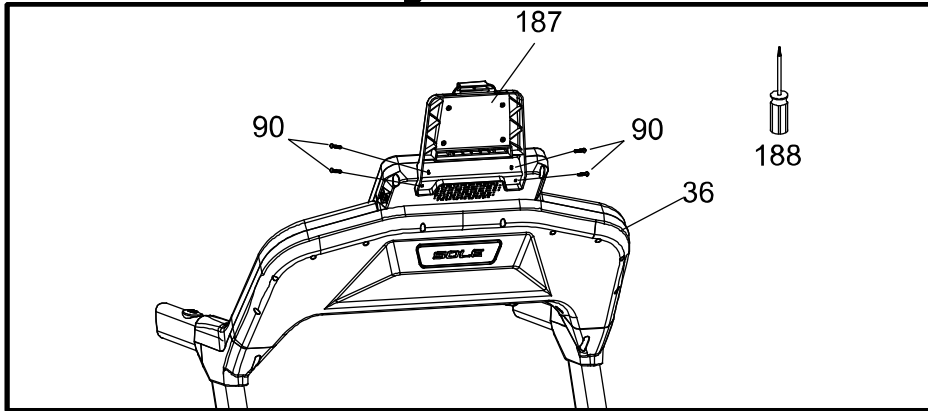

#90. 3.5 x 16mm
Sheet Metal Screw
(4 pcs)

1. Insert Tablet Holder (187) into the Console Assembly (36) and use Phillips Head Screwdriver (188) to tighten four of Sheet Metal Screw (90).

TRANSPORTATION INSTRUCTIONS

The treadmill is equipped with transport wheels that are engaged when the treadmill is folded. After folding simply roll the treadmill away.

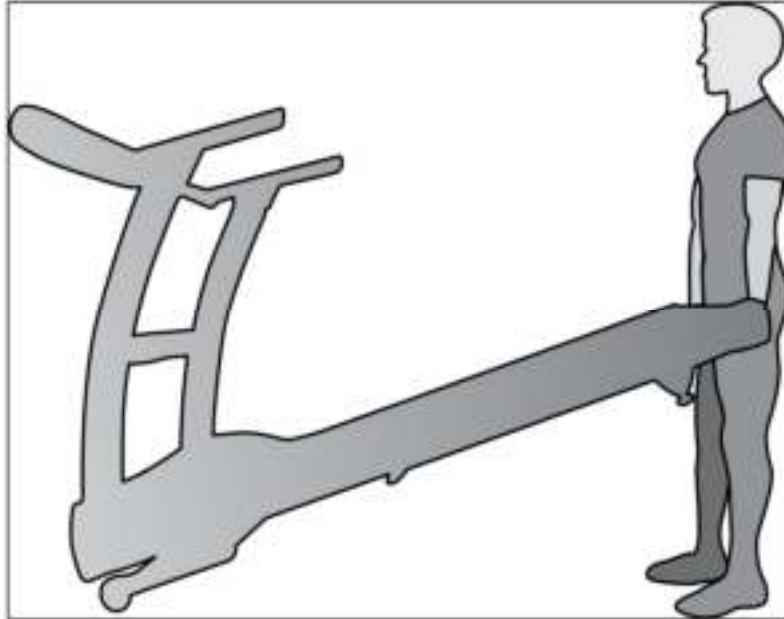

OPERATION OF YOUR TREADMILL

GETTING FAMILIAR WITH THE CONTROL PANEL



GETTING STARTED

TT8 CONSOLE

Power the treadmill on by plugging it into an appropriate wall outlet, then turn on the power switch located at the front of the treadmill below the motor hood. Ensure that the **Safety Key** is installed, as the treadmill will not power on without it (*See Assembly Step 7 for reference*).



When the power is turned on, the boot screen will display Odometer readings for a short time, Total time will show how many hours the treadmill has been in use and the total distance will show how many miles (or Kilometers if the treadmill is set to metric readings) the treadmill has

gone. The treadmill will then enter idle mode, which is the starting point for operation.

START OPERATION

1. Attach the **Safety Key** to wake display up (if not already on).
2. Press the **Start** key to begin belt movement then adjust to the desired speed using the **Speed ▲/▼** keys (console or handgrip). You may also use the speed keys 2, 3, 4, 5, 7, 9, or 12 to adjust the speed.
3. To slow tread-belt press and hold the **Slow** key (console or handgrip) to the desired speed. You may also press the speed adjust keys, 2 through 12.
4. To stop the tread-belt, press the **Stop** key or pull away the **Safety Key**.



PAUSE/STOP/RESET FEATURE

1. When the treadmill is running the pause feature may be utilized by pressing the red **Stop** key once. This will slowly decelerate the tread-belt to a stop. The grade will go to zero percent. The **Time, Distance** and **Calorie** readings will hold while the unit is in the pause mode. After 5 minutes the display will reset and return to the start up screen.
2. To resume your exercise, when in Pause mode, press the **Start** key. The speed and grade will return to their previous settings.
 - Pause is executed when the **Stop** button is pressed once. If the **Stop** button is pressed a second time, the program will end and a workout summary will be displayed. If the **Stop** button is pressed a third time, the console will return to the idle mode (start up) screen. If the **Stop** button is held down for more than 3 seconds the console will reset.

GRADE FEATURE

The New Grade function of Sole TT8 make user can be stay in decline condition, The Grade level from -6 ~ 15, When 1~15 level by red color, -1~-6 level by green color display.

- Grade may be adjusted anytime after belt movement.
- Press and hold the **Grade ▲/▼** keys (console or handgrip) to achieve desired level of effort. You may also choose a more rapid increase / decrease by selecting desired key, -4, -2, 2, 4, 6, 9 and 12 on the console (Grade).
- The **Grade Window** display will indicate grade position as adjustments are made.



DOT MATRIX CENTER DISPLAY

Eighteen columns of dots, 8 high for the TT8 indicate each segment of a workout. The dots are only to show an approximate level (speed/Grade) of effort. They do not necessarily indicate a specific value - only an approximate percent to compare levels of intensity. In operation, the speed/grade dot matrix window will build a profile "picture" as values are changed during a workout.

When the word "**Speed**" is lit above or below the dot matrix it indicates that the Speed profile is being displayed and when "**Grade**" is lit the Grade profile is being displayed.

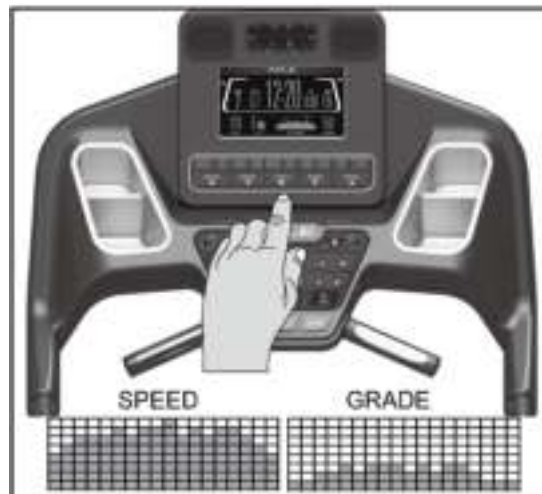

You may switch the speed or Grade dot matrix profile shown by pressing the **Enter** button. Pressing the **Enter** button a second time will switch it back to the previous profile. Pressing it a third time will automatically alternate the Speed and Grade profile views.



MESSAGE DISPLAY

When the display key is pressed, or when a program is ended, additional exercise information is displayed. The information includes: LAPS, Verticle (virtual altitude based on Grade setting), METs, Segment Time, Max Speed.

CALORIE DISPLAY

Displays the cumulative calories burned at any given time during your workout.

Note: *This is only a rough guide used for comparison of different exercise sessions, which cannot be used for medical purposes.*

There is an **Audio Input Jack** () on the front of the console and built-in speakers. You may plug any low-level audio source signal into this port. Audio sources include MP3, iPod, portable radio, CD player or even a TV or computer audio signal. There is an audio patch cable included to and also a headphone jack () for private listening.

PULSE FEATURE

The **Pulse (Heart Rate) Window** will display your current heart rate in beats per minute during the workout. You must use both stainless steel sensors on the front cross bar to display your pulse or wear the wireless chest strap. The pulse value will display anytime the upper display is receiving a pulse signal.



TURNING OFF TREADMILL

1. The display will automatically turn off – go to sleep - after 30 minutes of inactivity when in the Pause / Stop mode. Almost all power for the treadmill will be off except for some circuits that are needed to detect if any key is pressed, indicating the console should “wake up”. When the console is “asleep” the treadmill draws very little power, about as much as your television when it is turned off.
2. Removing the **safety key** is similar to entering “sleep” mode. Turning off the main power switch in the front of the treadmill will completely remove any power.

****ATTENTION****

Your new console comes configured in an in-store “display mode” of operation, where the console will remain powered on unless the main power switch is turned off. To exit the display mode, for normal operation, press and hold the **Stop**, **Enter** and **Display** keys for 5 seconds; the display will show: Display mode - On. Use any of the **Program**, **Grade** or **Speed ▲** keys to change the setting to Off then press **Enter**.

New Sole App to be used in conjunction with select Apple & Android devices!

In order to help you achieve your exercise goals, Sole has added an exciting new feature to this product. Your new exercise machine comes equipped with a Bluetooth® transceiver that will allow it to interact with selected phones or tablet computers via the Sole Fitness App.

Just download the free Sole Fitness App from the Apple Store or Google Play, and follow the instructions in the App to sync with your exercise machine. This allows you to view current workout data in three different Display screens on your device. You can easily switch back and forth from the workout display view to internet/social media/email sites via icons on the display screen. When

your workout is finished, the data is automatically saved to the built-in personal calendar for future reference.

Our new Sole Fitness App also allows you to sync your workout data to one of many fitness cloud sites we support: iHealth, MapMyFitness, Record or Fitbit.

Syncing the App with your exercise machine:

After downloading the App, make sure Bluetooth® is enabled on your device, then tap the icon in the top left corner to search for Sole equipment.



After the equipment is detected, tap Connect. When the App and equipment are synced, the Bluetooth® icon on the equipment's console will light up. You may now start using your new Sole product!

If the treadmill is not connected to the app, the console will display "SYNC" when the workout is over. You can then connect using your phone or tablet to store workout data in the App. The console can only store the last workout data. When the treadmill returns to IDLE MODE, workout data will be erased.

*Note: Your device will need to run on a minimum operating system of iOS 7 or Android 4.4 or above for the Sole Fitness App to operate properly.

The exercise equipment's Bluetooth device (BLE 4.0) can also be connected to the Bluetooth wireless heart rate chest strap transmitter (BLE 4.0). The chest strap transmitter can receive signals even when the App is already in use. In order to do such a functional switch, you need to use the heart rate key on the key board. Take the following steps to achieve this:

1. In idle mode, the heart rate Bluetooth LED on the keypad will not be lit if the Bluetooth function is currently connected with the App.
2. In idle mode, press the heart rate key on the keyboard. The Bluetooth LED will light on. This shows that the Bluetooth function is now switched to connect to the Bluetooth wireless heart rate chest strap. You can wear the Bluetooth wireless heart rate chest strap first then commence connection. While in connection, the console will show heart rate value via Bluetooth.
3. When the workout is over, the console will automatically switch its Bluetooth connection back to the previously connected App.

The exercise equipment can also play music wirelessly via Bluetooth. Turn on your mobile phone or tablet's Bluetooth function. Search for the name "Bt-speaker" in your device's Bluetooth menu. Tap to connect. Now your device can transmit music to the exercise equipment.

PROGRAMMABLE FEATURES

The TT8 have ten built-in programs: one Manual program, five preset profiles, one Custom, one Fitness Test, and two Heart Rate programs (HR1 & HR2).

PRESET PROGRAMS

Hill

The **Hill** program simulates going up and down a hill. The workload will steadily increase and then decrease during the program.

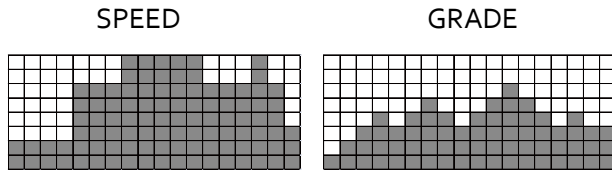

Fat Burn

The **Fat Burn** program is designed, as the name implies, to maximize the burning of fat. There are many schools of thought on the best way to burn fat but most experts agree that a lower exertion level that stays at a steady workload is the best. The absolute best way to burn fat is to keep your heart rate at around 60% to 70% of its maximum potential. This program does not use heart rate but simulates a lower, steady exertion workout.

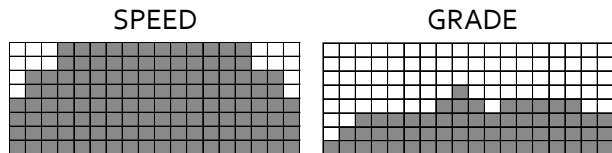

Cardio

The **Cardio** program is designed to increase your cardiovascular function and endurance. This is exercise for your heart and lungs. It will build up your heart muscle and increase blood flow and lung capacity. This is achieved by incorporating a higher level of exertion with slight fluctuations in work.

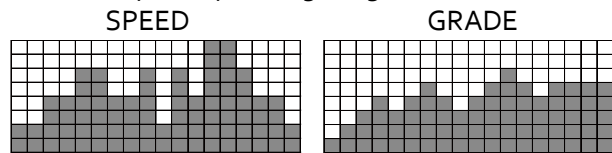

Strength

The **Strength** program is designed to increase muscular strength in your lower body. This program will steadily increase in workload to a high level and forces you to sustain it. This is designed to strengthen and tone your legs and glutes (muscles of the butt)

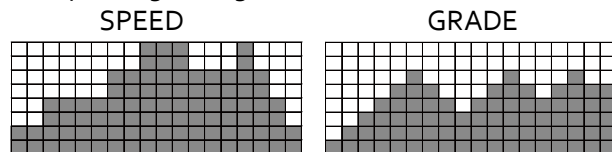

HIIT

The **HIIT** program takes you through high levels of intensity followed by periods of low intensity. This program increases your endurance by depleting your oxygen level followed by periods of recovery to replenish oxygen. Your cardiovascular system gets programmed to use oxygen more efficiently this way. This program also forces your body to become more efficient due to spikes in heart rate, between recovery periods. This aids in heart rate recovery from intense activities

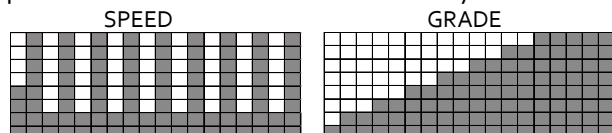

SELECTING A PROGRAM

1. Press the **Program** keys to view the programs on the screen, if you would like to perform. The display will prompt you through the programming steps or you can just press the **Start** key to begin the program using the preset program values for age, weight and other program specific information.



2. In the setting, the menu will display Age at first item. You may use any of the **Grade ▲/▼** or **Speed ▲/▼** keys to adjust your age. After adjusting press the **Enter** key.

Note: You may press **Start** at any time during the programming to start the program with the information you've already input.

3. The **Weight Window** will now be displaying a value, which is your **Body Weight**.

Entering the correct body weight will affect the calorie count. Use the **Grade ▲/▼** keys or the **Speed ▲/▼** to adjust, then press Enter.

■ **Calorie Display Note:** No exercise machine can give you an exact calorie count because there are too many factors which determine exact calorie burn for a particular person. Even if someone is the exact same body weight, age and height, their calorie burn may be very different than yours. The **Calorie** display is to be used as a reference only to monitor improvement from workout to workout.

4. The **Time Window** will now be displaying a value, which is total workout time desired. Use the **Grade ▲/▼** keys or the **Speed ▲/▼** keys to adjust, and then press **Enter**. After adjusting, press the **Enter** key.
5. The **Speed Window** will display the preset top speed of the selected program. Use the **Grade ▲/▼** keys or the **Speed ▲/▼** keys to adjust, and then press **Enter**. Each program has various speed changes throughout; this allows you to limit the highest speed the program will reach at its peak.
6. Press **Start** to begin the program. The program will begin with a 3 minute warm-up. If you want to bypass this and go directly to the beginning of the program, press **Start** again.



CUSTOM PROGRAMS

1. Select **CUSTOM** via the **Program** keys.

Note that the dot matrix display portion will have a single row of dots at the bottom (Unless there is a previously stored program). If there is a program stored under the button that is pressed, it will be retrieved. If not, you have the option of programming in your first name. The name **Message Window** will display and flash the letter "A". To change it, press the any **▲** key, then "B" will be displayed; if the any **▼** key is pressed, the letter "Z" will be displayed. After selecting the appropriate letter, press **STOP**. The letter "A" will again be displayed. Repeat the procedure until all letters of your first name are programmed (7 characters maximum). When your name is displayed, press **Enter** and it will be stored under CUSTOM.

2. Next the menu will be display Age window first. Use the **Grade ▲/▼** keys to adjust. Press **Enter**. This is a must to continue even if age is not adjusted.
3. The **Weight window** will now be display a body **Weight** value. Enter your body weight and press **Enter**.
4. The **Time Window** will now be display a **Time** value. Adjust the **Time** and press **Enter**.
5. The first column (segment) will now be blinking. Using the **Speed ▲/▼** or keys, adjust the speed level to your desired effort for the first segment then press **Enter**. The second column will now be blinking. Repeat the above process until all segments have been programmed. The first column will be blinking again. This is for the grade programming. Repeat the above process to program all segments for Grade.

Note: While in a User program, if you manually change the speed, all segment speeds from there on will also change.

Examples: If you increase your current speed 1 mph, the remaining segment speeds will increase by 1 mph. If you decrease your current speed .5 mph, the remaining segment speeds will decrease by .5 mph, etc.

6. Press the **Start** button to begin the workout and also save the program to memory.
7. The profile picture will be re-scaled to fit in the window, but the actual speed and grade settings will remain the same as programmed.

Charge Portable Devices with USB port

USB Port Charging function:

Charge your personal device during your workout using the fitness equipment's on-console USB port.

To charge your mobile electronics make sure the fitness equipment power is on.

Step 1: Connect your USB charging cable (not included) to the USB Power Port and to your device.

Step 2: Check to make sure your device icon indicates it is charging.

NOTE :

* USB charging cable is not included, make sure compatible USB charging cable is being used.

** Your device "charging" icon may or may not indicate it is charging. Depending on the amount of current your particular device requires for charging the icon may not be on but your device is still charging, but possibly at a lower charge rate.

***The USB port on the console is capable of powering USB devices. It provides up to 5Vdc/0.5 amp of power and meets USB 2.0 regulations. You will not be able to save your workout data to a USB via this

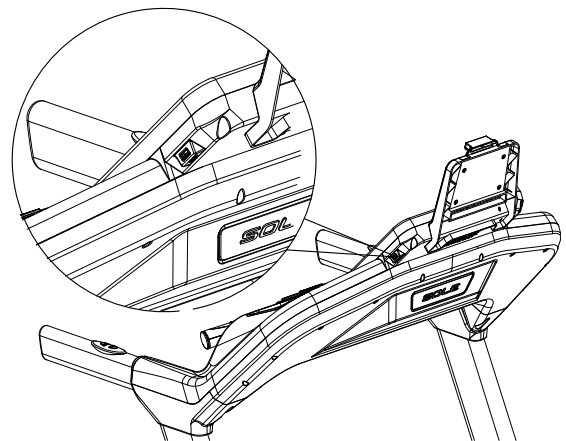

port; it is used for charging purposes only.

FITNESS TEST PROGRAM

The fit test program is designed to determine your estimated VO₂ max or how well your body utilizes oxygen. The test follows a progression in both speed and elevation and lasts a maximum of 11 minutes. If your actual heart rate reaches 85% of projected maximum before the end of the test, the program will end and your score will be based on the stage you ended at. The higher your estimated VO₂, the more fit you are.

Stage	Time	Speed	Grade	VO ₂ Max
1	0 to 1:00	4.5mph	0%	31.15
2.1	1:15	4.5mph	2%	32.55
2.2	1:30	4.5mph	2%	33.6
2.3	1:45	4.5mph	2%	34.65
2.4	2:00	4.5mph	2%	35.35
3.1	2:15	5.0mph	2%	37.45
3.2	2:30	5.0mph	2%	39.55
3.3	2:45	5.0mph	2%	41.3
3.4	3:00	5.0mph	2%	43.4
4.1	3:15	5.0mph	4%	44.1
4.2	3:30	5.0mph	4%	45.15
4.3	3:45	5.0mph	4%	46.2
4.4	4:00	5.0mph	4%	46.5
5.1	4:15	5.5mph	4%	48.6
5.2	4:30	5.5mph	4%	50
5.3	4:45	5.5mph	4%	51.4
5.4	5:00	5.5mph	4%	52.8
6.1	5:15	5.5mph	6%	53.9
6.2	5:30	5.5mph	6%	54.9
6.3	5:45	5.5mph	6%	56
6.4	6:00	5.5mph	6%	57
7.1	6:15	6.0mph	6%	57.7
7.2	6:30	6.0mph	6%	58.8
7.3	6:45	6.0mph	6%	60.2
7.4	7:00	6.0mph	6%	61.2
8.1	7:15	6.0mph	8%	62.3
8.2	7:30	6.0mph	8%	63.3
8.3	7:45	6.0mph	8%	64
8.4	8:00	6.0mph	8%	65
9.1	8:15	6.5mph	8%	66.5
9.2	8:30	6.5mph	8%	68.2
9.3	8:45	6.5mph	8%	69
9.4	9:00	6.5mph	8%	70.7
10.1	9:15	6.5mph	10%	72.1

10.2	9;30	6.5mph	10%	73.1
10.3	9;45	6.5mph	10%	73.8
10.4	10;00	6.5mph	10%	74.9
11.1	10;15	7.0mph	10%	76.3
11.2	10;30	7.0mph	10%	77.7
11.3	10;45	7.0mph	10%	79.1
11.4	11;00	7.0mph	10%	80

Fitness Test Programming

1. Press the Fit-test button and press **Enter**.
2. The Message Window will now be showing a value, indicating your Age. Use the **Grade ▲/▼** keys to adjust, and then press **Enter**.
3. The Message Window will now be showing a value, indicating your Body Weight. Use the **Grade ▲/▼** keys to adjust, and then press **Enter**.
4. The Message Window will display PRESS START TO BEGIN OR ENTER TO MODIFY

Before the test

- Make sure you are in good health; check with your physician before performing any exercise if you are over the age of 35 or persons with pre-existing health conditions.
- Make sure you have warmed up and stretched before taking the test.
- Do not take in caffeine before the test.
- Hold the hand grips gently, do not tense up.

During the test

- The console must be receiving a steady heart rate for the test to begin. You may use the hand pulse sensors or wear a heart rate chest strap transmitter.
 1. The test starts with a three minute warm-up. Speed will be set at 3 mph, grade at 0%. The Message Window will display 3 MINUTE WARM-UP and alternate every 5 seconds with actual HR888 & Target Heart Rate. The time window will start at three minutes and count down to zero. All other data windows will accrue.
 2. The speed and grade will follow the changes shown in the chart to the right.
 3. When the user reaches the target the test will continue for 15 seconds. A cool down period will start. The grade will be set to 0 percent. The speed will be 3.0 MPH. The cool down time will be based on the total time to complete the test. If the test took 5 min. or less, then the cool down is 1 minute. If the test took between 5 min. to 12 min., the cool down will be 3 minutes. The Message Window will display for 5 seconds: 1 (or 3 min) MIN COOL DOWN and alternate every 5 seconds with YOUR SCORE. The time window will start at 1 (or 3 min) minute and count down to zero.
 4. The score is taken from the table based on the final stage completed.

After the test

- Cool down for about one to three minutes.
- Take note of your score because the console will automatically return to the start-up mode after a few minutes.

What your score means:

VO₂max Chart for males and very fit females

	18-25 years old	26-35 years old	36-45 years old	46-55 years old	56-65 years old	65+ years old
Excellent	>60	>56	>51	>45	>41	>37
Good	52-60	49-56	43-51	39-45	36-41	33-37
Above average	47-51	43-48	39-42	35-38	32-35	29-32
Average	42-46	40-42	35-38	32-35	30-31	26-28
Below average	37-41	35-39	31-34	29-31	26-29	22-25
Poor	30-36	30-34	26-30	25-28	22-25	20-21
Very poor	<30	<30	<26	<25	<22	<20

VO₂max Chart for females and de-conditioned males

	18-25 years old	26-35 years old	36-45 years old	46-55 years old	56-65 years old	65+ years old
Excellent	56	52	45	40	37	32
Good	47-56	45-52	38-45	34-40	32-37	28-32
Above average	42-46	39-44	34-37	31-33	28-31	25-27
Average	38-41	35-38	31-33	28-30	25-27	22-24
Below average	33-37	31-34	27-30	25-27	22-24	19-22
Poor	28-32	26-30	22-26	20-24	18-21	17-18
Very poor	<28	<26	<22	<20	<18	<17

HEART RATE PROGRAMS

Before we get started, a word about Heart Rate:

The old motto, “no pain, no gain”, is a myth that has been overpowered by the benefits of exercising comfortably. A great deal of this success has been promoted by the use of heart rate monitors. With the proper use of a heart rate monitor, many people find that their usual choice of exercise intensity was either too high or too low and exercise is much more enjoyable by maintaining their heart rate in the desired benefit range.

To determine the benefit range in which you wish to train, you must first determine your Maximum Heart Rate. This can be accomplished by using the following formula: 220 minus your age. This will give you the Maximum Heart Rate (MHR) for someone of your age. To determine the effective heart rate range for specific goals you simply calculate a percentage your MHR. Your Heart rate training zone is 50% to 90% of your maximum heart rate. 60% of your MHR is the zone that burns fat while 80% is for strengthening the cardio vascular system. This 60% to 80% is the zone to stay in for maximum benefit.

For someone who is 40 years old their target heart rate zone is calculated:

$$\begin{aligned} 220 - 40 &= 180 \text{ (maximum heart rate)} \\ 180 \times .6 &= 108 \text{ beats per minute} \\ &\text{(60\% of maximum)} \\ 180 \times .8 &= 144 \text{ beats per minute} \\ &\text{(80\% of maximum)} \end{aligned}$$

So for a 40 year old the training zone would be 108 to 144 beats per minute.

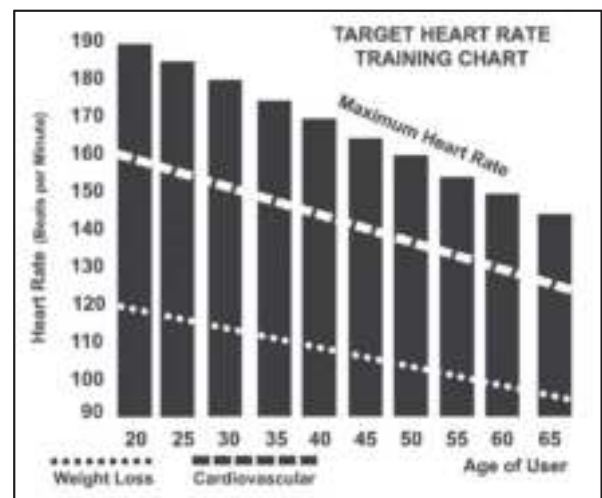

If you enter your age during programming the console will perform this calculation automatically. Entering your age is used for the Heart Rate programs. After calculating your MHR you can decide upon which goal you would like to pursue.

The two most popular reasons for, or goals, of exercise are cardiovascular fitness (training for the heart and lungs) and weight control. The black columns on the chart above represent the MHR for a person whose age is listed at the bottom of each column. The training heart rate, for either cardiovascular fitness or weight loss, is represented by two different lines that cut diagonally through the chart. A definition of the lines' goal is in the bottom left-hand corner of the chart. If your goal is cardiovascular fitness or if it is weight loss, it can be achieved by training at 80% or 60%, respectively, of your MHR on a schedule approved by your physician. Consult your physician before participating in any exercise program.

RATE OF PERCEIVED EXERTION

Heart rate is important but listening to your body also has a lot of advantages. There are more variables involved in how hard you should workout than just heart rate. Your stress level, physical health, emotional health, temperature, humidity, the time of day, the last time you ate and what you ate, all contribute to the intensity at which you should workout. If you listen to your body, it will tell you all of these things.

The rate of perceived exertion (RPE), also known as the Borg scale, was developed by Swedish physiologist G.A.V. Borg. This scale rates exercise intensity from 6 to 20 depending upon how you feel or the perception of your effort.

The scale is as follows:

Rating Perception of Effort

- 6 Minimal
- 7 Very,very light
- 8 Very,very light +
- 9 Very light
- 10 Very light +
- 11 Fairly light
- 12 Comfortable
- 13 Somewhat hard
- 14 Somewhat hard +
- 15 Hard
- 16 Hard +
- 17 Very hard
- 18 Very hard +
- 19 Very,very hard
- 20 Maximal

You can get an approximate heart rate level for each rating by simply adding a zero to each rating. For example a rating of 12 will result in an approximate heart rate of 120 beats per minute. Your RPE will vary depending up the factors discussed earlier. That is the major benefit of this type of training. If your body is strong and rested, you will feel strong and your pace will feel easier. When your body is in this condition, you are able to train harder and the RPE will support this. If you are feeling tired and sluggish, it is because your body needs a break. In this condition, your pace will feel harder. Again, this will show up in your RPE and you will train at the proper level for that day.

USING HEART RATE TRANSMITTER

How to wear your wireless chest strap transmitter:

1. Attach the transmitter to the elastic strap using the locking parts.
2. Adjust the strap as tightly as possible as long as the strap is not too tight to remain comfortable.
3. Position the transmitter with the SOLE logo centered in the middle of your body facing away from your chest (some people must position the transmitter slightly left of center). Attach the final end of the elastic strap by inserting the round end and, using the locking parts, secure the transmitter and strap around your chest.
4. Position the transmitter immediately below the pectoral muscles.
5. Sweat is the best conductor to measure very minute heart beat electrical signals. However, plain water can also be used to pre-wet the electrodes (2 ribbed oval areas on the reverse side of the belt and both sides of the transmitter). It's also recommended that you wear the transmitter strap a few minutes before your work out. Some users, because of body chemistry, have a more difficult time in achieving a strong, steady signal at the beginning. After "warming up", this problem lessens. As noted, wearing clothing over the transmitter/strap doesn't affect performance.
6. Your workout must be within range - distance between transmitter/receiver – to achieve a strong steady signal. The length of range may vary somewhat but generally stay close enough to the console to maintain good, strong, reliable readings. Wearing the transmitter immediately against bare skin assures you of proper operation. If you wish, you may wear the transmitter over a shirt. To do so, moisten the areas of the shirt that the electrodes will rest upon.

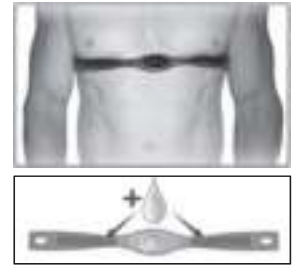

Note: The transmitter is automatically activated when it detects activity from the user's heart. Additionally, it automatically deactivates when it does not receive any activity. Although the transmitter is water resistant, moisture can have the effect of creating false signals, so you should take precautions to completely dry the transmitter after use to prolong battery life (estimated transmitter battery life is 2500 hours). The replacement battery is Panasonic CR2032.

ERRATIC OPERATION

Caution! Do not use this treadmill for Heart Rate unless a steady, solid Actual Heart Rate value is being displayed. High, wild, random numbers being displayed indicate a problem.

Areas to look for interference which may cause erratic heart rate:

1. Microwave ovens, TV's, small appliances, etc.
2. Fluorescent lights.
3. Some household security systems.
4. Perimeter fence for a pet.
5. Some people have problems with the transmitter picking up a signal from their skin. If you have problems try wearing the transmitter upside down. Normally the transmitter will be oriented so the SOLE logo is right side up.
6. The antenna that picks up your heart rate is very sensitive. If there is an outside noise source, turning the whole machine 90 degrees may de-tune the interference.
7. Loose treadmill console or bolts in the upright tube.
8. Another Individual wearing a transmitter within 3' of your machine's console.

If you continue to experience problems, contact your dealer.

WARNING! - DO NOT USE THE HEART RATE PROGRAM IF YOUR HEART RATE IS NOT REGISTERING PROPERLY ON THE TREADMILL'S DISPLAY!

HEART RATE CONTROL PROGRAMMING

CAUTION!

Heart Rate programs are intended for wireless transmitter chest strap. Do not use **Pulse Grip** bar for **Heart Rate**. You must receive a strong/steady value in the **Heart Rate Window** (See Using Heart Rate Transmitter section for instructions on how to use).

The **HR1** program has a default level that is 60% of your projected heart rate maximum. This program is geared for individuals with fat loss as a goal. The **HR2** program has a default of 80% of your projected heart rate maximum. It is geared for individuals with a goal of improving cardiovascular & lung function.

1. Select **HR1** or **HR2** via the **Program** keys.
2. The **Age Window** will now be display showing user's age. Adjust and press **Enter** or press **Enter** to accept the default value. Adjusting **Age** will change the Target HR value.
3. The **Weight Window** will be displaying a value, showing the default user's bodyweight for this program. You may adjust it and press **Enter** if you want or just press **Enter** to accept the default value.
4. The Time Window will now be displaying a value. Adjust the time and press Enter.
5. Now you are asked to adjust the **HR1** or **HR2** value. The default is 60% (**HR1**); $(220 - \text{age} \times .60)$; or 80% (**HR2**); $(220 - \text{age} \times .80)$. You may select a higher or lower number also. Adjust the number by pressing the **Speed ▲/▼** keys (console or handrails) and press **Enter** to continue.
6. Now you are finished editing the settings and can begin your workout by pressing the **Start** key. You can also go back and modify your settings by pressing the **Stop** key to go back one level, or screen.
7. If you want to increase or decrease the speed at any time during the program press the **Speed ▲/▼** (console or handrail) keys.
8. During the HR program you will be able to show the data in the data window by pressing the Display key. When the program ends the **data Window** will show a summary of your workout. The summary will be displayed for a short time then the console will return to the start-up display.
9. Press **Start** to begin program.

The program will now control the treadmill Grade to steadily increase your heart rate to the target value. This process is automatic and could take upwards of five minutes, depending on how far your HR needs to go and what kind of physical shape you are in. People who are more fit will take longer to reach the target. You can make manual adjustments to the speed throughout the program.

GENERAL MAINTENANCE

BELT & DECK

Your treadmill uses a very high-efficient low-friction deck. Performance is maximized when the deck is kept as clean as possible. Use a soft, damp cloth, or paper towel, wipe the edge of the belt and the area between the belt edge and the frame. Also reach as far as practical directly under the belt edge. This should be done once a month to extend belt and bed life. A mild soap and water solution along with a nylon scrub brush will clean the top of the textured belt. **Allow to dry before using.**

BELT DUST

This occurs during normal break-in or until the belt stabilizes. Sometimes the black dust from the belt will appear on the floor behind the treadmill, this is normal.

GENERAL CLEANING (Use the chart on Pg. 5 to record your maintenance)

Dirt, dust, and hair can block air inlets and accumulate on the running belt. Please vacuum underneath your treadmill on a monthly basis to prevent excess build-up of dirt that can get sucked up and get into the inner workings under the motor cover. Every other month, you should remove the motor cover and carefully vacuum out dirt and hair that may accumulate. **UNPLUG THE POWER CORD BEFORE THIS TASK.**

BELT ADJUSTMENTS

Tread-belt Tension Adjustment - Belt tension is not critical for most users. It is very important though for joggers and runners in order to provide a smooth, steady running surface. Adjustment must be made from the rear roller with the M6 L Allen wrench (**105**) provided in the parts package. The adjustment bolts are located at the end of the step rails as shown in the diagram below. **Note:** *Adjustment is through small hole in end cap.*

Tighten the rear roller only enough to prevent slippage at the front roller. Turn the tread-belt tension adjusting bolts 1/4 turn each and inspect for proper tension by walking on the belt and making sure it is not slipping or hesitating with each step. When an adjustment is made to the belt tension, you must be sure to turn the bolts on both sides evenly or the belt could start tracking to one side instead of running in the middle of the deck.

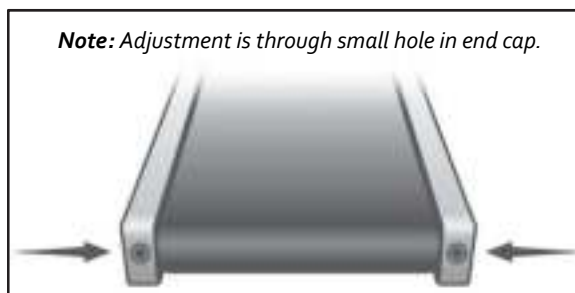

DO NOT OVERTIGHTEN – Over tightening will cause belt damage and premature bearing failure. If you tighten the belt a lot and it still slips, the problem could actually be the drive belt - located under the motor cover - that connects the motor to the front roller. If that belt is loose it feels similar to the walking belt being loose. Tightening the motor belt should be done by a trained service person.

TREAD-BELT TRACKING ADJUSTMENT

The treadmill is designed so that the tread-belt remains reasonably centered while in use. It is normal for some belts to drift near one side while in use, depending on a user's gait and if they favor one leg. But if during use the belt continues to move toward one side, adjustments are necessary.

SETTING TREAD-BELT TRACKING

A 6 mm Allen wrench (105) is provided for this adjustment. Make tracking adjustments on the left side bolt. Set belt speed at 3 mph. Be aware that a small adjustment can make a dramatic difference which may not be apparent right away. If the belt is **too close to the left side**, then turn the bolt only a 1/4 turn to the right (clockwise) and wait a few minutes for the belt to adjust itself.

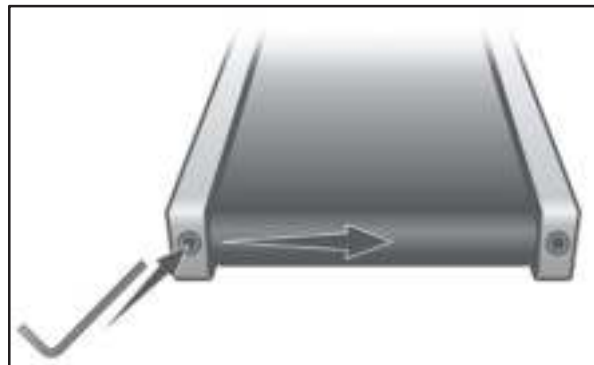

Continue to make 1/4 turns until the belt stabilizes in the center of the running deck. If the belt is **too close to the right side**, turn the bolt counter-clockwise. The belt may require periodic tracking adjustment depending on use and walking/running characteristics. Some users may affect tracking differently. Expect to make adjustments as required to center the tread-belt. Adjustments will become less of a maintenance concern as the belt is used. Proper belt tracking is an owner responsibility common with all treadmills.

ATTENTION:

DAMAGE TO THE RUNNING BELT RESULTING FROM IMPROPER TRACKING / TENSION ADJUSTMENTS IS NOT COVERED UNDER THE SOLE WARRANTY.

TREADMILL BELT

The walking belt on your new Sole treadmill is made of the highest quality materials designed to last even under punishing conditions. When a treadmill belt is brand new, and has been in the package for a few months before use, a common occurrence can happen; the area of the belt that wraps around the rollers will take on the shape of the roller. Upon starting the treadmill this shape in the belt causes a thumping sound each time the belt moves past the rollers. Once the treadmill has been used for a few workouts, the belt wears in and the thumping sound goes away. This noise is normal on new higher end belts so there is no need to contact service; the new belt just requires a wear in period. Thank you for choosing Sole and enjoy your new treadmill.

DECK MAINTENANCE

The deck has a wax coating that generally withstands up to 20,000 miles of use on the original side. If either of these two scenarios continues to occur: belt stops very quickly after the safety key is dislodged or the 15 amp fuse continues to blow, you may have an issue with the wax between the belt and the deck. Follow this procedure in order:

1. Clean under the belt as described above under General Maintenance
2. Check the belt to make sure the tension isn't too tight; adjust as necessary
3. Call your service provider to have the deck flipped if it is on the original side. The other side will have a fresh wax coating.

SERVICE CHECKLIST - DIAGNOSIS GUIDE

Before contacting your dealer for aid, please review the following information. It may save you both time and expense. This list includes common problems that may not be covered under the treadmill's warranty.

PROBLEM	SOLUTION/CAUSE
<p>Display does not light</p>	<ol style="list-style-type: none"> 1. Tether cord not in position. 2. Circuit breaker on front grill tripped. Push circuit breaker in until it locks. 3. Plug is disconnected. Make sure plug is firmly pushed into AC household wall outlet. 4. Household circuit breaker may be tripped. 5. Treadmill defect. Contact your SOLE dealer.
<p>Tread-belt does not stay centered Treadmill belt hesitates when walked/run on</p>	<p>The user may be walking while favoring or putting more weight on either the left or right foot. If this walking pattern is natural, track the belt slightly off-center to the side opposite from the belt movement. See General Maintenance section on Tread-belt Tension. Adjust as necessary.</p>
<p>Motor is not responsive after pressing Start</p>	<ol style="list-style-type: none"> 1. If the belt moves, but stops after a short time and the display shows "E1", run calibration. 2. If you press Start and the belt never moves, then the display shows "E1", contact service.
<p>Treadmill will only achieve approximately 7 mph but shows higher speed on display</p>	<p>This indicates motor should be receiving power to operate. Low AC voltage to treadmill. Do not use an extension cord. If an extension cord is required it should be as short as possible and heavy duty 14 gauge minimum. Low household voltage. Contact an electrician or your SOLE dealer. A minimum of 110 volt AC current is required.</p>
<p>Tread-belt stops quickly/suddenly when tether cord is pulled</p>	<p>High belt/deck friction. See General Maintenance section on lubrication.</p>
<p>Treadmill trips on board 15 amp circuit</p>	<p>High belt/deck friction. See General Maintenance</p>
<p>Computer shuts off when console is touched (on a cold day) while walking/running</p>	<p>Treadmill may not be grounded. Static electricity is "crashing" the computer. Refer to Grounding Instructions on page 3.</p>
<p>House circuit breaker trips, but not the treadmill circuit breaker</p>	<p>Need to replace the house breaker with a "High In-rush current" type breaker (see page 3 for details)</p>

CALIBRATION PROCEDURE

1. Remove the **Safety Key**.
2. Press and hold down the **Start** and **Speed ▲** buttons and replace the **Safety Key**. Continue to hold the **Start** and **Speed ▲** key until the window displays "CALIBRATION MODE".
3. You will now be able to set the display to show Metric or English settings (Miles vs. Kilometers). To do this, press the **Grade ▲/▼** key to show which you want.
4. Grade return – On (This allows the grade to return to zero when **Stop** is pressed. For sale in Europe, EU standards require this to be off).
5. Press **Start** to begin calibration. The process is automatic; the speed will start up without warning, so do not stand on the belt.

MAINTENANCE MENU

1. Press and hold the **Start**, **Stop** and **Enter** key at the same time and install safety key, until the display shows "Engineering Mode" (it may say maintenance menu, depending on version). Press the **Enter** key.
2. You can now scroll through the menu using the **Speed ▲/▼** keys. Use the **Stop** key to return to previous menu selection. The menu selections are:
 - A. **KEY TEST** - Will allow you to test all the keys to make sure they are functioning
 - B. **Display Mode** - Turn off to have the console power down automatically after 30 minutes of inactivity
 - C. **Pause Mode** - Turned on to allow 5 minutes of pause, turn off to have console pause in definitely.
 - D. **LUBE MESSAGE RESET**
 - E. **Key Tone** - Will turn on/off beeping noise that is made when keys are pressed.
 - F. **CHILD LOCK** - Allows you to lock the keypad so no unauthorized use of the machine is allowed. When the Child lock is enabled, the console will not allow the keypad to operate unless you press and hold the **Start** and **Enter** buttons for 3 seconds to unlock the console.

EXPLODED VIEW DIAGRAM

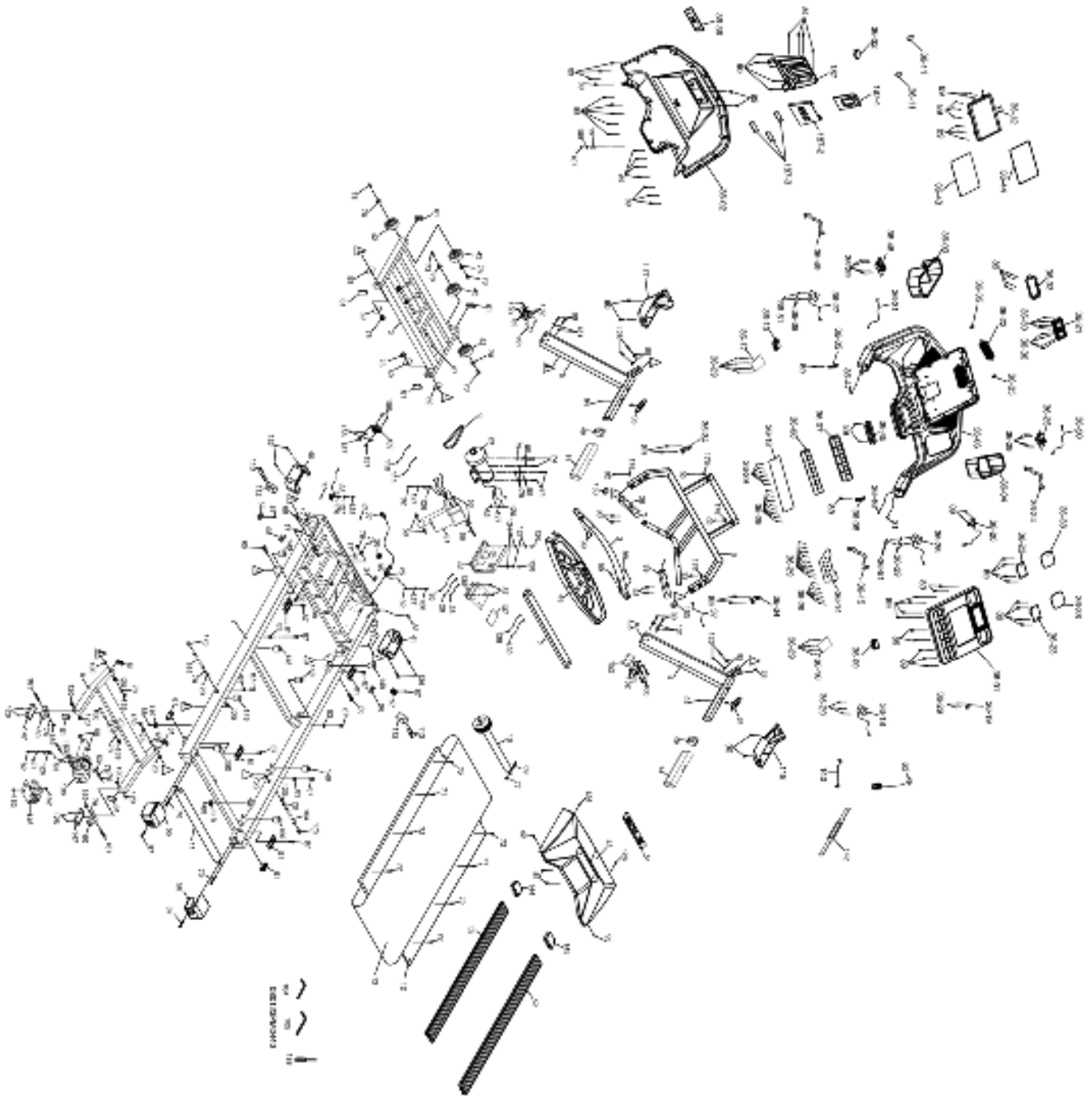

PARTS LIST

Key	Part	Part Description	Q'ty
1	9008801	Main Frame	1
2	9008802	Incline Bracket	1
3	9008803	Handrail Support	1
4	9008804	Right Upright	1
5	9008805	Left Upright	1
6	9008806	Console Support	1
7	9008807	Deck Cross Brace	1
8	9008808	Rear Incline Bracket	1
9	9008809	Drive Belt	1
10	9008810	Front Roller W/Pulley	1
11	9008811	Rear Roller	1
12	9008812	Running Deck	1
13	9008813	Running Belt	1
14	9008814	PVC Handgrip	2
17	9008817	Locking Pin Bracket	7
19	9008819	Safety Key Sleeve	1
20	9008820	Drive Motor	1
21	9008821	Incline Motor	1
22	9008822	Motor Controller	1
23	9008823	1200m/m_Sensor W/Cable	1
24	9008824	Breaker	1
25	9008825	Power Socket	1
26	9008826	On/Off Switch	1
27	9008827	Power Cord	1
28	9008828	100m/m_Connecting Wire (Black)	1
29	9008829	350m/m_Connecting Wire (White)	1
30	9008830	350m/m_Connecting Wire (Black)	1
31	9008831	800m/m_Computer Cable (Upper)	1
32	9008832	600m/m_Computer Cable(Lower)	1
33	9008833	1250m/m_Computer Cable(Middle)	1
34	9008834	300m/m_Speed Adjustment Switch W/Cable	1
35	9008835	300m/m_Incline Adjustment Switch W/Cable	1
36	9008836	Console Assembly	1
36-46	9008836-46	Upper Speed Cable	1
36-47	9008836-47	Upper Incline Cable	
37	9008837	150m/m_Handpulse Wire	1
38	9008838	400m/m_Handpulse W/Cable Assembly(L)	1
39	9008839	400m/m_Handpulse W/Cable Assembly(R)	1
40	9008840	Frame Base Cover (L)	1
41	9008841	Frame Base Cover (R)	1
42	9008842	Transportation Wheel	4
43	9008843	Motor Top Cover	1

Key	Part	Part Description	Q'ty
48	9008848	Beverage Holder	1
49	9008849	Handgrip End Cap	2
51	9008851	Top Motor Cover Plate	1
52	9008852	Aluminum Foot Rail	2
53	9008853	Ø10 × Ø25 × 0.8T_Nylon Washer	4
55	9008855	Adjustment Base (L)	1
56	9008856	Adjustment Base (R)	1
57	9008857	Motor Cover Anchor(D)	2
58	9008858	Ø25 × Ø10 × 3T_Nylon Washer (A)	4
59	9008859	Ø50 × Ø13 × 3T_Nylon Washer (B)	4
60	9008860	Foot Pad Bracket	2
61	9008861	25m/m × 50m/m_Square End Cap	10
63	9008863	Trapezoidal Safety Key	1
65	9008865	1/2" × 2-1/2" _Socket Head Cap Bolt	2
66	9008866	3/8" × 1-3/4" _Socket Head Cap Bolt (Alloy Steel)	1
67	9008867	3/8" × 4" _Socket Head Cap Bolt (Alloy Steel)	1
68	9008868	3/8" × 1-1/2" _Hex Head Bolt	2
69	9008869	M8 × 60m/m_Hex Head Bolt	1
70	9008870	M8 × 80m/m_Socket Head Cap Bolt (Alloy Steel)	2
71	9008871	M8 × 55m/m_Flat Head Countersink Bolt	2
72	9008872	M8 × 35m/m_Flat Head Countersink Bolt	6
73	9008873	3/8" × 3/4" _Button Head Socket Bolt	4
74	9008874	3/8" × 1-1/4" _Hex Head Bolt	4
75	9008875	1/2" × 15T_Nylon Nut	2
76	9008876	3/8" × 7T_Nylon Nut	3
77	9008877	M8 × 7T_Nylon Nut	1
78	9008878	Ø3/8" × Ø19 × 1.5T_Flat Washer	14
79	9008879	Ø3/8" × Ø25 × 2.0T_Flat Washer	4
81	9008881	Ø5.5 × 27 × 60 × 1.5T × 3H_Concave Washer	4
82	9008882	M5_Star Washer	4
83	9008883	Ø5 × Ø25 × 1.5T × 4.94H_Concave Washer	4
85	9008885	Ø10 × 2.0T_Split Washer	14
87	9008887	Ø5 × 16m/m_Tapping Screw	14
88	9008888	5 × 19m/m_Tapping Screw	2
89	9008889	3.5 × 12m/m_Sheet Metal Screw	65
90	9008890	3.5 × 16m/m_Sheet Metal Screw	8
92	9008892	5 × 16m/m_Tapping Screw	6
93	9008893	3 × 10m/m_Tapping Screw	4
94	9008894	4 × 50m/m_Sheet Metal Screw	2
95	9008895	3 × 10m/m_Sheet Metal Screw	2
96	9008896	20m/m × 40m/m_Square End Cap	2
98	9008898	3/8" × 7T_Nut	2
99	9008899	5/16" × 3/4" _Flat Head Socket Bolt	8
100	90088100	3/8" × 2-1/4" _Button Head Socket Bolt	6

Key	Part	Part Description	Q'ty
102	90088102	Ø3/8" × Ø19 × 1.5T_Flat Washer	6
104	90088104	Allen Wrench	1
105	90088105	M6_L Allen Wrench	1
107	90088107	Ø4 × 56m/m_Sheet Metal Screw	1
109	90088109	Fan	1
110	90088110	400m/m_Motor Fan Connecting Cable-Black	1
111	90088111	400m/m_Motor Fan Connecting Cable-White	1
112	90088112	Fixing Plate Stabilizer	2
113	90088113	3/8" × 2-1/4" _Flat Head Socket Bolt	4
117	80088117	Console Mast Cover(L)	1
118	90088118	Console Mast Cover(R)	1
119	90088119	Rubber Foot Pad	2
120	90088120	Bushing	12
125	90088125	3/8" × 1-3/4" _Button Head Socket Bolt	4
126	90088126	M5 × 10m/m_Phillips Head Screw	15
127	90088127	Ø5 × 1.5T_Split Washer	7
128	90088128	M5 × 20m/m_Phillips Head Screw	2
131	90088131	Ø8 × 23 × 1.5T_Curved Washer	4
134	90088134	Ø5 × Ø12 × 1.0T_Flat Washer	2
135	90088135	Controller Plate	1
136	90088136	Incline Motor	1
137	90088137	Rear Incline Controller	1
138	90088138	300m/m_Connecting Wire (White)	1
139	90088139	300m/m_Connecting Wire (Black)	1
140	90088140	400m/m_Audio Cable	1
144	90088144	Foot Rail Cap (L)	1
145	90088145	Foot Rail Cap (R)	1
146	90088146	Incline Motor Cover	1
147	90088147	Foot Pad	2
148	90088148	M8 × Ø30 × 37L_Cushion(Gray)	2
149	90088149	M8 × Ø30 × 37L_Cushion (Green)	4
150	90088150	M8 × Ø30 × 37L_Cushion (Black)	2
151	90088151	Bracket (L)	1
152	90088152	Bracket (R)	1
153	90088153	Handpulse End Cap	2
156	90088156	M4 × P0.7 × 35L_Phillips Head Screw	2
157	90088157	M4 × P0.7 × 5T_Nylon Nut	2
158	90088158	Ø4 × Ø10 × 1.0T_Flat Washer	2
159	90088159	M10 × 8T_Nylon Nut	5
160	90088160	M10 × 65m/m_Socket Head Cap Bolt	1
161	90088161	M10 × P1.5 × 50L_Button Head Socket Bolt	2
162	90088162	4 × 6m/m_Phillips Head Trilobular Screw	2

Key	Part	Part Description	Q'ty
163	90088163	3/8" × UNC16 × 1-1/2" _Socket Head Cap Bolt	1
164	90088164	M10 × 110m/m_Hex Head Bolt	2
175	90088175	Ø17m/m_Bolt Cap	2
176	90088176	Ø1/4" × Ø19 × 1.5T_Flat Washer	5
187	90088187	Tablet Holder	1
187-1	90088187-1	Tablet Holder Plate	1
187-2	90088187-2	Tablet Holder Front Cover	1
187-3	90088187-3	Foam Stop, Handlebar Eye Tube	3
188	90088188	Phillips Head Screwdriver	1
189	90088189	Ø5 × Ø15 × 1T_Flat Washer	1

TREADMILL WARRANTY

Dyaco Canada Inc. warrants all its Sole treadmills' parts, for a period of time listed below, from the date of retail sale, as determined by sale receipt. Dyaco Canada Inc.'s responsibilities include providing new or remanufactured parts, at Dyaco Canada Inc.'s option, and technical support to our independent dealers and servicing organizations. In the absence of a dealer or service organization, these warranties will be administered by Dyaco Canada Inc. directly to a consumer. The warranty period applies to the following components:

Residential		Light Commercial	
Drive Motor	Lifetime	Drive Motor	5 Years
All Other Components	5 Years	All other Components	3 Years
Frame Weldments	Lifetime	Frame Weldments	Lifetime
Labour	2 Years	Labour	1 Year
Cosmetic Items*	90 Days	Cosmetic Items*	90 Days

*Cosmetic items including, but not limited to the following: grips, console overlays, and labels/decals

NORMAL RESPONSIBILITIES OF THE CONSUMER

This warranty applies only to products in ordinary household use, and the consumer is responsible for the items listed below:

1. The warranty registration card must be completed and returned to the address listed on the card within 10 days of the original purchase to validate the manufacturer's limited warranty.
2. Proper use of the treadmill in accordance with the instructions provided in this manual, including belt tracking.
3. Proper installation in accordance with instructions provided with the treadmill and with all local electric codes.
4. Proper connection to a grounded power supply of sufficient voltage, replacement of blown fuses, repair of loose connections or defects in house wiring.
5. Expenses for making the treadmill accessible for servicing, including any item that was not part of the treadmill at the time it was shipped from the factory.
6. Damages to the treadmill finish during shipping, installation or following installation.
7. Routine maintenance of this unit as specified in this manual.

EXCLUSIONS

This warranty does not cover the following:

1. CONSEQUENTIAL, COLLATERAL, OR INCIDENTAL DAMAGES SUCH AS PROPERTY DAMAGE AND INCIDENTAL EXPENSES RESULTING FROM ANY BREACH OF THIS WRITTEN OR ANY IMPLIED WARRANTY.
Note: Some areas do not allow the exclusion or limitation of incidental or consequential damages, so this limitation or exclusion may not apply to you.
2. Service call reimbursement to the consumer. Service call reimbursement to the dealer that does not involve malfunction or defects in workmanship or material, for units that are beyond the warranty period, for units that are beyond the service call reimbursement period, for treadmill not requiring component replacement, or treadmill not in ordinary household use.
3. Damages caused by services performed by persons other than authorized Dyaco Canada Inc. service companies; use of parts other than original Dyaco Canada Inc. parts; or external causes such as corrosion, discoloration of paint or plastic, alterations, modifications, abuse, misuse, accident, improper maintenance, inadequate power supply, or acts of God.
4. Products with original serial numbers that have been removed or altered.
5. Products that have been: sold, transferred, bartered, or given to a third party.
6. Products that do not have a warranty registration card on file at Dyaco Canada Inc. Dyaco Canada Inc. reserves the right to request proof of purchase if no warranty record exists for the product.
7. THIS WARRANTY IS EXPRESSLY IN LIEU OF ALL OTHER WARRANTIES EXPRESSED OR IMPLIED, INCLUDING THE WARRANTIES OF MERCHANTABILITY AND/OR FITNESS FOR A PARTICULAR PURPOSE.
8. Product use in any environment other than a residential setting.
9. Warranties outside of North America may vary. Please contact your local dealer for details.

SERVICE

Keep your bill of sale. The labour period is twelve (12) months or twenty four (24) months from the date on the bill of sale. If service is performed, it is in your best interest to obtain and keep all receipts. This written warranty gives you specific legal rights. You may also have other rights that vary in different areas. Service under this

warranty must be obtained by following these steps, in order:

1. Contact your selling authorized SOLE dealer.
2. If you have any questions about your new product or questions about the warranty contact Dyaco Canada Inc. at 1-888-707-1880.
3. If no local service is available, Dyaco Canada Inc. will repair the parts, at Dyaco Canada Inc.'s option, within the warranty period at no charge for parts. All transportation costs, both to our factory and upon return to the owner, are the responsibility of the owner. The owner is responsible for adequate packaging upon return to Dyaco Canada Inc. Dyaco Canada Inc. is not responsible for damages that occur during shipping. Make all freight damage claims with the appropriate freight carrier. DO NOT SHIP ANY UNIT TO OUR FACTORY WITHOUT A RETURN AUTHORIZATION NUMBER. All units arriving without a return authorization number will be refused.
4. For any further information, or to contact our service department by mail, send your correspondence to:

Dyaco Canada Inc.
5955 Don Murie Street
Niagara Falls, ON
L2G 0A9

Product features or specifications as described or illustrated are subject to change without notice. All warranties are made by Dyaco Canada Inc.



Please visit us online for information about our other brands and products manufactured and distributed by Dyaco Canada Inc.



www.dyaco.ca



www.dyaco.ca



www.dyaco.ca



www.dyaco.ca



www.spiritfitness.ca
www.dyaco.ca



www.spiritfitness.ca
www.dyaco.ca



www.solefitness.ca
www.dyaco.ca



www.trainorsports.ca
www.dyaco.ca



www.xterrafitness.ca
www.dyaco.ca

Customer Service 1-888-707-1880
Email: customerservice@dyaco.ca

SOLE
FITNESS

