



Liebert®

GXT5™ UPS

Installer/User Guide

200 V to 240 V, 5,000 VA to 20,000 VA

The information contained in this document is subject to change without notice and may not be suitable for all applications. While every precaution has been taken to ensure the accuracy and completeness of this document, Vertiv assumes no responsibility and disclaims all liability for damages resulting from use of this information or for any errors or omissions. Refer to other local practices or building codes as applicable for the correct methods, tools, and materials to be used in performing procedures not specifically described in this document.

The products covered by this instruction manual are manufactured and/or sold by Vertiv. This document is the property of Vertiv and contains confidential and proprietary information owned by Vertiv. Any copying, use or disclosure of it without the written permission of Vertiv is strictly prohibited.

Names of companies and products are trademarks or registered trademarks of the respective companies. Any questions regarding usage of trademark names should be directed to the original manufacturer.

Technical Support Site

If you encounter any installation or operational issues with your product, check the pertinent section of this manual to see if the issue can be resolved by following outlined procedures. Visit <https://www.VertivCo.com/en-us/support/> for additional assistance.

TABLE OF CONTENTS

Important Safety Information	1
1 GXT5 Description	3
1.1 UPS Features and Available Models	3
1.2 Front Panels	4
1.3 Rear Panels	4
1.4 Removable Power-distribution Boxes	10
1.5 Internal Battery Packs	12
1.6 Major Internal Components and Operating Principle	13
1.6.1 Maintenance Bypass	14
1.7 UPS States and Operating Modes	14
1.7.1 Normal Mode	14
1.7.2 Bypass Mode	15
1.7.3 Battery Mode	16
1.7.4 ECO Mode	17
1.7.5 Maintenance Bypass Mode	18
2 Installation	21
2.1 Unpacking and Inspection	21
2.2 Pre-installation Preparation	21
2.2.1 Installation Clearances	21
2.3 Installing the UPS	22
2.3.1 Tower Installation	22
2.3.2 Rack Installation	22
2.4 Installing External Battery Cabinets	23
2.5 Installing a Power-distribution Box	24
2.6 Hardwired Input/Output Connections	25
2.6.1 Branch Circuit Breaker	26
2.6.2 Terminal-block Connections	27
2.6.3 Connecting to Terminal Blocks on 5-kVA and 6-kVA models	29
2.6.4 Connecting to Terminal Blocks on 8-kVA and 10-kVA models	29
2.6.5 Connecting to Terminal Blocks on 16-kVA and 20-kVA models	30
2.7 Communication Connections	32
2.7.1 Connecting IntelliSlot Communication	32
2.7.2 Connecting to the Dry-contact Port	32
2.7.3 Connecting a Remote Emergency Power-off (REPO) Switch	33
2.7.4 Connecting a USB Cable	34
2.7.5 Connecting CLI Communication Cables	35
2.7.6 Connecting Sensors to the Control Port	35
2.8 Installing a Parallel System	35
2.8.1 First-time Start-up of Parallel System	37
2.8.2 Commissioning Parallel System	37

2.8.3 Adding a Single UPS to the Parallel System	38
3 Operating the UPS	39
3.1 Silencing the Audible Alarm	39
3.2 Starting-up the UPS	39
3.3 Transferring to Battery Mode	39
3.4 Transferring from Normal to Bypass Mode	40
3.5 Transferring from Bypass to Normal Mode	40
3.6 Shutting-down the UPS Completely	40
3.7 Remote Emergency Power-off (REPO)	40
4 Operation and Display Panel	41
4.1 LED Indicators	42
4.2 LCD Menu and Screens	43
4.2.1 Start-up and Flow Screens	43
4.2.2 Main Menu	43
4.3 Editing Display and Operation Settings	51
4.3.1 Changing the Password	51
4.3.2 Selecting the Display Language	52
4.3.3 Setting the Date and Time	52
5 Maintenance	53
5.1 Replacing Batteries	53
5.2 Charging Batteries	55
5.3 Checking UPS Operation	56
5.4 Cleaning the UPS	56
5.5 Removing the Power-distribution Box	56
6 Troubleshooting	59
6.1 Symptoms that Require Troubleshooting	59
6.2 Audible Alarm (Buzzer)	59
6.2.1 Faults	59
6.3 Troubleshooting UPS Issues	60
7 Specifications	61
7.1 Battery Run Times	69
Appendices	73
Appendix A: Technical Support	73

IMPORTANT SAFETY INFORMATION

IMPORTANT! This manual contains important safety instructions that must be followed during the installation and maintenance of the UPS and batteries. Read this manual thoroughly and the safety and regulatory information, available at <https://www.vertivco.com/ComplianceRegulatoryInfo>, before attempting to install, connect to supply, or operate this UPS.

This page intentionally left blank

1 GXT5 DESCRIPTION

The Liebert® GXT5 is a compact, online uninterruptible power system (UPS) that continuously conditions and regulates its output voltage. The Liebert® GXT5 supplies microcomputers and other sensitive equipment with clean sine-wave input power.

Upon generation, AC power is clean and stable. However, during transmission and distribution it is subject to voltage sags, spikes, and complete failure that may interrupt computer operations, cause data loss, and damage equipment.

The Liebert® GXT5 protects equipment from these disturbances. The Liebert® GXT5 continuously charges its batteries from the mains, enabling it to supply power to connected loads, even when the mains fail.

1.1 UPS Features and Available Models

The GXT5 includes the following features. **Table 1.1** on the next page, lists the available models and power ratings.

- Enhanced load capacity with an output power factor of 1.
- Optional tower or rack installation to meet varying installation requirements.
- Parallel-connection capability for 10-kVA, 16-kVA, and 20-kVA models achieves up to 2 + 1 parallel redundant power.
- Adapts to areas with unstable power-mains supply via high-frequency double-conversion topology structure, with high input-power factor, wide input-voltage range, and output immune to grid interference.
- Full digital-control platform and hardware-design platform adapts to unstable mains supply and load impact
- Programmable terminals with cascade protection on 5-kVA to 10-kVA models protect key devices when load is heavy.
- Innovative design layout and process greatly increase product reliability.
- Operation and display panel with model-specific color LCD offers simple configuration and control of the UPS.
- ECO power-supply mode and smart-sleep mode help you save the maximum amount of energy.

Table 1.1 UPS Models and Power Ratings

MODEL NUMBER	NOMINAL POWER RATING
GXT5-5000IRT5UXLN	5 kVA/5 kW
GXT5-5000IRT5UXLE	
GXT5-5000HVRT5UXLN	
GXT5-6000IRT5UXLN	6 kVA/6 kW
GXT5-6000IRT5UXLE	
GXT5-8000IRT5UXLN	8 kVA/8 kW
GXT5-8000IRT5UXLE	
GXT5-8000HVRT5UXLN	

**Table 1.1 UPS Models and Power Ratings
(continued)**

MODEL NUMBER	NOMINAL POWER RATING
GXT5-10KIRT5UXLN	10 kVA/10 kW
GXT5-10KIRT5UXLE	
GXT5-10KHVRT5UXLN	
GXT5-16KIRT9UXLN	16 kVA/16 kW
GXT5-16KIRT9UXLE	
GXT5-20KIRT9UXLN	20 kVA/20 kW
GXT5-20KIRT9UXLE	

1.2 Front Panels

The various GXT5 models have the same general appearance, with the main difference being the receptacle types on the rear panel. **Figure 1.1** below, shows the 5-kVA to 10-kVA model in a tower and a rack configuration. When mounted in a rack, the 5- to 10-kVA units are turned 90 degrees. The orientation of the 16-kVA to 20-kVA models is the same in a rack or tower configuration.

Figure 1.1 Front View

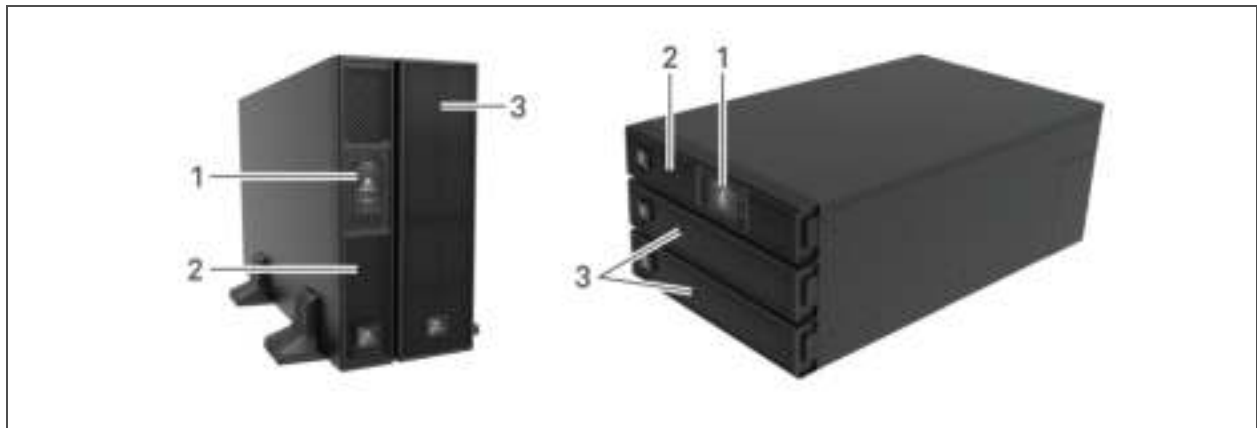

ITEM	DESCRIPTION
1	Operation/Display panel
2	Upper bezel
3	Lower bezel/battery-access door

1.3 Rear Panels

The following figures detail the rear-panel features for each GXT5 model.

Figure 1.2 GXT5-5000/6000IRT5UXLN (XLE) Rear Panel

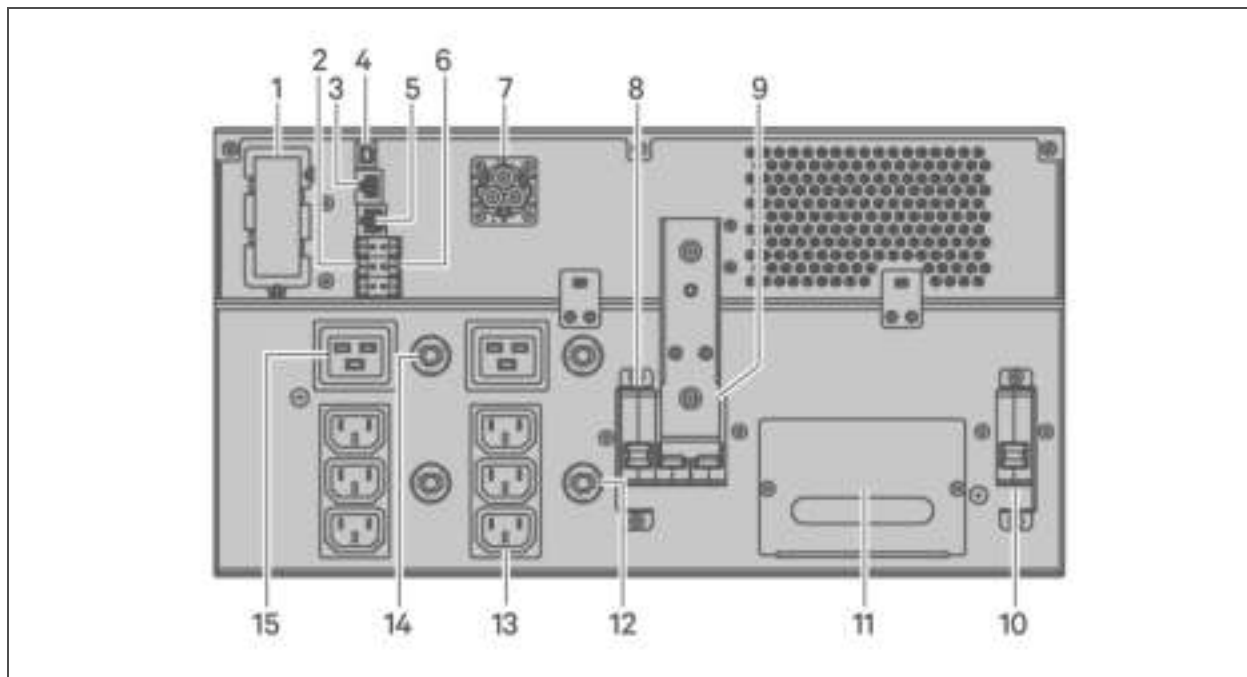

ITEM	DESCRIPTION
1	Liebert® IntelliSlot™ port
2	Terminal-block communication connectors
3	RS-485 port
4	USB port
5	RS-232 port
6	REPO connector
7	External-battery-cabinet connector
8	Output circuit breaker
9	Maintenance-bypass breaker
10	Input circuit breaker
11	Removable POD with cable-entry for hard-wire I/O
12	Overload protector, 10-A (x2)
13	Programmable C13 output receptacles (x2)
14	Overload protector, 15-A (x2)
15	C19 output receptacles (x2)

Figure 1.3 GXT5-5000HVRT5UXLN Rear Panel

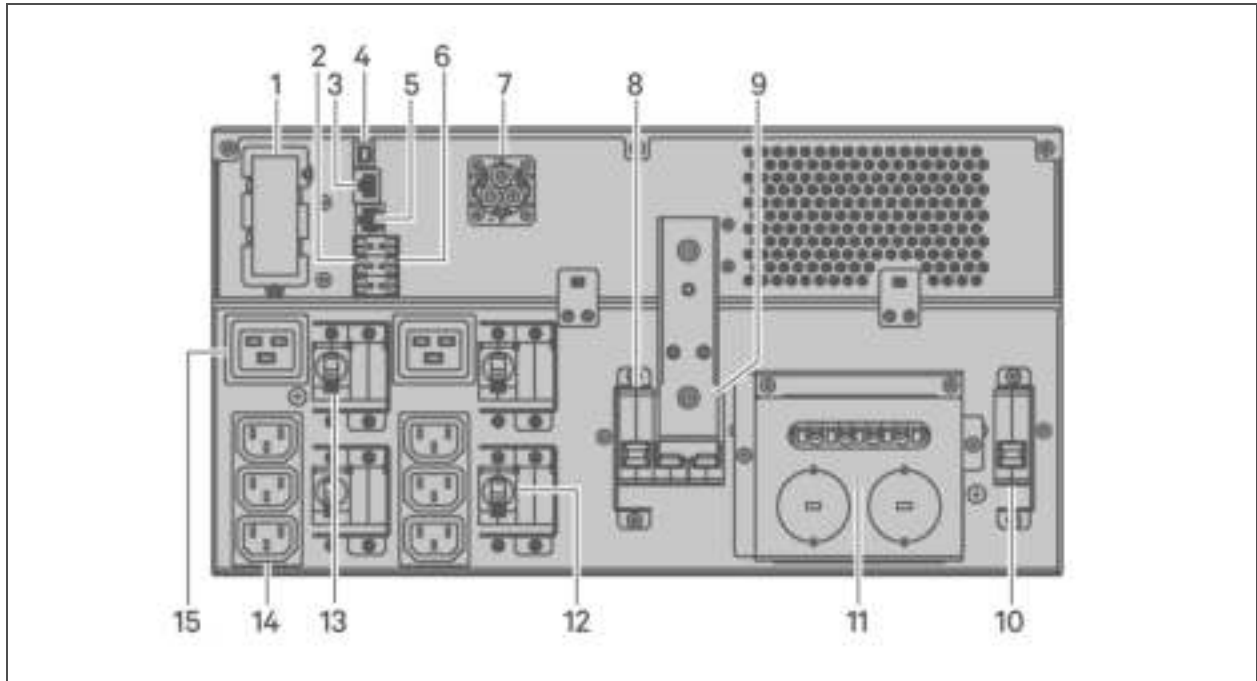

ITEM	DESCRIPTION
1	Liebert® IntelliSlot™ port
2	Terminal-block communication connectors
3	RS-485 port
4	USB port
5	RS-232 port
6	REPO connector
7	External-battery-cabinet connector
8	Output circuit breaker
9	Maintenance-bypass breaker
10	Input circuit breaker
11	Removable POD with knock-outs/cable-entry for hard-wire I/O
12	Programmable output circuit breaker, 10-A (x2)
13	C19 output circuit breaker
14	Programmable C13 output receptacles (x2)
15	C19 output receptacles (x2)

Figure 1.4 GXT5-8000/10KIRT5UXLN (XLE) Rear Panel

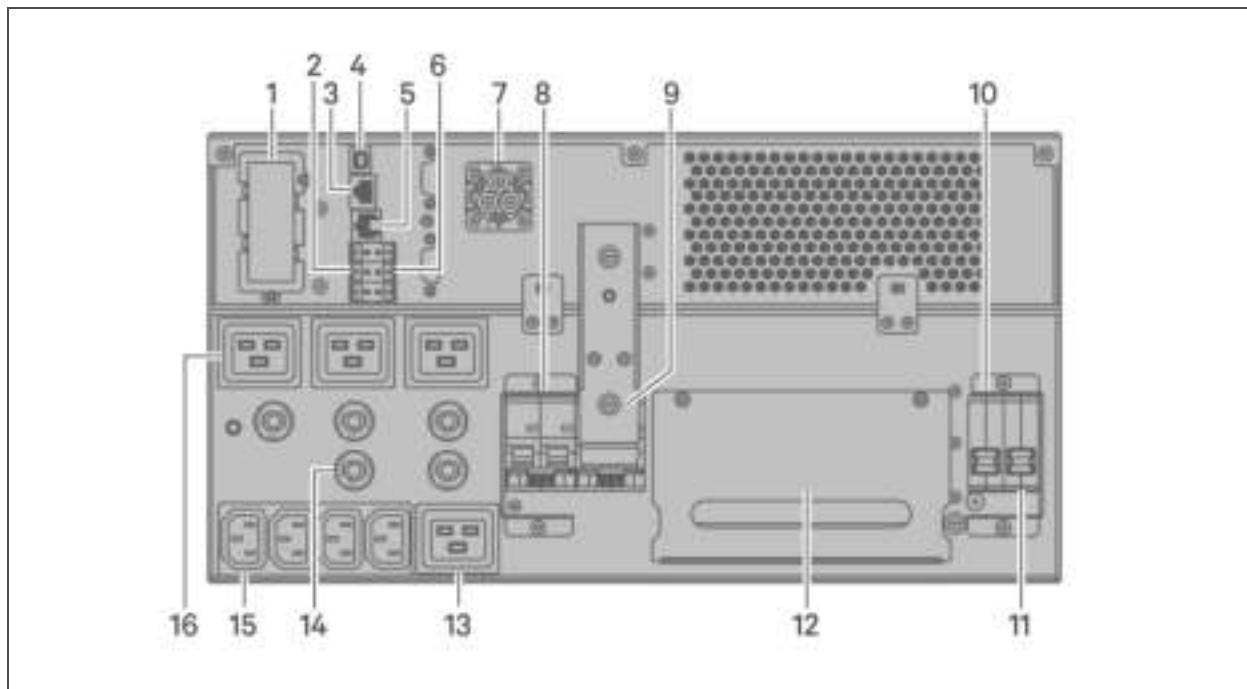

ITEM	DESCRIPTION
1	Liebert® IntelliSlot™ port
2	Terminal-block communication connectors
3	RS-485 port
4	USB port
5	RS-232 port
6	REPO connector
7	External-battery-cabinet connector
8	Output circuit breaker
9	Maintenance-bypass breaker
10	Bypass circuit breaker
11	Input circuit breaker
12	Removable POD with cable-entry for hard-wire I/O
13	Programmable C19 output receptacle
14	Overload protector, 10-A
15	Programmable C13 output receptacles
16	Overload protector, 15-A (x4)

Figure 1.5 GXT5-8000/10KHVRT5UXLN Rear Panel

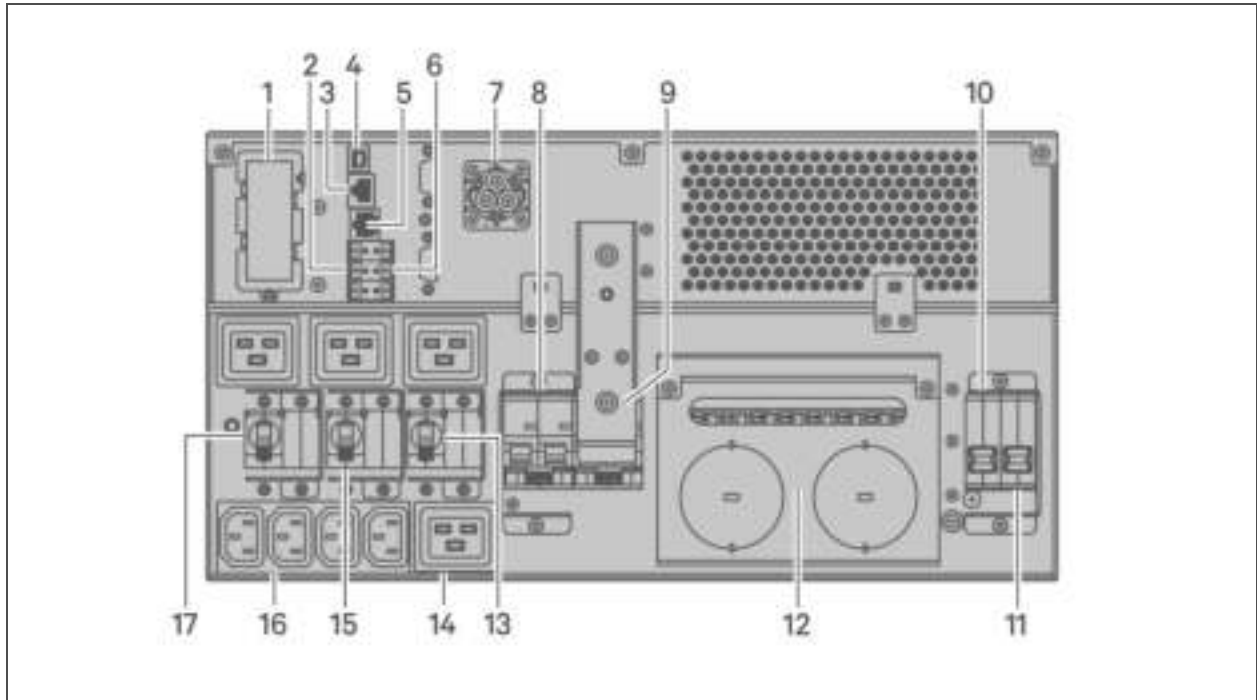

ITEM	DESCRIPTION
1	Liebert® IntelliSlot™ port
2	Terminal-block communication connectors
3	RS-485 port
4	USB port
5	RS-232 port
6	REPO connector
7	External-battery-cabinet connector
8	Output circuit breaker
9	Maintenance-bypass breaker
10	Bypass circuit breaker
11	Input circuit breaker
12	Removable POD with knock-outs/cable-entry for hard-wire I/O
13	Programmable output circuit breaker, 15-A
14	Programmable C19 output receptacle
15	Programmable output circuit breaker, 10-A
16	Programmable C13 output receptacles
17	C19 output circuit breaker, 15-A

Figure 1.6 GXT5-16K/20KIRT9UXLN (XLE) Rear Panel

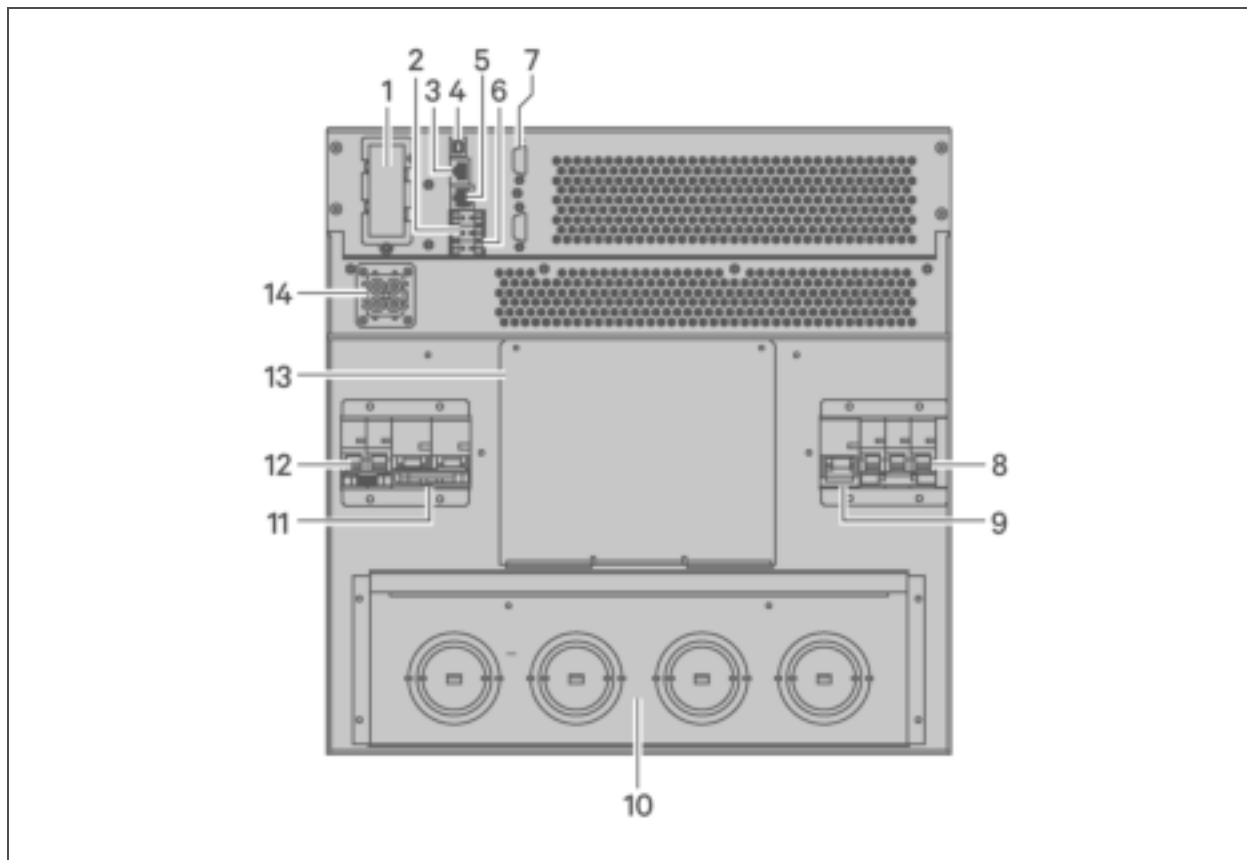

ITEM	DESCRIPTION
1	Liebert® IntelliSlot™ port
2	Terminal-block communication connectors
3	RS-485 port
4	USB port
5	RS-232 port
6	REPO connector
7	DB9 ports (parallel communication)
8	Input circuit breaker
9	Bypass circuit breaker
10	Knock-outs/cable-entry for hard-wire I/O
11	Output circuit breaker
12	POD breaker
13	Cover for optional POD-installation location
14	External-battery-cabinet connector

1.4 Removable Power-distribution Boxes

The 16-kVA and 20-kVA do not ship with an installed power-distribution box (POD). The optional PODs for the 16-kVA and 20-kVA models are:

- PD2-108 for models ending in "N" only (North America)
- PD2-200
- PD2-201
- PD2-202
- PD2-204 for models ending in "E" only (European Union)

The 5-kVA to 10-kVA models ship with the POD installed. This POD includes the input circuit breaker for the UPS, and the features for each POD are detailed in the following figures.

Figure 1.7 PD5-CE6HDWRMBS for GXT5-5000/6000IRT5UXLN (XLE)

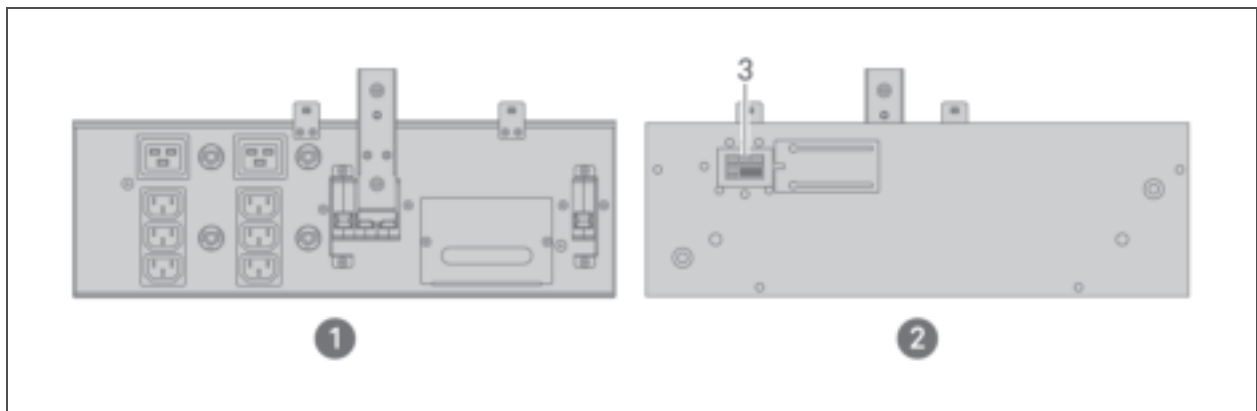

ITEM	DESCRIPTION
1	POD Panel view (on rear of unit)
2	POD inner-surface view
3	Quick connect

Figure 1.8 PD5-CE6HDWRMBSU for GXT5-5000HVRT5UXLN

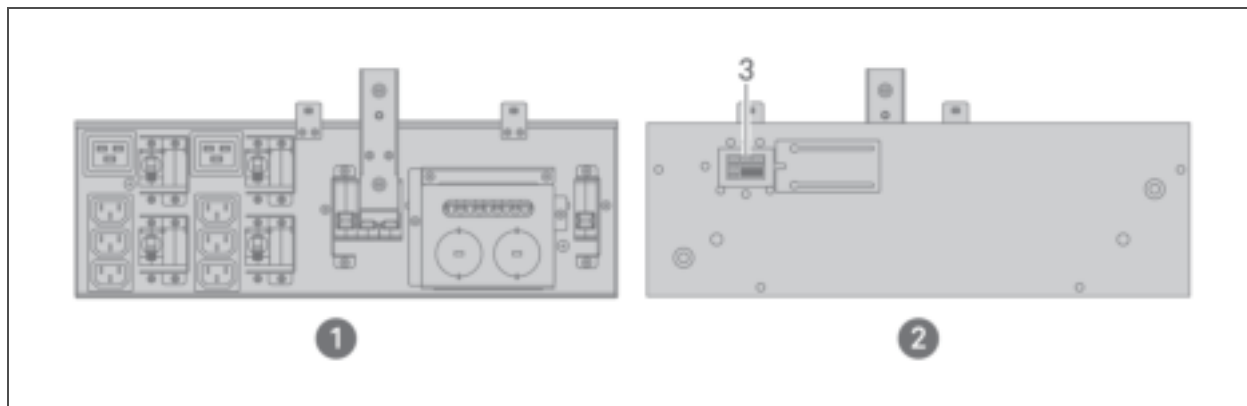

ITEM	DESCRIPTION
1	POD Panel view (on rear of unit)
2	POD inner-surface view
3	Quick connect

Figure 1.9 PD5-CE10HDWRMBS for GXT5-8000/10KIRT5UXLN (XLE)

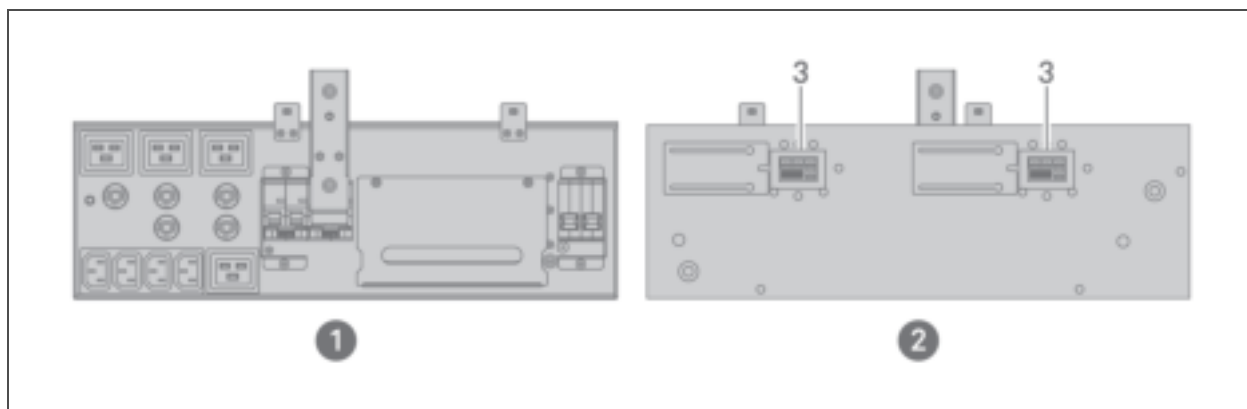

ITEM	DESCRIPTION
1	POD Panel view (on rear of unit)
2	POD inner-surface view
3	Quick connect

Figure 1.10 PD5-CE10HDWRMBSU for GXT5-8000/10KHVRT5UXLN

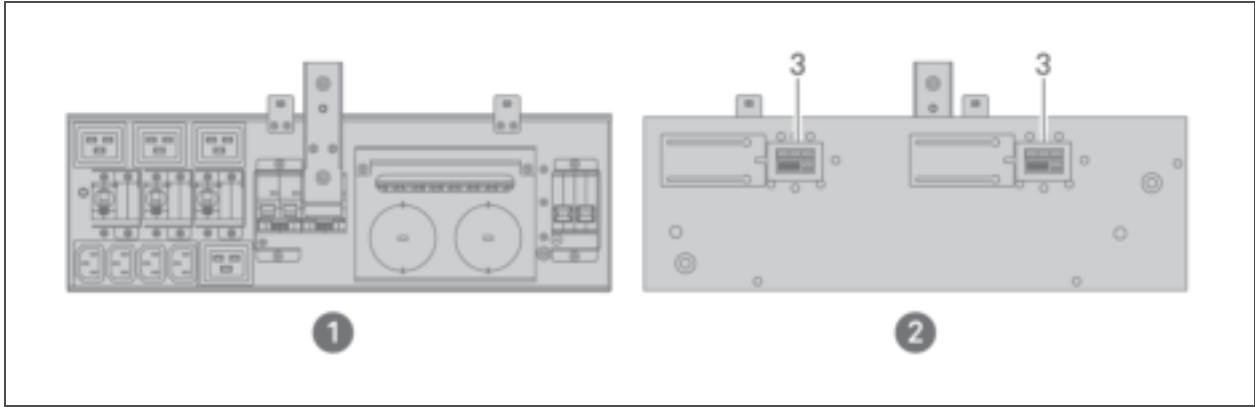

ITEM	DESCRIPTION
1	POD Panel view (on rear of unit)
2	POD inner-surface view
3	Quick connect

1.5 Internal Battery Packs

The internal battery packs for all GXT5 models, shown in **Figure 1.11** below, are located behind the access door on the front of the UPS. 5-kVA to 10-kVA units have 2 battery packs, and 16-kVA to 20-kVA units have 4 battery packs.

Figure 1.11 Internal Battery Pack

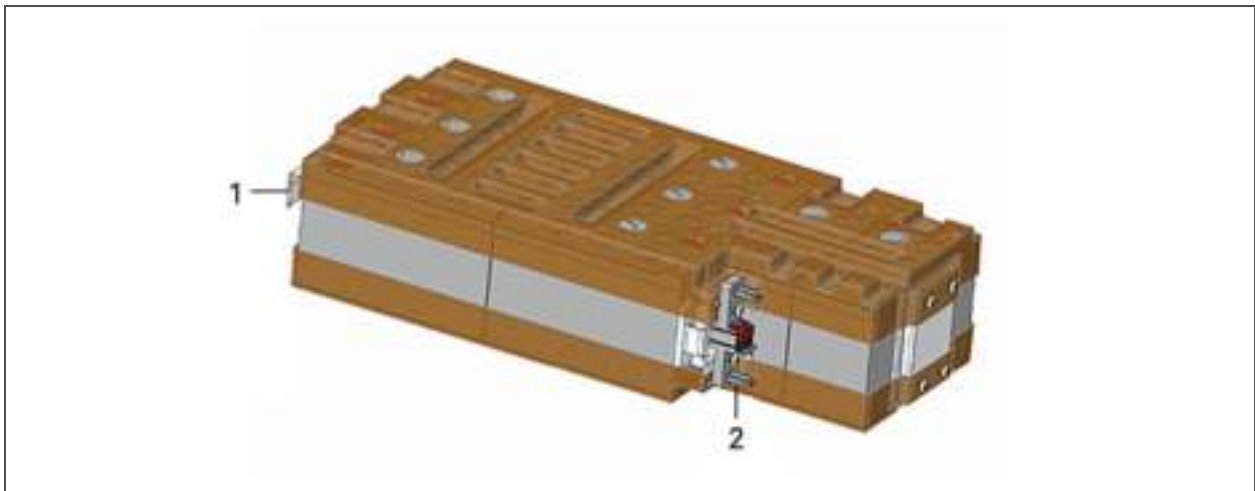

ITEM	DESCRIPTION
1	Handle
2	Connector

1.6 Major Internal Components and Operating Principle

Figure 1.12 below, shows the UPS operating principle. Table 1.2 on the next page, describes the function of the major components in the UPS.

NOTE: Figure 1.12 below, is one example of basic operation. The actual I/O connections for the various models may be divided into different types. See [Hardwired Input/Output Connections](#) on page 25.

Figure 1.12 Basic Operating Principle Diagram

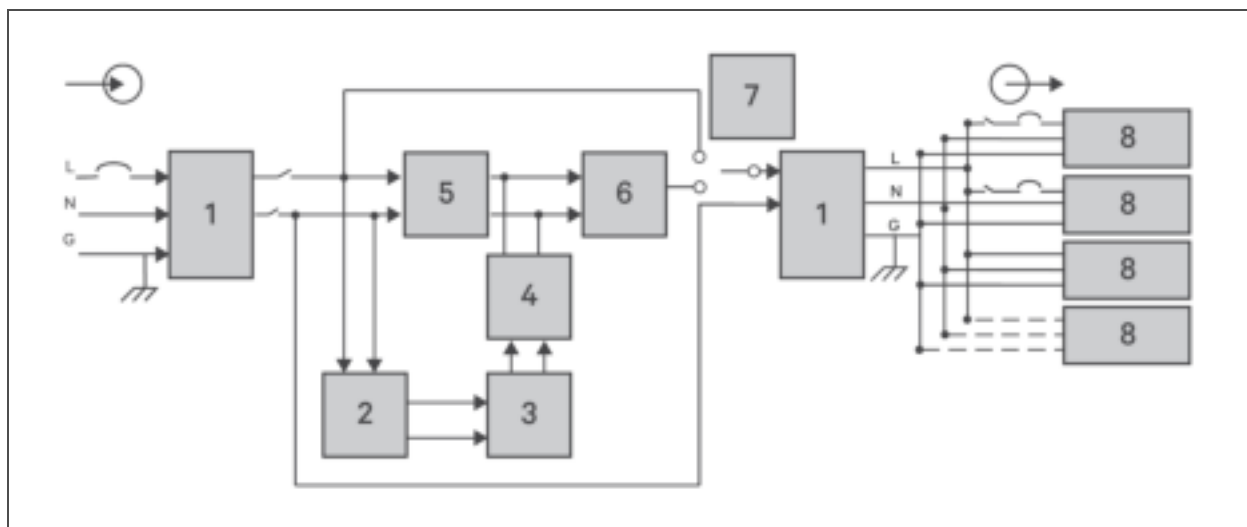

Table 1.2 Major Components

ITEM	COMPONENT	OPERATION/FUNCTION
1	Transient Voltage Surge Suppression (TVSS) and EMI/RFI Filters	Provide surge protection. Filter electromagnetic interference (EMI) and radio frequency interference (RFI). Minimize surges or interference present in the utility power and protect devices connected on the same branch as the UPS.
2	Battery Charger	Continuously float-charges the batteries from precisely-regulated utility power whenever the UPS is plugged in.
3	Batteries	Valve-regulated, non-spillable, lead-acid batteries. NOTE: To maintain battery design life, operate the UPS in an ambient temperature of 59°F to 77°F (15°C to 25°C).
4	DC-to-DC Converter	Raises the DC voltage from the battery to the optimum operating voltage for the inverter. This allows the inverter to operate continuously at its optimum efficiency and voltage, thus increasing reliability.
5	Rectifier/Power Factor Correction (PFC) Circuit	In normal operation, converts utility AC power to regulated DC power for use by the inverter while ensuring that the wave shape of the input current used by the UPS is near ideal. Extracting this sine-wave input current ensures efficient use of utility power and reduces reflected harmonic distortion making cleaner power available to devices that are not protected by the UPS.

Table 1.2 Major Components (continued)

ITEM	COMPONENT	OPERATION/FUNCTION
6	Inverter	In normal operation, inverts the DC output of the PFC circuit into precise, regulated sine-wave AC power. When utility power fails, the inverter receives DC power from the DC-to-DC converter. In either operating mode, the UPS inverter remains on-line, generating clean, precise, regulated AC-output power.
7	Internal Bypass	In the unlikely event of UPS failure such as overload or over-temperature, automatically transfers the connected load to bypass. To manually transfer the connected load from inverter to bypass, see Transferring from Normal to Bypass Mode on page 40.
8	Outlet group	Output receptacles.

1.6.1 Maintenance Bypass

On 5-kVA to 10-kVA models, the UPS includes manual maintenance bypass in a removable section of the rear of the UPS. Maintenance bypass keeps connected equipment powered with utility power and allows replacement of the UPS in the event of a UPS malfunction.

NOTE: The bypass power path does not protect the connected equipment from disturbances in the utility power supply.

1.7 UPS States and Operating Modes

NOTE: See [LED Indicators](#) on page 42, for description of the run-indicator and alarm-indicator LEDs mentioned in this section.

1.7.1 Normal Mode

When utility power is normal, Normal mode employs the rectifier and inverter to provide voltage- and frequency-stabilized power to the load. The charger charges the battery in normal mode. On the front-panel display, the run-indicator (green) is On, the alarm indicator is OFF, and the buzzer is silent. **Figure 1.13** on the facing page, shows a diagram of normal mode.

Figure 1.13 Normal-mode Operation

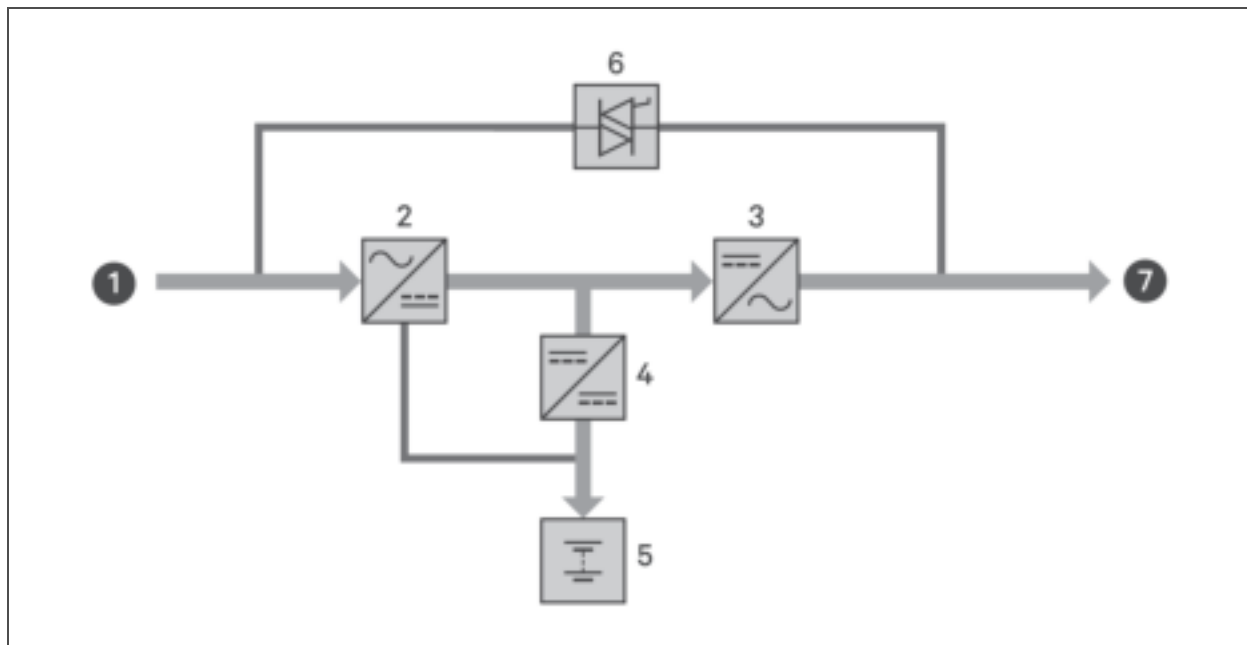

ITEM	DESCRIPTION
1	Mains/Utility input (by-pass input)
2	Rectifier/PFC
3	Inverter
4	Battery charger
5	Battery
6	Bypass static switch
7	UPS output

1.7.2 Bypass Mode

Bypass mode supplies power to the load from the bypass source (utility power) if an overload or fault occurs during normal operation. On the front-panel display, the run indicator (green) is On, the alarm indicator (yellow) is On, and the buzzer beeps once each seconds. The LCD "Current" screen displays "On Bypass." **Figure 1.14** on the next page, shows a diagram of bypass mode.

NOTE: If utility power fails or if the utility voltage goes outside of the permissible range during bypass-mode operation, the UPS shuts down and no output is supplied to the load.

Figure 1.14 Bypass-mode Operation

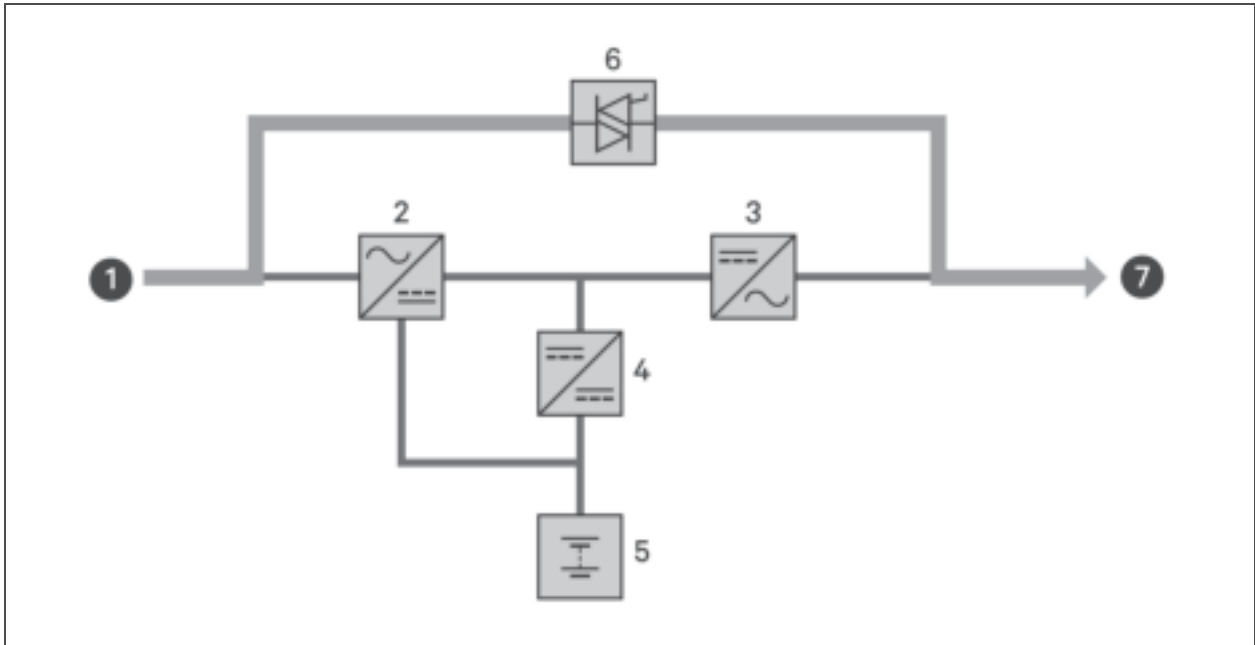

ITEM	DESCRIPTION
1	Mains/Utility input (by-pass input)
2	Rectifier/PFC
3	Inverter
4	Battery charger
5	Battery
6	Bypass static switch
7	UPS output

1.7.3 Battery Mode

Battery mode supplies battery power to the load if utility power fails or if the utility voltage goes outside of the permissible range. On the front-panel display, the run indicator (green) is On, the alarm indicator (yellow) is On, and the buzzer beeps once each second. The LCD "Current" screen displays "On Battery." Figure 1.15 on the facing page, shows a diagram of battery mode.

NOTE: The batteries are fully-charged before shipment. However, transportation and storage inevitably cause some loss of capacity. To ensure adequate back-up time, charge the batteries for at least 8 hours before first start-up.

NOTE: If utility power fails and the batteries are charged, you may cold-start the UPS in battery mode and use battery power to extend system availability for a time.

Figure 1.15 Battery-mode Operation

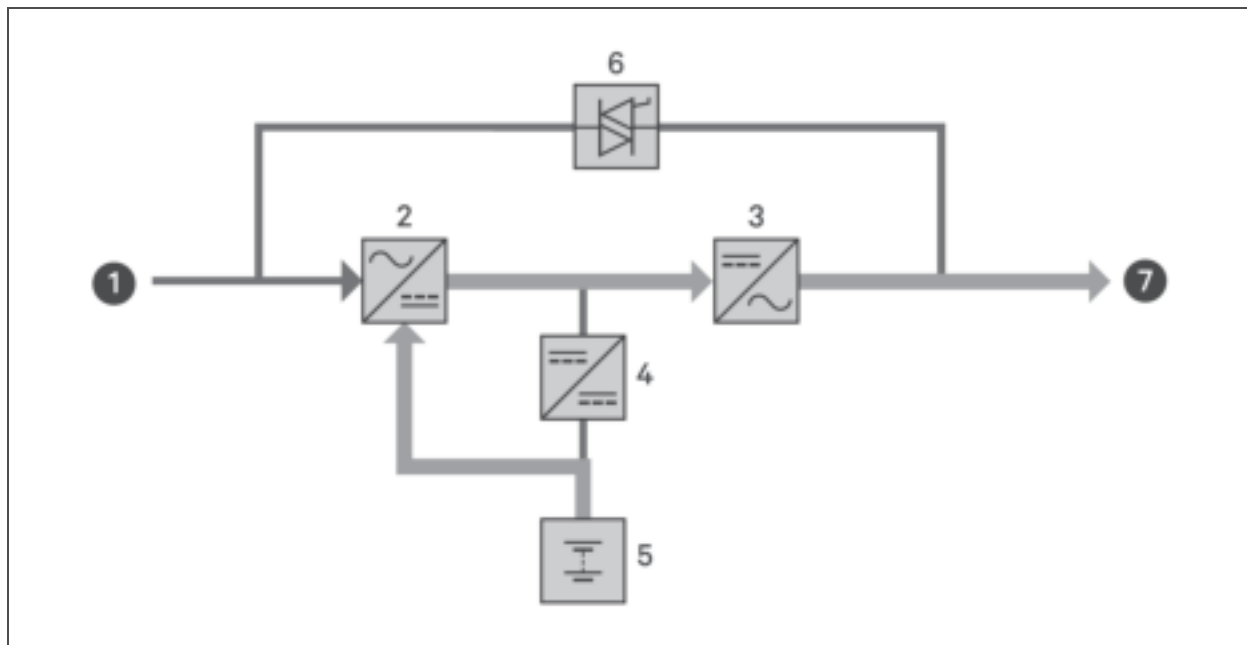

ITEM	DESCRIPTION
1	Mains/Utility input (by-pass input)
2	Rectifier/PFC
3	Inverter
4	Battery charger
5	Battery
6	Bypass static switch
7	UPS output

1.7.4 ECO Mode

NOTE: ECO mode is only available on a single-UPS system.

The energy-saving ECO mode reduces power consumption by powering the load via bypass if the bypass voltage is normal or by powering the load via the inverter when the bypass voltage is abnormal. You can use ECO mode to power equipment that is not sensitive to power-grid quality to via bypass and reduce power consumption.

NOTE: During Eco mode, if a bypass-failure or abnormal-bypass-voltage notification appears when the output is not overloaded, the UPS will transfer to Normal Mode. However, if a notification showing bypass failure or abnormal bypass voltage appears when the output is overloaded, the UPS will shut down the bypass.

1.7.5 Maintenance Bypass Mode

NOTE: 5-kVA to 10-kVA models include an MCB to switch the load to bypass. On 16-kVA to 20-kVA models, a dry contact may be used to trigger maintenance bypass.

Used when the UPS requires maintenance or repair, Maintenance-bypass mode powers the connected equipment with utility power while electrically isolating the internal UPS components.

NOTICE

Risk of power interruption. Can damage the connected equipment.

If utility power fails or if its quality is out of range while the UPS is in Maintenance Bypass Mode, the UPS may shut down without notice and shut-off output power to the load.

NOTE: The UPS has no user-serviceable parts. If the UPS malfunctions and requires service, visit <http://www.VertivCo.com/en-us/support/> or contact your local Vertiv representative.

Figure 1.16 Maintenance-bypass Operation

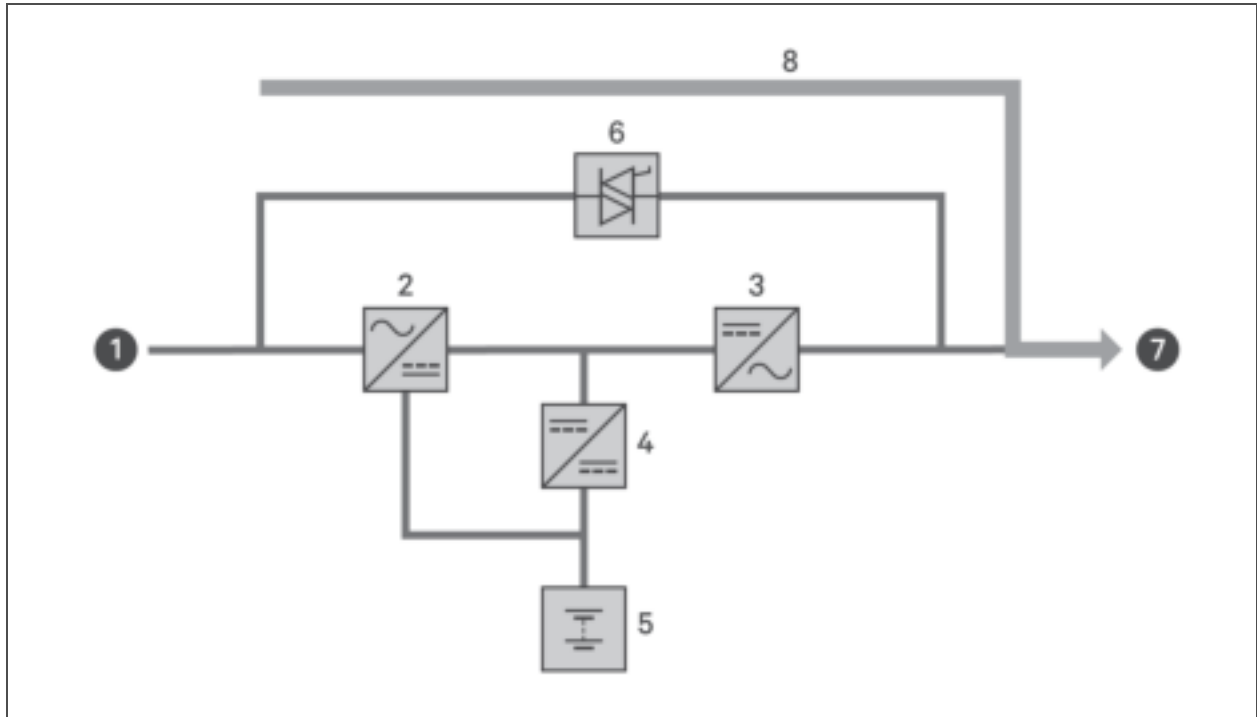

ITEM	DESCRIPTION
1	Mains/Utility input (by-pass input)
2	Rectifier/PFC
3	Inverter
4	Battery charger
5	Battery
6	Bypass static switch
7	UPS output
8	Maintenance by-pass

This page intentionally left blank

2 INSTALLATION

Do not start the UPS until after the installation is finished, the system is commissioned by an authorized engineer, and the external-input circuit breakers are closed.



WARNING! Risk of electrical shock. Can cause equipment damage, injury and death. Before beginning installation, verify that all external overcurrent protection devices are open (Off), and that they are locked-out and tagged appropriately to prevent activation during the installation, verify with a voltmeter that power is Off and wear appropriate, OSHA-approved personal protective equipment (PPE) per NFPA 70E. Failure to comply can cause serious injury or death. Before proceeding with installation, read all instructions. Follow all local codes.

2.1 Unpacking and Inspection

Unpack the UPS and conduct the following checks:

- Inspect the UPS for shipping damage. If any shipping damage is found, report it to the carrier and your local Vertiv representative immediately.
- Check the accessories included against the packing list. If there is any discrepancy, contact your local Vertiv representative immediately.



CAUTION: The UPS is heavy (see [Specifications](#) on page 61, for the weight). Take proper precautions when lifting or moving the unit.

2.2 Pre-installation Preparation

- Install the UPS indoors in a controlled environment, where it cannot be accidentally turned Off. The installation environment should meet the specifications listed in [Specifications](#) on page 61.
- Place the UPS in an area of unrestricted air-flow around the unit, away from water, flammable liquids, gases, corrosives, and conductive contaminants. Avoid direct sunlight

NOTE: Operating the UPS in temperatures above 77°F (25°C) reduces battery life.

2.2.1 Installation Clearances

Maintain at least 4 in. (100 mm) clearance in the front and rear of the UPS. Do not obstruct the air inlets on the front panel and rear panel of the UPS. Blocking the air inlets reduces ventilation and heat dissipation, shortening the service life of the unit.

2.3 Installing the UPS

The UPS may be installed as a tower or in a rack, depending on available space and use considerations. Determine the type of installation and follow the appropriate instructions. See [Tower Installation](#) below or [Rack Installation](#) below.

NOTE: For 16-kVA and 20-kVA models, the unit orientation is the same. See **1.2** on page 4, for the installed position.

NOTE: When installing the UPS or making input and output connections, comply with all relevant safety codes and standards

2.3.1 Tower Installation

To install the UPS as a tower:

1. Take the support bases out of the accessories box.

Figure 2.1 Support bases

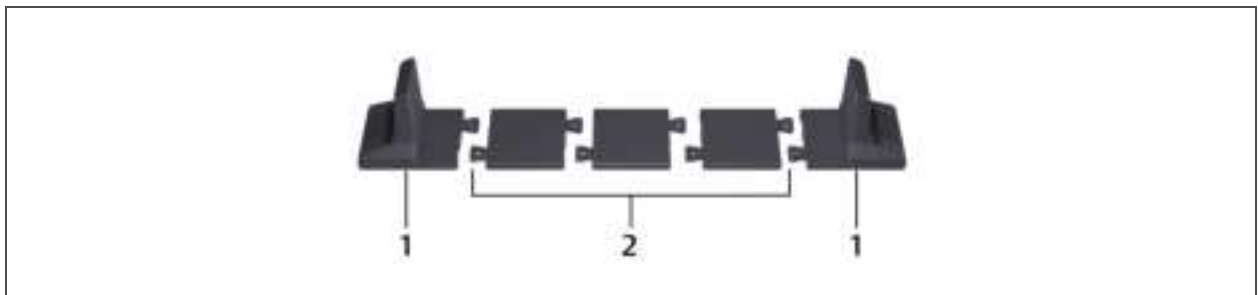

NO.	DESCRIPTION
1	Support bases
2	Spacers with connectors

2. If optional, Liebert® external battery cabinets will be connected, take out the spacers shipped with the battery cabinet.
3. Connect the spacers and the support bases as shown in **Figure 2.1** above. Each GXT5 requires 2 support bases, one in the front and one in the rear.
4. Place the GXT5 and any battery cabinets on the 2 support bases.

2.3.2 Rack Installation

When installed in a rack enclosure, the GXT5 UPS and external battery cabinets (EBC) must be supported by a shelf or rack-mount rails. Because different rack-mount options install differently, refer to the installation instructions provided with the rack-mount kit.



CAUTION: The GXT5 is heavy. The UPS must be installed as near the bottom of a rack as possible. If placed too high, it can make the rack top-heavy and prone to tipping over. For unit weights, see [Specifications](#) on page 61.

2.4 Installing External Battery Cabinets

Optional, external battery cabinets (EBC) may be connected to the UPS to provide additional battery run time. For approximate battery run times with additional EBCs, see [Battery Run Times](#) on page 69.

External battery cabinets are placed on one side of the UPS in a tower configuration or stacked beneath the UPS in a rack configuration. Up to 6 EBCs may be connected to the UPS.



WARNING! Risk of electric shock. Can cause injury or death. Disconnect all local and remote electric power supplies before working with the UPS. Ensure that the unit is shut down and power has been disconnected before beginning any maintenance.



CAUTION: The external battery cabinet(s) are heavy (see [Specifications](#) on page 61. Take proper precautions when lifting them.

To install the EBC(s):

1. Inspect the EBC for freight damage. Report damage to the carrier and your local dealer or Vertiv representative.
2. For tower installation:
 - An additional set of support-base extensions ships with each EBC.
 - See the steps in [Tower Installation](#) on the previous page, to connect the support extenders and install the bases.

– or –

For rack installation:

- Rack-mount hardware ships with the EBC.
- Refer to the instructions included with the rack-mount kit to install.

NOTE: Optional slide rails and securing hardware are sold separately. Please contact your Vertiv representative for options and Vertiv Technical Support for assistance.

3. Verify that the EBC breaker is in the "Off" position.
4. Connect the supplied EBC cables to the rear of the cabinet, then to the rear of the UPS, see [Figure 22](#) on the next page.
5. Turn the EBC breaker to the "On" position.
6. Verify the circuit breaker on the EBC is in the "On" position.
The additional back-up run time is enabled.

NOTE: When removing an EBC, turn off the circuit breaker on the rear of the cabinet before disconnecting the cable.

NOTE: If shipping or storing the UPS for an extended time, disconnect the EBC(s) minimize stand-by current drain on the batteries and help maintain design life.

Figure 2.2 EBCs connected to the UPS

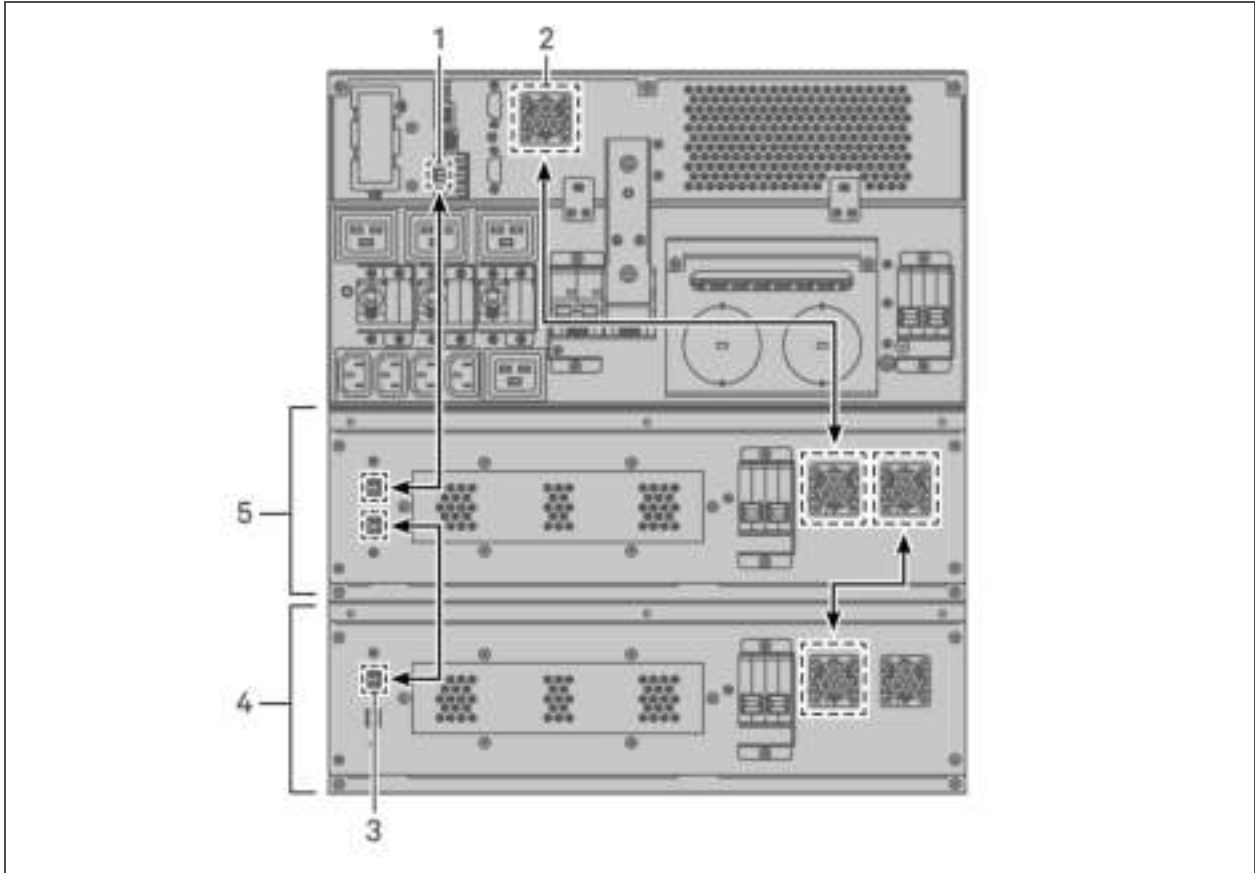

ITEM	DESCRIPTION
1	EBC-detection dry-contact port (See Table 2.4 on page 33, for details.)
2	EBC connector
3	EBC-detection port
4	External battery cabinet
5	External battery cabinet

2.5 Installing a Power-distribution Box

The 5-kVA to 10-kVA models ship with a removable power-distribution box (POD) installed, see [Terminal-block Connections](#) on page 27, to make the electrical connections to the UPS. For removal, see the appropriate procedures in [Maintenance](#) on page 53.

For 16-kVA to 20-kVA models, the POD ships separately and must be attached to the rear of the UPS. See [Removable Power-distribution Boxes](#) on page 10, for the POD options compatible with your GXT5 model.

NOTE: Do not operate the UPS with the POD removed. To shut off all power to the POD and to the load, utility input power must be disconnected.

To attach the POD on 16-kVA to 20-kVA units:

1. On the rear of the unit, unscrew the two fixing screws from the POD-location cover, see **Figure 2.3** below, and remove the cover.
2. Insert the POD receptacles into the ports, and connect the PP75 terminal.
3. Align the POD with the installation hole, then insert and secure the POD.

Figure 2.3 POD-location cover on 16-kVA to 20-kVA models

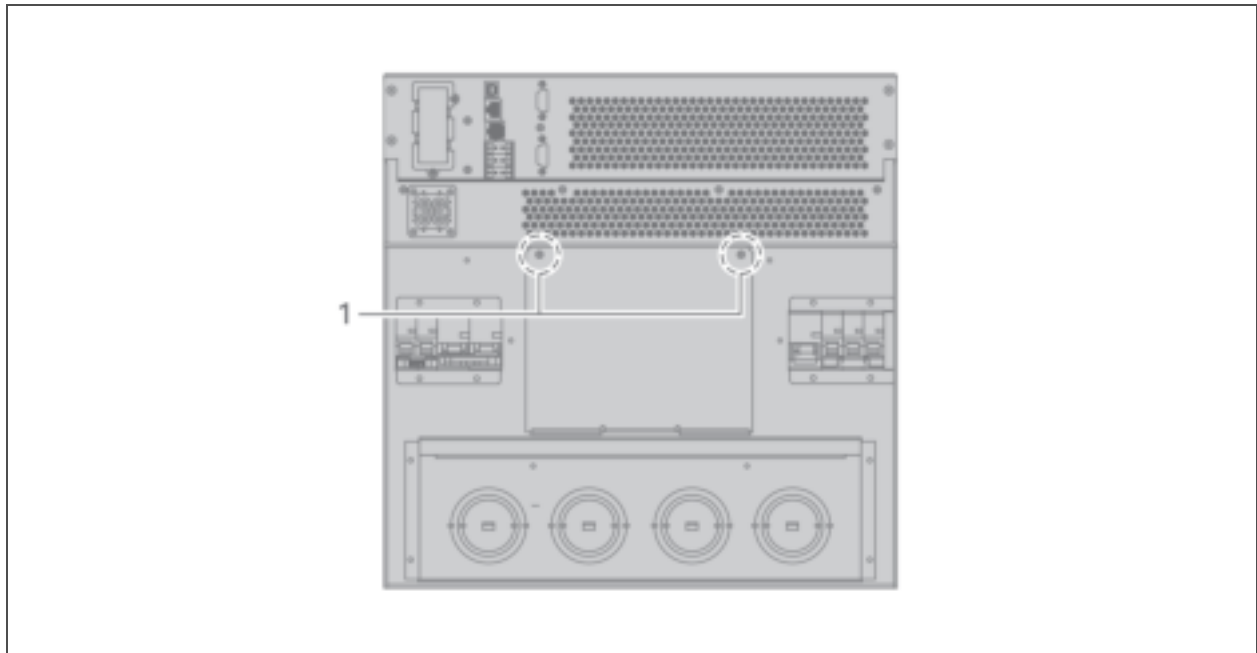

ITEM	DESCRIPTION
1	Fixing screws

2.6 Hardwired Input/Output Connections



WARNING! Risk of electrical shock. Can cause equipment damage, injury and death. Before beginning installation, verify that all external overcurrent protection devices are open (Off), and that they are locked-out and tagged appropriately to prevent activation during the installation, verify with a voltmeter that power is Off and wear appropriate, OSHA-approved personal protective equipment (PPE) per NFPA 70E. Failure to comply can cause serious injury or death. Before proceeding with installation, read all instructions. Follow all local codes.

Table 2.1 on the next page, lists the four types of I/O connection are available depending on the UPS model. Some models offer more than one type.

Table 2.1 I/O Connection Types by Model

MODEL	LINES IN/OUT	CONFIGURATION
5-kVA, 6-kVA	1-in 1-out	Common source
8-kVA, 10-kVA	1-in 1-out	Common Source or Split bypass
16-kVA, 20-kVA	1-in 1-out or 3-in 1-out	Common Source or Split bypass

2.6.1 Branch Circuit Breaker

The installer must provide an upstream branch circuit breaker, see **Table 2.2** below, for the ratings. The input circuit breaker on the distribution box and the output circuit breaker on the rear of the power distribution box disconnect all power between the main cabinet and the distribution box. **Figure 2.4** on the facing page, shows a diagram of the circuit breakers.

Observe the following guidelines and specifications when making the hard-wire input and output connections:

- Provide circuit-breaker protection according to local codes. The mains disconnect should be within sight of the UPS or have an appropriate lock-out.
- Maintain service space around the UPS or use flexible conduit.
- Provide output-distributions panels, circuit-breaker protection, or emergency disconnects according to local codes.
- Do not install input and output wiring in the same conduit.

Models equipped with a manual bypass breaker pass bypass power directly to the bypass breaker from the input terminal block. The input circuit breaker on the distribution box does not disconnect power from the manual bypass breaker.

Table 2.2 Branch circuit breaker ratings

UNIT RATING	MAXIMUM BREAKER RATING
5 kVA	60 A
6 kVA	
8 kVA	70 A
10 kVA	
16 kVA	1-phase: 160 A 3-phase: 50 A
20 kVA	

Figure 2.4 Circuit-breakers diagram

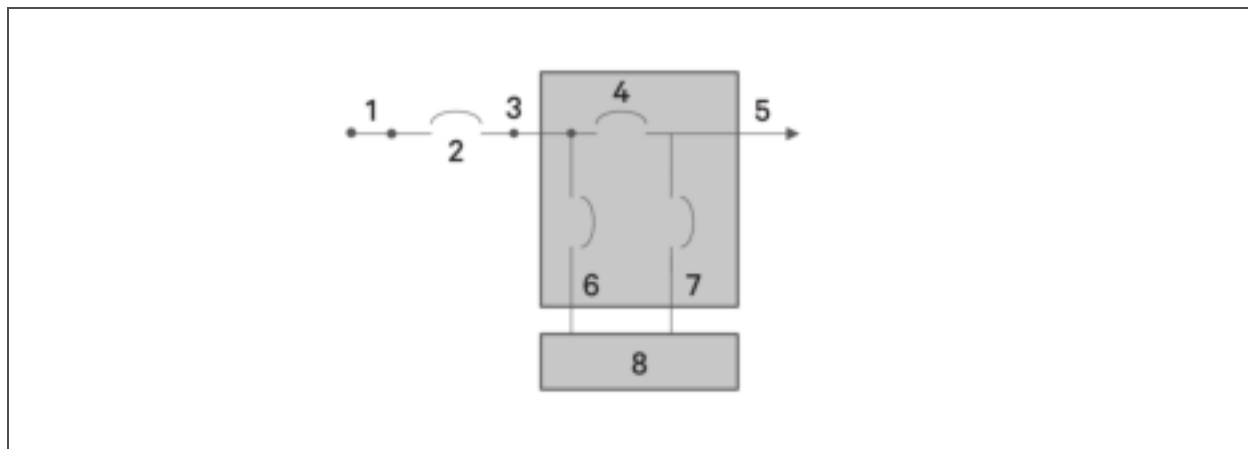

ITEM	DESCRIPTION
1	Mains/Utility
2	External branch CB
3	Input
4	MB CB
5	Output
6	Input CB
7	Output CB
8	UPS-PFC, battery inverter

2.6.2 Terminal-block Connections

On 5-kVA to 10-kVA models, the hard-wire connections to the terminal blocks are made through knockouts on the POD attached to the rear of the unit. On 16-kVA to 20-kVA models, the knockouts are on the rear of the unit. See [Removable Power-distribution Boxes](#) on page 10, for the location of the input/output knockouts on your GXT5 model.

Table 2.3 on the next page, details the electrical-connection specifications.

Table 2.3 Terminal-block electrical specifications

UPS MODEL	RECOMMENDED (MAXIMUM) EXTERNAL OVERCURRENT PROTECTION	RECOMMENDED WIRE SIZE (INCLUDING GROUND WIRE) (75°C COPPER WIRE)	MAXIMUM WIRE SIZE ACCEPTED BY TERMINAL BLOCK	TERMINAL TIGHTENING TORQUE
GXT5-5000IRT5UXLN	60 A	10 mm ² (7 AWG)	16 mm ² (6 AWG)	20 in.-lb (2.26 Nm)
GXT5-5000IRT5UXLE				
GXT5-5000HVRT5UXLN				
GXT5-6000IRT5UXLN				
GXT5-6000IRT5UXLE				
GXT5-8000IRT5UXLN	70 A	10 mm ² (7 AWG)	16 mm ² (6 AWG)	20 in.-lb (2.26 Nm)
GXT5-8000IRT5UXLE				
GXT5-8000HVRT5UXLN				
GXT5-10KIRT5UXLN				
GXT5-10KIRT5UXLE				
GXT5-10KHVRT5UXLN	1-phase: 160 A 3-phase: 50 A	35 mm ² (1 AWG)	53.5 mm ² (1/0 AWG)	110 in.-lb (12.4 Nm)
GXT5-16KIRT9UXLN				
GXT5-16KIRT9UXLE				
GXT5-20KIRT9UXLN				
GXT5-20KIRT9UXLE				

To make the terminal-block connections:

1. Loosen the screws from the cable-entry/conduit-box cover, and pull the cables through the cable-entry hole/knockout leaving some slack for connection.

NOTE: Some UPS models have both a cable-entry hole and knockouts. For EU users, we recommend that you use the cable-entry hole. However, if you use the knockouts, you must use a suitable cable and gland or risk electric shock. For North American users, we recommend using the knockouts, and you must install input and output wiring in separate conduit.

2. Referring to the appropriate terminal-block connection instructions, connect the cables to the corresponding input/output terminals and use a torque wrench to turn the screw clockwise until tightened as specified in **Table 2.3** above.
 - [Connecting to Terminal Blocks on 5-kVA and 6-kVA models](#) on the facing page
 - [Connecting to Terminal Blocks on 8-kVA and 10-kVA models](#) on the facing page
 - [Connecting to Terminal Blocks on 16-kVA and 20-kVA models](#) on page 30
3. Re-install the cable-entry/conduit-box cover, and tighten the screws.

2.6.3 Connecting to Terminal Blocks on 5-kVA and 6-kVA models

These models offer a single type of I/O connection, 1-in 1-out common source. **Figure 2.5** below, shows the terminal block. Refer to the details in [Terminal-block Connections](#) on page 27, when making the connections.

Figure 2.5 Terminal Block, 5-kVA and 6-kVA models

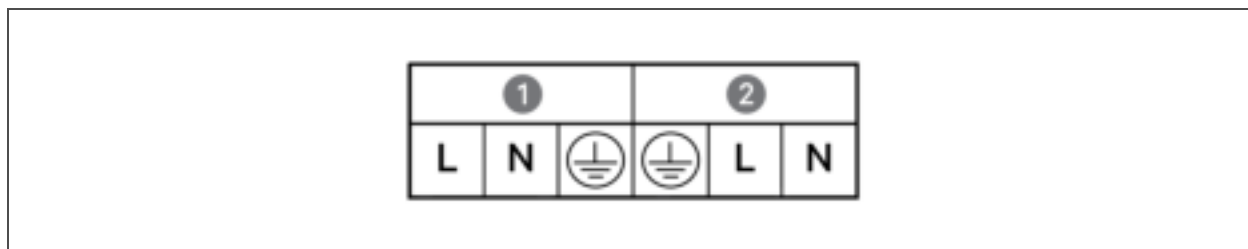

ITEM	DESCRIPTION
1	Output
2	Input

2.6.4 Connecting to Terminal Blocks on 8-kVA and 10-kVA models

These models offers two types of I/O connection. A single shorting cable ships installed on the on the terminal block. Refer to the details in [Terminal-block Connections](#) on page 27, when making the connections. **Figure 2.6** below, shows the shorting cable installed for a split-bypass connection

Figure 2.6 1-in 1-out Split-bypass Connection, 8-kVA and 10-kVA models

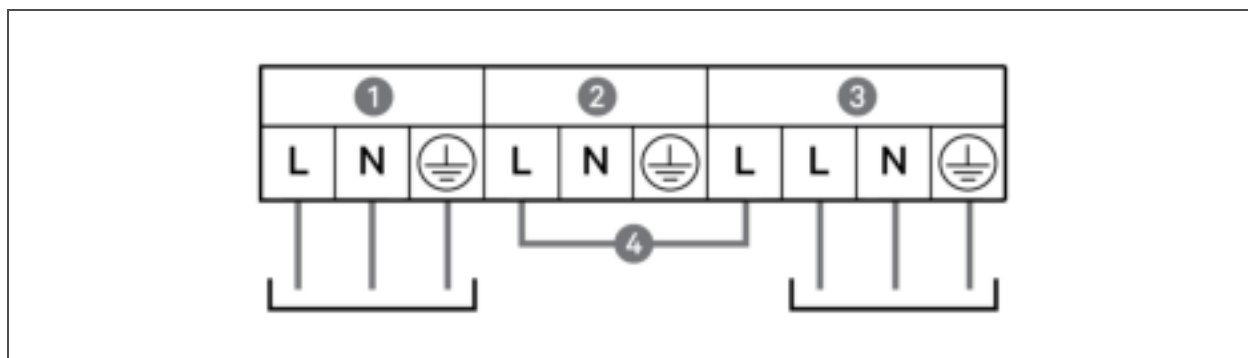

ITEM	DESCRIPTION
1	Output
2	Bypass
3	Input
4	Shorting cable (installed at factory)

2.6.5 Connecting to Terminal Blocks on 16-kVA and 20-kVA models

These models offers four types of I/O connection. One shorting cable (W01) ships installed on the terminal block. Two additional shorting cables are included with the accessories to wire the different types. Refer to the details in [Terminal-block Connections](#) on page 27, when making the connections.

- Figure 2.7 below, shows the 3-in 1-out common-source connection
- Figure 2.7 below, shows the 1-in 1-out split-bypass connection.
- Figure 2.7 below, shows the 1-in 1-out common-source connection

Figure 2.7 3-in 1-out Common-source Connection, 16-kVA and 20-kVA models

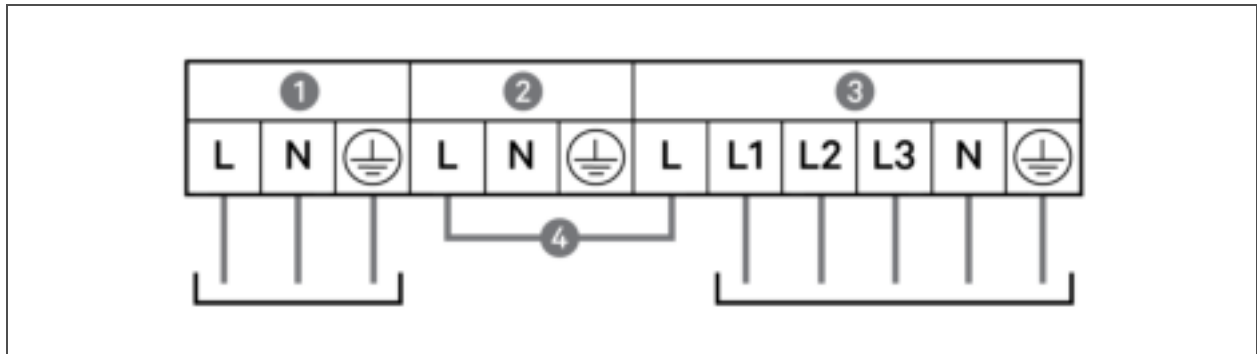

ITEM	DESCRIPTION
1	Output
2	Bypass
3	Input
4	Shorting cable (W01), installed at factory

Figure 2.8 1-in 1-out Split-bypass Connection, 16-kVA and 20-kVA models

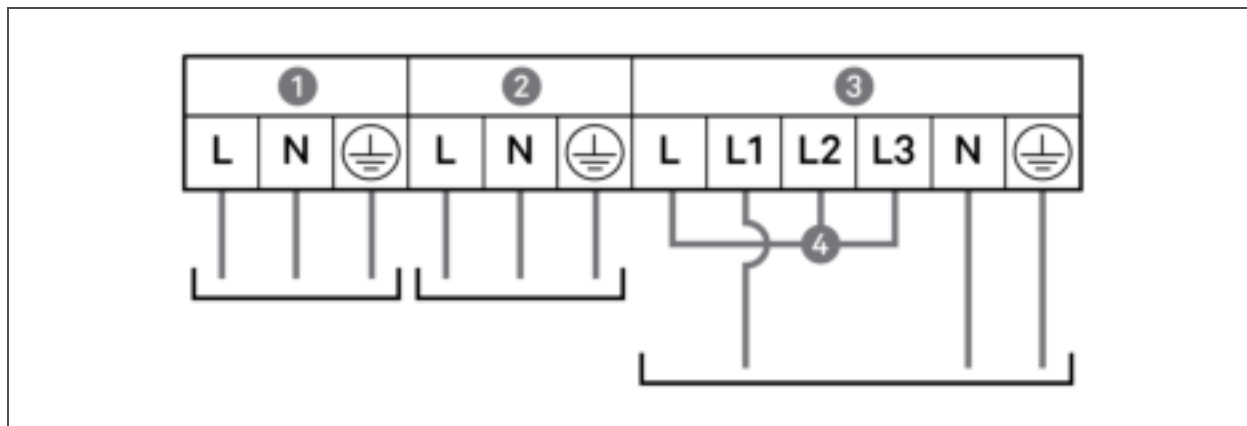

ITEM	DESCRIPTION
1	Output
2	Bypass
3	Input
4	Shorting cable (W02), included with accessories.

Figure 2.9 1-in 1-out Common-source Connection, 16-kVA and 20-kVA models

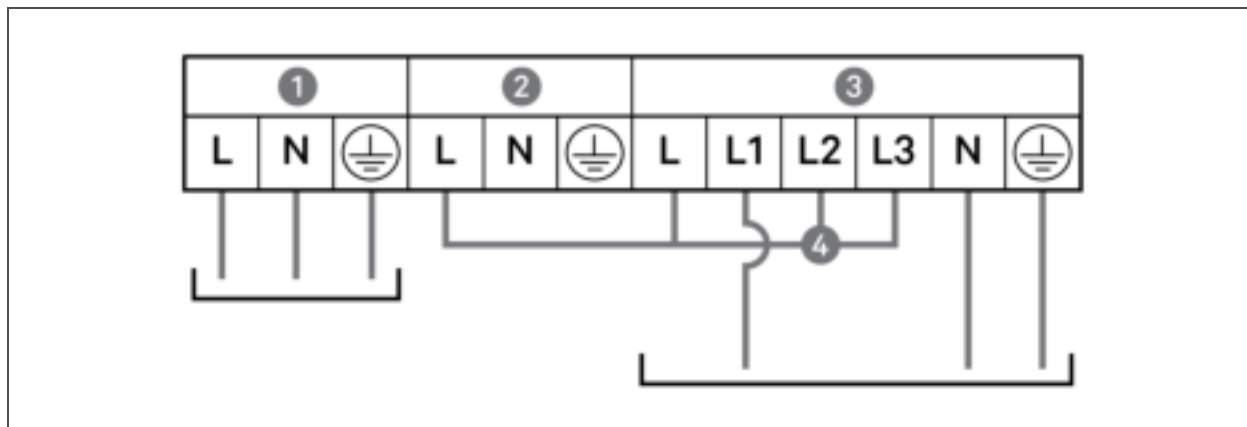

ITEM	DESCRIPTION
1	Output
2	Bypass
3	Input
4	Shorting cable (W03), included with accessories

2.7 Communication Connections

The UPS offers several communication interfaces and ports.

NOTE: We recommend that signal-cable lengths be less than 10 ft (3 m), and are kept away from power cabling.

2.7.1 Connecting IntelliSlot Communication

The IntelliSlot ports accepts two optional cards:

The Liebert® IntelliSlot™ Relay card (IS-RELAY) card provides dry-contact relay output for custom-wired applications and delivers support for Trellis® Power Insight™ software.

The Liebert® IntelliSlot™ Unity card (RDU101) provides SNMP and/or RS-485 monitoring of the UPS across the network and/or building management system and lets you monitor external temperature, humidity and contact-closure inputs using external sensors.

See the appropriate figure for your model in [Rear Panels](#) on page 4, for the location of the card port.

To install an IntelliSlot Card:

1. Remove the screws from the slot cover plate and remove the plate.
2. Insert the card into the slot, and secure with the screws that held the cover plate.

To make connections to the card, refer to the *Liebert® IntelliSlot™ Installer/User Guide* for the appropriate card available at www.VertivCo.com.

2.7.2 Connecting to the Dry-contact Port

The UPS includes a dry-contact port. See the appropriate figure for your model in [Rear Panels](#) on page 4, for the location of the port. **Figure 2.10** below, shows the ports and **Table 2.4** on the facing page, describes each port.

The I/O dry contact port capacity is 125 Vdc, 0.5 A; 30 Vdc, 1 A

Figure 2.10 Dry-contact Port and Pin Layout

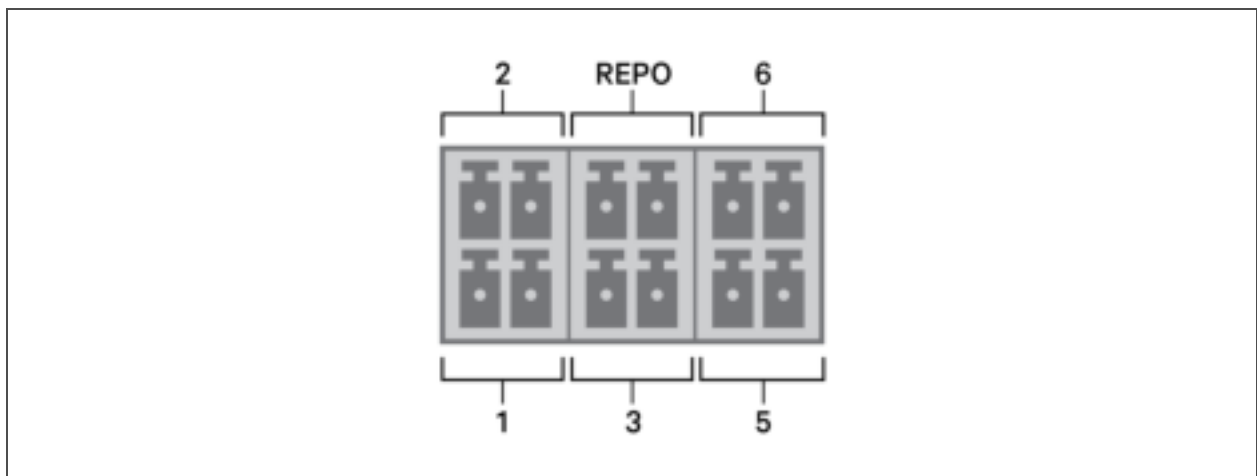

NOTE: Pins 7 and 8 are shorted before delivery.

NOTE: The emergency power-off (EPO) action of the UPS closes the rectifier, inverter and static bypass, but it cannot disconnect the UPS mains input inside. To completely disconnect the UPS, disconnect the upstream input circuit breaker when generating the EPO. For details on REPO connection and operation, see [Connecting a Remote Emergency Power-off \(REPO\) Switch](#) below.

Table 2.4 Dry-contact Connection and Pin-out Descriptions

PORT NO.	PORT NAME	PIN NO.	PIN NAME	DESCRIPTION
1	Input 1	1	Disable/Battery mode shutdown/Any mode shutdown (Remote Comms Shutdown)	Default: Disable, can be set via the LCD settings page. User can choose dry contact as NO/NC. when NO, Pin 1 and Pin 2 are shorted, the function is active. when NC, Pin 1 and Pin 2 are open, the function is active.
		2	Signal Ground	Signal Ground
2	Input 2	3	Disable/Battery mode shutdown/Any mode shutdown (Remote Comms Shutdown)	Default: Disable, can be set via the LCD settings page. User can choose dry contact as NO/NC. when NO, Pin 1 and Pin 2 are shorted, the function is active. when NC, Pin 1 and Pin 2 are open, the function is active.
		4	Signal Ground	Signal Ground
3	555 Battery Detection	5	EBC Detection (DSCHG)	Default: No EBC User can know the quantity of EBC, when NO, Pin 5 and Pin 6 link to the defective port of EBC .
		6	EBC Detection (THR)	Default: No EBC User can know the quantity of EBC, when NO, Pin 5 and Pin 6 link to the defective port of EBC .
REPO	REPO Input	7	+5V	REPO power supply, 5-Vdc 100-mA
		8	REPO Coil-NC	NC, activated when Pin 7 and Pin 8 is open NOTE: For details on REPO connection and operation, see Connecting a Remote Emergency Power-off (REPO) Switch below.
5	Output 5	9	Low Battery/On battery/On bypass/UPS fault	Default: Low battery, can be set via the LCD settings page. When the system has a fault, short Pin 9 and Pin 10
		10	Signal Ground	Signal Ground
6	Output 6	11	Low Battery/On battery/On bypass/UPS fault	Default: UPS fault, can be set via the LCD settings page. When the system has a fault, short Pin 11 and Pin 12
		12	Signal Ground	Signal Ground

2.7.3 Connecting a Remote Emergency Power-off (REPO) Switch

The UPS includes an EPO connection in the dry-contact port. See the appropriate figure for your model in [Rear Panels](#) on page 4, for the location of the port.

UPS ships with a REPO jumper installed, allowing the UPS to operate as a normally-closed switch system (fail-safe). Opening the circuit disables the UPS. To connect a REPO switch that opens the circuit to shut down the rectifier and inverter and power-off the UPS, use a cable from the remote switch to plug into the REPO-port on the UPS.

In normal conditions, the REPO switch cannot cut off the UPS input power. When the REPO switch trips, the UPS generates an alarm and immediately cuts-off output power. When the emergency condition is resolved, the UPS will not return to normal operation until you reset the REPO switch and manually power-on the UPS.

To make the cable for the REPO connection:

Figure 2.11 below, shows the cable required to make the connection. We recommend using 18 AWG to 33 AWG (0.82 mm² to 0.33 mm²) copper-core cable.

1. Remove the insulation from the end of two cables.
2. Insert the stripped end into the plug terminals 1 and 2 respectively, then press down the terminals. Make sure that the cables are secure in the plug to prevent failure because of loose contact.

To connect a UPS to the REPO switch



CAUTION: To maintain safety (SELV) barriers and electromagnetic compatibility, signal cables should be shielded and run separately from power cables.

1. Connect one end of the cable to the remote switch, see **Figure 2.11** below.
2. Remove the factory-installed jumper from pins 7 and 8 of the dry-contact port on the UPS
3. Connect the plug to pins 7 and 8.

Figure 2.11 Cable/Plug for Connecting REPO switch to UPS REPO port

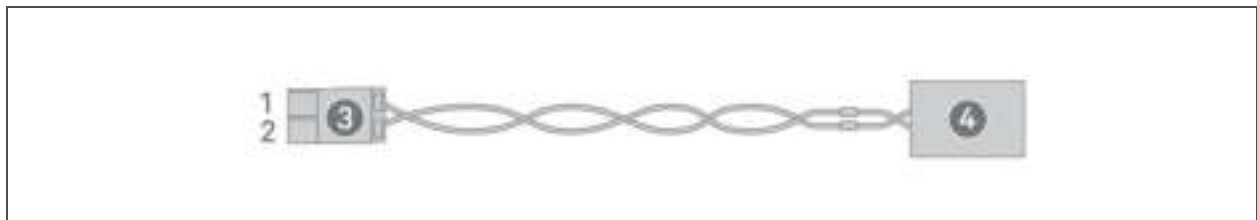

ITEM	DESCRIPTION
1	Terminal 1
2	Terminal 2
3	Plug (connects to REPO port on UPS)
4	REPO switch

2.7.4 Connecting a USB Cable

The UPS includes a USB connector. See the appropriate figure for your model in [Rear Panels](#) on page 4, for the location of the port.

The standard, B-type USB port connects the UPS to a network server or other computer system.

The USB port supports HID/CDC protocol. The CDC protocol is reserved for service software. To use the HID protocol for monitoring, get the HID protocol from www.VertivCo.com.

2.7.5 Connecting CLI Communication Cables

The UPS supports the Vertiv command-line interface for operation with ACS and other third-party monitoring protocols. The RJ-45 port is used for CLI connection. See the appropriate figure for your model in [Rear Panels](#) on page 4, for the location of the port. The pin-out, described in **Table 2.5** below, is consistent with the ACS pin-out.

Table 2.5 RJ-45 Port Pin-out

PIN	SIGNAL	DIRECTION
1	NC	—
2	NC	—
3	TXD	O
4	GND	—
5	NC	—
6	RXD	I
7	NC	—
8	NC	—

2.7.6 Connecting Sensors to the Control Port

The UPS supports the Vertiv temperature and temperature/humidity sensors. The RJ-45 port is used for sensor connection. See the appropriate figure for your model in [Rear Panels](#) on page 4, for the location of the port.

When connected, the sensor address must be 1 to 20.

The GXT5 supports two sensors:

- Liebert® IRM-S01T
- Liebert® IRM-S02TH

2.8 Installing a Parallel System

10-kVA, 16-kVA, and 20-kVA models may be configured in a parallel system. The UPS parallel system provides $N + X$ ($1 \leq N + X \leq 3$, $X=0$ or 1) parallel configuration. N stands for the basic parallel sets, X stands for the redundant sets.

All electrical requirements, including external-distribution panel and branch circuit breaker, apply to each UPS in a parallel system, which are then connected in ring configuration for redundancy and additional reliability. System load information can be accessed via any controller/display in the system.

The following are requirements for the parallel-connected system:

- Each UPS must have the same capacity and must be connected to the same mains/utility source.
- If a residual-current detector (RCD) is required, it must be correctly-set and installed before the same neutral-line input terminal. See safety and regulatory information, available at <https://www.vertivco.com/ComplianceRegulatoryInfo>.
- The output of each ups must be connected to the same output bus.

- The parameter configuration for each UPS must be identical.
- Because the parallel system is not fitted with auxiliary-contact detection devices for the output circuit breaker or the maintenance-bypass circuit breaker of each UPS, You must strictly-follow the procedures for transferring between operating modes when removing a single UPS from the parallel system before maintenance and when adding a single UPS after maintenance. Failure to observe the procedure may affect the reliability of the load power supply.

Figure 2.12 below, shows an example of the 10-kVA model connected as a 2 + 1 parallel system connected in a ring configuration.

NOTE: 8-kVA models do not support parallelling at this time.

NOTE: You must use Vertiv parallel cables for the connection.

NOTE: If a fault occurs during parallel-system operation, shut-off the system and make sure the cables are connected correctly, see **Figure 2.12 below.**

! CAUTION: Risk of improper disconnection. Can equipment damage. Do not disconnect parallel-system cables while the system is operating.

Figure 2.12 Connection of 2 + 1 Parallel System

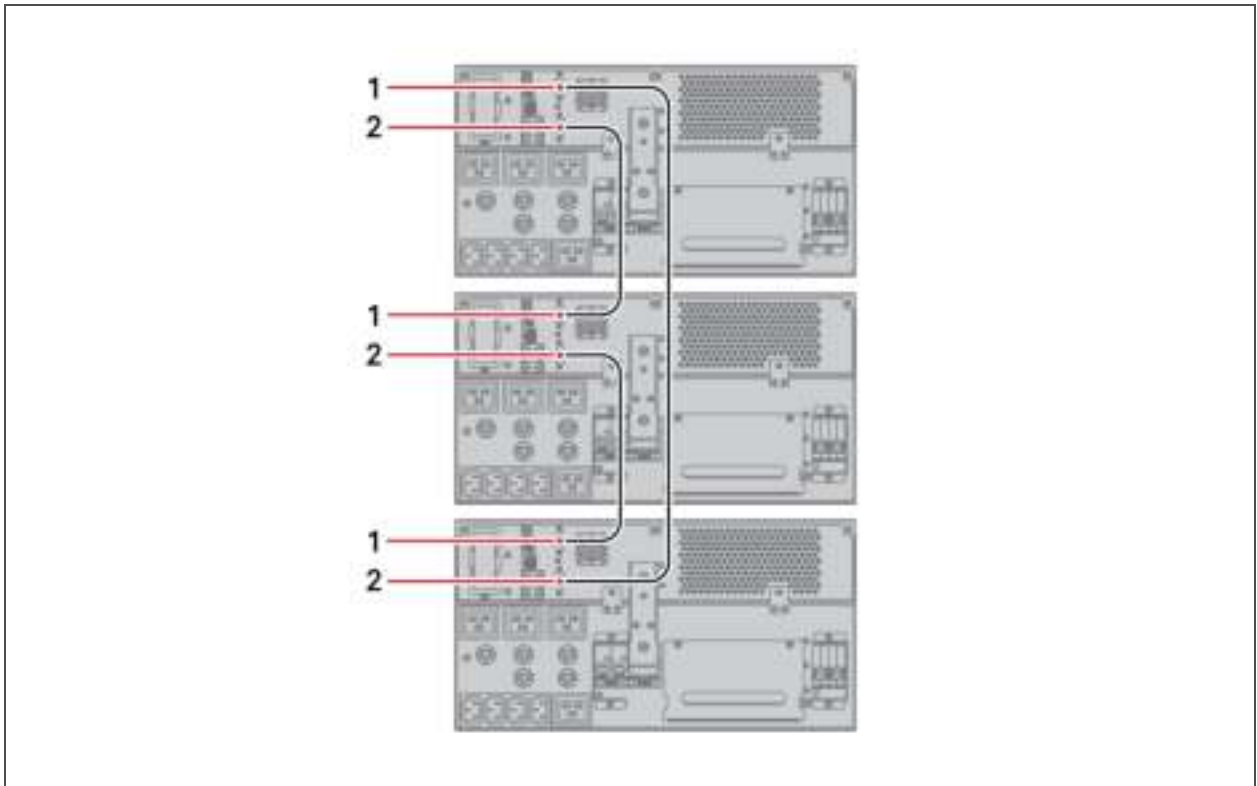

ITEM	DESCRIPTION
1	Upper connector
2	Lower connector

2.8.1 First-time Start-up of Parallel System

IMPORTANT! Do not start the UPS until after the installation is finished, the system is commissioned by an authorized engineer, and the external input circuit breakers are closed.



CAUTION: Starting the UPS applies mains/utility power to the output terminals. Make sure that the load power is safe and ready to accept power. If the load is not ready, isolate the load with the output terminal.

The "Parallel" parameters for each UPS in the system must be set and synchronized at first start-up.

To start and set parameters for the parallel system:

1. Make sure that the output MCBs of all units in the parallel system are open, then close the input MCB on each UPS.
Each UPS powers on, a self-check screen displays, and the alarm/run indicators are lit for about 5 seconds.
2. Wait about 30 seconds to allow the rectifier start-up to finish, then at each UPS, set the parallel parameters as follows:

NOTE: If the "Parallel Comm Fail" Alarm displays, clear it and proceed. Communication should not fail after the parallel settings are synchronized.

- a. On the display, press **Enter** to display the Main Menu, then use the arrow buttons to select *Settings*, and press **Enter**.

NOTE: To adjust the settings, you must enter a password. See [Editing Display and Operation Settings](#) on page 51, for details on entering the password and editing the setting parameters.

- b. Use the arrow buttons to select the *Parallel* tab, then press **Enter** to display the parameters list.
- c. Select and Enter each parameter setting, and then use last item in the list, Sync parallel parameters, to validate the settings.
For a full description of UPS display functions and settings, see [Operation and Display Panel](#) on page 41.
3. After confirming the parallel parameters and each UPS is operating normally, commission the parallel system, see [Commissioning Parallel System](#) below.

2.8.2 Commissioning Parallel System



CAUTION: When powering-on the parallel system, confirm that the external output MCB for each UPS is closed and that all of the inverter output is connected in parallel.



CAUTION: To avoid load power failure, confirm that the system is working normally, then feed power to the load.

To commission the parallel system:

1. Close the external output MCB and input MCB on each UPS, then wait about 30 seconds to allow the rectifier start-up to finish.
2. At the first UPS, press the power button for 2 seconds and note that the run indicator (green) is lit, then measure the inverter-output voltage and verify that it is normal.
3. Repeat step 2 for each UPS in the parallel system.

2.8.3 Adding a Single UPS to the Parallel System



CAUTION: When adding or replacing a UPS in the parallel system, make sure that all parallel-cabling is correct before powering on the additional/replacement unit.

NOTE: You may also use this procedure when replacing a faulty UPS in the system. The difference is noted in the procedure steps.

1. Connect the power cables and parallel-communication cables, and make sure that they are properly connected, without short-circuit.
2. Refer to [Commissioning Parallel System](#) on the previous page, to verify operation of the added unit then completely power-off the added UPS.
3. At any other UPS in the system, update the parallel parameters as follows:
 - a. On the display, press **Enter** to display the Main Menu, then use the arrow buttons to select *Settings*, and press **Enter**.
 - b. Use the arrow buttons to select the *Parallel* tab, then press **Enter** to display the parameters list.
 - c. Set the system count from N to N + 1, and then use last item in the list, Sync parallel parameters.

NOTE: If your are replacing a unit, do not update the system count, just sync the parallel parameters.

4. On the added UPS, close the external I/O switches, wait about 30 seconds to allow the rectifier start-up to finish, then power-on the inverter.
5. Make sure that there are no alarms and that the UPS and the parallel system are operating normally.

3 OPERATING THE UPS

3.1 Silencing the Audible Alarm

The audible alarm may sound during UPS operation. To silence the alarm, press and hold the **ESC** button for 2 seconds. The button is located on the front-panel display, see [Operation and Display Panel](#) on page 41.

3.2 Starting-up the UPS

IMPORTANT! Do not start the UPS until after the installation is finished, the system is commissioned by an authorized engineer, and the external input circuit breakers are closed.



CAUTION: Starting the UPS applies mains/utility power to the output terminals. Make sure that the load power is safe and ready to accept power. If the load is not ready, isolate the load with the output terminal.

The UPS starts in Normal Mode.

To start the UPS:

1. If included on your UPS model, make sure the maintenance-bypass switch is in the open “OFF” position and that the guard is secured in place.
2. Ensure that the REPO connector on the rear of the unit has a jumper between pins 7-8 or that it is properly wired to an Emergency Power- Off circuit (normally closed).
3. Make sure the breaker supplying power to the UPS is closed, and close the input breaker on the rear of the UPS.
4. If included on your UPS model, close the bypass breaker on the rear of the UPS
5. Close all output breakers on the rear of the UPS (or in an external panel board, if used).
6. If external battery cabinets are attached, close the breakers on the rear of each cabinet.
7. Power-on the UPS by pressing and holding the power button on the operation and display panel until the confirmation dialog appears. Use the Up/ Down arrows to select **YES**, then press **Enter**.
8. If this is the first-time start-up of the UPS, the Start-up Guidance wizard opens to set the basic parameters of the UPS. Follow the prompts.
For a full description of UPS display functions and settings, see [Operation and Display Panel](#) on page 41.

3.3 Transferring to Battery Mode

The UPS operates in Normal mode unless the mains/utility power fails or it is performing a battery self test, then it automatically transfers to Battery mode for the back-up time available or the mains/utility power is restored. Once input power is restored, the UPS returns to Normal mode.

NOTE: Battery back-up run times are listed in [Battery Run Times](#) on page 69.

3.4 Transferring from Normal to Bypass Mode

Press and hold the power button for 2 seconds.

- If the bypass power is within normal operating range, the option to continue to Bypass mode or turn-off the UPS displays:
 - a. Use the arrow buttons to select *To the Bypass* or *Turn off UPS*, and press **Enter**.
 - a. Use the arrow buttons to select *No* or *Yes*, then press **Enter** to confirm.
- If the bypass power is outside normal operating range, the option turn-off the UPS displays. Use the up/down arrows to select *No* or *Yes*, then press **Enter** to confirm.

3.5 Transferring from Bypass to Normal Mode

Press and hold the power button for 2 seconds.

- If the UPS is operating normally, without faults, the option to continue to turn-on or turn-off the UPS displays:
 - a. Use the arrow buttons to select *Turn on UPS* or *Turn off UPS*, and press **Enter**.
 - a. Use the arrow buttons to select *No* or *Yes*, then press **Enter** to confirm.

NOTE: The UPS automatically switches back to normal mode after an "overheated" or "overloaded" fault is cleared and normal power is restored.

3.6 Shutting-down the UPS Completely



WARNING! Risk of electric shock. Can cause injury or death. Disconnect all local and remote electric power supplies before working with the UPS. Ensure that the unit is shut down and power has been disconnected before beginning any maintenance.

For 5-kVA to 10-kVA models, transfer to Bypass mode, see [Transferring from Normal to Bypass Mode](#) above. Then, if power to the load is not needed, open the MCB.

For systems with direct power distribution, isolate the UPS from AC power by disconnecting the external-input MCB. If the main and bypass are independently powered, close the two input MCBs.

3.7 Remote Emergency Power-off (REPO)

REPO turns off the UPS in emergency conditions such as fire or flood. When an emergency occurs, the REPO switch turns off the rectifier and inverter and stops powering the load immediately. The battery stops charging and discharging.

To manually power-off in an emergency, disconnect the terminal connecting the REPO port on the rear of the UPS.

If mains/utility power is present, the UPS control circuit remains active even though output power is disabled. To remove all mains/utility power, disconnect the external main-input MCB.

4 OPERATION AND DISPLAY PANEL

The operation/display panel includes LED indicators, function keys, and an LCD interface to configure and control UPS operation.

Figure 4.1 UPS Front-panel Display

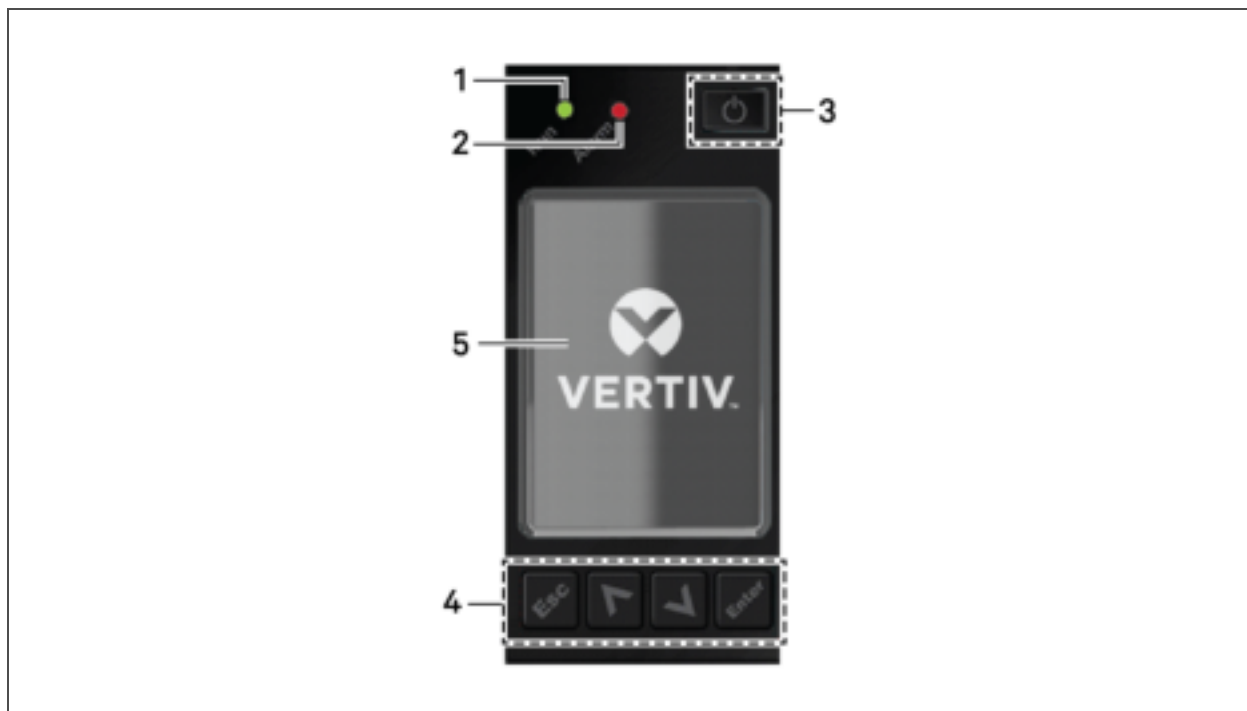



ITEM	DESCRIPTION
1	Run indicator LED, see LED Indicators on the next page.
2	Alarm indicator LED, see LED Indicators on the next page.
3	Power button, see Table 4.1 on the next page.
4	Menu keys, see Table 4.1 on the next page.
5	LCD panel.

Table 4.1 Display-panel Button Functions and Descriptions

BUTTON	FUNCTION	DESCRIPTION
	Enter	Confirm or enter selection.
	Up	Move to previous page, increase value, move left.
	Down	Move to next page, decrease value, move right.

Table 4.1 Display-panel Button Functions and Descriptions (continued)

BUTTON	FUNCTION	DESCRIPTION
	Escape	Go back.
	Power	Power-on the UPS, power-off the UPS, transfer to Bypass Mode.

NOTE: While the UPS is operating, the LCD will dim and display a screen saver if there is no active alarm or user interaction for two minutes, see **Figure 4.2** below. If an alarm or fault occurs or if any button is pressed, the UPS-flow screen displays.

Figure 4.2 LCD Screen Saver

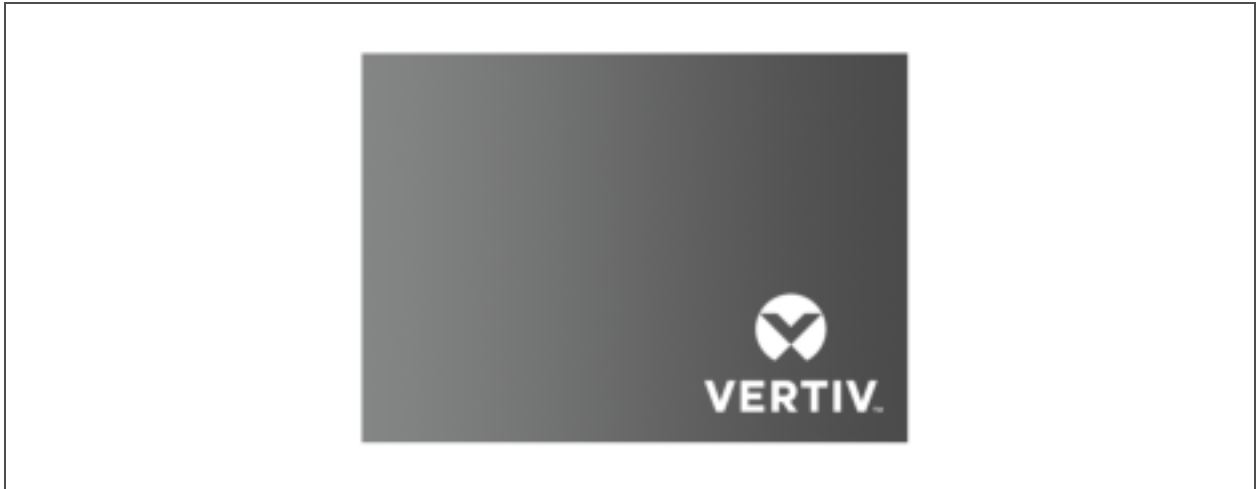

4.1 LED Indicators

The LEDs on the front-panel display indicate operation and alarm statuses of the UPS.

Table 4.2 LED Functions

INDICATOR	LED COLOR	LED STATE	INDICATES:
Run indicator	Green	On	UPS has output
		Blinking	Inverter is starting
		Off	UPS has no output
Alarm indicator	Yellow	On	Alarm occurs
	Red	On	Fault occurs
	N/A	Off	No alarm, no fault

NOTE: When an alarm is indicated, an alarm message is logged. **Table 4.4** on page 50, describes the alarm messages you may see. When a fault is indicated, front-panel display list the fault, which are described in **Table 6.2** on page 60.

4.2 LCD Menu and Screens

The menu-driven LCD user interface lets you browse the UPS status, view operating parameters, customize settings, control operation, and view alarm/event history. Use the function keys to navigate through the menu, and view statuses or select settings in the screens.

4.2.1 Start-up and Flow Screens

At start-up, the UPS executes a system test and displays the Vertiv logo screen for about 10 seconds, shown in **Figure 4.1** on page 41. After the test completes, an overview screen shows status information, the active (green) power path, and the non-working power path (gray), see **4.2.1** above.

Figure 4.3 UPS Flow Screen

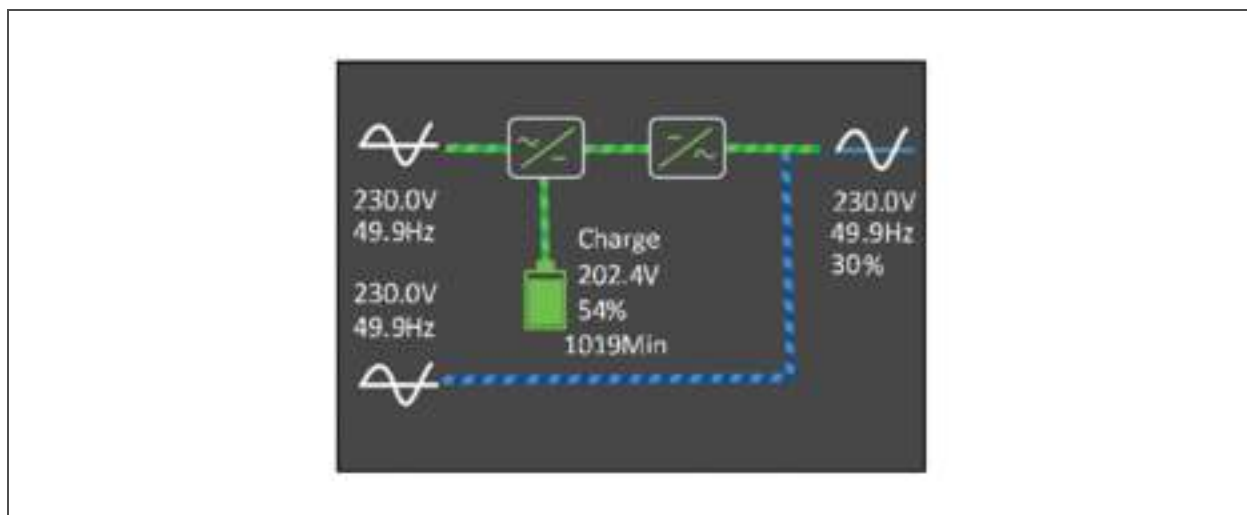

4.2.2 Main Menu

To access the main menu, press **Enter** while at the flow screen. **Table 4.3** on the next page, describes the menu options, and **Figure 4.4** on the next page, describes the display.

Use the arrow buttons to select the sub-menu options, and press **Enter** to open the sub menu. Press **ESC** to return to the flow.

Table 4.3 Menu Options

SUB MENU	DESCRIPTION
Status	Voltage, current, frequency, and parameters for UPS components, see Status Screen on the next page.
Settings	Display and system parameter settings, see Settings Submenu on page 45.
Control	UPS controls, see Control Screen on page 45.

Table 4.3 Menu Options (continued)

SUB MENU	DESCRIPTION
Log	Current alarms and event history, see Log Screen on page 46.
About	Product and network information, see About Screen on page 50.
Maintain	Service-only, proprietary-password-protected page for use only by Vertiv service representatives.

Figure 4.4 Main Menu



ITEM	DESCRIPTION
1	ECO-mode indicator
2	Ambient temperature and humidity. Only displays when sensors are connected.
3	Date and time

Status Screen

The status screen displays voltages, currents, frequencies, and parameters on individual tabs for input, bypass, battery, output, and load status.

To view the UPS status information:

1. At the main menu, select the Status icon, and press **Enter**.
2. Use the arrow buttons to move the cursor left/right and select a tab, then press **Enter** to display the status information for the selected tab.

Figure 4.5 Status-screen tabs

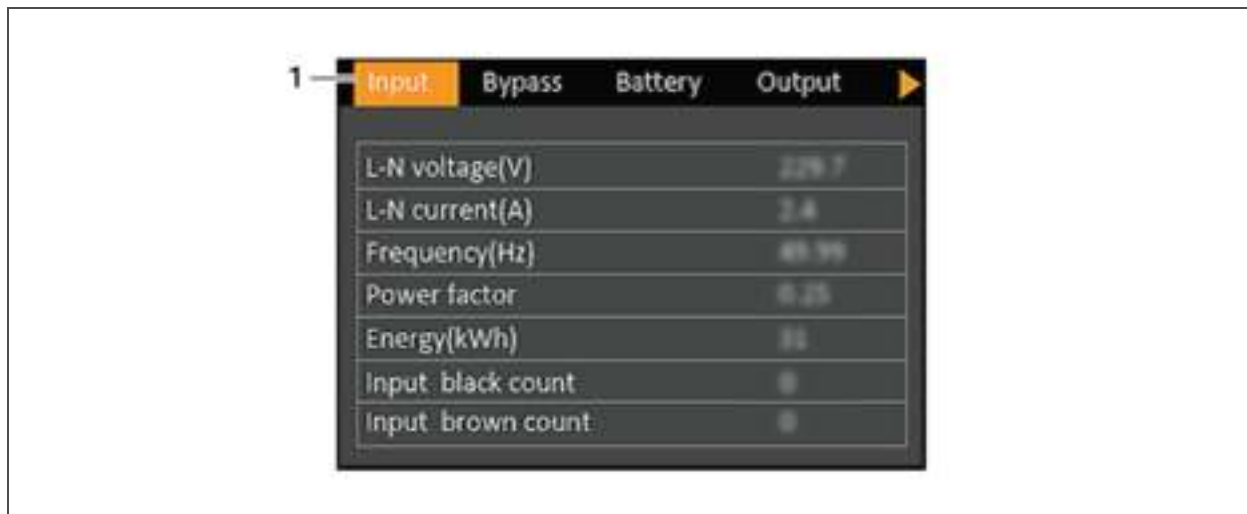

ITEM	DESCRIPTION
1	Screen tabs with Input tab selected.

Settings Submenu

The settings screen consists of tabs that list UPS settings for configuration and adjusting parameters with tabs for:

- Output
- Battery
- Parallel
- Monitoring

NOTE: To adjust the settings, you must enter a password. See [Editing Display and Operation Settings](#) on page 51, for details on entering the password and editing the setting parameters.

NOTE: Do not change parameter settings or reset to factory defaults when powering-off the UPS.

To modify UPS settings:

1. At the main menu, select the Settings icon, and press **Enter**.
2. Use the arrow buttons to move the cursor left/right and select a tab, then press **Enter** to display the parameter list for the selected tab.

Control Screen

The Control screen offers UPS-control options. [Figure 4.6](#) on the next page, shows an example.

To adjust the UPS controls:

1. At the main menu, select the Control icon, and press **Enter**.
2. Use the arrow buttons to move the cursor to the option, then press **Enter** to selected the control.

Figure 4.6 Control Screen

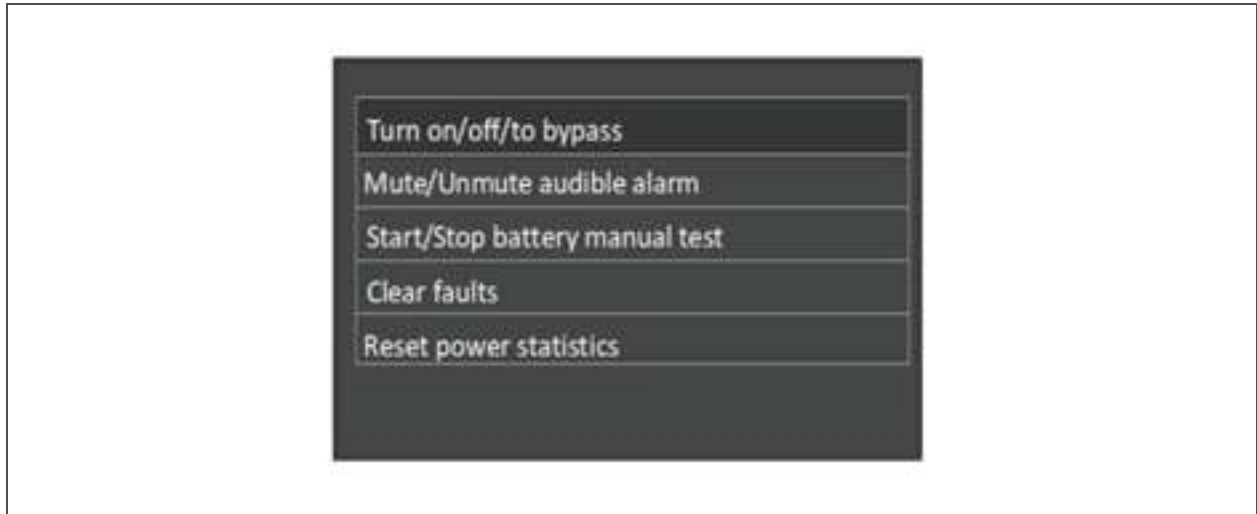

Log Screen

The Log Screen offers tabs that list the current alarms and the alarm/event history. Table 4.4 on page 50, describes the alarm messages you may see in the logs.

To view the logs:

1. At the main menu, select the Log icon, and press **Enter**.
2. Use the arrow buttons to move the cursor left/right and select a tab, then press **Enter** to display the log for the selected tab.

Figure 4.7 Current and History Log Tabs

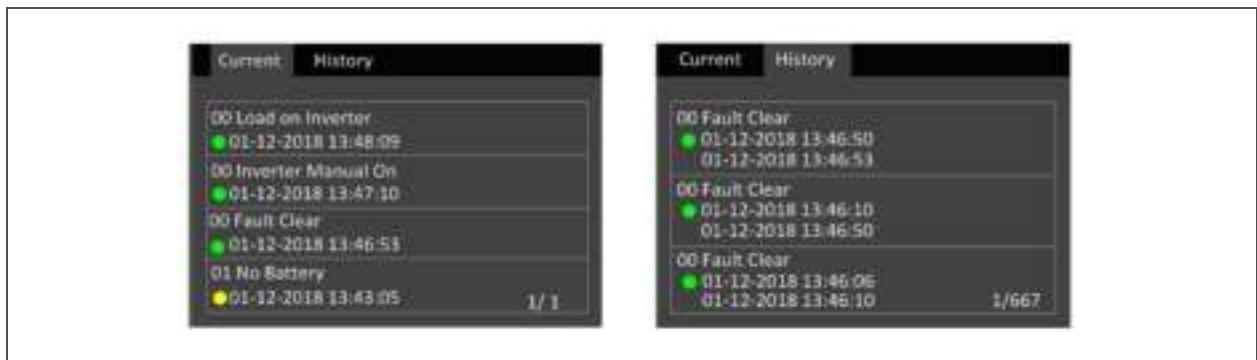

Table 4.4 Alarm-message descriptions

MESSAGE	DESCRIPTION
Communication fail	Internal communication is abnormal, please check the communication cables are connected correctly or not
Rectifier fault	The rectifier is faulty and off
DC/DC fault	The discharger is faulty, because the bus voltage exceeds the setting range when discharger starts or soft starts

Table 4.4 Alarm-message descriptions (continued)

MESSAGE	DESCRIPTION
DC bus abnormal	The inverter is off when DC bus voltage is faulty. The load will transfer to bypass if the bypass is available
Charger fault	The charger output voltage is abnormal, and the charger is off
Aux. power fault	The auxiliary power output voltage exceeds the normal range
Inverter fault	The inverter is off when the inverter output voltage and current exceed the setting range. If bypass is available, the UPS will transfer to bypass mode, otherwise the system will power off
Output short	Check that the output cables are not shorted
Bypass backfeed	Battery mode. The bypass relay is shorted or the SCR is damaged
Output off, voltage is not zero	When there is no output, the system detects that the output has a voltage
Inverter relay welded	The inverter relay is shorted
Parallel No. abnormal	The parallel online number is different from the setting number. Please check that the parallel number at 'Settings' page is the same as the actual online number, and that the parallel cables are normal
Parallel comm fault	The local UPS and its online frequency configuration is different or the parallel address is conflicted. Please check that the parallel system parameter setting is the same as the local parameter setting
Parallel cable connection abnormal	Detect the parallel cables are loosened
Input neutral lost	The AC input mains N line is not detected. Please check that the input N line is opened or loosened
Input abnormal	The rectifier and charger are off due to the mains voltage and frequency exceeding normal range. Check that the rectifier input phase voltage and frequency exceed the normal range or that the mains has power-off
Rectifier overload	The output power is larger than the rectifier overload point. Check that the input voltage meets the output load, mains input 176 V ~ 100 V, the load 100% ~ 50% linear derating
Battery reversed	The battery positive and negative are reversed. Please reconnect the battery and check the battery cables connection
Battery low pre-warning	This alarm occurs when the battery reaches the EOD. After the pre-warning, the battery capacity allows two minutes discharge at full load. The user can set the time ranging from 2 min ~ 30 min, (2 min by default). Please shut down the load timely
Battery voltage abnormal	When battery is connected, the system checks that the battery voltage exceeds the normal setting range. Check that the battery terminal voltage exceeds the normal range
No battery	Check the battery and battery cables connection
Battery test fail	The battery low voltage is detected when the battery has manual or periodical self-test. Battery replacement is recommended
Battery overtemp	Battery ambient temperature too high. Check that the battery ambient temperature is higher than setting value 40 ~ 60°C (default: 50°C)
Fan fault	At least one fan is faulty. Check that the fan is blocked or the cables connection is loosened

Table 4.4 Alarm-message descriptions (continued)

MESSAGE	DESCRIPTION
System overtemp	Internal heat sink temperature too high, and the inverter is off. Only each module heat sink temperature decreased to the setting value can you silence the alarm. The system can automatically start after overtemperature fault is solved. If overtemperature, please check: 1. Ambient temperature too high or not 2. Dust is blocked or not 3. Fan fault or not
Inverter overload	Inverter load capacity is larger than the rated value, overload delay time is up, inverter shuts down. If bypass is available, the system will transfer to the bypass mode, otherwise the output is failure. Check that the actual inverter load capacity, if overloaded, just reduce the load capacity, and the system will transfer to the inverter mode after five seconds with alarm cleared
Bypass overcurrent	The bypass current exceeds the rated value.
Bypass abnormal	Maybe caused by bypass voltage and frequency outside of range, bypass power-off and incorrect bypass cables connection. 1. Check that the bypass voltage and frequency are within the setting range. 2. Check the bypass cables connection
Bypass abnormal in ECO mode	The ECO mode is available, and the bypass voltage and frequency are outside of the setting range. Check that the bypass input voltage and frequency are within the setting range
Output LPE short	The output and enclosure are shorted. Check whether the output cables connection and the enclosure are shorted or not
Output pending	Remote shutdown is enabled, and the system will be off
Output disabled	The system is in standby state, and the dry contact shutdown is enabled. Check whether the shutdown dry contact is enabled or not
On maintenance bypass	The dry contact in maintenance bypass state is activated
Battery mode	The UPS is on battery, and the inverter starts
Bypass mode	The UPS is on bypass
System overload	The parallel system load capacity is larger than the max. load capacity output by parallel sets. Confirm the parallel system load capacity, if overloaded, just reduce it
Loss of redundancy	After the parallel redundancy is enabled, the system load capacity is larger than the rated load of (online set minus one)
Load sharing abnormal	Load sharing is abnormal in parallel system
System parallel settings sync	Check that parallel setting parameters of each unit are the same
Local parallel settings async	Check that the Settings page is the same between this local unit and other units
REPO	Shutdown caused by the REPO terminal Normally Closed contact open
System battery low pre-warning	In parallel system, all the devices powered by the battery inverter have battery low voltage pre-warning
Battery test started	The battery periodic self-test and manual self-test started
Battery test stopped	The battery periodic self-test or manual self-test finished

Table 4.4 Alarm-message descriptions (continued)

MESSAGE	DESCRIPTION
EOD turn off	The inverter is off due to EOD. Check the mains power-off state and recover the mains in time
Guaranteed shutdown	Under forced EOD mode, the battery discharging finished, then system shuts down
Shutdown due to overtemp	During the UPS operation, the system checks that the heat sink temperature exceeds the setting range. If overtemperature, please check: 1. Ambient temperature too high or not 2. Dust is blocked or not 3. Fan fault or not
Remote shutdown	Dry contact activated at any mode shutdown
Remote power-on	Remotely power on
Remote shut-off	Remotely power off
Load off due to shutdown on battery	Shutdown in battery mode
Output off due to bypass abnormal	The bypass is abnormal, and the bypass is in standby state from working state. Check that the bypass input is normal
Battery to utility transition	The UPS is powered by the mains instead of the battery
Manual power-on	Set power-on via LCD panel
Manual shutdown	Set shutdown via LCD panel
Operating on inverter	The UPS output state is on inverter
Restore factory defaults	Under UPS stand-by state, set 'Restore Factory Defaults' function via the Maintain page
System parallel settings start sync	Manually set the 'Sync parallel parameters' command to activate the event
Local settings sync OK	Local parameters are successfully synchronized
System settings sync OK	All the parameters are successfully synchronized
Load off due to output short	The inverter short circuit or the bypass short circuit. Please check it
Output off due to overload & bypass abnormal	The output is off due to output overload and bypass abnormal. Please check it
Input phase reversed	the input live line and N line are connected incorrect
Turn on fail	UPS get the command of start. and the mains voltage not exist or greater than 188 V, confirm 2 circulation. the prompt will appear
Input backfeed	When the battery voltage is larger than 100 V, the absolute value of the difference between any phase utility voltage and battery voltage is larger than 10 V. - in such a scenario, a time frame of 6 seconds is required for confirming and ensuring that the fault has indeed occurred

Table 4.4 Alarm-message descriptions (continued)

MESSAGE	DESCRIPTION
Insufficient capacity to start	The UPS is on bypass, UPS get the command of start, the system load capacity is larger than 105% rated . the prompt will appear
UPS has no output	Both Inverter and Bypass provide no power supply.
Battery replacement timeout	The alarm will appear when the time (Battery replaced time adds the noted time of battery replacement) later than the current system time. When the users set the noted time of battery replacement as disabled, the alarm will not appear.

About Screen

The About screen offers tabs that list information about the product and the network.

To view the product and network information:

1. At the main menu, select the Settings icon, and press **Enter**.
2. Use the arrow buttons to move the cursor left/right and select a tab, then press **Enter** to display the information for the selected tab.

Figure 4.8 About Screen Tabs

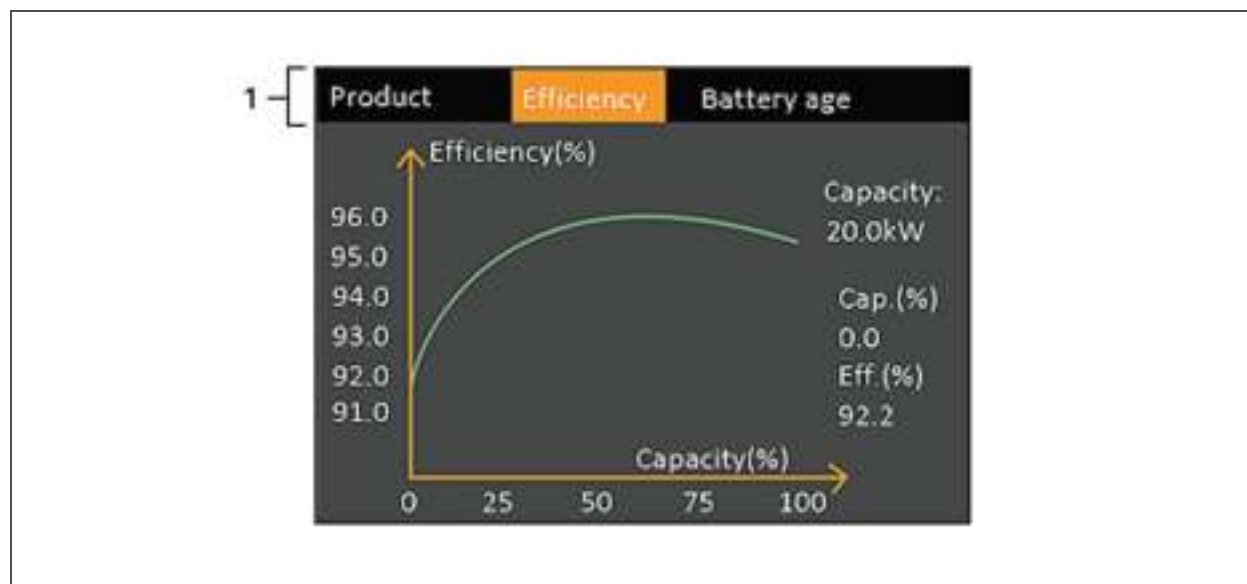

ITEM	DESCRIPTION
1	Screen tabs with Efficiency tab selected.

4.3 Editing Display and Operation Settings

You may adjust the display settings and UPS configuration via the LCD. The display and operation settings are password protected. The default password is 111111 (six ones).

NOTE: We recommend that you change the password to protect your system and equipment and record the new password and store it in an accessible location for later retrieval. See [Changing the Password](#) below.

To enter the password:

1. Press the up-arrow button to change the digit, then press the down-arrow button to move to the next digit.
2. Repeat to select each digit, and press **Enter** to submit the password.

Figure 4.9 Password Prompt



4.3.1 Changing the Password

The default password is 111111 (six ones). You must use the current password to change the password.

NOTE: We recommend that you change the password from the default to protect your system and equipment. Record the new password and store it in an accessible location for later retrieval.

1. At the main menu, select the Settings icon, and press **Enter**.
2. At the password prompt, use the up-arrow to select the first digit, press the down-arrow to move to the next digit, repeat for each digit, then press **Enter** to access the settings.
3. Use the arrow buttons to select the Monitor tab, then press **Enter**.

4. Use the down arrow to highlight *Change Settings Password*, press **Enter**, and re-enter the current password.
The Input new password dialog opens, see Figure 4.10 below.
5. Enter the new password, then confirm the new password.
A confirmation dialog opens to indicate a successful password change.
6. Press ESC to return to the settings or main menu.

Figure 4.10 New and Confirm Password dialogs



4.3.2 Selecting the Display Language

The LCD is multilingual. The available languages are English, French, Portuguese, Spanish, Chinese, German, Japanese, and Russian.

To change the language:

1. At the main menu, select the Settings icon, and press **Enter**.
2. At the password prompt, use the up-arrow to select the first digit, press the down-arrow to move to the next digit, repeat for each digit, then press **Enter** to access the settings.
3. Use the arrow buttons to select the Monitor tab, then press **Enter**.
4. Use the down arrow to highlight *Language*, then press **Enter**.
5. Use the up/down arrows to select the language, then press **Enter**.
All the LCD elements display in the selected language.

4.3.3 Setting the Date and Time

To adjust the date and time:

1. At the main menu, select the Settings icon, and press **Enter**.
2. At the password prompt, use the up-arrow to select the first digit, press the down-arrow to move to the next digit, repeat for each digit, then press **Enter** to access the settings.
3. Use the arrow buttons to select the Monitor tab, then press **Enter**.
4. Use the down arrow to highlight *Date* or *Time*, then press **Enter**.
5. Use the up/down arrows to select the date/time, then press **Enter** to confirm.

5 MAINTENANCE



WARNING! Risk of electric shock. Can cause equipment damage, injury and death. A battery can present a risk of electrical shock and high short-circuit current.

Observe the following precautions when working on batteries:

- Remove watches, rings and other metal objects.
- Use tools with insulated handles.
- Wear rubber gloves and boots.
- Do not lay tools or metal parts on top of batteries.
- Disconnect charging source prior to connecting or disconnecting battery terminals.
- If the battery kit is damaged in any way or shows signs of leakage, contact your Vertiv representative immediately.
- Handle, transport, and recycle batteries in accordance with local regulations.
- Determine if the battery is inadvertently grounded. If it is inadvertently grounded, remove the source of the ground. Contact with any part of a grounded battery can result in electrical shock. The likelihood of such shock will be reduced if grounds are removed during installation and maintenance (applicable to a UPS and a remote battery supply not having a grounded supply circuit).

5.1 Replacing Batteries



WARNING! Risk of electric shock. Can cause injury or death. Disconnect all local and remote electric power supplies before working with the UPS. Ensure that the unit is shut down and power has been disconnected before beginning any maintenance.



WARNING! Risk of electric shock and explosion. Can cause equipment damage, injury and death. Do not dispose of the battery in a fire. The battery may explode. Do not open or damage the battery. Released electrolyte is toxic and is harmful to skin and eyes. If electrolyte comes into contact with the skin, wash the affected area immediately with plenty of clean water and get medical attention.



WARNING! Risk of electric shock. Can cause equipment damage, injury and death. A battery can present a risk of electrical shock and high short-circuit current.



WARNING! Risk of explosion. Can cause equipment damage, injury and death. A battery can explode if the battery is replaced by an incorrect type. Dispose of used batteries according to the instructions included with the battery-pack.

Read all safety cautions before proceeding. A trained user can replace the internal battery pack when the UPS is in a restricted access location (such as a rack or server closet). To obtain the appropriate replacement battery pack(s), refer to **Table 5.1** below, and contact your local dealer or Vertiv representative.

Table 5.1 Replacement Battery-pack Model Numbers

UPS MODEL NUMBER	BATTERY PACK MODEL NUMBER	QUANTITY REQUIRED
GXT5-5000IRT5UXLN	GXT5-192VBatkit	1
GXT5-5000IRT5UXLE		
GXT5-5000HVRT5UXLN		
GXT5-6000IRT5UXLN		
GXT5-6000IRT5UXLE		
GXT5-8000IRT5UXLN	GXT5-192VBatkit	1
GXT5-8000IRT5UXLE		
GXT5-8000HVRT5UXLN		
GXT5-10KIRT5UXLN		
GXT5-10KIRT5UXLE		
GXT5-10KHVRT5UXLN	GXT5-192VBatkit	2
GXT5-16KIRT9UXLN		
GXT5-16KIRT9UXLE		
GXT5-20KIRT9UXLN		
GXT5-20KIRT9UXLE		

To replace a battery pack:

NOTE: The internal battery pack is hot-swappable. However, you must exercise caution because; during this procedure, the load is unprotected from disturbances and power outages. Do not replace the battery while the UPS is operating in Battery Mode. This will result in a loss of output power and will drop the connected load.

1. Remove the front cover from the UPS, then loosen and remove the screws on the battery door, see **Figure 5.1** on the facing page.
2. Lay the cover, battery door, and screws aside for reassembly.
3. Grasp the battery handle, and pull out each battery pack to be replaced, see **Figure 5.1** on the facing page.
4. Unpack the replacement battery pack, taking care not to damage the packaging to re-use when disposing of the old battery.
5. Compare the new and old battery pack to make sure they are the same type and model. If so, proceed with step 6. If they are different, stop and contact your Vertiv representative, or Technical Support, <http://www.VertivCo.com/en-us/support/>.

6. Line-up and slowly push-in each replacement battery pack. until 2/3 of the length is in the bay, then lift up and continue to push smoothly until the battery pack is fully inserted in the bay. The battery is fully-inserted if the battery door fits flush against the UPS.
7. Re-attach the battery door with the screws, and replace the front cover.
8. Activate the new battery pack(s) using the operating/display panel:

NOTE: The display menus and functions are described in [Operation and Display Panel](#) on page 41.

- From the main menu, select *Settings*, then the Monitoring tab and verify that the date and time are correct. If the date or time need correction, see [Setting the Date and Time](#) on page 52.
- Select the *Battery* tab, use the arrows to select Replace Battery, and press **Enter**. The replaced battery packs are activated.
- Use **ESC** to return to the main display.

Figure 5.1 Replacing the Battery Pack

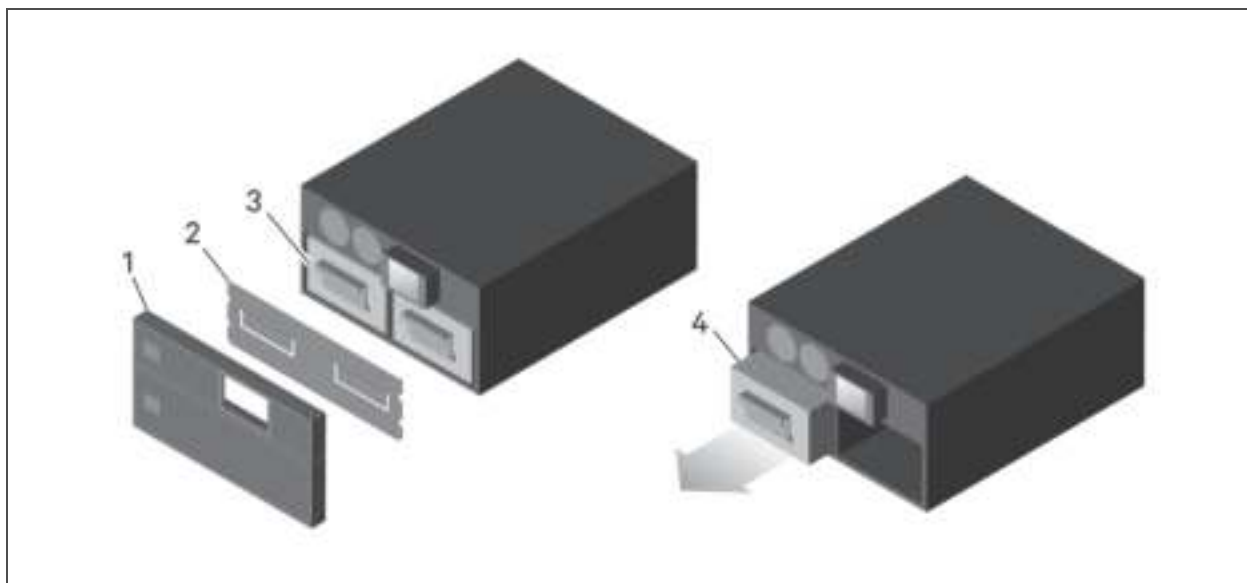

ITEM	DESCRIPTION
1	Front cover
2	Battery door
3	Battery handle
4	Grasp handle and pull battery out.

5.2 Charging Batteries

The batteries are valve-regulated, non-spillable, lead acid and should be kept charged to attain their design life. The UPS charges the batteries continuously when it is connected to the utility input power.

If the UPS will be stored for a long time, We recommend connecting the UPS to input power for at least 24 hours every 4 to 6 months to ensure full recharge of the batteries.

5.3 Checking UPS Operation

NOTE: Operation-check procedures may interrupt power supply to the connected load.

We recommend checking the UPS operation once every 6 months.

Back-up the load data before conducting the check.

1. Press the power button to check the indicators and display function.
2. Check for alarm or fault indicators on the operation/display panel.
3. Make sure that there are no audible or silenced alarms.
4. Select the Setting menu, and look at the log for alarm and fault history.
5. Check the operating mode for Normal mode. If the UPS is operating in Bypass mode, contact Vertiv Technical Support.
6. Check to see if batteries are discharging (operating in Battery mode) and utility power is normal. If so, contact Vertiv Technical Support.

5.4 Cleaning the UPS



WARNING! Risk of electric shock. Can cause injury or death. Disconnect all local and remote electric power supplies before working with the UPS. Ensure that the unit is shut down and power has been disconnected before beginning any maintenance.

The UPS requires no internal cleaning. If the outside of the UPS becomes dusty, wipe with a dry cloth. Do not use liquid or aerosol cleaners. Do not insert any objects into the ventilation holes or other openings in the UPS.

5.5 Removing the Power-distribution Box

1. Transfer the connected equipment to the internal bypass.

NOTE: The programmable-output receptacles are powered-off when transferred to Bypass mode.

- a. Loosen the upper captive screw over the maintenance bypass breaker, see **Figure 5.2** on the facing page.
- b. Lift the maintenance-bypass breaker cover up, and tighten the lower captive screw. The programmable-output receptacles are now powered-off.
2. Confirm that the UPS is operating in bypass mode. If not, then manually transfer the connected equipment to bypass as follows:
 - a. From the main menu select CONTROL, then press **Enter**.
 - b. Select *Turn on/off/to bypass* and press **Enter**.
 - c. Select *Turn to bypass* and press **Enter**.

NOTE: The load is unprotected from disturbances in the power supply while the UPS is on bypass.

3. Turn the maintenance-bypass breaker On.
4. Wait 1 minute if the UPS is working on battery mode, then confirm that the UPS is turned-off.
5. Turn the output and input breakers Off. On 8-kVA and 10-kVA models, also turn off the bypass breaker.
6. Loosen other captive screws until the power-distribution box releases.

7. Remove the power distribution box from the UPS and set it aside.
8. On the rear of the panel, loosen the screws of the protective cover for the connectors, slide it over the connectors, and tighten the screws.

NOTE: The captive screws and maintenance-bypass breaker cover is similar for all 5- to 10-kVA models. **Figure 5.2** below, shows an example on the 5-kVA/6-kVA model.

Figure 5.2 Maintenance-bypass Breaker Cover and Captive Screws

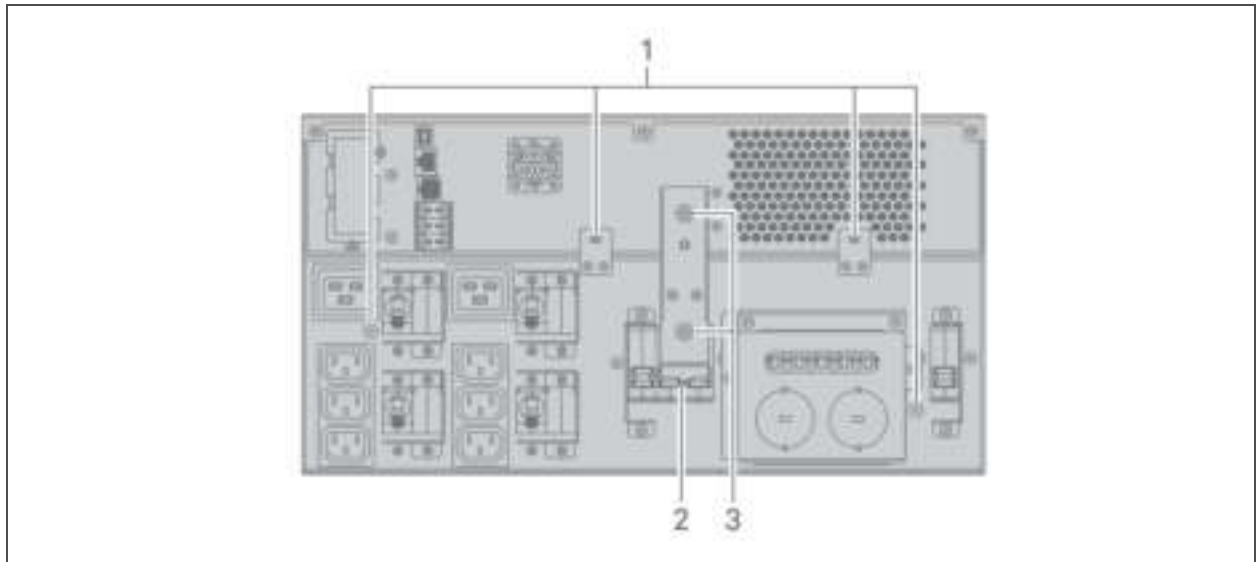

ITEM	DESCRIPTION
1	Captive screws for POD
2	Maintenance-bypass breaker
3	Connector-cover screws

This page intentionally left blank

6 TROUBLESHOOTING

This section indicates various UPS symptoms you may encounter and provides a troubleshooting guide in the event the UPS develops a problem. Use the following information to determine whether external factors caused the problem and how to remedy the situation.

6.1 Symptoms that Require Troubleshooting

The following symptoms indicate the UPS is malfunctioning:

- The relative indicators illuminate, indicating the UPS has detected a problem.
- An alarm buzzer sounds, alerting the user that the UPS requires attention.

6.2 Audible Alarm (Buzzer)

An audible alarm accompanies various events during UPS operations. **Table 6.1** below, describes the sounds and their meaning. To silence an alarm, see [Silencing the Audible Alarm](#) on page 39.

Table 6.1 Audible-alarm Descriptions

SOUND	INDICATES:
Continuous beep	Generated when a UPS fault appears, such as a fuse or hardware failure.
One beep every 0.5 seconds	Generated when a UPS critical alarm appears, such as on inverter overload.
One beep every 1 second	Generated when a UPS critical alarm appears, such as on battery low voltage.
One beep every 3.3 seconds	Generated when a UPS general alarm appears.

NOTE: When an alarm is indicated, an alarm message is logged. **Table 4.4** on page 50, describes the alarm messages you may see. When a fault is indicated, front-panel display list the fault, which are described in **Table 6.2** on the next page.

6.2.1 Faults

When the fault indicator is illuminated, the LCD displays the fault. The faults are described in **Table 6.2** on the next page.

Table 6.2 Description of displayed faults

DISPLAYED FAULT	CAUSE	CORRECTIVE STEPS
Battery test fail	The battery is bad or weak.	Contact technical support.
Rectifier fault	A rectifier failure occurred.	Contact technical support.
Inverter overload, Bypass overcurrent	The UPS is overloaded, Bypass is over current.	Reduce the load and contact technical support.
Inverter fault	The inverter is faulty.	Contact technical support.
Battery aged	The battery is bad or weak.	Replace the battery.
Output short	The output connection is short-circuited.	Shut-down the equipment and contact technical support.
DC bus fail	The DC bus is faulty.	Contact technical support.

Table 6.2 Description of displayed faults (continued)

DISPLAYED FAULT	CAUSE	CORRECTIVE STEPS
System overtemp	Over-temperature condition in the UPS. The UPS will transfer to bypass mode.	Reduce the load and contact technical support.
Charger fault	The charger is faulty.	Contact technical support.
Fan fault	At least one fan is faulty.	Contact technical support.
DC/DC fault	A DC-DC charger failure occurred.	Contact technical support.

6.3 Troubleshooting UPS Issues

In the event of an issue with the UPS, refer to **Table 6.3** below, to determine the cause and solution. If the fault persists, contact Vertiv Technical Support. Visit the GXT5 product page at www.VertivCo.com for contact information.

When reporting a UPS issue to Vertiv, include the UPS model and serial number. These are located in several places for your ease of location:

- on the top panel (rack mount orientation)
- the left side (tower orientation)
- the rear panel
- on the front of the unit behind the front plastic bezel
- on the LCD select *Main Menu > About*.

Table 6.3 Troubleshooting

PROBLEM	CAUSE	SOLUTION
UPS fails to start	UPS is short-circuited or overloaded	Ensure UPS is Off. Disconnect all loads and ensure nothing is lodged in output receptacles. Ensure loads are not defective or shorted internally.
	Batteries are not charged enough or not connected	Check to ensure the internal battery is connected. If it is not, make the connection and try to start the unit. If the battery is connected, leave the UPS connected to input power for 24 hours to recharge batteries, then try to start the unit.
UPS has reduced battery backup time	Batteries are not fully charged	Keep UPS plugged in continuously at least 24 hours to recharge batteries.
	UPS is overloaded	Check load level indicator and reduce the load on the UPS.
	Batteries may not be able to hold a full charge due to age	Replace batteries. Contact your Vertiv representative or Vertiv Technical Support for replacement battery kit.

7 SPECIFICATIONS

Table 7.1 UPS Specifications, 5-kVA and 6-kVA models

MODEL: GXT5-	5000IRT5UXLN	5000IRT5UXLE	5000HVRT5UXLN	6000IRT5UXLN	6000IRT5UXLE
RATING	5000 VA/5000 W			6000 VA/6000 W	
Dimensions, mm (in.)					
Unit, WxDxH	430×630×217(16.9×24.8×8.5)				
Shipping, WxDxH	646×816×520(25.4×32.1×20.5)				
Weight, kg (lb)					
Unit	70.8 (156)		71.1(156.7)	70.8 (156)	
Shipping	92(202.8)	89 (196.2)	92(202.8)	92(202.8)	89 (196.2)
Input AC Parameters					
Operating Frequency, Nom.	50 or 60 Hz (factory-default is 50 Hz)				
Factory-default VAC	230 VAC				
User-configurable VAC	200/208/220/230/240 VAC (Adjustable using operation/display configuration options)				
Operating voltage range without battery operation	176 – 288 VAC (100 – 176 VAC with power derating)				
Maximum Allowable VAC	288 VAC				
Input frequency without battery operation	40 – 70 Hz				
Input Power Connection	PD5-CE6HDWRMBS		PD5-CE6HDWRMBSU		PD5-CE6HDWRMBS
Output AC Parameters					
AC-AC Efficiency	94%				
Factory-default VAC Frequency	230 VAC, 50 Hz				
Output Power Connection	PD5-CE6HDWRMBS		PD5-CE6HDWRMBSU		PD5-CE6HDWRMBS
Waveform	Sinewave				
Main Mode Overload	> 150% minimum 200 mS, 125 – 150% for 60 seconds; 105 – 125% for for 5 minutes; ≤ 105% continuous				
Internal Battery Charger					
Charger Current, A	2.25 A (default), maximum 5 A				

Table 7.1 UPS Specifications, 5-kVA and 6-kVA models (continued)

MODEL: GXT5-	5000IRT5UXLN	5000IRT5UXLE	5000HVRT5UXLN	6000IRT5UXLN	6000IRT5UXLE
RATING	5000 VA/5000 W			6000 VA/6000 W	
Battery Parameters					
Type	Valve-regulated, non-spillable, lead acid				
Quantity x Voltage x Rating	16 x 12V x 9.0AH				
Battery Mfr./Part #	9AH; LEOCH/DJW12-9.0				
Back-up time	See Table 7.11 on page 71.			See Table 7.10 on page 71.	
Upper-limit selections	+10%, +15%, +20%; default +10%.				
Lower-limit selections	-10%, -15%, -20%; default -15%				
Disable-bypass operation	When the input frequency prevents synchronous operation.				
Environmental					
Operating Temperature, °C (°F)	0 to 40 (32 to 104) (no derating)				
Storage Temperature, °C (°F)	-15 to 40 (5 to 104)				
Relative Humidity	0 – 95% non-condensing				
Operating Elevation	Up to 3,000 m (9,842.5 ft) at 25°C (77°F) without derating				
Audible Noise	<55 dBA, at 1 meter from the front, <50 dBA, at 1 meter from rear or sides				
Agency					
Safety	IEC62040-1:2008 version, GS mark	IEC62040-1:2008 version, GS mark; UL1778, c-UL listed	IEC62040-1:2008 version, GS mark; UL1778, c-UL listed	IEC62040-1:2008 version, GS mark	IEC62040-1:2008 version, GS mark
EMI/EMC/C-Tick EMC	IEC/EN/AS 62040-2 2nd Ed (Cat 2 – Table 6)	IEC/EN/AS 62040-2 2nd Ed (Cat 2 – Table 6); FCC Part 15 (Class A) CISPR22 Class A (RFI)	IEC/EN/AS 62040-2 2nd Ed (Cat 2 – Table 6); FCC Part 15 (Class A) CISPR22 Class A (RFI)	IEC/EN/AS 62040-2 2nd Ed (Cat 2 – Table 6)	IEC/EN/AS 62040-2 2nd Ed (Cat 2 – Table 6)
ESD	IEC/EN EN61000-4-2, Level 4, Criteria A	IEC/EN EN61000-4-2, Level 4, Criteria A	IEC/EN EN61000-4-2, Level 4, Criteria A	IEC/EN EN61000-4-2, Level 4, Criteria A	IEC/EN EN61000-4-2, Level 4, Criteria A
Radiated Susceptibility	IEC/EN EN61000-4-3, Level 3, Criteria A	IEC/EN EN61000-4-3, Level 3, Criteria A	IEC/EN EN61000-4-3, Level 3, Criteria A	IEC/EN EN61000-4-3, Level 3, Criteria A	IEC/EN EN61000-4-3, Level 3, Criteria A
Electrical Fast Transient	IEC/EN EN61000-4-4, Level 4, Criteria A	IEC/EN EN61000-4-4, Level 4, Criteria A	IEC/EN EN61000-4-4, Level 4, Criteria A	IEC/EN EN61000-4-4, Level 4, Criteria A	IEC/EN EN61000-4-4, Level 4, Criteria A
Surge Immunity	IEC/EN EN61000-4-5, Level 4, Criteria A	IEC/EN EN61000-4-5, Level 4, Criteria A; ANSI C62.41 Category B	IEC/EN EN61000-4-5, Level 4, Criteria A; ANSI C62.41 Category B	IEC/EN EN61000-4-5, Level 4, Criteria A	IEC/EN EN61000-4-5, Level 4, Criteria A
Transportation	ISTA Procedure 1E				

Table 7.2 UPS Specifications, 8-kVA and 10-kVA models

MODEL: GXT5-	8000IRT5UXLN	8000IRT5UXLE	8000HVRT5UXLN	10KIRT5UXLN	10KIRT5UXLE	10KHVRT5UXLN
RATING	8000 VA/8000 W			10000 VA/10000 W		
Dimensions, mm (in.)						
Unit, WxDxH	430×630×217(16.9×24.8×8.5)					
Shipping, WxDxH	646×816×520(25.4×32.1×20.5)					
Weight, kg (lb)						
Unit	74.5 (164.2)		75.5 (166.4)	74.5 (164.2)		75.5 (166.4)
Shipping	95 (209.4)	93 (205)	94 (207.2)	95 (209.4)	93 (205)	94 (207.2)
Input AC Parameters						
Operating Frequency, Nom.	50 or 60 Hz (factory-default is 50 Hz)					
Factory-default VAC	230 VAC					
User-configurable VAC	200/208/220/230/240 VAC (Adjustable using operation/display configuration options)					
Operating voltage range without battery operation	176 – 288 VAC (100 – 176VAC with power derating)					
Maximum Allowable VAC	288 VAC					
Input frequency without battery operation	40 – 70 Hz					
Input Power Connection	PD5-CE10HDWRMBS	PD5-CE10HDWRMBSU	PD5-CE10HDWRMBS	PD5-CE10HDWRMBS	PD5-CE10HDWRMBS	PD5-CE10HDWRMBSU
Output AC Parameters						
AC-AC Efficiency	94.5%			95%		
Factory-default VAC Frequency	230 VAC, 50 Hz					
Output Power Connection	PD5-CE10HDWRMBS	PD5-CE10HDWRMBSU	PD5-CE10HDWRMBS	PD5-CE10HDWRMBS	PD5-CE10HDWRMBS	PD5-CE10HDWRMBSU
Waveform	Sinewave					
Main Mode Overload	> 150% minimum 200 mS, 125 – 150% for 60 seconds; 105 – 125% for 5 minutes; ≤ 105% continuous					
Internal Battery Charger						
Charger Current, A	2.25 default, maximum 8 Amps					

Table 7.2 UPS Specifications, 8-kVA and 10-kVA models (continued)

MODEL: GXT5-	8000IRT5UXLN	8000IRT5UXLE	8000HVRT5UXLN	10KIRT5UXLN	10KIRT5UXLE	10KHVRT5UXLN
RATING	8000 VA/8000 W			10000 VA/10000 W		
Battery Parameters						
Type	Valve-regulated, non-spillable, lead acid					
Quantity x Voltage x Rating	16 x 12V x 9.0AH					
Battery Mfr./Part #	9AH; LEOCH/DJW12-9.0					
Back-up time	See Table 7.9 on page 70.			See Table 7.8 on page 70.		
Upper-limit selections	+10%, +15%, +20%; default +10%.					
Lower-limit selections	-10%, -15%, -20%; default -15%					
Disable-bypass operation	When the input frequency prevents synchronous operation.					
Environmental						
Operating Temperature, °C (°F)	0 to 40 (32 to 104) (no derating)					
Storage Temperature, °C (°F)	-15 to 40 (5 to 104)					
Relative Humidity	0 – 95% non-condensing					
Operating Elevation	Up to 3,000 m (9,842.5 ft) at 25°C (77°F) without derating					
Audible Noise	<55 dBA, at 1 meter from the front, <50 dBA, at 1 meter from rear or sides					

Table 7.2 UPS Specifications, 8-kVA and 10-kVA models (continued)

MODEL: GXT5-	8000IRT5UXLN	8000IRT5UXLE	8000HVRT5UXLN	10KIRT5UXLN	10KIRT5UXLE	10KHVRT5UXLN
RATING	8000 VA/8000 W			10000 VA/10000 W		
Agency						
Safety	IEC62040-1:2008 version, GS mark	IEC62040-1:2008 version, GS mark; UL1778, c-UL listed	IEC62040-1:2008 version, GS mark	IEC62040-1:2008 version, GS mark	IEC62040-1:2008 version, GS mark	IEC62040-1:2008 version, GS mark; UL1778, c-UL listed
EMI/EMC/C-Tick EMC	IEC/EN/AS 62040-2 2nd Ed (Cat 2 – Table 6)	IEC/EN/AS 62040-2 2nd Ed (Cat 2 – Table 6); FCC Part 15 (Class A) CISPR22 Class A (RFI)	IEC/EN/AS 62040-2 2nd Ed (Cat 2 – Table 6)	IEC/EN/AS 62040-2 2nd Ed (Cat 2 – Table 6)	IEC/EN/AS 62040-2 2nd Ed (Cat 2 – Table 6)	IEC/EN/AS 62040-2 2nd Ed (Cat 2 – Table 6); FCC Part 15 (Class A) CISPR22 Class A (RFI)
ESD	IEC/EN EN61000-4-2, Level 4, Criteria A	IEC/EN EN61000-4-2, Level 4, Criteria A	IEC/EN EN61000-4-2, Level 4, Criteria A	IEC/EN EN61000-4-2, Level 4, Criteria A	IEC/EN EN61000-4-2, Level 4, Criteria A	IEC/EN EN61000-4-2, Level 4, Criteria A
Radiated Susceptibility	IEC/EN EN61000-4-3, Level 3, Criteria A	IEC/EN EN61000-4-3, Level 3, Criteria A	IEC/EN EN61000-4-3, Level 3, Criteria A	IEC/EN EN61000-4-3, Level 3, Criteria A	IEC/EN EN61000-4-3, Level 3, Criteria A	IEC/EN EN61000-4-3, Level 3, Criteria A
Electrical Fast Transient	IEC/EN EN61000-4-4, Level 4, Criteria A	IEC/EN EN61000-4-4, Level 4, Criteria A	IEC/EN EN61000-4-4, Level 4, Criteria A	IEC/EN EN61000-4-4, Level 4, Criteria A	IEC/EN EN61000-4-4, Level 4, Criteria A	IEC/EN EN61000-4-4, Level 4, Criteria A
Surge Immunity	IEC/EN EN61000-4-5, Level 4, Criteria A	IEC/EN EN61000-4-5, Level 4, Criteria A; ANSI C62.41 Category B	IEC/EN EN61000-4-5, Level 4, Criteria A	IEC/EN EN61000-4-5, Level 4, Criteria A	IEC/EN EN61000-4-5, Level 4, Criteria A	IEC/EN EN61000-4-5, Level 4, Criteria A; ANSI C62.41 Category B
Transportation	ISTA Procedure 1E					

Table 7.3 UPS Specifications, 16-kVA and 20-kVA models

MODEL: GXT5-	16KIRT9UXLN	16KIRT9UXLE	20KIRT9UXLN	20KIRT9UXLE
RATING	16000 VA/16000 W		20000 VA/20000 W	
Dimensions, mm (in.)				
Unit, WxDxH	430×630×394(16.9×24.8×15.5)			
Shipping, WxDxH	900×1200×700(35.4×47.2×27.6)			
Weight, kg (lb)				
Unit	135.2 (298)			
Shipping	190 (418.9)	186.7 (411.6)	190 (418.9)	186.7 (411.6)

Table 7.3 UPS Specifications, 16-kVA and 20-kVA models (continued)

MODEL: GXT5-	16KIRT9UXLN	16KIRT9UXLE	20KIRT9UXLN	20KIRT9UXLE
RATING	16000 VA/16000 W		20000 VA/20000 W	
Input AC Parameters				
Operating Frequency, Nom.	50 or 60 Hz (factory-default is 50 Hz)			
Factory-default VAC	230 VAC			
User-configurable VAC	200/208/220/230/240 VAC (Adjustable using operation/display configuration options)			
Operating voltage range without battery operation	176 – 288 VAC (100 – 176VAC with power derating)			
Maximum Allowable VAC	288 VAC			
Input frequency without battery operation	40 – 70 Hz			
Input Power Connection	Input terminal block			
Output AC Parameters				
AC-AC Efficiency	95%			
Factory-default VAC Frequency	230 VAC, 50 Hz			
Output Power Connection	Output terminal block			
Waveform	Sinewave			
Main Mode Overload	> 150% minimum 200 mS, 125 – 150% for 60 seconds; 105 – 125% for for 5 minutes; ≤ 105% continuous			
Internal Battery Charger				
Charger Current, A	2.25 (default), maximum 13 A			
Battery Parameters				
Type	Valve-regulated, non-spillable, lead acid			
Quantity x Voltage x Rating	32 x 12V x 9.0AH			
Battery Mfr./Part #	9AH; LEOCH/DJW12-9.0			
Back-up time	See Table 7.7 on page 69.		See Table 7.6 on page 69.	
Upper-limit selections	+10%, +15%, +20%; default +10%.			
Lower-limit selections	-10%, -15%, -20%; default -15%			
Disable-bypass operation	When the input frequency prevents synchronous operation.			

Table 7.3 UPS Specifications, 16-kVA and 20-kVA models (continued)

MODEL: GXT5-	16KIRT9UXLN	16KIRT9UXLE	20KIRT9UXLN	20KIRT9UXLE
RATING	16000 VA/16000 W		20000 VA/20000 W	
Environmental				
Operating Temperature, °C (°F)	0 to 40 (32 to 104) (no derating)			
Storage Temperature, °C (°F)	-15 to 40 (5 to 104)			
Relative Humidity	0 – 95% non-condensing			
Operating Elevation	Up to 3,000 m (9,842.5 ft) at 25°C (77°F) without derating			
Audible Noise	<58 dBA, at 1 meter from the front, <51 dBA, at 1 meter from rear or sides			
Agency				
Safety	IEC62040-1:2008 version, GS mark; UL1778, c-UL listed			
EMI/EMC/C-Tick EMC	IEC/EN/AS 62040-2 2nd Ed (Cat 2 – Table 6); FCC Part 15 (Class A) CISPR22 Class A (RFI)			
ESD	IEC/EN EN61000-4-2, Level 4, Criteria A			
Radiated Susceptibility	IEC/EN EN61000-4-3, Level 3, Criteria A			
Electrical Fast Transient	IEC/EN EN61000-4-4, Level 4, Criteria A			
Surge Immunity	IEC/EN EN61000-4-5, Level 4, Criteria A; ANSI C62.41 Category B			
Transportation	ISTA Procedure 1E			

Table 7.4 Power-distribution Specifications

MODEL NUMBER:	PD5-CE6HDWRMBS PD5-CE6HDWRMBSU	PD5-CE10HDWRMBS PD5-CE10HDWRMBSU
Amp Rating	50 A	63 A
Input Power Connection	Single-phase (L-N-G) hard-wired	
Output Power Connection	Single-phase (L-N-G) hard-wired	
Includes	Two IEC320 C19 16A/250V Sockets Six C13 10A/250V Sockets	Four IEC320 C19 16A/250V Sockets, Four C13 10A/250V Sockets
Input Branch Circuit Breaker, Supplied by User	60 A	70 A

Table 7.5 External Battery Cabinet Specifications

MODEL NUMBER:	GXT5-EBC192VRT3U	GXT5-EBC384VRT6U
USED WITH UPS MODEL:	5 – 10-KVA MODELS	16 – 20-KVA MODELS
Dimensions, WxDxH, mm (in.)		
Unit (with bezel)	430 x 630 x 130 (16.9 x 24.8 x 5.1)	430 x 630 x 261 (16.9 x 24.8 x 10.3)
Shipping	840 x 670 x 465 (33 x 26.4 x 18.3)	840 x 670 x 595 (33 x 26.4 x 23.4)
Weight, kg (lb)		
Unit	57.6 (127)	112 (246.9)
Shipping	80 (176.4)	136 (299.8)
Battery Parameters		
Type	Valve-regulated, non-spillable, lead acid	
Quantity x Voltage	16 x 12V	32 x 12V
Battery Mfr./Part#	9AH; LEOCH/DJW12-9.0	
Back-up Time	See appropriate table for model size in Battery Run Times on the facing page.	
Environmental		
Operating Temp, °C (°F)	0 to 40 (32 to 104)	
Storage Temp, °C (°F)	-15 to 40 (5 to 104)	
Relative Humidity	0 – 95% non-condensing	
Operating Elevation	Up to 3,000 m (9,842.5 ft.) at 25°C (77°F)	
Agency		
Safety	IEC62040-1:2008version,GS mark; UL1778, c-UL listed	
Transportation	ISTA Procedure 1E	

7.1 Battery Run Times

Table 7.6 Battery Run Time, 20-kVA Models

NO. OF EBCS	EBC AH NO.	TOTAL NO. OF AH	BACKUP TIME (MIN)									
			20-KVA	18KVA	16KVA	14KVA	12KVA	10-KVA	8KVA	6KVA	4KVA	2KVA
UPS	0	9	2.5	3.0	3.5	4.0	5.5	7.0	9.5	14.5	26.0	62.5
UPS+1 EBC	9	18	7.0	8.5	10.0	12.0	15.0	19.5	26.5	39.0	64.0	136.0
UPS+2 EBC	18	27	13.0	15.0	18.0	21.5	27.0	34.5	45.5	64.5	101.0	222.5
UPS+3 EBC	27	36	19.5	23.0	27.0	32.5	40.0	50.0	64.5	89.5	139.5	309.5
UPS+4 EBC	36	45	27.0	31.0	36.5	43.5	53.0	65.0	83.5	114.5	183.5	396.5
UPS+5 EBC	45	54	34.5	40.0	46.5	55.0	65.5	80.5	102.5	140.5	228.0	483.0
UPS+6 EBC	54	63	42.5	48.5	56.5	66.0	78.5	95.5	121.5	170.5	272.5	570.0

Table 7.7 Battery Run Time, 16-kVA Models

NO. OF EBCS	EBC AH NO.	TOTAL NO. OF AH	BACKUP TIME (MIN)									
			16KV A	14.4KV A	12.8KV A	11.2KV A	9.6KV A	8KV A	6.4KV A	4.8KV A	3.2KV A	1.6KV A
UPS	0	9	3.5	4.0	5.0	6.0	7.5	9.5	13.5	20.0	35.0	79.0
UPS+1 EBC	9	18	10.0	11.5	14.0	16.5	20.5	26.5	35.5	51.5	82.0	176.0
UPS+2 EBC	18	27	18.0	21.0	24.5	29.5	36.0	45.5	59.5	82.5	128.5	283.0
UPS+3 EBC	27	36	27.0	31.0	36.5	43.5	52.5	64.5	83.0	114.0	183.0	390.0
UPS+4 EBC	36	45	36.5	42.0	49.0	57.5	68.0	83.5	106.5	147.5	238.0	496.5
UPS+5 EBC	45	54	46.5	53.0	61.0	71.0	84.0	102.5	130.5	184.5	293.0	603.5
UPS+6 EBC	54	63	56.5	63.5	73.0	84.5	100.0	121.5	157.5	221.5	348.0	710.5

Table 7.8 Battery Run Time, 10-kVA Models

NO. OF EBCS	EBC AH NO.	TOTAL NO. OF AH	BACKUP TIME (MIN)									
			10-KVA	9KVA	8KVA	7KVA	6KVA	5KVA	4KVA	3KVA	2KVA	1KVA
UPS	0	9	2.0	2.5	3.5	4.0	5.5	7.0	9.5	14.5	25.0	59.0
UPS+1 EBC	9	18	7.0	8.0	9.5	12.0	14.5	19.0	26.0	38.5	62.5	129.0
UPS+2 EBC	18	27	13.0	15.0	17.5	21.0	26.0	33.5	45.0	63.5	99.0	211.0
UPS+3 EBC	27	36	19.5	22.5	26.5	31.5	39.0	49.0	64.0	88.0	136.0	294.0
UPS+4 EBC	36	45	26.5	30.5	36.0	42.5	51.5	64.0	82.5	113.0	179.5	377.0
UPS+5 EBC	45	54	34.5	39.5	45.5	54.0	64.5	79.0	101.0	138.5	222.5	460.0
UPS+6 EBC	54	63	42.0	48.0	55.5	64.5	77.0	94.0	120.0	168.0	266.0	543.0

Table 7.9 Battery Run Time, 8-kVA Models

NO. OF EBCS	EBC AH NO.	TOTAL NO. OF AH	BACKUP TIME (MIN)									
			8KV A	7.2KV A	6.4KV A	5.6KV A	4.8KV A	4KV A	3.2KV A	2.4KV A	1.6KV A	0.8KV A
UPS	0	9	3.5	4.0	4.5	6.0	7.5	9.5	13.0	19.5	33.5	75.0
UPS+1 EBC	9	18	9.5	11.5	13.5	16.0	20.0	26.0	35.0	50.5	79.0	166.0
UPS+2 EBC	18	27	17.5	20.5	24.0	29.0	35.5	45.0	59.0	81.5	124.5	267.5
UPS+3 EBC	27	36	26.5	30.5	35.5	42.5	51.5	64.0	82.0	112.5	176.0	369.0
UPS+4 EBC	36	45	36.0	41.0	48.0	56.0	67.0	82.5	105.5	145.0	229.5	471.0
UPS+5 EBC	45	54	45.5	52.0	59.5	69.5	82.5	101.0	128.5	181.5	283.0	572.5
UPS+6 EBC	54	63	55.5	62.5	71.5	83.0	98.5	120.0	155.0	218.0	336.5	674.5

Table 7.10 Battery Run Time, 6-kVA Models

NO. OF EBCS	EBC AH NO.	TOTAL NO. OF AH	BACKUP TIME (MIN)									
			6KV A	5.4KV A	4.8KV A	4.2KV A	3.6KV A	3KV A	2.4KV A	1.8KV A	1.2KV A	0.6KV A
UPS	0	9	5.5	6.0	7.5	9.0	11.0	14.5	19.5	29.0	48.0	100.0
UPS+1 EBC	9	18	14.5	17.0	20.0	24.0	30.0	38.5	50.5	70.0	107.0	226.0
UPS+2 EBC	18	27	26.0	30.5	35.5	42.0	51.0	63.5	81.5	110.0	172.0	357.5
UPS+3 EBC	27	36	39.0	44.5	51.5	60.5	72.0	88.0	112.5	154.0	242.0	489.0
UPS+4 EBC	36	45	51.5	58.5	67.0	78.0	92.5	113.0	145.0	201.5	312.0	621.0
UPS+5 EBC	45	54	64.5	72.5	82.5	96.0	113.5	138.5	181.5	249.5	382.0	752.5
UPS+6 EBC	54	63	77.0	86.5	98.5	113.5	134.0	168.0	218.0	297.5	452.0	884.5

Table 7.11 Battery Run Time, 5-kVA Models

NO. OF EBCS	EBC AH NO.	TOTAL NO. OF AH	BACKUP TIME (MIN)									
			5KVA	4.5KVA	4KVA	3.5KVA	3KVA	2.5KVA	2KVA	1.5KVA	1KVA	0.5KVA
UPS	0	9	7.0	8.0	9.5	11.5	14.5	18.5	25.0	36.5	59.0	120.0
UPS+1 EBC	9	18	19.0	22.0	26.0	31.0	38.5	48.0	62.5	85.0	129.0	272.5
UPS+2 EBC	18	27	33.5	38.5	45.0	53.0	63.5	78.0	99.0	133.0	211.0	427.5
UPS+3 EBC	27	36	49.0	55.5	64.0	74.0	88.0	107.5	136.0	189.5	294.0	582.5
UPS+4 EBC	36	45	64.0	72.0	82.5	95.5	113.0	138.0	179.5	246.0	377.0	737.5
UPS+5 EBC	45	54	79.0	89.0	101.0	117.0	138.5	173.0	222.5	303.0	460.0	892.5
UPS+6 EBC	54	63	94.0	105.5	120.0	139.0	168.0	208.0	266.0	359.5	543.0	1047.5

This page intentionally left blank

APPENDICES

Appendix A: Technical Support

Our Technical Support staff is ready to assist you with any installation or operating issues you may encounter with your Liebert® product. Please call or e-mail us:

In Europe, Middle East, and Asia:

EMEA Multi-Language Technical support:

e: eoc@vertivco.com

p: Toll free 0080011554499

p: Toll +39 02 98250222

In the United States:

Technical support:

e: liebert.upstech@vertivco.com

p: 1-800-222-5877 menu option 1

Monitoring support:

e: liebert.monitoring@vertivco.com

p: 1-800-222-5877 menu option 2

Warranty support:

e: microups.warranty@vertivco.com

p: 1-800-222-5877 menu option 3

This page intentionally left blank





VertivCo.com | Vertiv Headquarters, 1050 Dearborn Drive, Columbus, OH, 43085, USA

© 2018 Vertiv Co. All rights reserved. Vertiv and the Vertiv logo are trademarks or registered trademarks of Vertiv Co. All other names and logos referred to are trade names, trademarks or registered trademarks of their respective owners. While every precaution has been taken to ensure accuracy and completeness herein, Vertiv Co. assumes no responsibility, and disclaims all liability, for damages resulting from use of this information or for any errors or omissions. Specifications are subject to change without notice.

590-1927-501B