



## FCC Part 15 Subpart B Test Report

### FCC PART 15 Subpart B Class B

Report Reference No..... : WUX202108114101F

Compiled by  
 ( position+printed name+signature).. : File administrators Bailey Luo

Name of the organization performing the tests  
 ( position+printed name+signature).. : Test Engineer Alison Liu

Approved by  
 ( position+printed name+signature).. : Manager Tony Bi

Date of issue..... : August 17, 2021

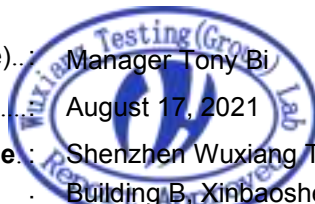

Representative Laboratory Name : Shenzhen Wuxiang Testing (Group) Co., Ltd.  
 Address..... : Building B, Xinbaosheng, No.233, Xixiang Street, Bao'an District, Shenzhen, China

Applicant's name..... : SHENZHEN BDLX ELECTRONIC CO., LTD.  
 Address..... : 2203 Tower B,Building 1,Ronghu central city,Pinghu Town ,Longgang District,Shenzhen ,China

Importer : /

Address : /

#### Test specification:

Standard..... : FCC PART 15 Subpart B Class B  
 TRF Originator..... : Shenzhen Wuxiang Testing (Group) Co., Ltd.  
 Master TRF..... : Dated 2014-08

Shenzhen Wuxiang Testing (Group) Co., Ltd.This publication may be reproduced in whole or in part for non-commercial purposes as long as the Shenzhen Wuxiang Testing (Group) Co., Ltd. is acknowledged as copyright owner and source of the material. Shenzhen Wuxiang Testing (Group) Co., Ltd. takes no responsibility for and will not assume liability for damages resulting from the reader's interpretation of the reproduced material due to its placement and context.

Test item description..... : Ring Light  
 Trade Mark..... : /  
 Model/Type reference..... : X-409-6A  
 Listed Models ..... : X-409-6,X-409-9A,RGB-6A,RGB-6B,X-409-7B,X-409-7B-1,RGB-10B-1,RGB-10B-2,X-409-10B,X-409-10B-1,X-409-6B,X-409-6B-1,X-409-10F,X-409-10F-1,X-409-10C,X-409-6C,X-409-10G,X-6B,X-6C,X-10A-1,X-10A-2,X-10B-1,X-10B-2,X-409-6A,X-409-7A,X-409-10H,X-409-D,X-12A,X-12B,X-409-10,X-409-E,X-409-8,X-409-1,X-409-G,X-409-G-1,X-409-G-2,X-409-F,X-409-F-1,X-409-F-2,X-409-H,X-409-H-1,X-409-H-2,X-409-K,X-409-K-1,X-409-K-2,X-409-K-3,X-409-K-4,X-409-K-5,X-409-K-6,X-409-K-7,X-409-K-8,X-409-K-9,X-409-K-10  
 Power Supply..... : Input: DC 5V  
 Result..... : **Positive**

# FCC Test Report

<b>Test Report No. :</b> WUX202108114101F	August 17, 2021 Date of issue
---	----------------------------------

Equipment under Test : Ring Light

Model /Type : X-409-6A

Listed Models : X-409-6,X-409-9A,RGB-6A,RGB-6B,X-409-7B,X-409-7B-1,RGB-10B-1,RGB-10B-2,X-409-10B,X-409-10B-1,X-409-6B,X-409-6B-1,X-409-10F,X-409-10F-1,X-409-10C,X-409-6C,X-409-10G,X-6B,X-6C,X-10A-1,X-10A-2,X-10B-1,X-10B-2,X-409-6A,X-409-7A,X-409-10H,X-409-D,X-12A,X-12B,X-409-10,X-409-E,X-409-8,X-409-1,X-409-G,X-409-G-1,X-409-G-2,X-409-F,X-409-F-1,X-409-F-2,X-409-H,X-409-H-1,X-409-H-2,X-409-K,X-409-K-1,X-409-K-2,X-409-K-3,X-409-K-4,X-409-K-5,X-409-K-6,X-409-K-7,X-409-K-8,X-409-K-9,X-409-K-10

**Applicant** : SHENZHEN BDLX ELECTRONIC CO., LTD.

Address : 2203 Tower B,Building 1,Ronghu central city,Pinghu Town ,Longgang District,Shenzhen ,China

**Manufacturer** : SHENZHEN XTW ELECTRONIC CO., LTD.

Address : 201-2, 2/F ,Building A,No.28, Tongfu Road,Renwu village Pinghu Town Longgang District, Shenzhen , P.R.China

Importer : /

Address : /

<b>Test Result</b> according to the standards on page 4:	<b>Positive</b>
--	-----------------

The test report merely corresponds to the test sample.  
It is not permitted to copy extracts of these test result without the written permission of the test laboratory.

# Content

- 1. TEST STANDARDS .....4**
  
- 2. SUMMARY ..... 5**
  - 2.1. General Remarks.....5
  - 2.2. Equipment Under Test.....5
  - 2.3. Short description of the Equipment under Test (EUT)..... 5
  - 2.4. EUT operation mode..... 5
  - 2.5. EUT configuration.....5
  - 2.6. Related Submittal(s) / Grant (s).....6
  - 2.7. Modifications.....6
  - 2.8. Test Result Summary.....6
  
- 3. TEST ENVIRONMENT .....7**
  - 3.1. Address of the test laboratory.....7
  - 3.2. Test Facility..... 7
  - 3.3. Environmental conditions..... 7
  - 3.4. Statement of the measurement uncertainty..... 7
  - 3.5. Equipments Used during the Test.....8
  
- 4. TEST CONDITIONS AND RESULTS .....9**
  - 4.1. Radiated Emission Test..... 9
  - 4.2. Conducted Emissions Test..... 13
  
- 5. PHOTOS OF THE EUT ..... 14**

## **1. TEST STANDARDS**

The tests were performed according to following standards:

[FCC Rules Part 15 Subpart B - Unintentional Radiators](#)

[ANSI C63.4-2003](#)

## 2. SUMMARY

### 2.1. General Remarks

Date of receipt of test sample : August 11, 2021

Testing commenced on : August 12, 2021

Testing concluded on : August 17, 2021

### 2.2. Equipment Under Test

#### Power supply system utilised

Power supply voltage :  100V / 60 Hz  240V / 60Hz  
 12 V DC  24 V DC  
 Other (specified in blank below)

DC 5V

---

### 2.3. Short description of the Equipment under Test (EUT)

Ring Light Insert: Usage of Machine, Place it will be used, Functions For more details, refer to the user's manual of the EUT.

Serial number: X-409-6A

### 2.4. EUT operation mode

The EUT has been tested under typical operating condition.

### 2.5. EUT configuration

The following peripheral devices and interface cables were connected during the measurement:

- - supplied by the manufacturer
- - supplied by the lab

## 2.6. Related Submittal(s) / Grant (s)

This test report is intended for X-409-6A filing to comply with the FCC Part 15, Subpart B Rules.

## 2.7. Modifications

No modifications were implemented to meet testing criteria.

## 2.8. Test Result Summary

Test Item	Test Requirement	Standard Paragraph	Result
Radiated Emission	FCC PART 15 Subpart B Class B: 2014	Section 15.109	PASS
Conducted Emission	FCC PART 15 Subpart B Class B: 2014	Section 15.107	N/A

### 3. TEST ENVIRONMENT

#### 3.1. Address of the test laboratory

CCIC Southern Electronic Product Testing (Shenzhen) Co., Ltd  
Electronic detection of building, Shahe West Road, Xili Town, Nanshan, Shenzhen, China.

There is one 3m semi-anechoic chamber and two line conducted labs for final test.  
The Test Sites meet the requirements in documents ANSI C63.4 and CISPR 22/EN 55022 requirements.

#### 3.2. Test Facility

The test facility is recognized, certified, or accredited by the following organizations:

##### IC Registration No.: 7631A

The 3m alternate test site of CCIC Southern Electronic Product Testing (Shenzhen) Co., Ltd EMC Laboratory has been registered by Certification and Engineer Bureau of Industry Canada for the performance of with Registration NO.: 7631A on March, 2011.

##### FCC-Registration No.: 338263

CCIC Southern Electronic Product Testing (Shenzhen) Co., Ltd EMC Laboratory has been registered and fully described in a report filed with the (FCC) Federal Communications Commission. The acceptance letter from the FCC is maintained in our files. Registration 338263, March 24, 2008.

#### 3.3. Environmental conditions

During the measurement the environmental conditions were within the listed ranges:

Temperature:	<u>15-35 ° C</u>
Humidity:	<u>30-60 %</u>
Atmospheric pressure:	<u>950-1050mbar</u>

#### 3.4. Statement of the measurement uncertainty

The data and results referenced in this document are true and accurate. The reader is cautioned that there may be errors within the calibration limits of the equipment and facilities. The measurement uncertainty was calculated for all measurements listed in this test report acc. to CISPR 16 - 4 „Specification for radio disturbance and immunity measuring apparatus and methods – Part 4: Uncertainty in EMC Measurements“ and is documented in the CCIC Southern Electronic Product Testing (Shenzhen) Co., Ltd quality system acc. to DIN EN ISO/IEC 17025. Furthermore, component and process variability of devices similar to that tested may result in additional deviation. The manufacturer has the sole responsibility of continued compliance of the device.

Hereafter the best measurement capability for CCIC laboratory is reported:

Test	Range	Measurement Uncertainty	Notes
Radiated Emission	30~1000MHz	4.10dB	(1)
Radiated Emission	1~12.75GHz	4.32dB	(1)
Conducted Disturbance	0.15~30MHz	3.22dB	(1)

(1) This uncertainty represents an expanded uncertainty expressed at approximately the 95% confidence level using a coverage factor of k=2.

### 3.5. Equipments Used during the Test

Radiated Emission					
Item	Test Equipment	Manufacturer	Model No.	Serial No.	Last Cal.
1	ULTRA-BROADBAND ANTENNA	Sunol Sciences Corp.	JB1 Antenna	A061713	2021/05
2	EMI TEST RECEIVER	ROHDE & SCHWARZ	ESPI	1164.6407.07	2021/05
3	RF TEST PANEL	ROHDE & SCHWARZ	TS / RSP	335015/ 0017	2021/05
4	Controller	EM Electronics	Controller EM 1000	N/A	2021/05
5	EMI TEST SOFTWARE	ROHDE & SCHWARZ	ESK1	N/A	2021/05

Conducted Emission					
Item	Test Equipment	Manufacturer	Model No.	Serial No.	Last Cal.
1	EMI Test Receiver	ROHDE & SCHWARZ	ESCI	1166.5950.03	2021/05
2	LISN	ROHDE & SCHWARZ	ENV216	101034	2021/05
4	EMI Test Software	ROHDE & SCHWARZ	ESK1	N/A	2021/05



## 4. TEST CONDITIONS AND RESULTS

### 4.1. Radiated Emission Test

#### TEST CONFIGURATION

(A) Radiated Emission Test Set-Up, Frequency Below 30MHz

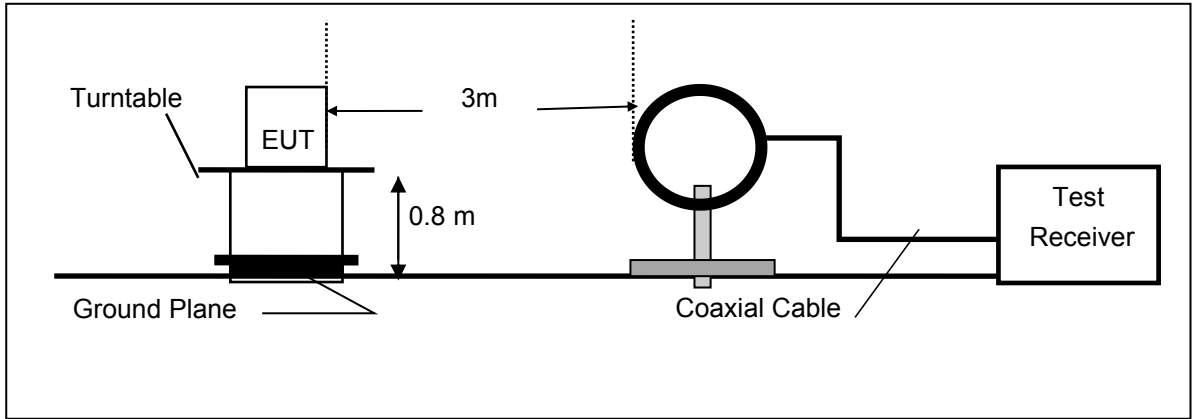

(B) Radiated Emission Test Set-Up, Frequency below 1000MHz

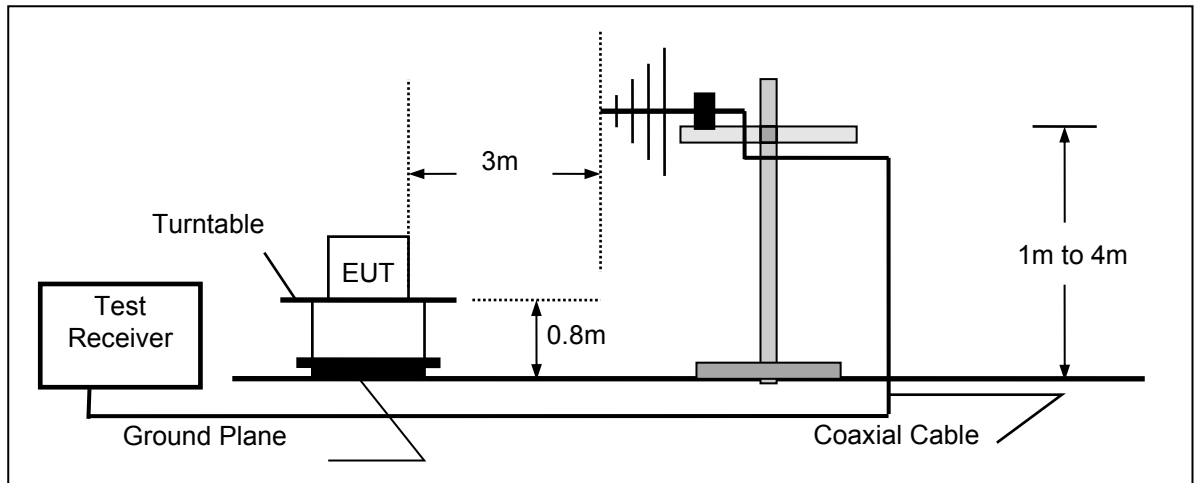

(C) Radiated Emission Test Set-Up, Frequency above 1000MHz

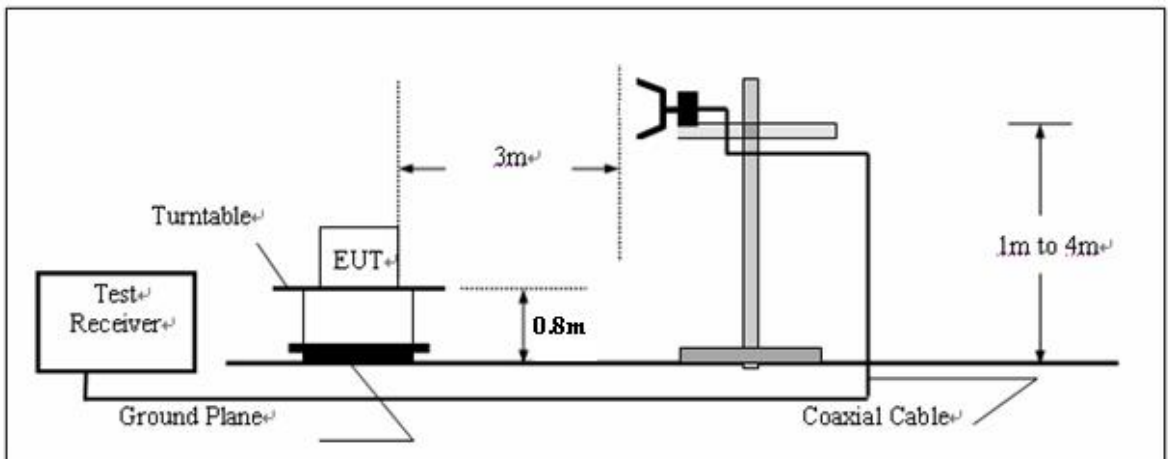

**Field Strength Calculation**

The field strength is calculated by adding the Antenna Factor and Cable Factor and subtracting the Amplifier Gain and Duty Cycle Correction Factor(if any) from the measured reading. The basic equation with a sample calculation is as follows:

$$FS = RA + AF + CL - AG$$

Where FS = Field Strength	CL = Cable Attenuation Factor (Cable Loss)
RA = Reading Amplitude	AG = Amplifier Gain
AF = Antenna Factor	

**RADIATION LIMIT**

For unintentional device, according to § 15.109(a), except for Class A digital devices, the field strength of radiated emissions from unintentional radiators at a distance of 3 meters shall not exceed the following values:

Frequency (MHz)	Distance (Meters)	Radiated (dBµV/m)	Radiated (µV/m)
30-88	3	40.0	100
88-216	3	43.5	150
216-960	3	46.0	200
Above 960	3	54.0	500

For intentional device, according to § 15.209(a), the general requirement of field strength of radiated emissions from intentional radiators at a distance of 3 meters shall not exceed the above table.

**Test Procedure**

1. The EUT is placed on a turntable, which is 0.8m above ground plane.
2. The turntable shall be rotated for 360 degrees to determine the position of maximum emission level.
3. EUT is set 3m away from the receiving antenna, which is varied from 1m to 4m to find out the highest emissions.
4. Maximum procedure was performed on the six highest emissions to ensure EUT compliance.
5. And also, each emission was to be maximized by changing the polarization of receiving antenna both horizontal and vertical.
6. Repeat above procedures until the measurements for all frequencies are complete.

**Radiation Test Results**

**SCAN TABLE: "test Field(30M-1G)QP"**

Short Description: Field Strength(30M-1G)  
 Start Stop Step Detector Meas. IF Transducer  
 Frequency Frequency Width Time Bandw.  
 30.0 MHz 1.0 GHz 60.0 kHz QuasiPeak 1.0 s 120 kHz HL562 09

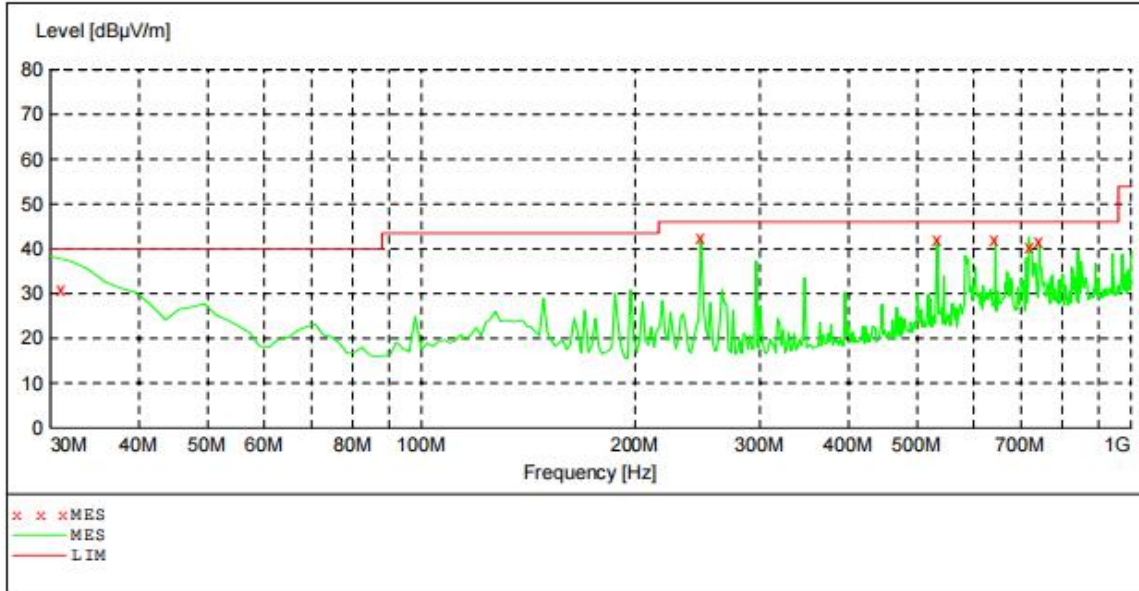

**MEASUREMENT RESULT :**

Frequency MHz	Level dBµV/m	Transd dB	Limit dBµV/m	Margin dB	Det.	Height cm	Azimuth deg	Polarization
31.080000	30.80	-5.3	40.0	9.2	QP	100.0	89.00	VERTICAL
247.710000	42.50	-12.5	46.0	3.5	QP	100.0	137.00	VERTICAL
533.460000	41.90	-5.8	46.0	4.1	QP	100.0	352.00	VERTICAL
644.260000	42.00	-3.2	46.0	4.0	QP	100.0	130.00	VERTICAL
720.060000	40.60	-2.9	46.0	5.4	QP	100.0	184.00	VERTICAL
743.400000	41.70	-2.2	46.0	4.3	QP	100.0	137.00	VERTICAL

**SCAN TABLE: "test Field(30M-1G)QP"**

Short Description:		Field Strength(30M-1G)				
Start	Stop	Step	Detector	Meas. Time	IF Bandw.	Transducer
Frequency	Frequency	Width				
30.0 MHz	1.0 GHz	60.0 kHz	QuasiPeak	1.0 s	120 kHz	HL562 09

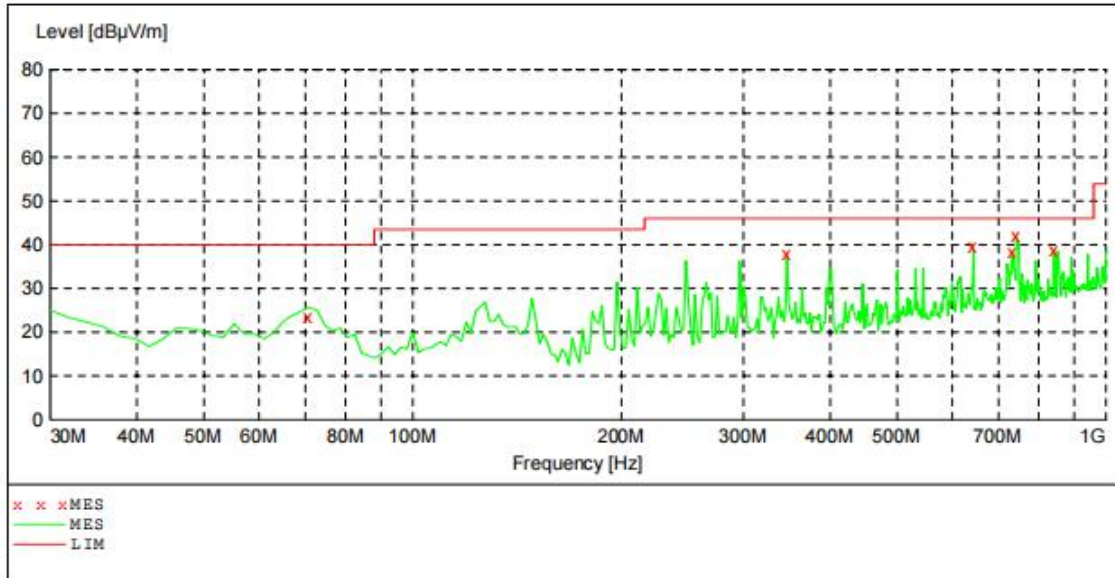

**MEASUREMENT RESULT:**

Frequency MHz	Level dBµV/m	Transd dB	Limit dBµV/m	Margin dB	Det.	Height cm	Azimuth deg	Polarization
70.820000	23.50	-4.8	40.0	16.5	QP	100.0	48.00	HORIZONTAL
346.850000	37.90	-9.8	46.0	8.1	QP	100.0	167.00	HORIZONTAL
644.260000	39.40	-3.2	46.0	6.6	QP	100.0	53.00	HORIZONTAL
733.680000	38.20	-2.6	46.0	7.8	QP	100.0	227.00	HORIZONTAL
743.400000	42.00	-2.2	46.0	4.0	QP	100.0	207.00	HORIZONTAL
842.540000	38.70	-0.7	46.0	7.3	QP	100.0	187.00	HORIZONTAL

## 4.2. Conducted Emissions Test

### TEST CONFIGURATION

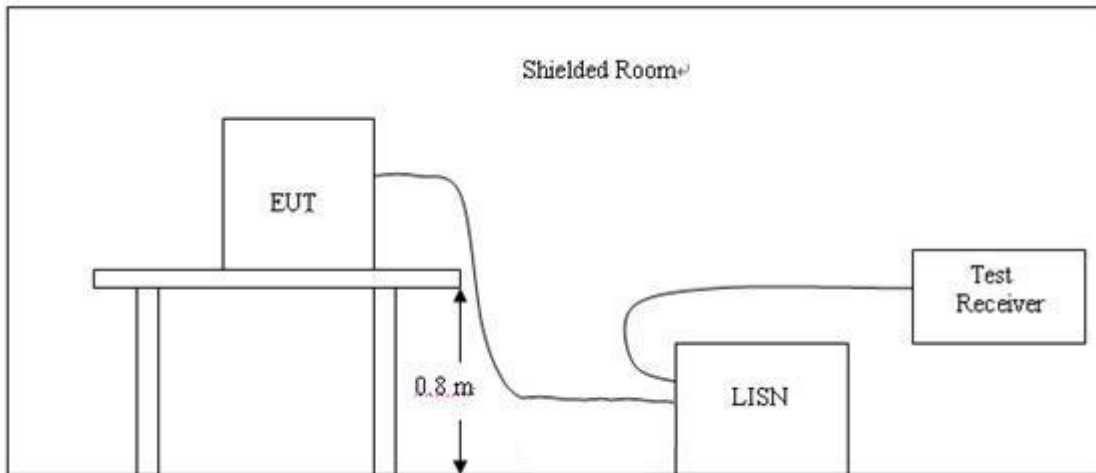

### TEST PROCEDURE

- 1 The equipment was set up as per the test configuration to simulate typical actual usage per the user's manual. The EUT is a tabletop system, a wooden table with a height of 0.8 meters is used and is placed on the ground plane as per ANSI C63.4.
- 2 Support equipment, if needed, was placed as per ANSI C63.4.
- 3 All I/O cables were positioned to simulate typical actual usage as per ANSI C63.4.
- 4 The EUT received power through a Line Impedance Stabilization Network (LISN) which supplied power source and was grounded to the ground plane.
- 5 All support equipments received AC power from a second LISN, if any.
- 6 The EUT test program was started. Emissions were measured on each current carrying line of the EUT using a spectrum Analyzer / Receiver connected to the LISN powering the EUT. The LISN has two monitoring points: Line 1 (Hot Side) and Line 2 (Neutral Side). Two scans were taken: one with Line 1 connected to Analyzer / Receiver and Line 2 connected to a 50 ohm load; the second scan had Line 1 connected to a 50 ohm load and Line 2 connected to the Analyzer / Receiver.
- 7 Analyzer / Receiver scanned from 150 KHz to 30MHz for emissions in each of the test modes.
- 8 During the above scans, the emissions were maximized by cable manipulation.

### Conducted Power Line Emission Limit

For unintentional device, according to § 15.107(a) Line Conducted Emission Limits is as following :

Frequency (MHz)	Maximum RF Line Voltage (dBµV)			
	CLASS A		CLASS B	
	Q.P.	Ave.	Q.P.	Ave.
0.15 - 0.50	79	66	66-56*	56-46*
0.50 - 5.00	73	60	56	46
5.00 - 30.0	73	60	60	50

\* Decreasing linearly with the logarithm of the frequency

For intentional device, according to §15.207(a) Line Conducted Emission Limit is same as above table.

### TEST RESULTS

The test is not applicable

## 5. Photos of the EUT



.....End of Report.....