

15 min	x1	x1	x1

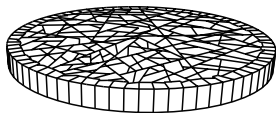

**A** x1

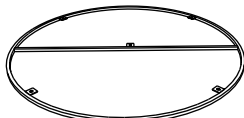

**B** x1



**C** x1



**D** x4

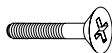

**E** x13

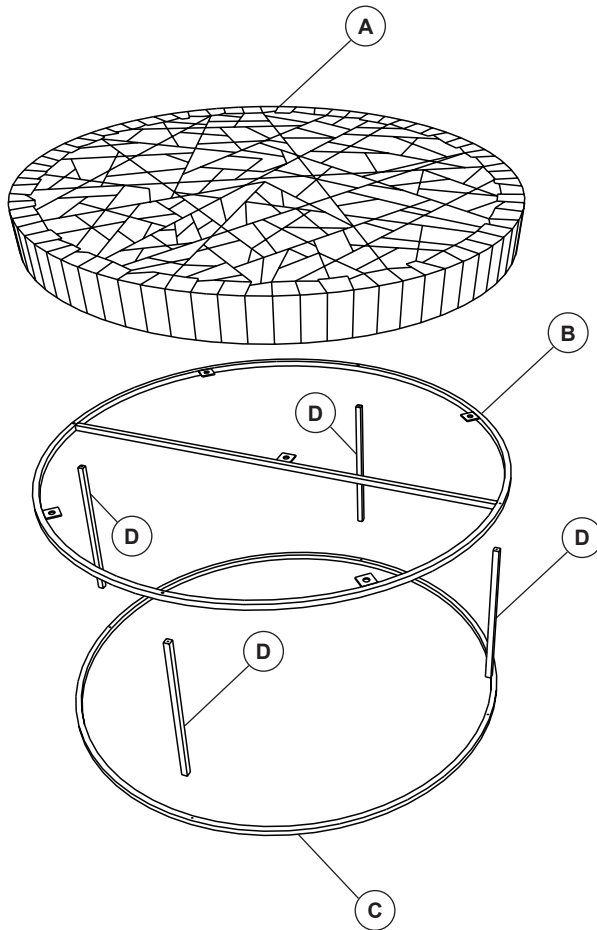

1

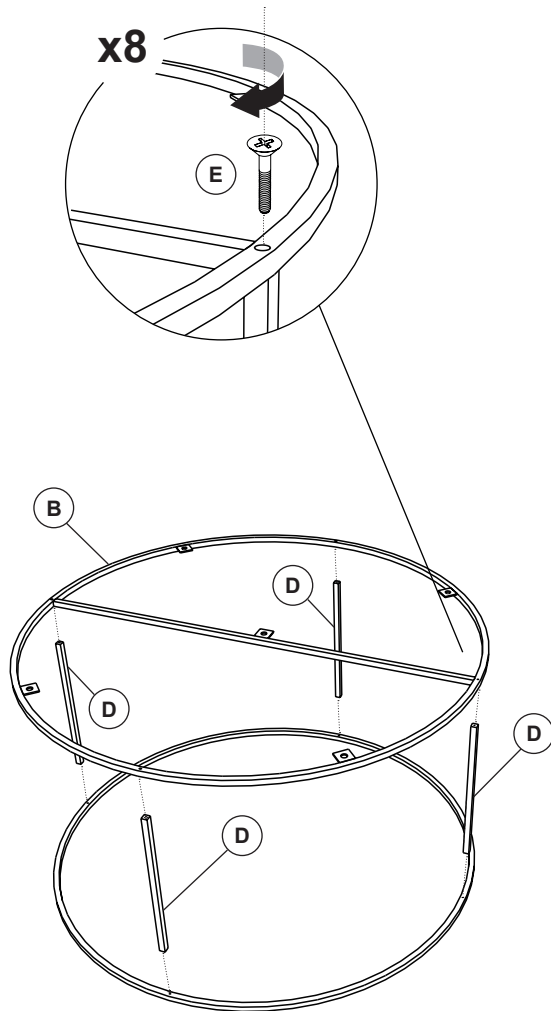

2

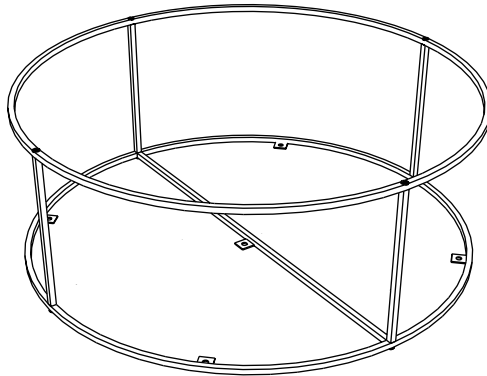
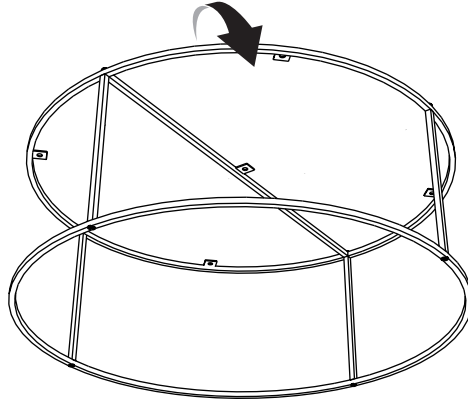

3

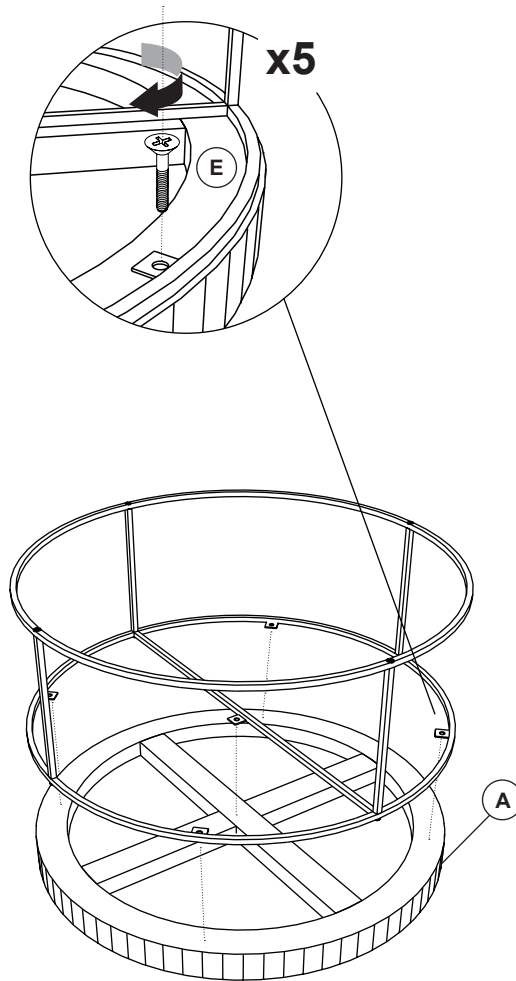

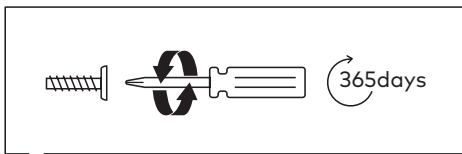
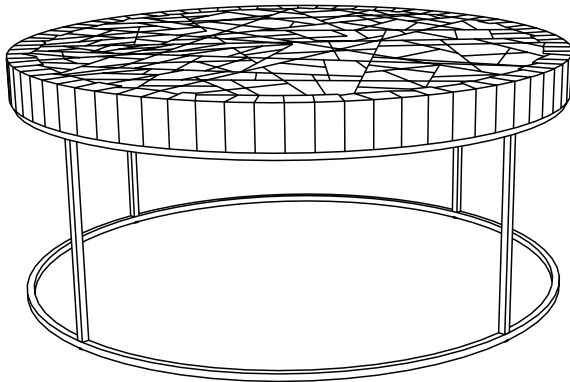











**THAT'S ALL FOLKS!**

Share your style!

**#KaveHome**

