

Dear Kickbike - owner,

Thank you for having chosen the Kickbike - scooter! It is our own original Finnish design, invention and a brand name since 1994. We still have a passion to develop better products for scooter lovers so the work goes on.

Please read this manual so that you can enjoy your Kickbike without problems. In the manual there are step by step instructions of how to first assemble your Kickbike and also how to adjust it to fit your needs. This manual covers all models. If there are differences in some components it is clearly shown which model we talk about.

If you have anything to ask please contact your dealer or us directly. It is our priority that you are happy with the Kickbike - scooter!

Happy kicking!

Hannu Vierikko
"Mr Kickbike"

Contents

➤ Installation and adjustment:	
➤ handlebars	2
➤ mudguards	3
➤ wheels	4
➤ tires	4
➤ brakes	5
➤ footboard/frame	6
➤ kickstand	7
➤ basket	7
➤ suspension fork	7
➤ fold & unfold CliX	8
➤ Others:	
➤ maintenance	9
➤ warnings	9
➤ warranty	9
➤ tips	9

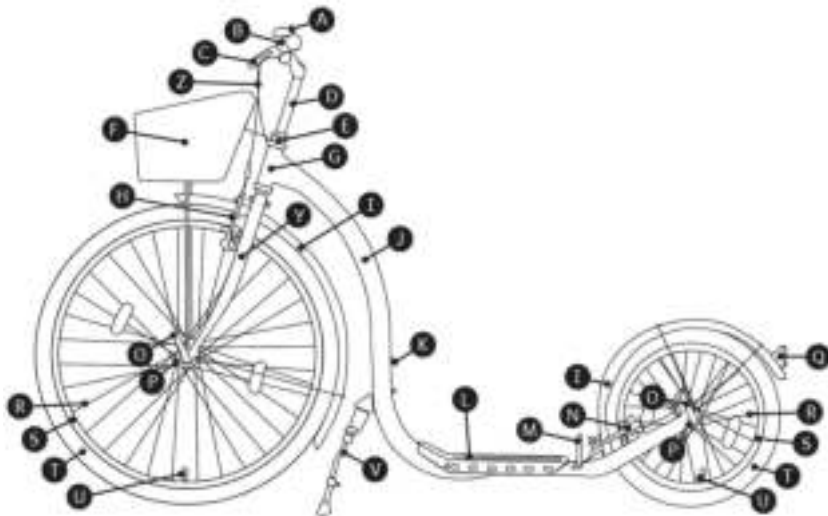

City G4 (Quite similar to Freeride, Sport G4, Cruise MAX 20, Race MAX 20/28)

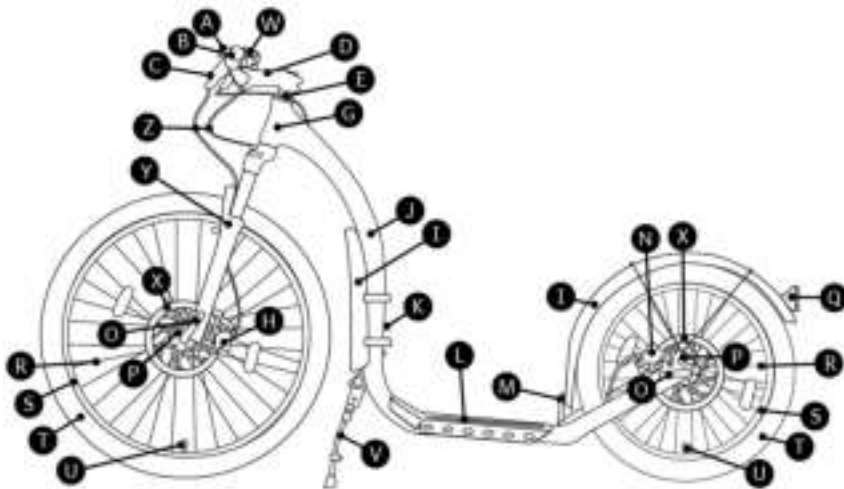

Cross MAX 20D/20HD (Quite similar to Cross MAX 20V, Cross 29er, FAT MAX)

The frame number is written on the front part of the head tube, just below the Kickbike figure. We recommended you write it here.

My Kickbike frame number is: _____

Part list

- A. Bell
- B. Handlebars
- C. Brake lever
- D. Handlebar stem
- E. Headset bearing
- F. Basket (only in City G4)
- G. Head tube
- H. Front brake
- I. Mudguard
- J. Frame
- K. Drinking bottle fixing screws
- L. Footboard
- M. Heel stopper
- N. Rear brake
- O. Quick release skewer
- P. Hub
- Q. Rear reflector
- R. Spoke
- S. Rim
- T. Tyre
- U. Valve
- V. Kickstand
- W. Remote lockout
- X. Brake disc
- Y. (Suspension) fork
- Z. Brake cables

Handlebar installation

Freeride (Fig. 1), City G4 (Fig. 2)

1. Insert stem into head tube.
2. Tighten stem bolt with a 6mm allen key. (Freeride Fig. 1.2, City Fig. 2)
3. Tighten clamp bolts. (1.2) If you want you can first adjust the angle of the handlebars (Freeride)



Notice that the "min insertion" mark has to be inside the head tube!

Sport G4, Cross-models, FAT MAX, Cruise MAX 20, Race-models, (Fig. 3)

1. Attach handlebar to stem. (3.1)
2. Tighten bolts
3. Loosen cap bolt. Take care that the front fork doesn't fall!
4. Lift cap bolt and cap (3.2 - A)
5. Place stem, stem bolt and cap (A) to steerer tube of front fork (3.3)
6. Tighten cap bolt. Finger tightness is enough.
7. Make sure that the stem is straight relative to the front wheel. Tighten clamp bolts. (3.3)

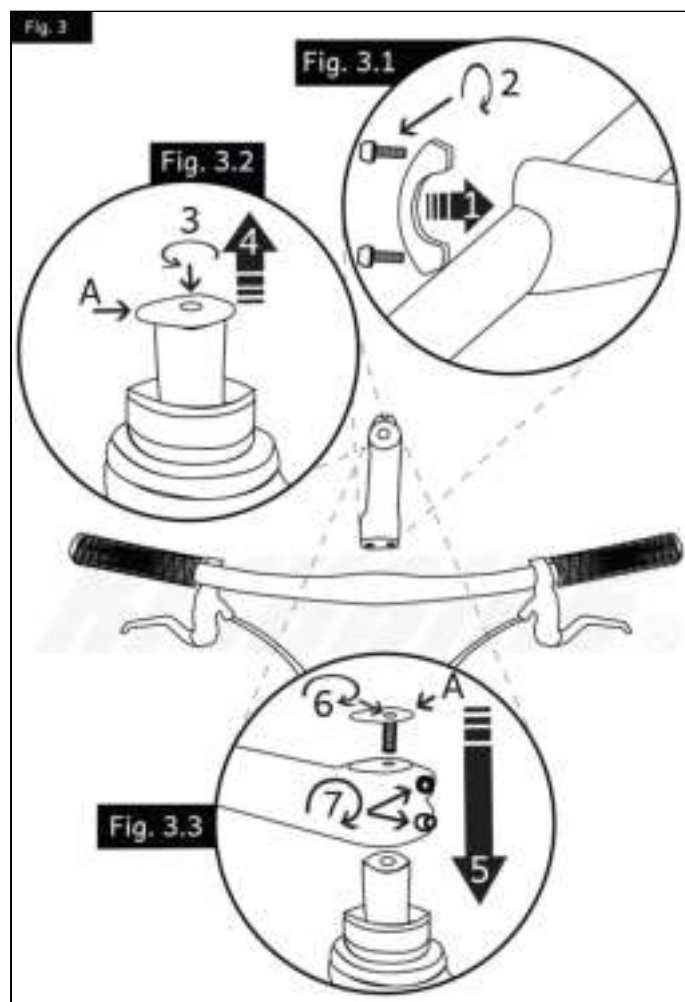
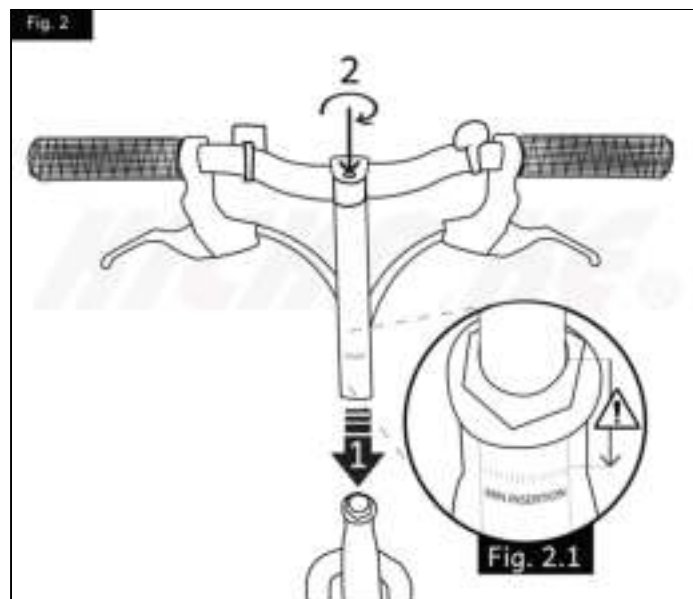
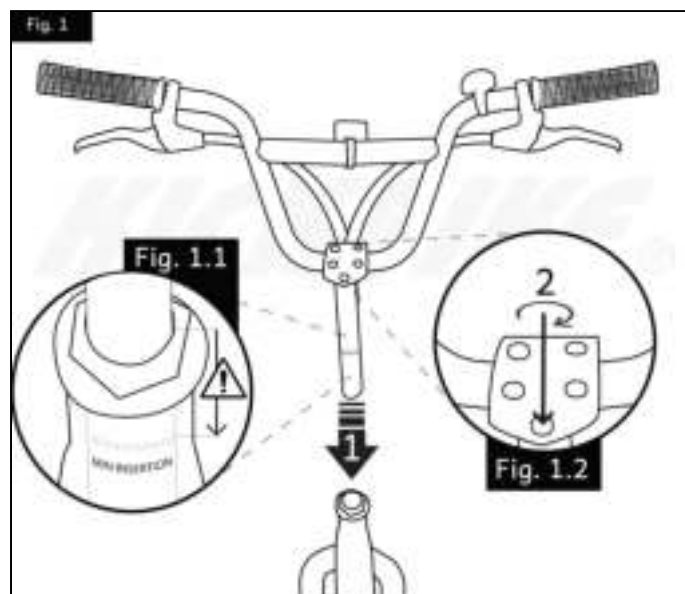

Installation of the mudguards

Front mudguard

City G4, Sport G4, FAT MAX (Fig. 4)

1. Open the mudguard attachment nut in the fork and place the mudguard
2. Tighten the nut (Use 5mm allen key to prevent bolt from turning). (4.1)
3. Attach the mudguard brackets on both sides of the fork with screws provided.

CliX, Cross, Freeride, Race:

A plastic frame mudguard is assembled.

Check that the fixing straps are tight. (Fig. 5, A)

Rear mudguard

CliX, City G4, Sport G4, Freeride (Fig. 6, position B, D)

Cross (Fig. 6, position B, C)

Race MAX 20 (Fig. 6, position A, D)

Cruise MAX, FAT MAX (Fig. 6, position A, C)

1. Attach the front part of the mudguard to the rear arch of the footboard. (Fig. 6.1)
2. Attach the mudguard brackets to both sides of the rear fork with screws provided. (Fig. 6)

Race MAX 28 no mudguards as standard (optional, Fig. 6, position C, A).

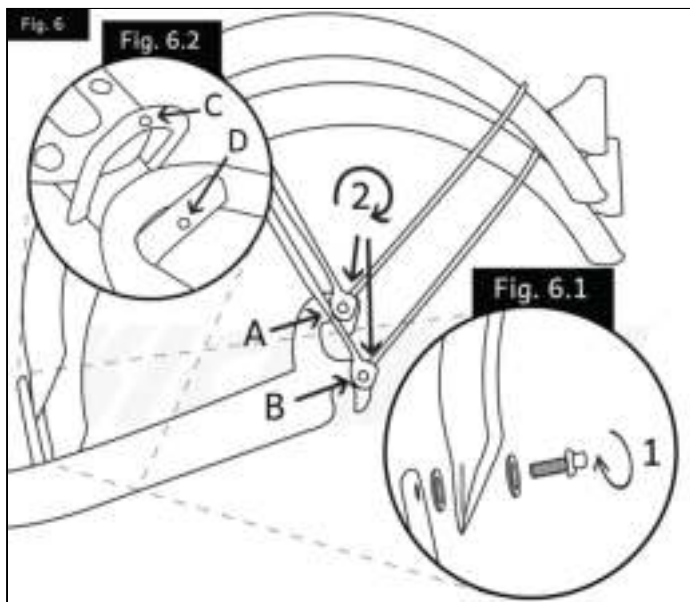
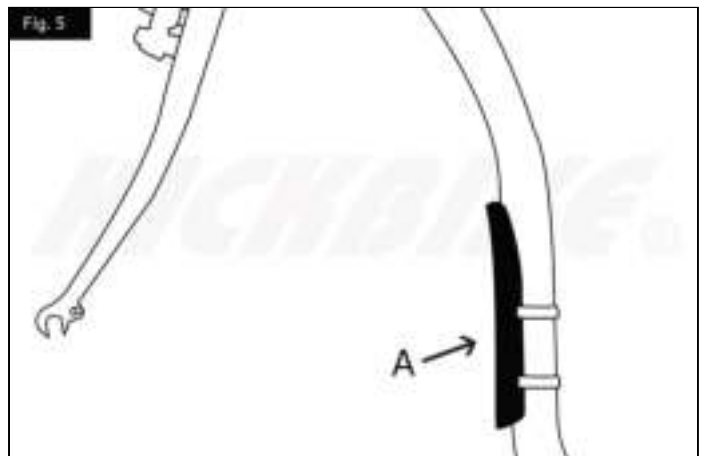
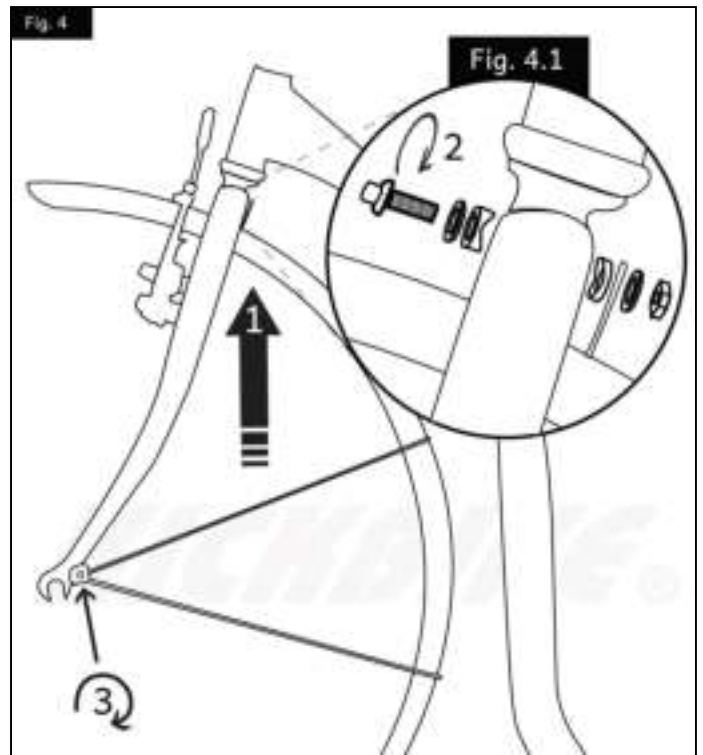

Installation of the wheels

CliX, Freeride, City G4, Sport G4, Cruise MAX, Cross MAX 20V, Race MAX 20 (Fig. 7 and 8)

Race MAX 28 (Fig. 8, skip steps 1,2 by opening switch Fig. 11 A)

Cross MAX 20D, Cross MAX 20HD, Cross 29er (Fig. 8, skip steps 1,2 by taking away plastic disc cover Fig. 7.2)

note: Quick release skewers are of different lengths in all models except CliX, FAT MAX and Race MAX 28. The longer skewer is for the front wheel.

note: Wheels are different sizes in all models except CliX and Race MAX 28. Bigger wheel is the front wheel.

1. To open the brake, squeeze the brake arms... (Fig. 7)
2. ...and slide the brake cable out of it's slot. (Fig. 7.1)
3. Place the wheel
 - a. Front wheel (Fig. 8.1)
 - b. Rear wheel (Fig. 8.2) **CliX, City G4, Sport G4, Cross-models, Freeride, FAT MAX** (position B)
Race-models, Cruise MAX (position A)
4. Insert the quick release skewer. Note the position and direction of the springs. (Fig. 8)
5. Tighten the nut of the quick release. (Fig. 8)
6. Close the lever of the quick release. (Fig. 8) At correct tightness you need brisk force but never tools to close it. Align the lever so that it's not likely to catch your shoelaces.
7. Squeeze both brake arms... (Fig. 8)
8. ... to place brake cable back to it's slot. (Fig. 8.3)

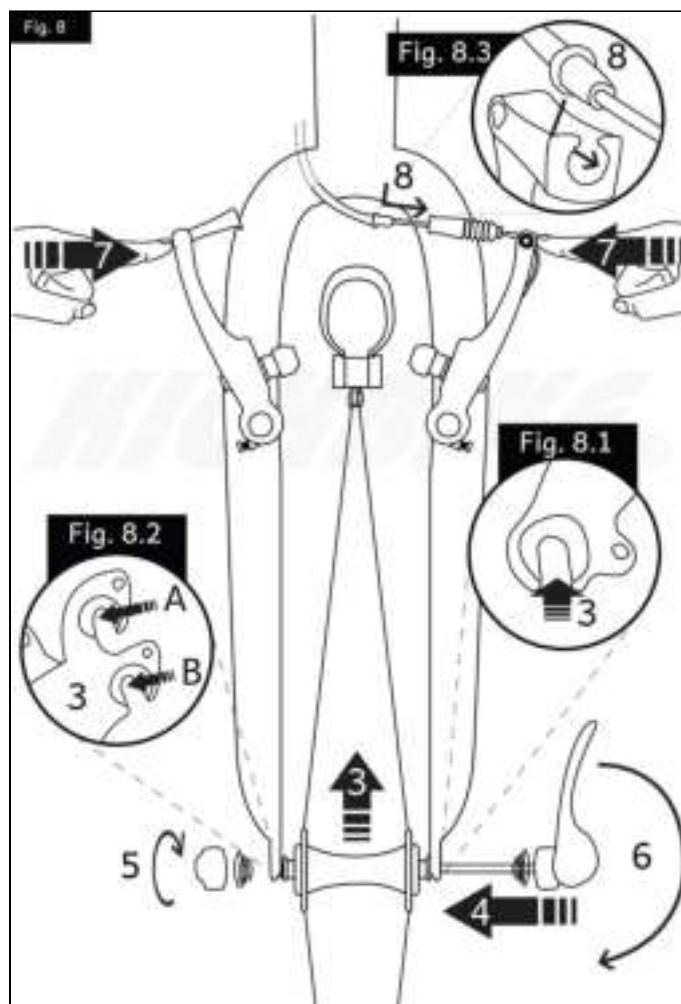
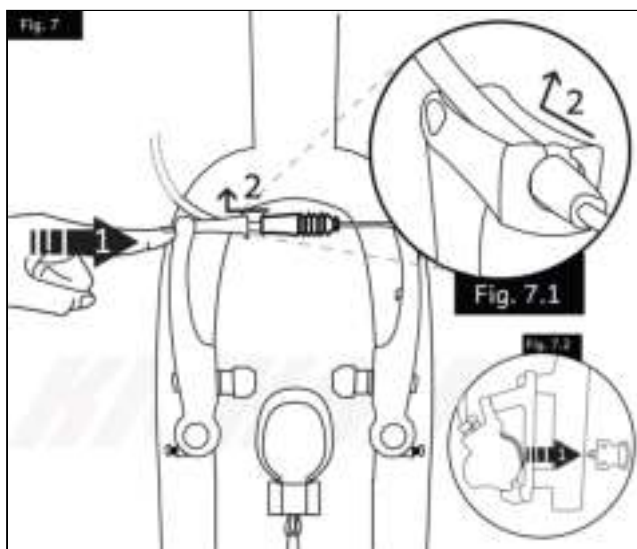

Inflate the tires

All models (Fig. 9)

1. Push/insert the pump on the valve
2. Turn pump's locking lever to "up" position
3. Pump
4. Open the locking lever before detaching the pump

Recommended air pressures (bar/PSI)

Freeride (3/45), City G4 (4/55), CliX (4/55), Sport G4 (5/ 75), Cross(3/45), FAT MAX (1/15), Cruise MAX 20 (3/45), Race (6/85).

*Note: Kickbikes come with **Auto/Schrader** valves so you can fill tires also on gas stations. If necessary, you can use inner tubes with other common valve types (**Presta/Scloverand** or **Dunlop**). Adapt pump to these valves by unscrewing the pump cap and turning rubber seal and plastic part around.*

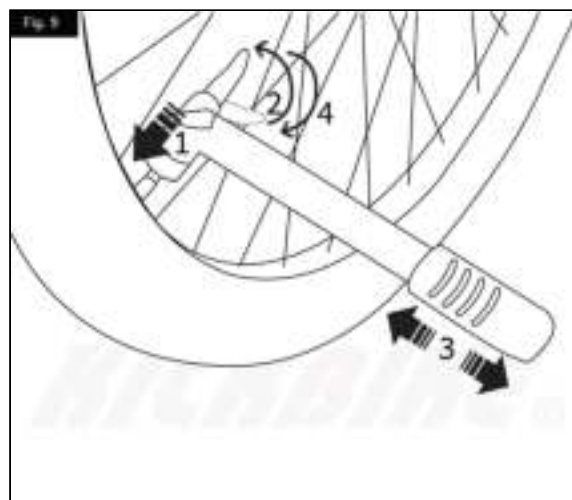

Adjustment of the brakes

V-brakes / Caliper-brakes

Freeride, City G4, CliX, Sport G4, Cruise MAX 20, Cross MAX 20V, Race MAX 20 (Fig. 10)

Race MAX 28 (Fig. 11, skip step 1 by checking that switch (A) is closed +)

1. Use bolt (A) to roughly adjust brake clearance if needed.
2. Use bolts (B) to align brake pads (E) with rims (D).
3. Squeeze brake levers to verify that brake pads (E) contact the rims (D) correctly (see Fig. 10.1).
4. Use screws (C) to center the brake (equalize the clearance from rim to both brake pads). In model **Race MAX 28** center the brake by moving whole brake frame by hand.
5. If you have small hands, use adjustment screw (Fig. 12 - A) to get brake levers closer to the handlebar. Use fine adjustment screw (Fig. 12 - B, Fig 11 - F) to get brake pads closer to rims if needed.
6. Test that the brakes work.

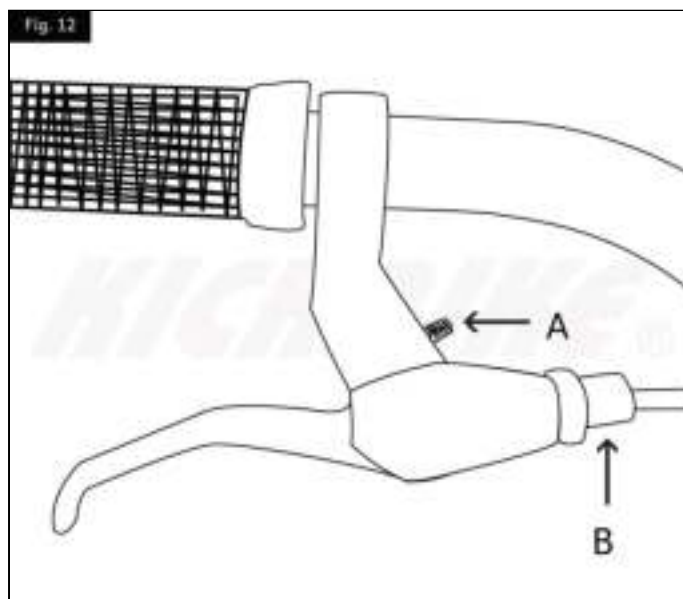
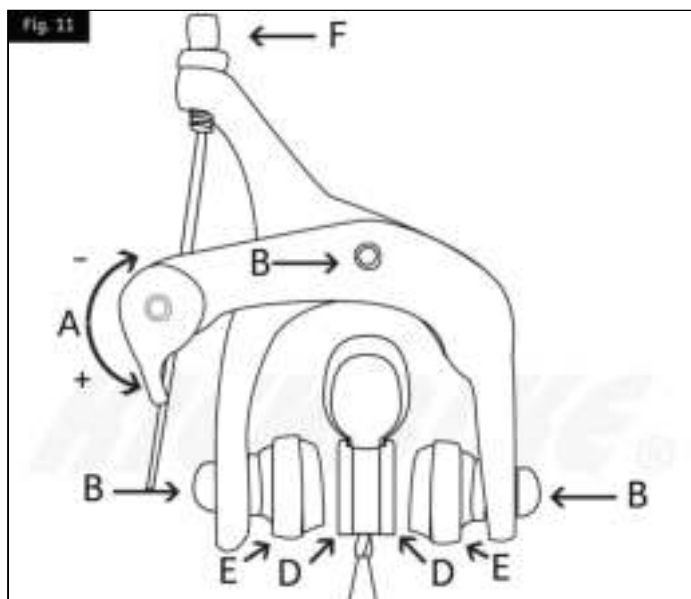
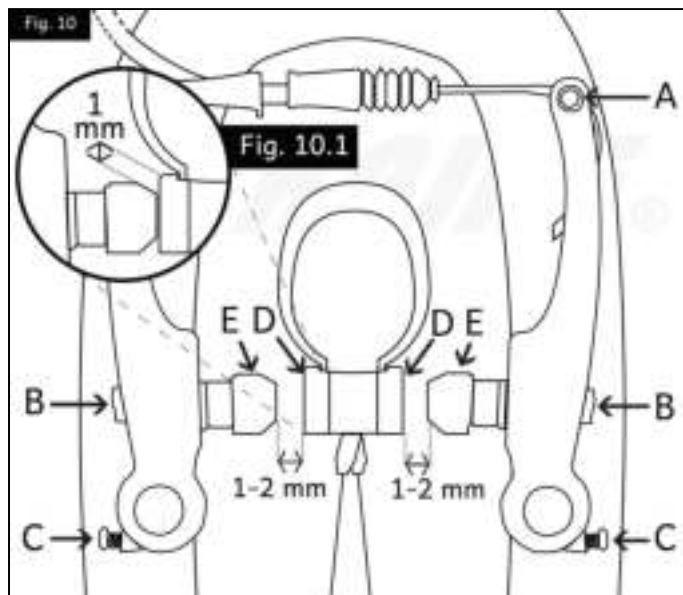

Disc brakes

Cross MAX 20D, Cross MAX 20HD, Cross 29er (Fig. 13)

1. Test if the brake is OK by rotating the wheel. If you hear the disc touching the brake, continue to next steps.
2. Loosen bolts (Fig. 13 - A)
3. Loosen adjustment hex screw (C) all the way and close it until you hear 6 clicks (Only mechanical disc brake system)
4. Squeeze brake lever to center the brake.
5. Tighten bolts (A) while holding the brake lever.
6. Loosen adjustment screw (C) until you hear 4 clicks (Only mechanical disc brake system)
7. Test again that disc is not touching the brake.
8. Test that the brakes work.

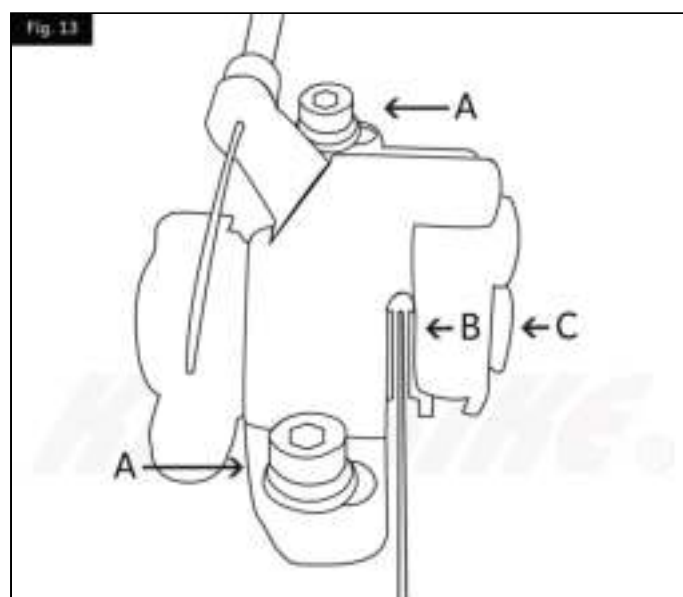

Footboard height adjustment

All Kickbike models have an option to choose low or high ride position. Low position (Fig. 14 A) is easier to kick as in the high position (Fig. 14 B) the frame has more ground clearance for safety. **Changing footboard height requires some adjustments!** Follow instructions at this page to change the position.

Default position in models **Race, Cruise** is low (A) and in **Cross, Sport G4, City G4, CliX, Freeride, FAT MAX** high (B)

note: Clix will stand upright in folded state only when footboard is in high position.

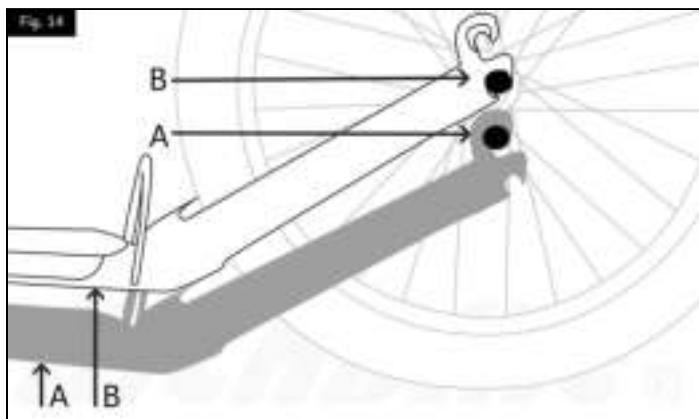

Changing the footboard height

1. Remove the rear wheel (inverse phases page 4)
2. Change the rear mudguard position if needed. High position (Fig. 6, position B) and low position (Fig. 6, position A)
3. In models **Cross MAX 20D, Cross MAX 20HD, Cross 29er, FAT MAX** adjust the position of the rear brake
 - 3.1. Choose high (Fig. 16 - F) or low position (Fig. 15 - E) adapter according to your setting and attach it to the frame (G) with screws (H)
 - 3.2. Attach brake (D) to the adapter. Washers (B and C) are optional for adjustment of the brake if needed (Fig. 13 - B).
4. Insert the wheel (see page 4)
5. Adjust the brake (see page 5)

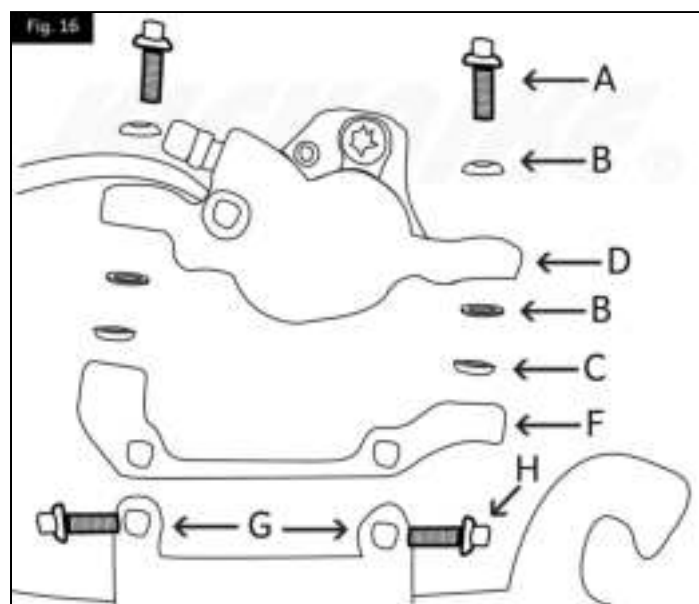
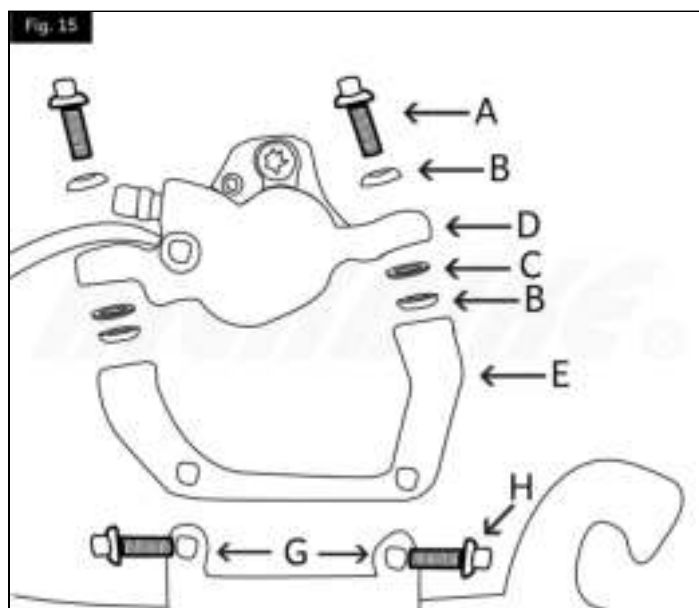

Kickstand adjustment

Freeride, City G4, Sport G4, Cross-models, FAT MAX, Cruise MAX 20 (Fig. 17)

1. Loosen the adjustment screw
2. Adjust the height of kickstand
3. Tighten the adjustment screw

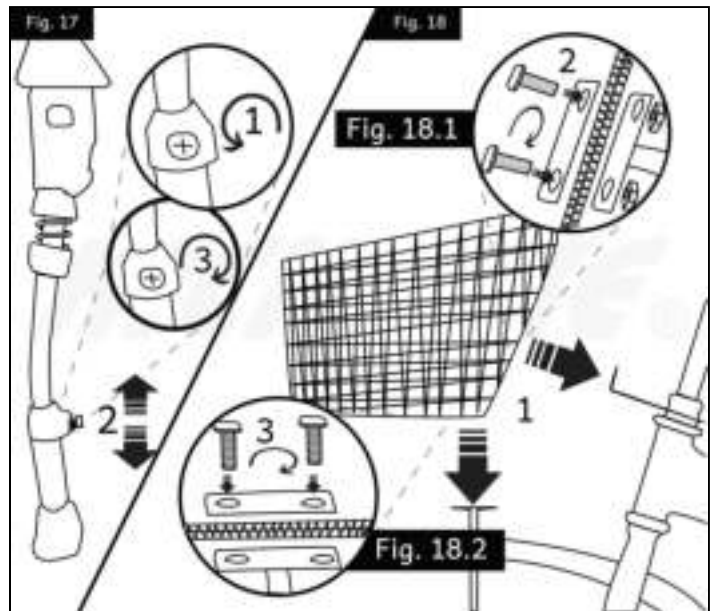

Basket installation

City G4 (Fig. 18)

1. Place basket into it's place
2. Tighten the bolts of frame mount (18.1)
3. Tighten the bolts of fork bracket (18.2)

Suspension fork

Cross MAX 20V, Cross MAX 20D, Cross MAX 20HD (Fig. 19)

You can lock the suspension fork if needed. **Cross MAX 20V** lock suspension from switch (Fig. 19, A) and **Cross MAX 20D, Cross MAX 20HD** from remote switch (Fig. 19.1, A) in handlebar.

Use the suspension preload adjustment switch (B) to adjust the suspension harder or softer.

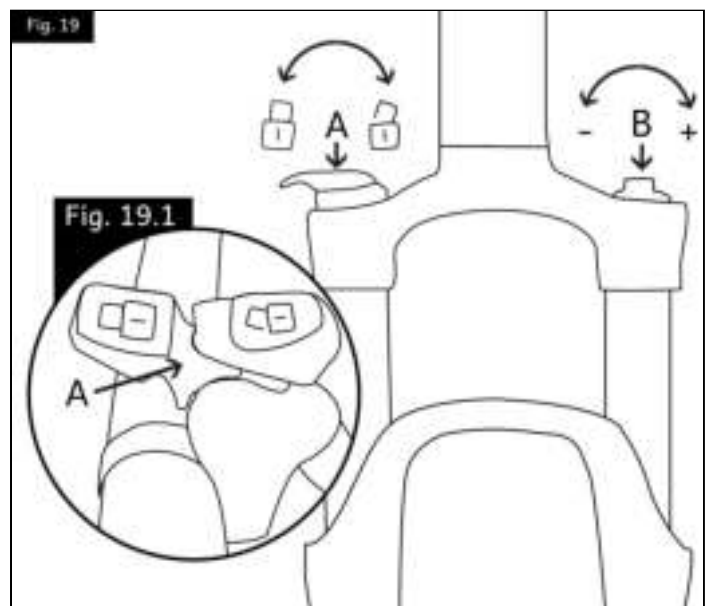

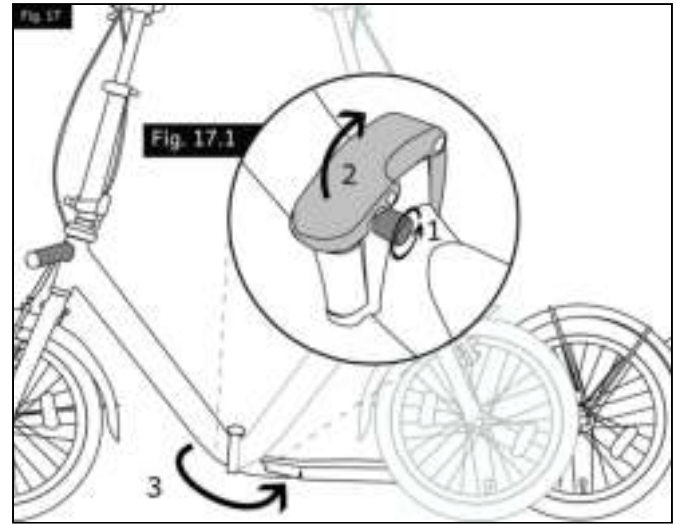
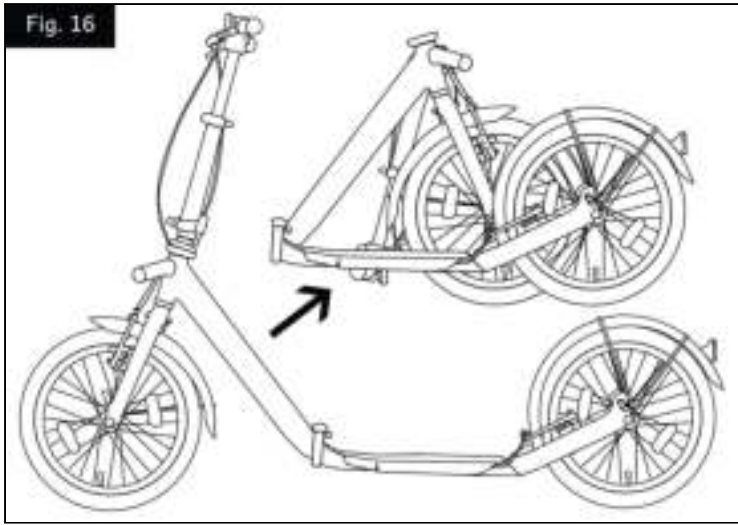

Fold & unfold CliX

CliX folds in two steps. First fold the frame (fig. 17)

1. Loosen the safety screw (fig. 17 screw 1)
2. Open the CliX frame joint latch. This can be operated with foot (handy if it's dirty or wet)
3. Fold the frame.

Then fold the handlebars (fig. 18).

1. Push up the lock button (fig. 18.1 button 1)
2. Open the latch all the way down (fig. 18.1 latch 2)
3. Fold down the handlebars

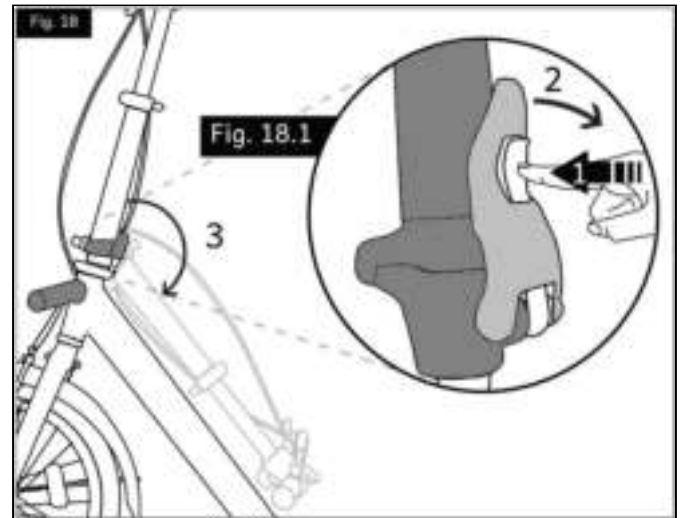

Carry CliX using the handle at the front of the frame. Handle is balanced so that CliX will stay folded by gravity without any locking mechanisms. This makes folding and unfolding as easy as possible.

To unfold CliX, reverse these steps.

1. Unfold the handlebars. Ensure that the quick release (fig. 18.1 latch 2) is fully closed. You should hear a 'click' when it locks.
2. Then unfold the frame (fig. 17) and close the CliX frame joint latch. Although CliX is rideable with the safety screw loose (fig. 17.1 screw 1), we recommend tightening it for your safety. Always check that all joints are solidly locked before riding CliX.

CliXstand

You can lean the CliX on a wall, fence, tree etc. when you lock the head set by turning the CliXstand ring counterclockwise to locked position (Fig. 19).

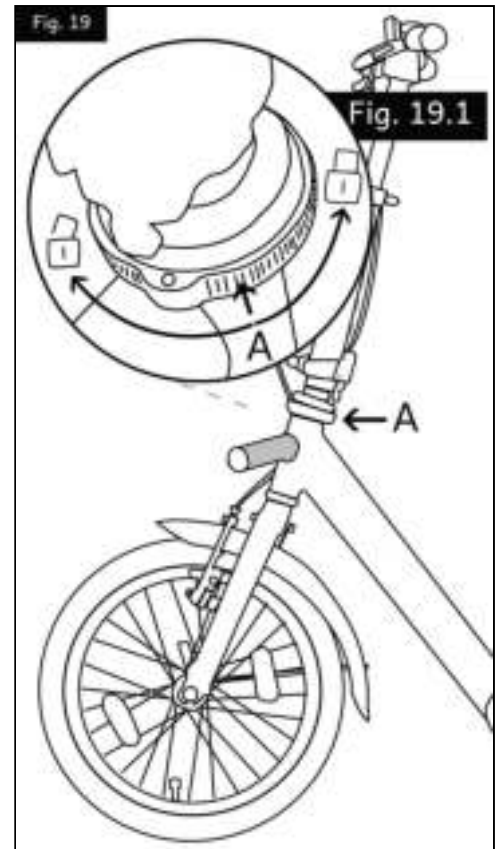

Maintenance

Even though the Kickbike is mostly a maintenance free transportation, it is recommended to perform a thorough inspection for loose bolts and spokes after first few hours of riding and also check the tire pressures and tightness of the screws and bolts of your Kickbike once in awhile. Also make sure that all the parts are in good condition. We recommend to take your Kickbike at least once in a year to an expert to get maintained.

Warnings

Shoelaces We recommend that you tie the shoelaces short and tuck the ends under laces to prevent them from catching brakes, quick release levers or other Kickbike parts while kicking.

Curbs The Kickbike footboard is low because it makes kicking easier. It will touch high curbs and speed bumps. Ride safe and slow initially, to get familiar to what kind of obstacles are rideable. If you are not sure whether the footboard will clear a bump, walk it over.

Helmet Remember to always use a helmet that fits you well and is an approved bicycle safety helmet.

Keep hands in handlebar Do not attempt to ride one handed. Use your leg instead if you need to signal a turn.

Warranty

We want to make sure that you are happy with our product. The Kickbike Worldwide warranty is 2 years for the frame and one year for other parts. Warranty does not include the normal wear and tear of brake pads, brake cables and tyres. The warranty does not cover problems, which are caused by the lack of maintenance by the user, improper usage of other than standard spare parts for the Kickbike, incorrect methods of maintenance or damages which are caused by normal usage of the Kickbike. The warranty does not cover small unnecessary damages where the strength and usefulness of the Kickbike is not affected. These damages include such as slight uneven paint/varnish/chrome coverage that are caused by the changing weather or/and the normal usage of the Kickbike. The warranty does not cover damages that have been caused by improper usage of the Kickbike, like jumping.

Tips

1. Take long "kicks" and enjoy smooth rolling of the Kickbike. It is important to straighten and relax the standing leg after every kick.
2. Switch the kicking leg every 4-10 kicks so you can go on forever!
3. Kick with your toes only - heel does not touch the ground.
4. Almost any outfit and shoes are good but avoid high heels and clothes that might catch moving parts while kicking. What is OK for running is OK for kicking.

See more tips and videos about kicking at www.kickbike.com

Kickbike Product Line



KICKBIKE®



Owner's manual

Language:
English

Models:
Freeride
City G4
Sport G4
Cruise MAX 20
Race MAX 20
Race MAX 2B
Cross MAX 20V
Cross MAX 20HD
Cross MAX 20HD
Cross 29er
FAT MAX

KICKBIKE WORLDWIDE LTD | +358 9 388 3013
Mikkolanle | A | 00040 HELSINKI | FINLAND
www.kickbike.com | info@kickbike.com

The Scooter Company

There's no better kick