

**Item No.: BUR.EC125**  
Installation guide

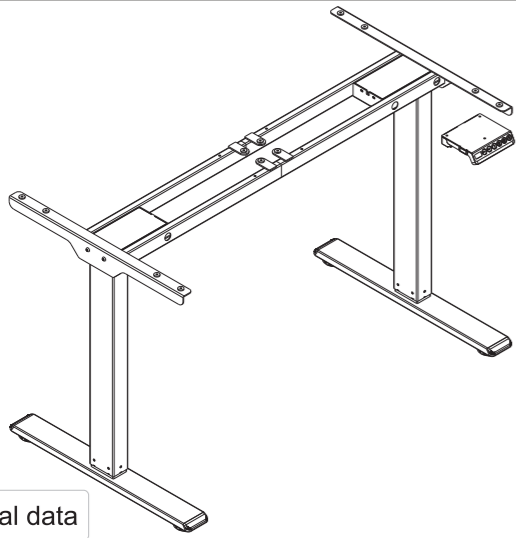

**Technical data**

Column Stage	3
Max. Load Capacity	100KG
Height Range	600-1250mm(Without tabletop)
Width Range	1100-1680mm

**Accessory list**

Attention: The drawings below are for guidance only and they may differ slightly from the product and fittings received. Please contact our customer service department if you have any queries.

No.	Image	Spec	Qty
A		M6	12
B		M6	8
C		St4.2	16
D		Cable tie	6
E		St4.2	6
F		Allen Key 4x4mm	1

**Component list**

No.	Part	Qty	No.	Part	Qty
①	Feet	2	②	Lifting Column	2
No.	Part	Qty	No.	Part	Qty
③	Connection Rod	2	④	Left Supporting Beam	2
No.	Part	Qty	No.	Part	Qty
⑤	Right Supporting Beam	2	⑥	Side Bracket	2
No.	Part	Qty	No.	Part	Qty
⑦	Handset	1	⑧	Screw for Handset	3
No.	Part	Qty	No.	Part	Qty
⑨	Adapter	1	⑩	Extension Cord	1

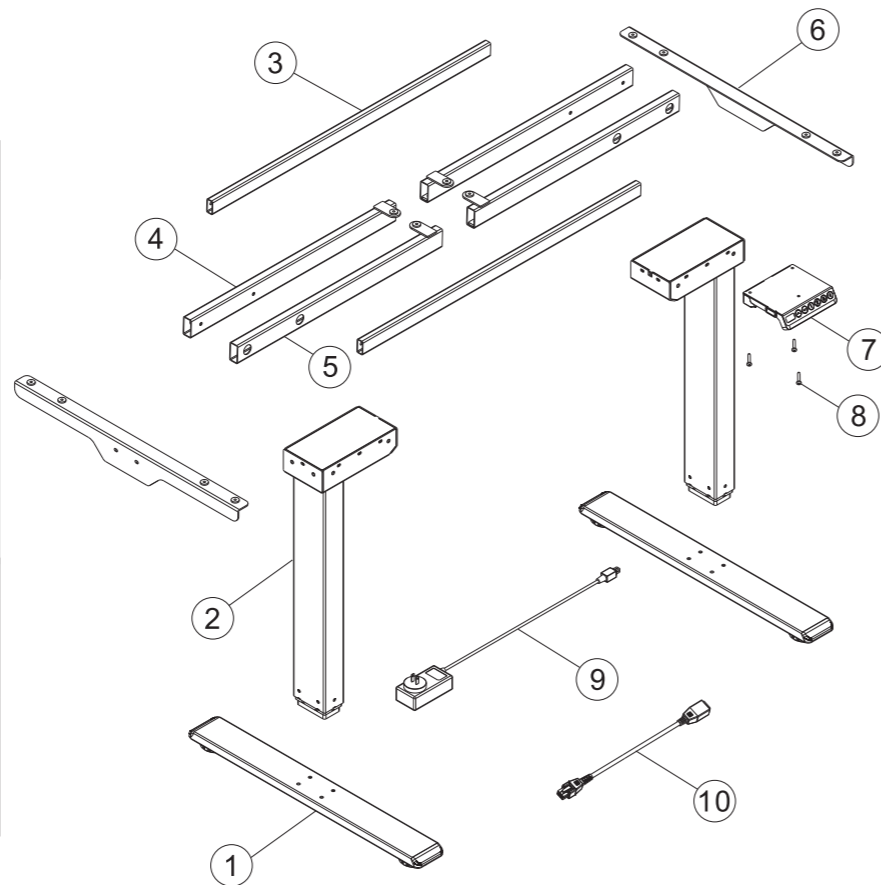

**STEP 1**

Install supporting beam

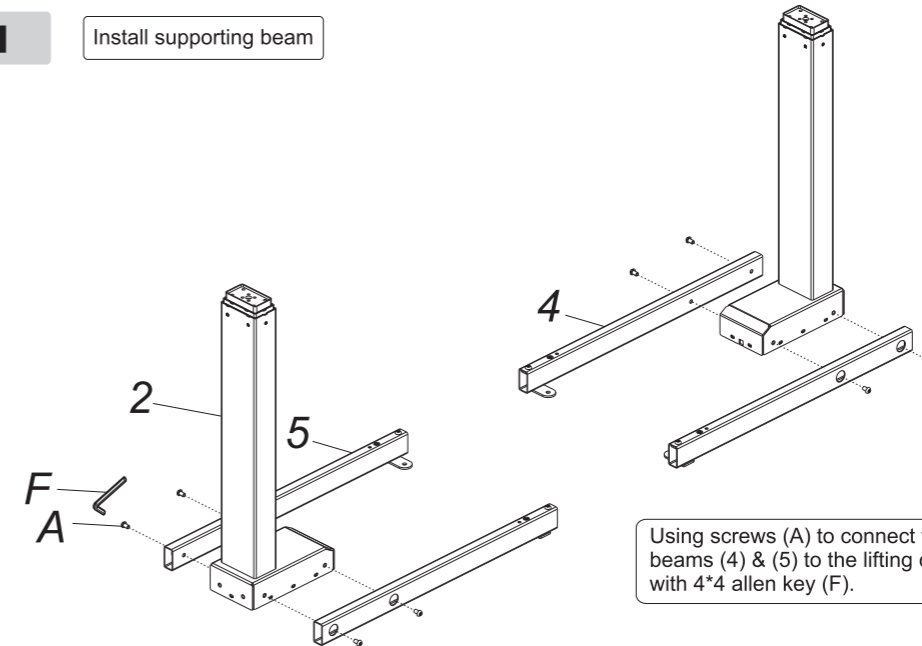

Using screws (A) to connect the left and right supporting beams (4) & (5) to the lifting column (2), and tighten them with 4\*4 allen key (F).

**STEP 2**

Install side bracket

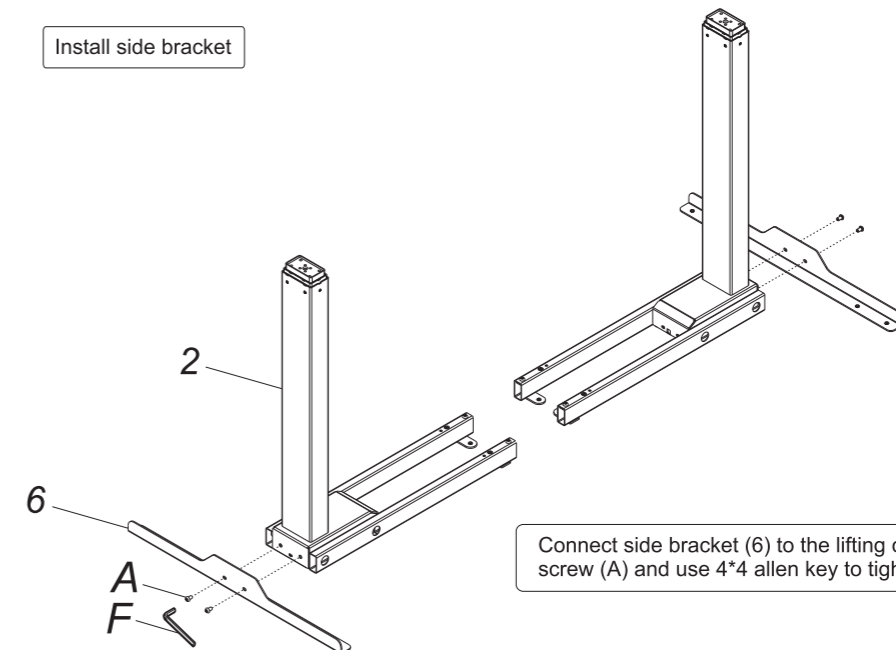

Connect side bracket (6) to the lifting column (2) with screw (A) and use 4\*4 allen key to tighten.

**STEP 3**

Install connection rod

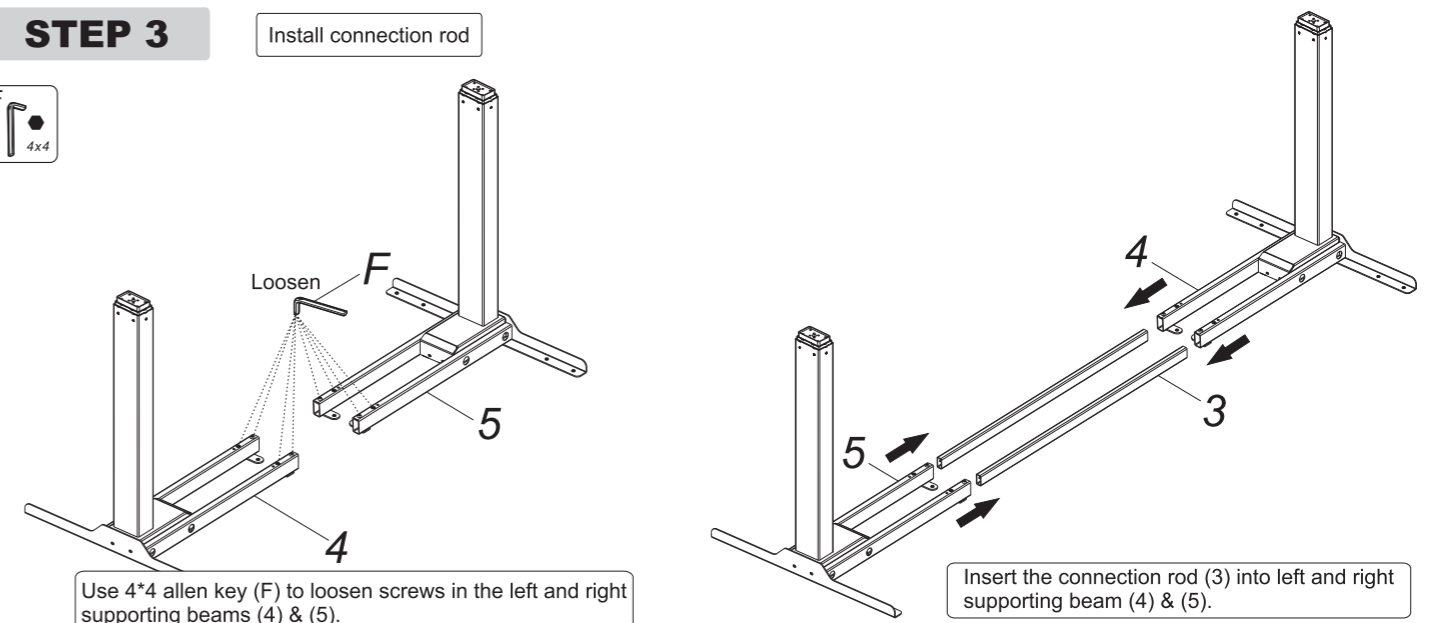

Use 4\*4 allen key (F) to loosen screws in the left and right supporting beams (4) & (5).

Insert the connection rod (3) into left and right supporting beam (4) & (5).

## STEP 4

Install feet

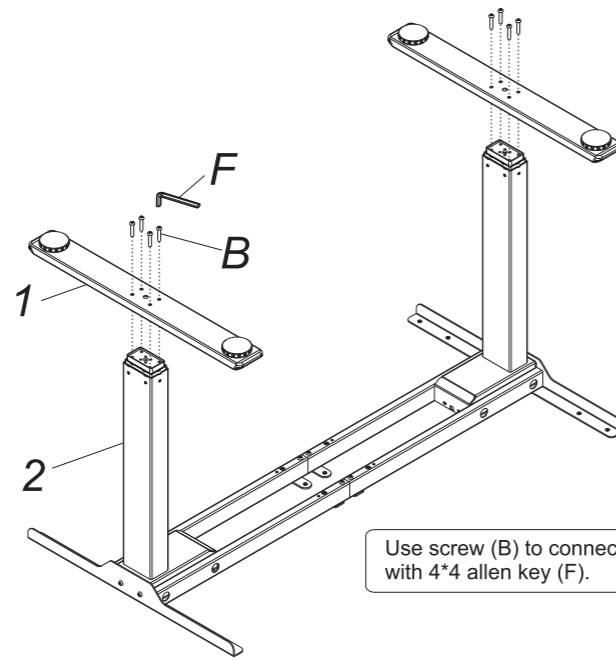
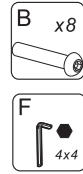

Use screw (B) to connect feet (1) & (2) and tighten it with 4\*4 allen key (F).

## STEP 5

Install tabletop and handset

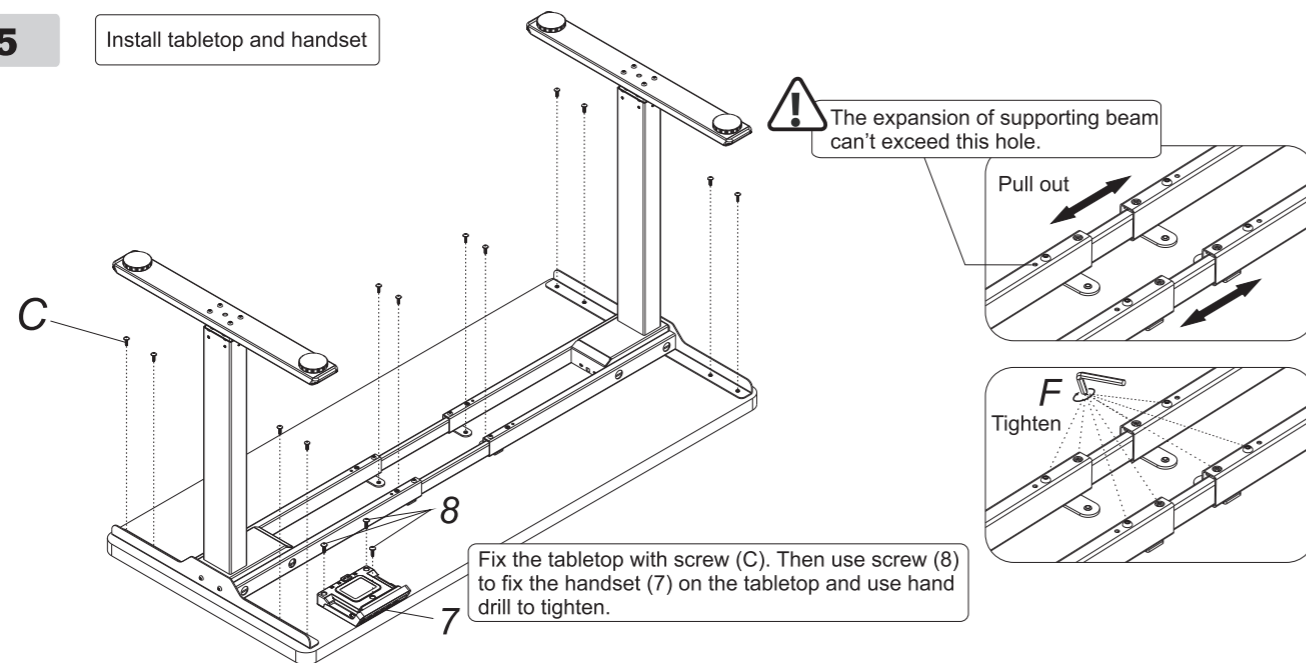

Fix the tabletop with screw (C). Then use screw (8) to fix the handset (7) on the tabletop and use hand drill to tighten.

## STEP 6

Connect cables to the handset

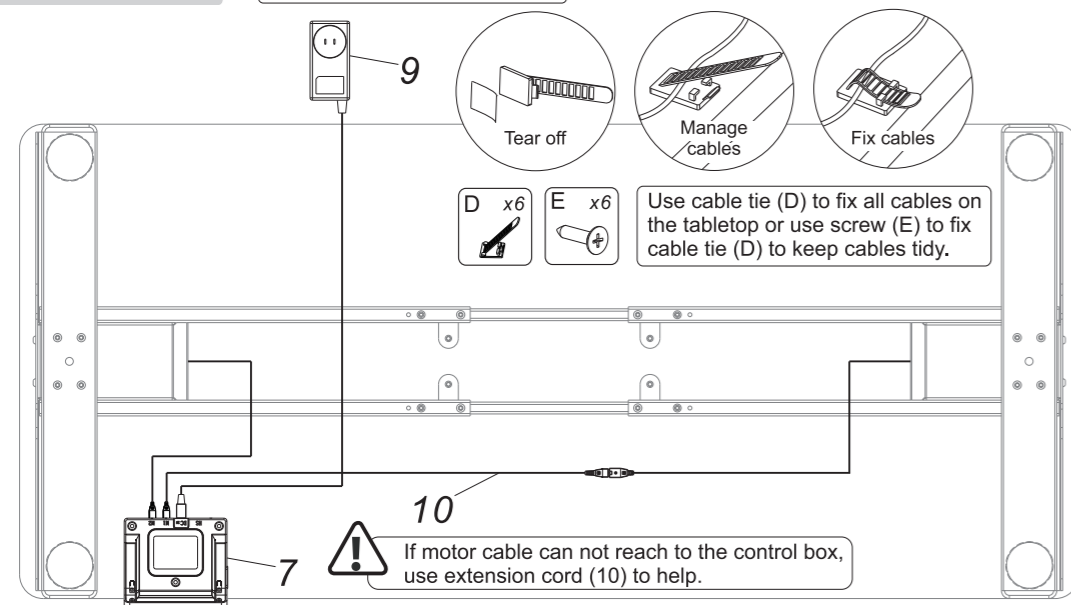

If motor cable can not reach to the control box, use extension cord (10) to help.

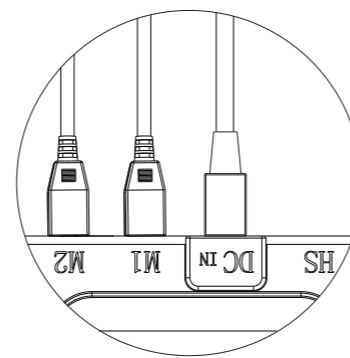

Connect adapter to the DC port

Connect motor cables to the M1 and M2 ports

## Common fault treatment

The following tips will help you detected and eliminate the common fault and error. If the fault you met is not listed below, please contact with your supplier. Only the manufacturer and professionals are capable for investigating and correcting those fault and error.

Fault phenomenon	Method
The desktop could not function	Check if all the cables well connected;
Rising in a low speed	Check if overloaded, max loading: 100kg;
The desk moving downwards without any operation	
Automatically Self-Reset	Reset;
Go down but not go up or go up but not go down	
The upper and downward height is not enough	
The desk could not lifted	Restart after suspend for 18mins while connecting with power.
Overwork (Duty cycle: Max 2min on/18min OFF)	



## Attention

1. Power supply: AC100V-240V,50/60Hz
2. Service Environment: 0-40°C
3. Unplug the power plug before cleaning, wipe the dust on surface with slight wet dishcloth when cleaning, be careful not to let the drops into the internal parts, not loose the connector.
4. The electric box contains electronic components, metals, plastics, wires etc., so dispose of it in accordance with each country's environmental legislation, not the general household waste.
5. Check carefully to ensure correct and complete assembly before using.
6. Be familiar with all functions and program settings of the product before first use.
7. Children are forbidden to play on the product because of unforeseen action when playing, so any dangerous consequences caused by this improper action will not be on manufacturers.
8. Slight noise caused by the V-ribbed belt or brake system due to structure will not have any effect on the use of the equipment.
9. Corrosive or abrasive materials are forbidden to clean the equipment. Must ensure that the cleaner used will not pollute the environment.
10. This appliance can be used by children aged from 8 years and above and persons with reduced physical, sensory or mental capabilities or lack of experience and knowledge if they have been given supervision or instruction concerning use of the appliance in a safe way and understand the hazards involved. Children shall not play with the appliance.
11. Cleaning and user maintenance shall not be made by children without supervision.
12. If the supply cord is damaged, it must be replaced by the manufacturer, its service agent or a similarly qualified person in order to avoid a hazard.
13. Please make sure there is no hazard sources in your operating environment. e.g., do not litter the tools around. Always be careful to treat the packaging materials in order to avoid any possible danger, e.g. plastic bag may lead to choking hazard to children.
14. Keep the original package of the equipment if necessary in case of the future use in transportation.

## Waste disposal



This marking indicates that this product should not be disposed with other household wastes. To prevent possible harm to the environment or human health from uncontrolled waste disposal, recycle it responsibly to promote the sustainable reuse of material resources. To return your used device, please use the return and collection systems or contact the retailer where the product was purchased. They can take this product for environmental safe recycling.