

Owner's Manual

C3i Upright Bike Interactive Trainer

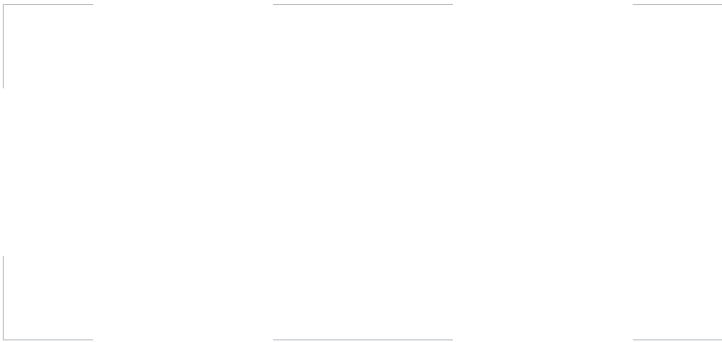

Congratulations on Purchasing Your LifeSpan C3i Upright Bike!

At LifeSpan we take pride in the quality, safety, and reliability of our products as well as the professionalism of our sales support and customer service teams. We make it our number one priority that you have an exceptional experience using our products.

In support of this quality focus we pre-assemble parts on the manufacturing line whenever possible to reduce the number of steps and complexity of customer assembly, independently certify our products to comply with the latest industry Safety Standards, and use state of the art production processes and quality components.

We back our products with excellent warranties and a responsive customer service department making it simple and easy to get assistance should the need arise.

This attention to quality, our high standard for customer service and focus on innovation has earned LifeSpan numerous awards and consistent praise from independent review groups, industry authorities and you the consumer.

Thanks for choosing LifeSpan.

Please thoroughly read this manual before you assemble or operate your upright bike. Neither LifeSpan nor its representatives can accept responsibility for any damages or injury incurred as a result of information presented in this manual except under the terms of the product warranty.

Welcome	
Safety First	6
<i>Safety First</i>	
About Your C3i Upright Bike	8
<i>Specifications</i>	
<i>Unique Features</i>	
<i>Console Overview</i>	
<i>Starting an Exercise Program</i>	
<i>Heart Rate Monitoring</i>	
<i>Programs</i>	
<i>Warranty / Registration</i>	
Assembling Your C3i Upright Bike	20
<i>Exploded View & Hardware</i>	
<i>Assembly Instructions</i>	
Console Basics	32
<i>Console Buttons / Date & Time</i>	
<i>Display Console Window</i>	
<i>Quickstart</i>	
Using Programs	36
<i>Manual Mode</i>	
<i>Custom User</i>	
<i>My Zone Heart Rate Control Programs</i>	
Saving Your Results	40
<i>Saving Your Results</i>	
Maintenance and Tips	41
<i>Engineering Mode</i>	
<i>Troubleshooting</i>	
<i>General Maintenance</i>	
<i>Moving</i>	

Safety First

When using exercise equipment, basic precautions should always be followed, including:

- Never drop or insert any object into any opening. If an object falls into an opening, unplug the power cord from the outlet. Remove the object or call customer service at 877.654.3837 option 4.
- Never operate this upright bike if it has been damaged or partially submerged in water.
- To reduce the risk of electric shock, unplug the upright bike from the wall outlet when not in use, before performing any maintenance, or before moving the upright bike.
- Do not use outdoors or in areas of high humidity or extreme temperature changes.
- Do not operate where aerosol spray products are being used or where oxygen is being administered.
- Never place the power cord under carpeting or place any object on top of the cord, this may pinch or damage the cord causing fire damage or personal injury.
- Use this exercise product for its intended use as described in this Owner's Manual. Do not use attachments that are not recommended by LifeSpan.
- Keep hands away from all moving parts
- Keep your upright bike on a solid, level surface. Do not operate upright bike on deeply padded, plush or shag carpeting. Damage to carpeting may occur.

Children and Pets

- When in use children and pets should be kept at least 10 feet (3m) away.
- This upright bike can be used by children ages 12 years and above and persons with reduced physical, sensory or lack of experience and knowledge if they have been given supervision or instruction concerning use of the appliance in a safe way and understand the hazards involved.
- Cleaning and user maintenance shall not be made by children without supervision.
- Keep children away from the upright bike. There are areas that can cause harm and injury.

Safety Tips While in Use

- Always consult a physician before beginning an exercise program.
- If you experience chest pains, nausea, dizziness or shortness of breath, stop exercising immediately and consult your physician before continuing. Do not wear clothing or jewelry that might catch on any part of the upright bike.
- Wear shoes with high traction rubber soles. Do not wear shoes with heels, leather soles, cleats or spikes.
- Heart Rate monitoring systems may be inaccurate. Various factors, including the user's movement may affect the accuracy of the heart rate readings. The pulse sensors are intended only as exercise aids in determining heart rate trend.
- Over exercising may result in serious injury or death. If you feel faint stop exercising immediately.

NOTE: Read all instructions and save for future reference.

About Your C3i Upright Bike

Specifications

Mechanical and Performance

Seat	Molded, contoured seat
Seat Adjustment	Height - 19 positions
Resistance System	Magnetic - Eddy Current
Pedals	Self balancing
Flywheel Weight	18 lbs (8.1 kg)
Max. User Weight	400 lbs (181.4 kg)
Dimensions	43" x 28" x 56" (109.2 cm x 71.1 cm x 142.2 cm)
Transport Wheels	Rear Mounted

Console Features

Readouts	Program Name, Date and Time, Workout Time, Calories, RPM, Distance, Heart Rate, Speed, Resistance Level (Load), Watts
Programs	Manual, Preset (17), User Set-up (2), Heart Rate Control (2)
Display	Multi-Color LCD
Heart Rate	Grip Pulse and Receiver (chest strap is not included)
Audio	Audio Center with in / out jacks and integrated speakers
Program Matrix	16 Row by 20 Columns
Program Buttons	5 Program Group Buttons for Heart Rate Control, Healthy Living, Sports Training, Weight Loss and User Set-up Programs
Levels of Resistance	16 Levels

Unique Features

As a leader in the fitness industry, LifeSpan has developed a number of unique features that make our products more engaging and easier to use. You can learn more about how to use these features throughout this Owner's Manual.



Intelli-Key™

Console operation is simplified with sequential button illumination prompting you through program selection and setup.



Club Membership

Every C3i Upright Bike comes with a full membership in the Club, LifeSpan's award-winning health and fitness software. Keep track of all your activity and information in one secure location. Go to www.lifespanfitness.com/apps/club/ to enroll.



USB Port

The C3i includes a USB port that works with LifeSpan Club account. After loading your profile from the Club onto the USB flash drive, simply insert your flash drive into the console. The USB will read your personal information and then save your workout data every 20 seconds onto the flash drive. Information saved includes your heart rate, workout start and finish time, distance traveled, calories burned and RPM's. This information can then be uploaded into your account, summarized over time and used to compare your results with the goals you set in your personal Club account.

Do not remove the USB flash drive while the LED light is flashing red - you may lose your workout information.

Audio Package

Included are audio in and audio out jacks to use with MP3 players or other audio devices with standard input jacks.

About Your C3i Upright Bike

Console Overview

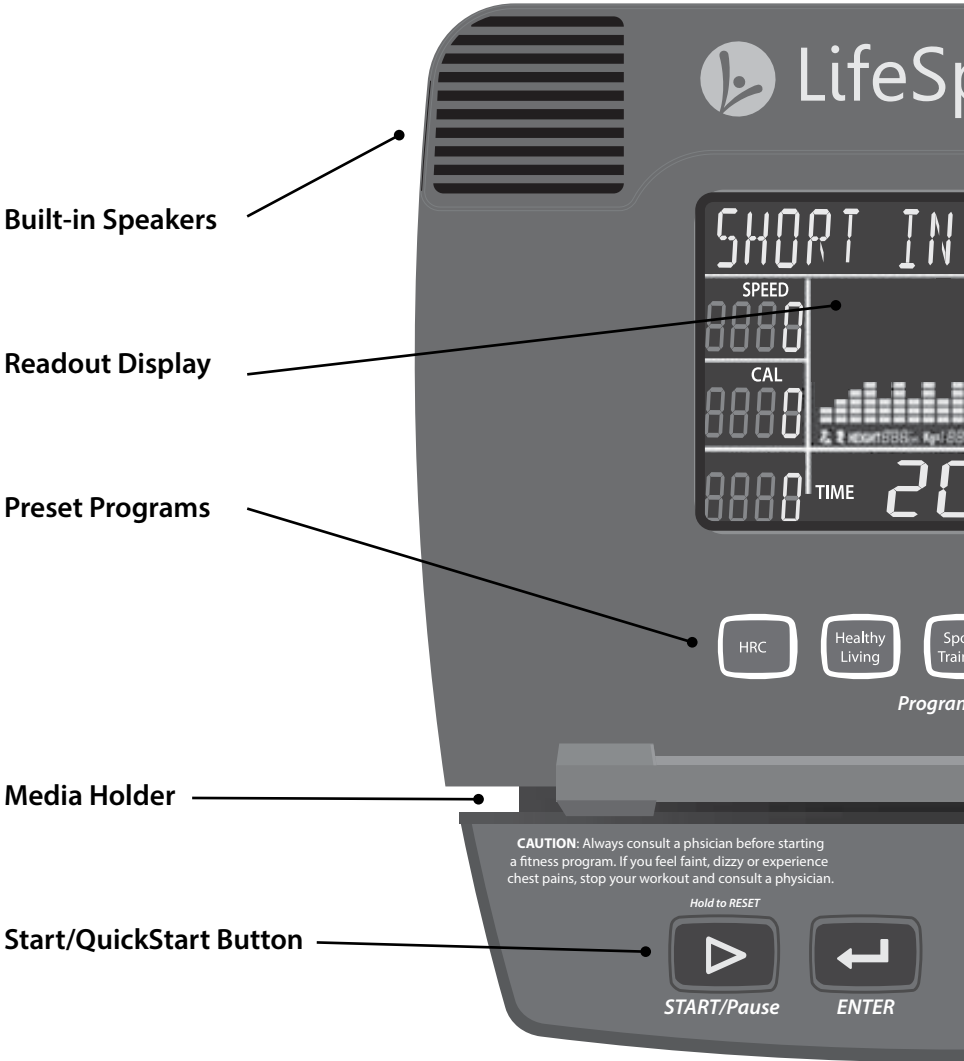

About Your C3i Upright Bike

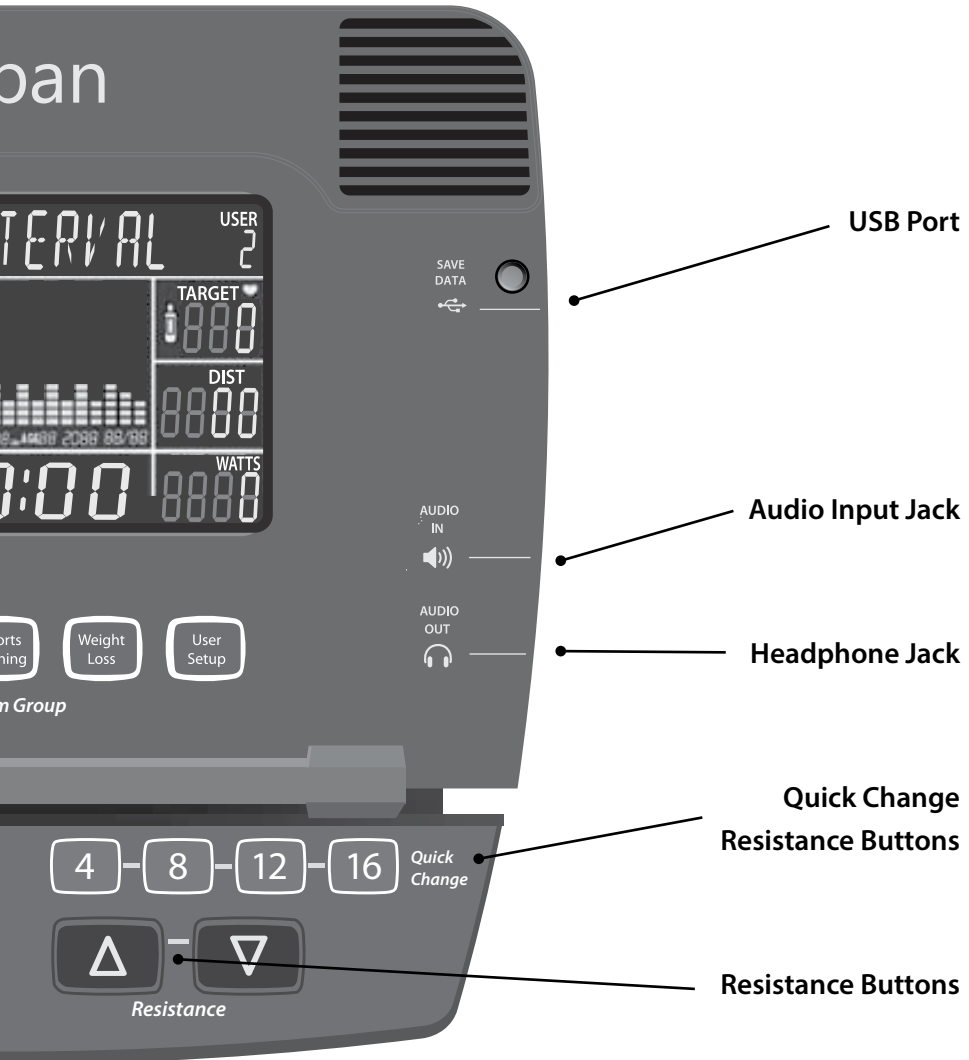

About Your C3i Upright Bike

Starting an Exercise Program

Starting an exercise program can sound like a daunting task, but just remember that your main goal is to boost your health by meeting the basic physical activity recommendations.

Before you begin an exercise program, or substantially increase your level of activity, be sure to consult your primary care physician. In preparation for a visit you may also want to take the PAR-Q Assessment. The Physical Activity Readiness Questionnaire (PAR-Q) will help you determine your suitability for beginning an exercise program and prepare you for discussing your physical activity program with your physician.

1. Has your doctor ever said that you have a heart condition or that you should participate in physical activity only as recommended by a doctor?
2. Do you feel pain in your chest during physical activity?
3. In the past month, have you had chest pain when you were not doing physical activity?
4. Do you lose your balance because of dizziness?
5. Do you ever lose consciousness?
6. Do you have a bone or joint problem that could be made worse by a change in your physical activity?
7. Is your doctor currently prescribing drugs for your blood pressure or a heart condition?
8. Do you know of any reason you should not participate in physical activity?

If you answered yes to one or more of the questions, if you are over 40 years of age and have been inactive or if you are concerned about your health, consult a physician before beginning an exercise program or substantially increasing your physical activity. If you answered no to each question then it's likely you can begin an exercise program.

Heart Rate Monitoring

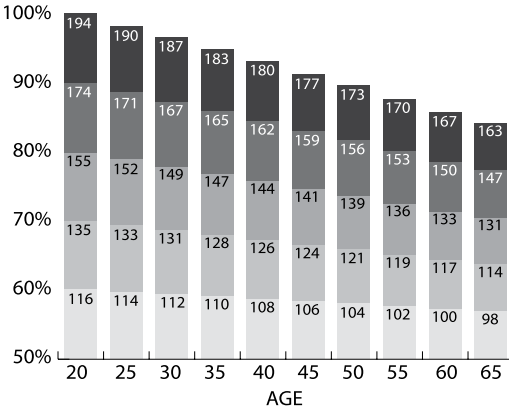

Seeing your heart rate while exercising will help you understand the intensity of your exercise and corresponding heart rate training zone, and predict health benefits found through repeated bouts of exercise. Refer to the information below to understand your heart rate training zones:

Zone 5 — Performance Redline Zone: 90% - 100% of your Max HR

The performance zone involves extreme effort, requiring the heart to beat at or near maximum capacity. Training bouts include intense incline or sprinting, benefiting speed, power, and anaerobic performance competency.

Zone 4 — Threshold Zone: 80% - 90% of your Max HR

The threshold zone involves intense jogging or sub-maximal sprinting, typically unsustainable for long periods of time. Benefits include highly-elevated calorie burn, speed and power performance enhancement, improved lactate removal capabilities, and enriched heart health.

Zone 3 — Aerobic Zone: 70% - 80% of your Max HR

The aerobic zone is ideal for cardiovascular training. Workouts in this zone are more intense, involving moderate jogging. Long-term benefits are improved heart health and cardiovascular performance, reductions in blood pressure and cholesterol, and increased calorie burn.

Zone 2 — Temperate Zone: 60% - 70% of your Max HR

The temperate zone consists of moderate-intensity exercise, typically as fast walking to slow jogging. Speaking is more difficult and breathing is elevated. Benefits are similar to those of the healthy heart rate zone, though caloric expenditure is higher.

Zone 1 — Healthy Heart Zone: 50% - 60% of your Max HR

The healthy heart zone involves safe, low-intensity activity, like medium-to-brisk walking. Full conversations can be held, despite a gentle increase in respiration. Benefits include reduced risk of heart and vascular disease, moderated blood pressure and cholesterol, and improved insulin sensitivity.

About Your C3i Upright Bike

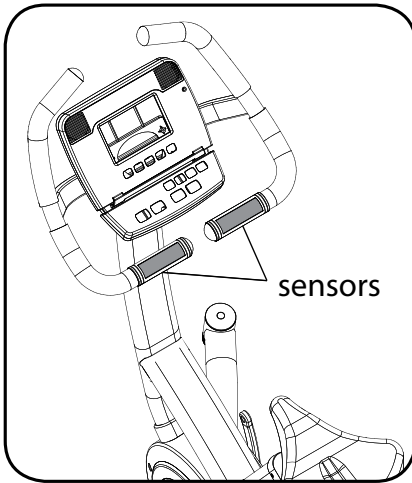

Reading Your Heart Rate

Contact Heart Rate Sensors are built into the stationary hand grips of the C3i to monitor your heart rate during exercise. To use, grasp the sensors with a comfortable grip with the palms of your hands placed over the sensors. If the sensors are having difficulty picking up your heart rate you may consider using aloe or a moisturizer on your hands, or you can warm up as you exercise to increase the moisture in your hands. Dry hands do not transfer your pulse as effectively as moist hands.

Do not squeeze tightly as this can cause your blood pressure to rise. It will take a few seconds for the console to calculate your heart rate accurately.

Chest Strap

The C3i Upright Bike has an integrated heart rate receiver built into the console. To purchase a heart rate chest strap go to www.LifeSpanFitness.com.

The chest strap should be worn as shown.

When using a chest strap you may need to warm up first to increase the moisture in your skin. If this doesn't work use aloe or another moisturizer where the sensors on the chest strap are making contact with your skin.

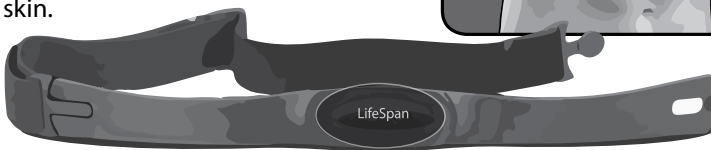
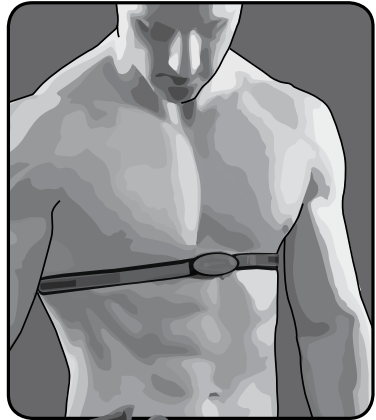

NOTE: The heart rate monitoring system will vary due to your age, method of use, physiology and other factors. LifeSpan cannot guarantee the accuracy of the heart rate readings.

Preset Programs

Preset programs automatically change the resistance level during a workout according to a preset pattern called a profile. This provides a better workout, since it uses a wider range of muscles and different intensities, a well-known benefit in the cross-training and interval-training world.

Each preset program can be set to change the resistance level. Each has a suggested duration which can be adjusted to anywhere from 10 to 99 minutes. Two overall levels may be selected, which raises or lowers the program profile.

Changing the resistance level changes which muscles are used. Adjust the resistance level to your personal preferences, or to target different muscles.

Long Slow Distance

(40 minutes default)



This profile has small changes, allowing for a more consistent style of effort, maximizing the duration of your workout.

Short Interval

(20 minute default)



This has the widest variation of resistance level, and has the shortest default duration.

Moderate Interval

(30 minute default)

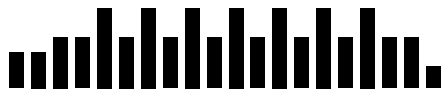

Smaller resistance changes than Short Interval, but greater overall duration, resulting in a longer workout.

Long Interval

(40 minute default)

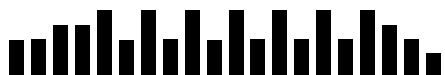

The smallest resistance alterations of any of the interval workouts, allowing a longer overall duration.

About Your C3i Upright Bike

Negative Interval 1

(30 minute default)

A good choice for someone new to interval training. Resistance levels decrease in the second half of the workout.



Negative Interval 2

(30 minute default)

A slightly higher-intensity version of Negative Interval 1.



Fartlek

(30 minute default)

A Fartlek is a Swedish workout that inspires improved levels of fitness through unpredictable changes in programming. This profile purposefully has no predictable pattern to its profile.

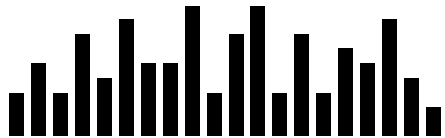

Uphill Climb

(30 minute default)

A gradual increase, then corresponding decrease of resistance.

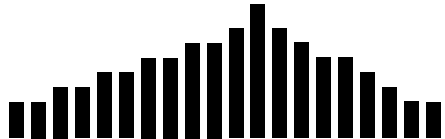

Pyramid Climb

(30 minute default)

Similar to Uphill Climb but with less frequent changes.

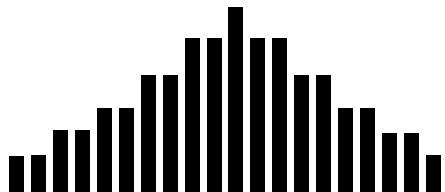

Plateau Climb

(40 minute default)

A higher-intensity version of Long Slow Distance, with a steady level of effort comprising the majority of the profile.

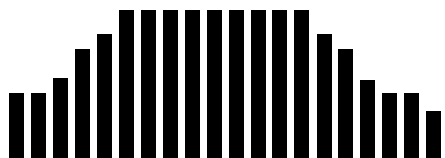

Ladder

(30 minute default)

A form of interval training with longer, increasingly-intense

intervals. Each unique, altering level is designed to mimic a higher rung on a ladder. This is the most difficult of the preset programs.



Uphill Interval

(20 minute default)

Similar to Short Interval, but with more pronounced changes in intensity.

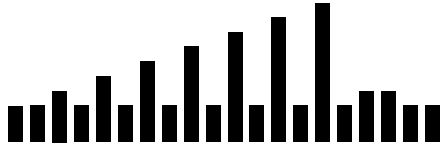

Steady Pace

(40 minute default)

Similar to Long Slow Distance, but with a lower intensity, steady profile. This is the easiest of the preset programs.



Long Slow Distance 2

(40 minute default)

Similar to Long Slow Distance, but reaches maximum intensity more rapidly.



Cardio Ride

(20 minute default)

A short, continuous workout with consistently high intensity.



Short Interval 2

(20 minute default)

Similar to Short Interval, but with a more rapid buildup to the initial interval.

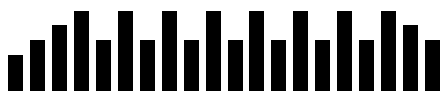

About Your C3i Upright Bike

Uphill Climb

(30 minute default)

Gradually increases intensity throughout the entire workout.

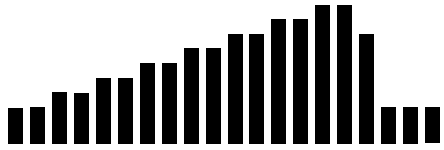

About Your C3i Upright Bike

Warranty

This LifeSpan upright bike comes with the following limited warranty valid in North America and the United Kingdom. If you are outside of these areas contact your local distributor for warranty information or visit www.LifeSpanFitness.com.

	Residential	Commercial (4 hr/day)
Frame	Lifetime	5 Years
Parts	5 Years	2 Years
Labor	2 Years	1 Year

LifeSpan warrants that the equipment it manufactures is free from defects in materials and workmanship under normal use and services. The periods above are based on the date of purchase. During these periods, LifeSpan will repair or replace any defective part. Free labor is included on all parts that are not normally assembled or replaced by the customer within the labor period.

If within the time frames specified above, any part fails to operate properly, login to our website at www.LifeSpanFitness.com, click on "Customer Service" and complete the form to request assistance or call 877.654.3837 option 4 for a Customer Service Agent (please note that certain kinds of service should only be performed by a qualified service technician).

LifeSpan reserves the right to make changes and improvements to our products without incurring any obligations to similarly alter any product purchased. In order to insure our product warranty and to ensure the safe and efficient operation of your LifeSpan product, only authorized parts can be used. The warranty is void if any parts other than those provided by LifeSpan are used.

Exclusions and Limitations:

- This warranty does not apply to any defects caused by negligence, misuse, improper assembly, or maintenance, accident, or "act of God."
- This warranty does not apply to discoloration of paints or plastics.
- LifeSpan shall not be responsible for incidental or consequential damages.
- This warranty is non-transferable from the original owner.

Registration

Should you need to process a warranty claim make sure you retain your purchase receipt to verify the date of purchase and register your LifeSpan product online. To complete the registration go to www.LifeSpanFitness.com and select "Product Registration".

Assembling Your C3i Upright Bike

Exploded View

Prior to starting the assembly process take all of the parts out of the box. Remove plastic bags and lay them out on the floor to become familiar with the components.

Since your upright bike is a heavy piece of equipment it is recommended you use two people during assembly and follow these assembly instructions to reduce any problems that could occur.

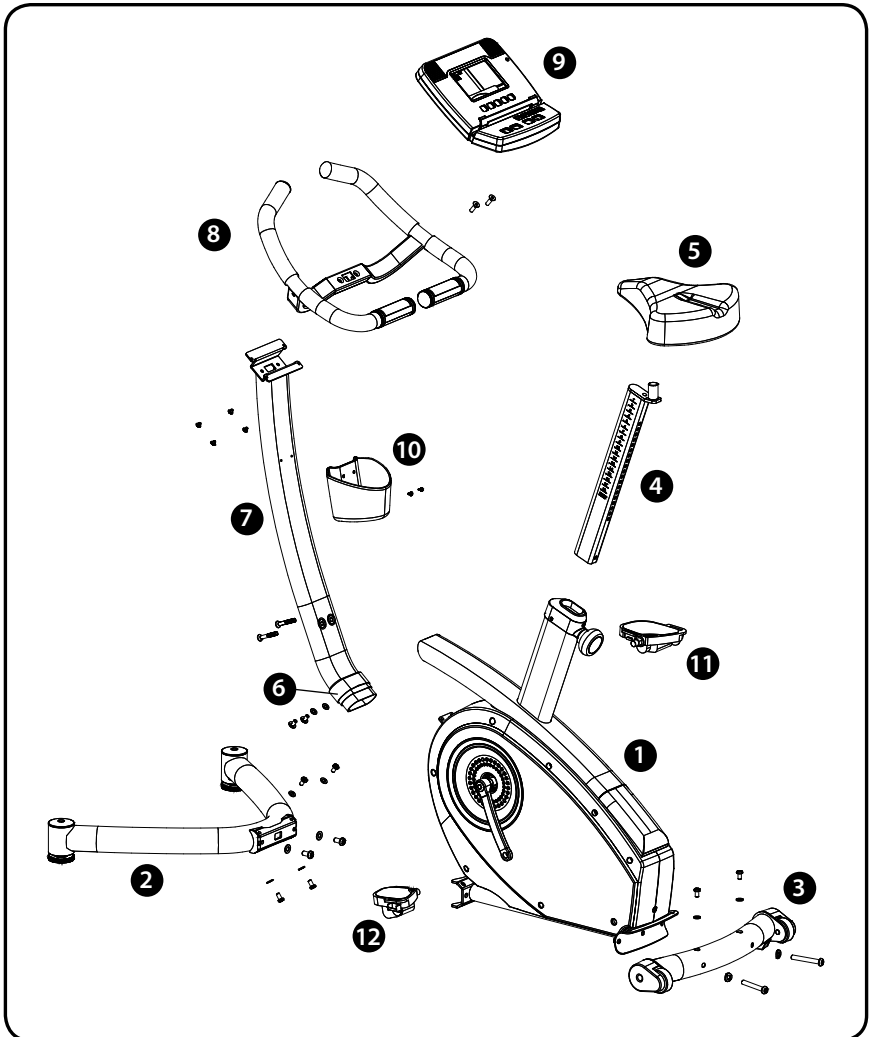

Assembling Your C3i Upright Bike

Hardware Included

Item#	Part Description
1	Main Frame
2	Front Support
3	Rear Support
4	Seat Post
5	Seat
6	Lower Console Mast Cover

Item#	Part Description
7	Console Mast
8	Handlebar Assembly
9	Console
10	Storage Tray
11	Right Pedal
12	Left Pedal

Hardware Bag Contents

Item #	Qty.	Hardware Description
13	2	M8 x 70L Bolt
14	2	M8 Curved Washer
15	2	M8 x 15L Bolt
16	2	M8 Washer

Item #	Qty.	Hardware Description
19	2	M8 x 55L Countersink Bolt
24	1	Multi-Wrench - 10, 13, 14, 15, 17, 22 mm
25	1	Allen Wrench - 5mm

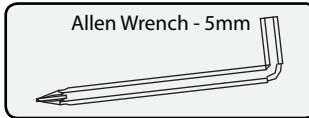
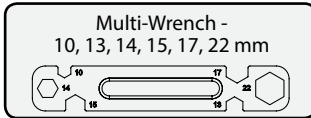
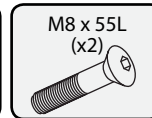
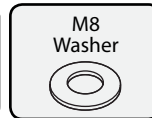
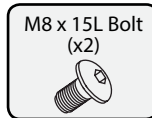
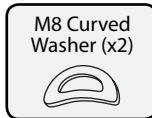
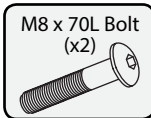

Pre-installed Hardware

Hardware will need to be removed and re-installed during the installation process

Item #	Qty.	Pre-Installed Hardware
14	2	M8 Curved Washer
15	8	M8 x 15L Bolt
16	6	M8 Washer

Item #	Qty.	Pre-Installed Hardware
20	2	M8 x 30L Countersink Bolt
21	4	M4 x 10L Screw
22	2	#8 x 5/8" L Screw

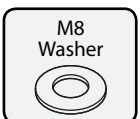
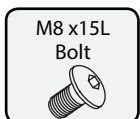

Assembling Your C3i Upright Bike

Step 1: Remove Components from Box

- A. Remove plastic bags and lay all parts out on the floor.
- B. Locate the hardware bag.

Step 2: Rear Support Assembly

- A. Place the *Main Frame Assembly (1)* on a solid level surface. It may be necessary to prop the back of the frame up slightly to give clearance for step B.
- B. Align the *Rear Support Assembly (3)* with the *Main Frame Rear Bracket (A)*.
- C. Install two long *M8x70L Bolts (13)* and *Curve Washers (14)*, found in the hardware bag, through the *Rear Support Assembly (3)* and into the *Main Frame Rear Bracket (A)*. **Do not tighten bolts yet.**
- D. Insert two *M8x15L Bolts (15)* and *Curved Washers (14)* through the top of the *Main Frame Rear Bracket (A)* and into the *Rear Support Assembly (3)*. **Do not tighten bolts yet.**
- E. Securely tighten the two long *M8x70L Bolts (13)* first, then tighten the two *M8x15L Bolts (15)*.

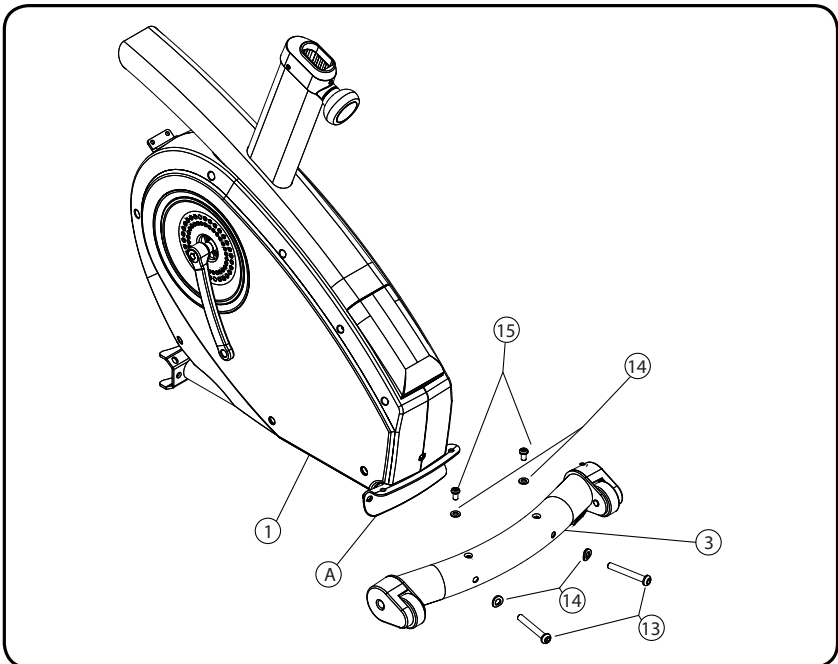

Step 3: Seat Assembly

- A. Insert the *Seat Post* (4) into seat post cover. The holes in the *Seat Post* should be pointing toward the rear of the bike.
- B. Pull on the *Seat Post Adjustment Knob* (M) to release the locking pin and slide the *Seat Post* (4) down into the *Seat Post Tube* (L).
- C. When the desired height is reached, release the *Seat Post Adjustment Knob* (M) to allow the locking pin to engage.

NOTE: In order to complete Step 5 and 6, the seat post needs to be set to the highest level. Pull the seat post up until the lock pin clicks in the last hole in the seat post.

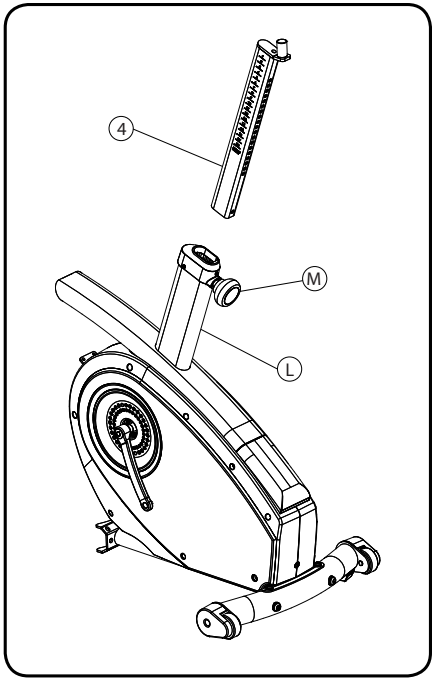

Step 4: Seat Assembly

- A. Place the *Seat* (5) over the *Seat Mount Post* (N).
- B. Align the *Seat* (5) so the front of the seat is centered with the *Console Mast* (7) and parallel to the floor.
- C. Securely tighten the pre-installed *Nut* (23) on each side of the *Seat Mounting Bracket* (O) under the *Seat* (5).

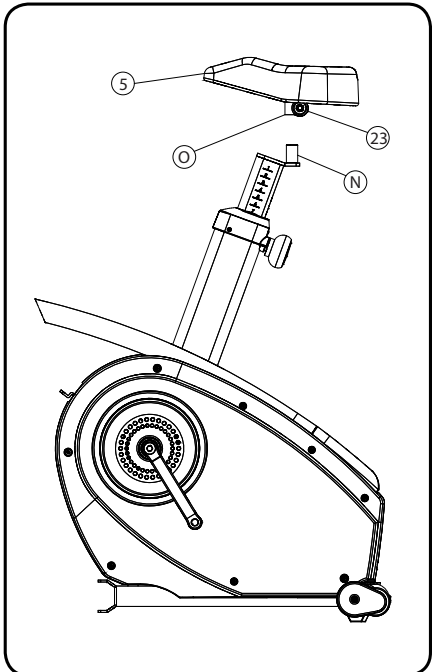

Assembling Your C3i Upright Bike

Step 5: Front Support Assembly

- A. Adjust the *Seat Post* so it is at the highest setting.
- B. Tilt the bike back until it is resting on the *Seat* and the *Rear Support Assembly* (as shown below.)
- C. Align the *Front Support Assembly (2)* with the *Front Main Frame Bracket (B)*.
- D. Install two *M8 Bolts (15)* and *Washers (16)* through the middle holes of the *Front Main Frame Bracket (B)* and into the *Front Support Assembly (2)*. **Do not tighten bolts yet.**
- E. Install two *M8 Bolts (15)* and *Washers (16)* through the top holes of the *Front Main Frame Bracket (B)* and into the *Front Support Assembly (2)*. **Do not tighten bolts yet.**
- F. Install two *M8 bolts (15)* and *Washers (16)* through the bottom holes of the *Front Main Frame Bracket (B)* and into the *Front Support Assembly (2)*. **Do not tighten bolts yet.**
- G. Securely tighten the two *M8 Middle Bolts (15)* first, then securely tighten the two *M8 Top Bolts* and two *M8 Bottom Bolts*.

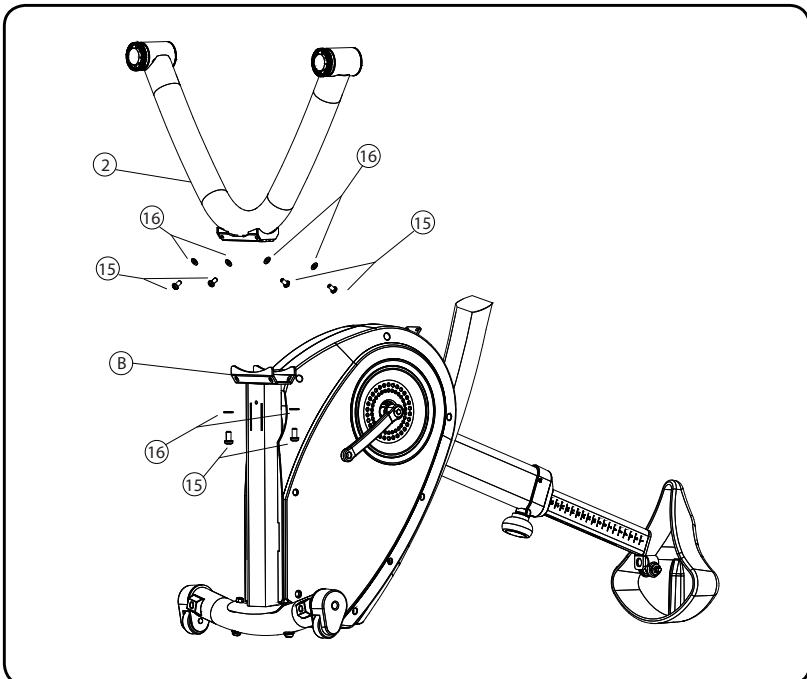

Assembling Your C3i Upright Bike

Step 6: Console Upright Assembly

- A. Align the *Console Mast (7)* with the *Upper (C)* and *Lower (D)* Console Mast Brackets.
- B. Connect the *Wire Connector (E)* coming from the Console Mast to the *Wire Connector (F)* coming from the *Lower Main Frame Bracket (D)* together and push the excess wire up inside the *Console Mast Tube (7)*.
- C. Slide the *Lower Console Mast Cover (6)* down off the Console Mast and slide it into the *Main Frame Covers (G)*.
- D. Place the bottom of the *Console Mast (7)* over the *Lower Bracket (D)* and into the *Lower Mast Cover (6)*.
- E. Install the two long *M8 Bolts (V)* through the *Console Mast (7)* and into the *Upper Console Mast Bracket (C)*. **Do not tighten bolts yet.**
- F. Install the two shorter *M8 Bolts (15)* and *Washers (16)* through the *Lower Console Mast Cover (6)* and *Console Mast (7)*, into the *Lower Console Mast Bracket (D)*. **Do not tighten bolts yet.**
- G. Securely tighten the two longer *M8 Bolts (19)* first, then the two shorter *M8 Bolts (15)*.

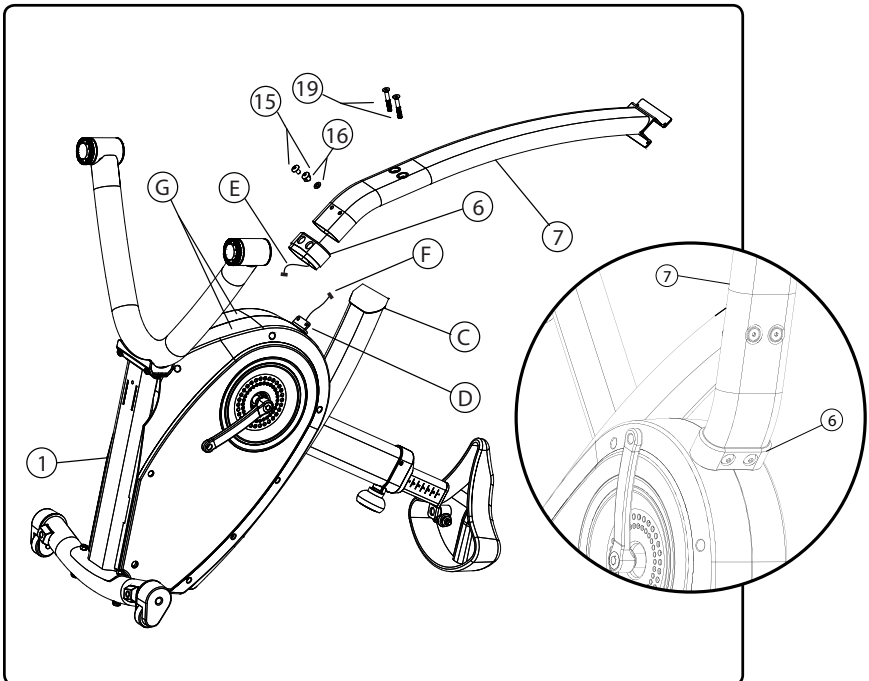

Assembling Your C3i Upright Bike

Step 7: Handlebar Assembly

- A. Place bike upright on all four feet.
- B. Align the *Handlebar Assembly (8)* with the *Handlebar Bracket (H)* on the *Console Mast (7)*.
- C. Feed the wire harness connector from the top of the *Console Mast (7)* through the square hole in the middle of the *Handlebar Assembly (8)*. There should be four wire connectors coming out the top of the *Handlebar Assembly*.
- D. Place the *Handlebar Assembly (8)* into the *Handlebar Bracket (H)* and align with bolt holes. Be sure to pull any slack wiring through the *Handlebar Assembly* so the wire harness does not get pinched.
- E. Install two *M8 Bolts (20)* through the *Handlebar Assembly (8)* into the *Handlebar Bracket (H)*.
- F. Securely tighten bolts.

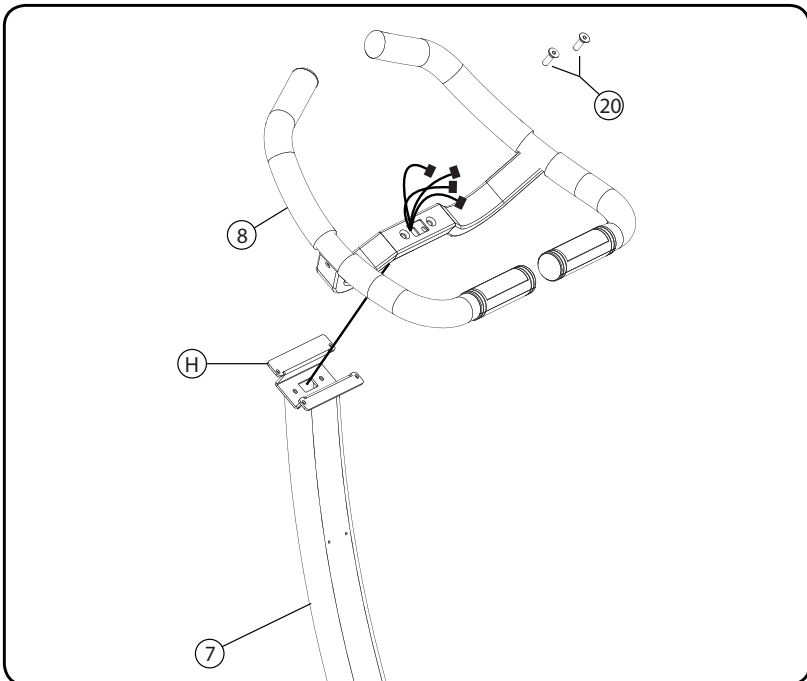

Assembling Your C3i Upright Bike

Step 8: Console Assembly

- A. Align the *Console (9)* with the *Console Mounting Bracket (K)*. Connect the two *2-pin Connectors (J)* coming from the *Console* to the two *2-pin Connectors (I)* coming from the *Handlebar Assembly (8)*. Push any excess wire into the opening in the back of the *Console (9)*.

NOTE: It does not matter which 2-pin connectors plug into each other as long as both connectors are plugged in.

- B. Connect the *Green Ground Connector* coming from the *Handlebar Assembly* to the *Green Wire* coming from the *Console*.
- C. Connect the remaining large connector directly into the corresponding white connector on the *Console Circuit Board (S)*.
- D. Place the *Console (9)* onto the *Console Mounting Bracket (K)*.
- E. Install four *M4 screws (21)* through the *Console Mounting Bracket (K)* and into the *Console (9)*. Once all four screws are installed securely tighten them.

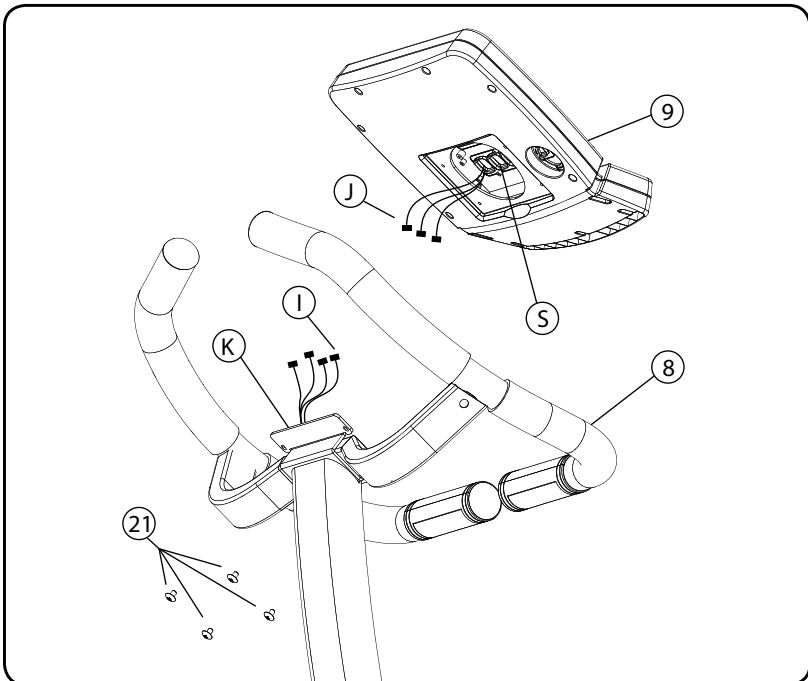

Assembling Your C3i Upright Bike

Step 9: Right and Left Pedal Assembly

- A. Identify which pedal goes on the right side and which goes on the left side by locating the "R" on the top of the *Right Pedal* (11) and the "L" on the top of the *Left Pedal* (12).
- B. Hand tighten the *Right Pedal* into the *Right Crank Arm* (R) by turning **clockwise**.
- C. Hand tighten the *Left Pedal* into the *Left Crank Arm* (Q) by turning **counter clockwise**. Be careful not to cross thread the threads.
- D. Tighten both pedals with the provided 15mm wrench (24).

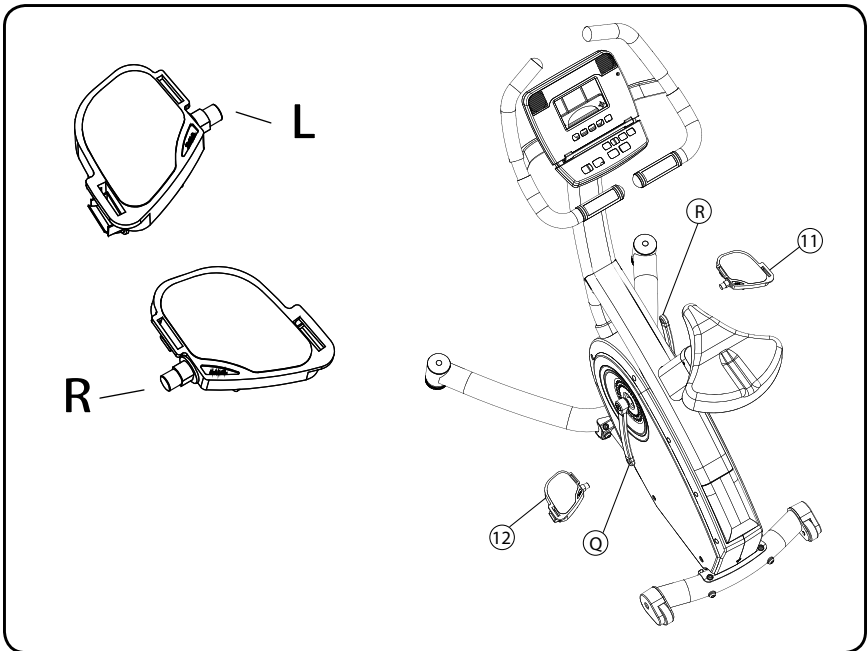

Assembling Your C3i Upright Bike

Step 10: Storage Tray Assembly

- A. Align the *Storage Tray (10)* with the holes in the *Console Mast (7)*.
- B. Remove the two #8 Screws (22) from the *Console Mast (7)*. Re-install the two #8 Screws through the *Storage Tray (10)* and into the *Console Mast* and securely tighten.

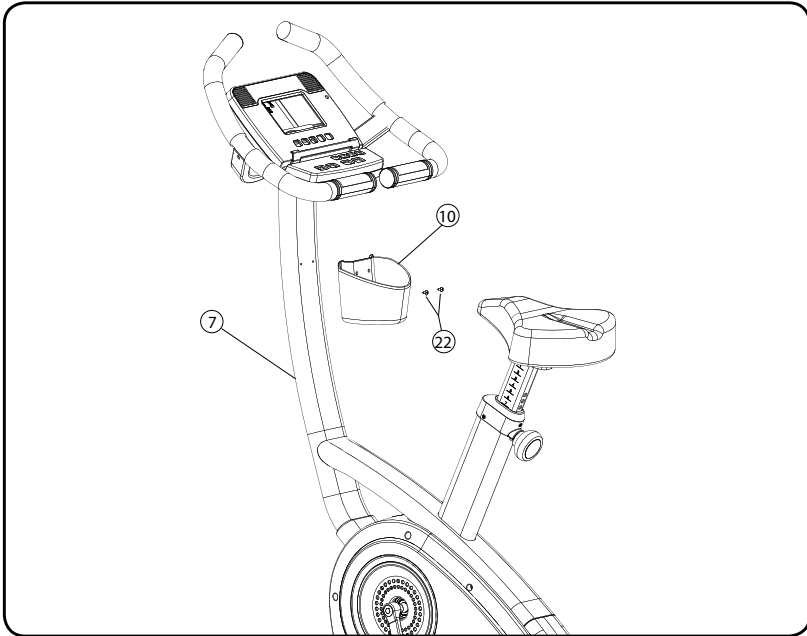

Step 11: Plug in the Power Supply

Step 12: Setting Date and Time

To set the date and time of day in your console follow these steps:

1. Press any of the quick level buttons for 3 seconds to initiate the date and time set up mode.
2. Press the ▲/▼ buttons to set the correct YEAR. Press **ENTER**.
3. Press the ▲/▼ buttons to select the correct MONTH. Press **ENTER**.
4. Press the ▲/▼ buttons to select the correct DAY. Press **ENTER**.
5. Press the ▲/▼ buttons to set the HOUR. Press **ENTER**.
6. Press the ▲/▼ buttons to set the MINUTES. Press **ENTER**.

Assembling Your C3i Upright Bike

Leveling

Your C3i bike comes with *Two Leveling Feet (P)* in the front and two *Stationary Feet (Q)* in the rear. Gently rock the bike back and forth to see if any of the feet are not sitting on the floor. Adjust the *Front Feet (P)* until all 4 feet are sitting on the floor.

HINT: If the left rear foot is not solid on the floor, turn the right front foot counterclockwise to tilt the left rear foot down to the floor.

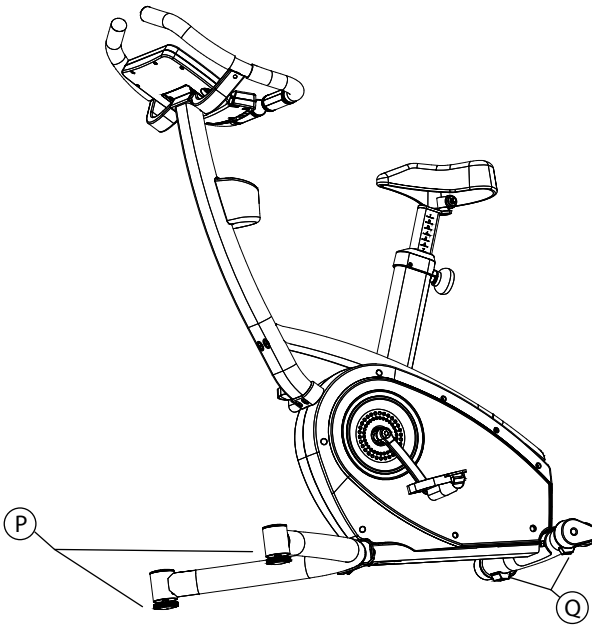

Assembling Your C3i Upright Bike

Seat Height Adjustments

Your C3i bike allows for 19 positions of height adjustment. To adjust the seat, pull the *Seat Post Adjustment Knob (M)* out and adjust the seat height to the desired position. Once the desired position is reached, release the *Seat Post Adjustment Knob*.

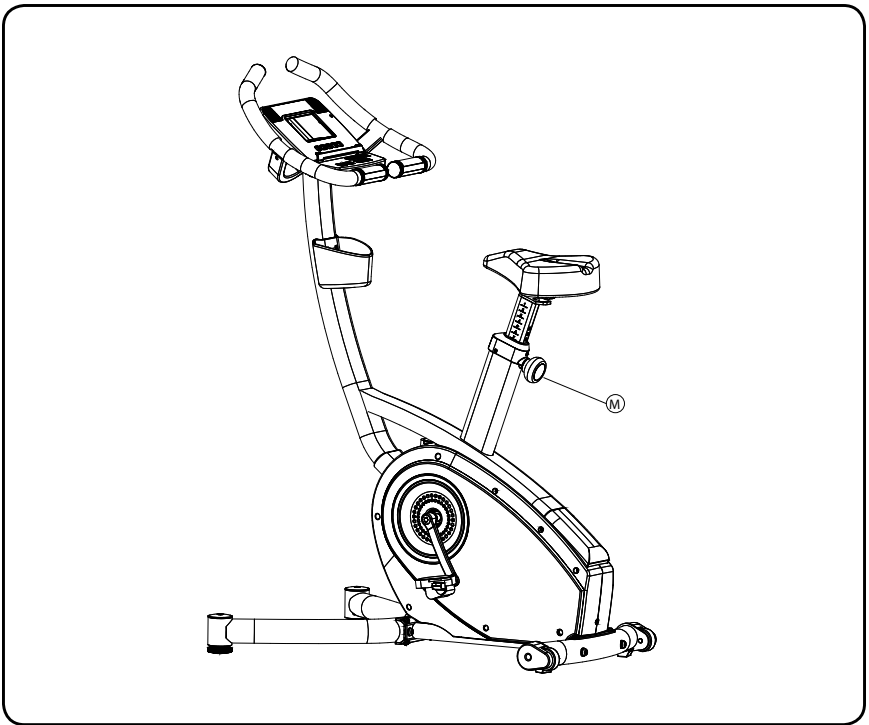

Display Console Overview



Console Buttons

The C3i comes with our innovative Intelli-Key feature that will prompt you through console operations by using intelligent lights on the buttons that automatically flash when they need to be pressed to continue operations.

A. Quickstart: - Press the START button to begin a Manual workout without having to set any individual information. When the program begins your workout time will start counting up from 00:00 and you can manually adjust the resistance using the ▲/▼ arrows.

A. Pause: -If you need to temporarily stop your workout, press the START button to PAUSE. To RESTART the workout, press the START button. After 10 minutes of no activity the console will reset.

A. Reset: - To RESET the console, press and hold the START button for 3 seconds.

B. Enter: - The ENTER button is used to select each piece of information needed during program setup, including Program, Workout Level, Workout Time, and Your Weight, which is used to more accurately calculate calories

burned. If you do not enter a Weight, the system will use a default weight of 150lbs to calculate calories burned.

C. Arrows: - These buttons are used to modify the value of each selection entered during the setup process and to change the workout resistance during use.

D. Program Buttons: - The C3i has Program Group buttons. These are designed to help you add variety to your exercise program while staying consistent with your exercise goals. To quickly select a specific program that matches your workout objective use one of the program buttons. These 5 buttons group the programs into Heart Rate Training, Healthy Living, Sports Training, Weight Loss and Custom User Programs. Depending on which button you select, there are multiple programs in each. To look at the next program within each group just press the Program Group button again to scroll to the next option.

E. Quick Resistance Buttons: - The C3i comes with 4 quick change resistance buttons allowing you to select resistance level 4, 8, 12, or 16 without scrolling. If you are using a preset program you can also use these buttons to adjust the entire profile of the program, making the program easier or more difficult to complete.

Setting the Date and Time

Before getting started using your C3i Upright Bike make sure the date and time are properly set on the console to ensure that your exercise data is properly recorded.

To set the date and time in your console follow these steps:

1. Press any of the quick level buttons for 3 seconds to initiate the date and time set up mode. Press **ENTER**.
2. Press the ▲ /▼ buttons to set the correct YEAR. Press **ENTER**.
3. Press the ▲ /▼ buttons to select the correct MONTH. Press **ENTER**.
4. Press the ▲ /▼ buttons to set the correct DAY. Press **ENTER**.
5. Press the ▲ /▼ buttons to set the correct HOUR. Press **ENTER**.
6. Press the ▲ /▼ buttons to set the correct MINUTES. Press **ENTER**.

Console Basics

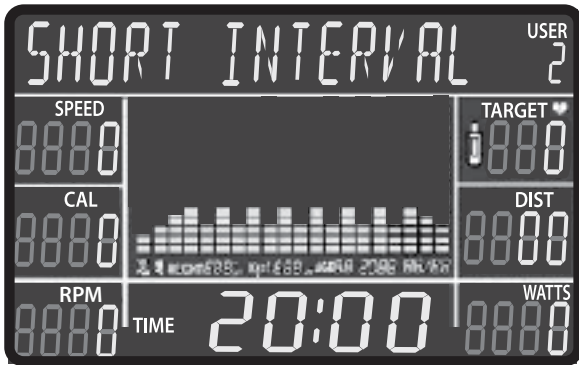

Display Console Window

Alpha Numeric Window - The C3i comes with a 16 character alpha window that is used to show the program name and set user functions like date and time.

Workout Feedback: The C3i display window will simultaneously display the following workout information:

Speed - The speed you are traveling in Miles Per Hour (this reading can be changed to Kilometer by using the Engineering Mode.)

Calories - Estimated calories burned since the beginning of the workout.

RPM - Number of Pedal Revolutions per minute.

Pulse- Your measured heart rate using the hand pulse sensors located on the handlebars.

Distance - Total distance traveled in miles or kilometers since the beginning of the workout

Time - The workout time elapsed or the workout time remaining.

Misc. Information Display- The C3i will also show the following information. This information will be used as part of the USB feature to save your workout information on the date and time of your workout.

Date - The date is presented as the year / month / day below the program matrix.

Time - The time of day is shown in the bottom center window when the console is not in use.

Name/Sex/Height/Weight/Age - Used with your Interactive Health Partner Account, when you insert your USB flash drive the console will read your name, sex, height, weight and age. Your name will appear in the alpha display at the top and your sex, height, weight, and age will appear below the program matrix.

This information is used to more accurately calculate calories.

QuickSTART

The quickest way to get started with a workout is to press the **START** button. This will start the upright bike in manual mode with the time counting up from 00:00. You can also set a desired workout Time and update your Weight in the console for more accurate calorie calculation by following these steps:

- A. Press **ENTER** to select manual mode.
- B. Select the amount of time (in minutes) you want to use the manual program by pressing the resistance ▲/▼ buttons. Press **ENTER**.
- C. Use the resistance ▲/▼ buttons to set your weight. Your weight is used to more accurately calculate calories burned. Press **ENTER**.
- D. Press **START** and the upright bike will start with the time counting down from the preset time.
- E. To increase resistance press the ▲ button.

Using Programs

Starting in Manual Mode

The quickest way to get started is to press the **START** button. Pressing the **START** button will select the Manual program and the **TIME** will start counting up from 00:00. You can also press **ENTER** to select the Manual program. Using the **ENTER** button will allow you to set a specific workout **TIME**, and set your **WEIGHT** for more accurate calorie calculation.

Starting a Preset Program

1. Select Program - Use the Program buttons to select your desired Exercise Program. Each program button has multiple programs that you can scroll through. Each time you press the program button you will move to the next program option. Once you find the desired program press **ENTER**.

You can also select programs by pressing the **▲/▼** arrows. Press **ENTER** when you find the program you want to use.

2. Set Program Level - There are 2 levels of intensity with each preset program (1 being the easiest and 2 being the most difficult).

3. Set Time – Set the program **TIME** of your workout using the **▲/▼** arrow keys. Press **ENTER**.

4. Set Weight – Set your **WEIGHT** in the console for more accurate calorie calculation using the **▲/▼** arrow keys. Press **ENTER**.

5. Press the **START** button to begin your workout.

Custom User Set-Up Programs

There are two user programs that provide you with the ability to build custom program profiles for your specific workout requirements. In Custom User Programs you set the workout time and then for each of the 20 program segments you set the resistance level. User programs need to be set-up before they can be used. To set up a user program:

1. **Select USER1 or USER2 Programs** - Use the ▲ /▼ arrow keys to select the USER1 OR USER2 programs. Press ENTER.
2. **Set Time** - Set the program TIME of your workout using the ▲ /▼ arrow keys. Press ENTER.
3. **Set Weight** – Set your WEIGHT in the console for more accurate calorie calculation using the ▲ /▼ arrow keys . Press ENTER
4. **Set Level** – Select the level for each segment in the exercise program. Press ENTER and repeat until all 20 segments are complete.
5. **START** - Press the START button.

Once the program has been set up, simply scroll to the USER1 or USER2 program and press START.

My Zone Heart Rate Control Programs

The C3i has 2 MyZone Heart Rate control programs: **Constant** and **Interval**. In each of these programs you will set your target heart rate and the console will automatically adjust the resistance to maintain your heart rate at either a CONSTANT level or at an alternating LOW and HIGH level. You will need to use the hand pulse sensor to receive your heart rate throughout the course of the workout. You can also purchase a chest strap for a wireless heart rate readout. Please review the Heart Rate Monitoring section of this Owner's Manual for more information.

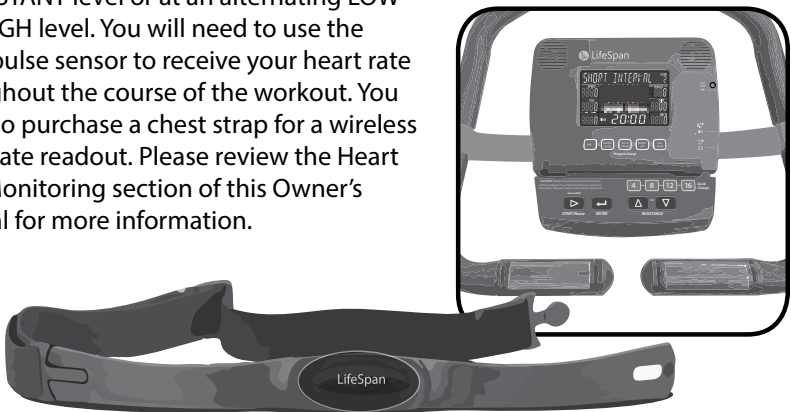

Using Programs

HRC1 – Constant Heart Rate Control

The Constant Heart Rate is a steady state program that lets you select a single heart rate to maintain throughout your workout. After 3 minutes of warm up, the pedaling resistance will automatically be adjusted every 10 seconds to get your heart rate up to the preset level that you selected and then maintain your heart rate during the workout. Refer to the Heart Rate Training section of this manual to determine your optimal training zones based on your age and exercise objectives.

To use this program:

1. **Select HRC1** - Use the ▲/▼ arrow keys to select the HRC1 program. Press the **ENTER** button to select.
2. **Set Time** - Set the program TIME using the ▲/▼ arrow keys. Press **ENTER**. Remember that the program will include 3 minutes of warm up and 3 minutes of cool down
3. **Set Weight** – Enter your weight using the ▲/▼ arrow keys. Press **ENTER**.
4. **Set Age** – Enter your age using the ▲/▼ arrow keys. Press **ENTER**.
5. **Set Target Heart Rate** – Set your target heart rate using the ▲/▼ arrow keys. Press **ENTER**.
6. Press the **START** button to begin your workout.

OPERATIONS

While exercising you can change the Resistance level by pressing the ▲/▼ buttons. To pause your exercise program press the **START** button and to reset your program, press the **START** button for 3 seconds.

HRC2 – Interval Heart Rate Control

The Interval program is designed to help you increase your aerobic endurance and improve heart rate recovery. This program lets you select a Low (or recover target heart rate) and a High target. After a 3-minute warm-up the console will adjust the Level every 10 seconds to maintain your Low target for 2 minutes. Then the console will adjust the Level to raise your heart rate to the High target that you selected and once again keep it at this level for 2 minutes and then repeat the process until the end of the workout. It is recommended that you set the workout time to 20 minutes or higher to use this program effectively.

To use this program:

1. **Select HRC2** - Use the ▲/▼ arrow keys to select the HRC2 program. Press the **ENTER** button to select.
2. **Set Time** - Set the program TIME using the ▲/▼ arrow keys. Press **ENTER**. Remember that the program will include 3 minutes of warm up and 3 minutes of cool down
3. **Set Weight** – Enter your weight using the ▲/▼ arrow keys. Press **ENTER**.
4. **Set Age** – Enter your age using the ▲/▼ arrow keys. Press **ENTER**.
5. **Set HIGH Target Heart Rate** – Set your HIGH internal training rate using the ▲/▼ arrow keys. Press **ENTER**.
6. **Set LOW Target Heart Rate** – Set your LOW internal training rate using the ▲/▼ arrow keys. Press **ENTER**.
7. Press the **START** button to begin your workout.



WARNING: Heart rate monitoring may be inaccurate. Over exercising may result in serious injury or death. If you feel faint stop exercising immediately.

Saving Your Results

Save your exercise results with the USB port built into your console and your own USB drive. Once Saved, use the LifeSpan Club to consolidate and compare all your results.

LifeSpan Club

Your bike includes a free membership to the LifeSpan Club. With this account you can consolidate all your exercise results in one place, track your weight and other metrics and get more information about your health and fitness. Go to www.lifespanfitness.com/apps/club/ to enroll.



Engineering Mode

To Enter Engineering Mode, Press and hold the Enter Button and the Up button for 3 seconds. The console will beep and display Engineering Mode.

Function	Display
Press Enter. The display will show Select the units. Press the ▲ or ▼ buttons to change between Si (metric) or EN English modes.	Select the units SI or EN
Press Enter. The display will show Set calendar On or Off. Use the ▲ or ▼ buttons to change between On or Off	Set Calendar On/Off
Press Enter. The display will show Electricity On or Off. To set the console to go into sleep mode set Electricity to On. For the console to be lit at all times set it to Off.	Electricity On/Off
Press Enter. The display will show Total Distance. It will show 1 digit on the left and 3 digits on the right for a total of 4 digits. This is the total number or miles or Kilometers accumulated.	Total Distance 0 000
Press Enter. The display will show Total Hours. It will show 1 digit on the left and 3 digits on the right for a total of 4 digits. This is the total number of hours the bike has been used.	Total Hours 0 000
Press Enter	Console goes back to normal operating mode

Maintenance and Tips

Troubleshooting

If you have a question that isn't answered in this Owner's Manual, visit our website at www.LifeSpanFitness.com or call us at 877.654.3837 option 4.

Problem: Unit is unstable or rocks while in use.

Solution: Make sure unit is on a solid, level surface. Adjust the front adjustment feet until all 4 feet are sitting solid on the floor.

Problem: No power at console.

Solution: Try using another outlet or testing something else at the outlet being used to make sure there is power at the outlet. If still a problem contact Lifespan Customer Service.

Problem: Rough feeling in pedals when in use.

Solution: If everything is tight, contact LifeSpan Customer Service for replacement pedals.

Problem: Excess play in the handlebars or frame components.

Solution: Using the provided assembly tools, go over the C3i to make sure all assembly hardware is tight.

General Maintenance

1. Keep the upright bike clean and dry. It is a good idea to wipe the upright bike down after each workout.
2. If the unit is not going to be used for any extended period of time it is a good idea to unplug the unit and store in a clean environment.
3. Clean only with mild soap and a slightly damp cloth. Never use solvents when cleaning.

Moving the C3i Upright Bike

Your C3i bike is equipped with two transport wheels (R) located on the rear support. Carefully tilt the front of the bike up until the transport wheels in the back make contact with the floor and roll the bike to the desired location. It may be difficult to roll the bike in plush carpeting.



 **CAUTION:** When lifting, use proper safety precautions and lifting techniques. Bend your knees and elbows, keep your back straight and pull up evenly with both arms.

C3i

Upright Bike Interactive Trainer

LifeSpan Fitness

P.O. Box 981316

Park City, Utah 84098-1316

Phone: 877.654.3837

www.LifeSpanFitness.com

Version 1.2