

# KENWOOD

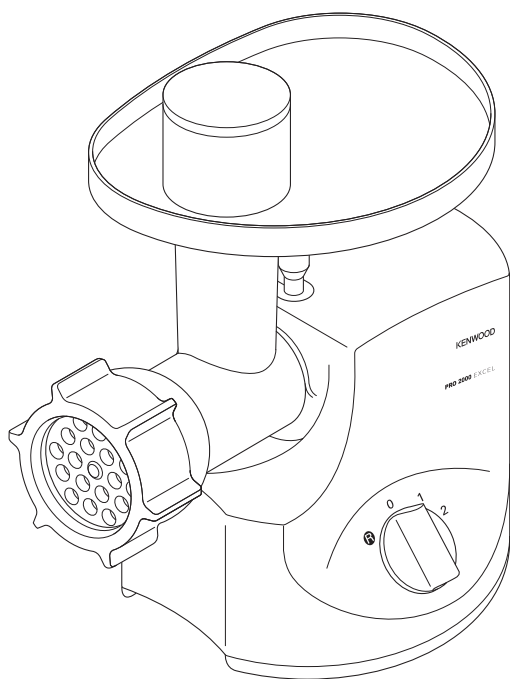

MG700 series

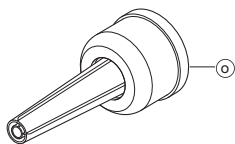

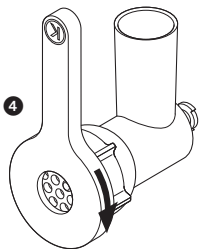
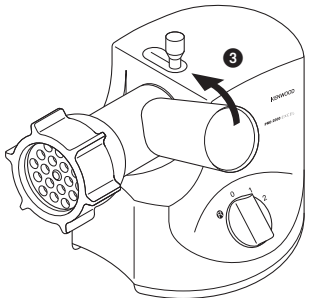
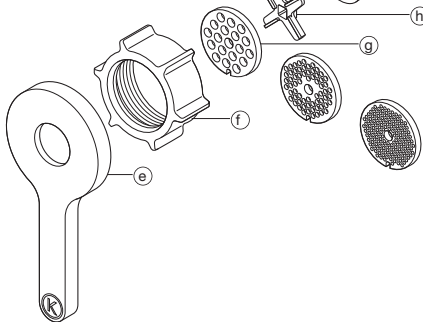
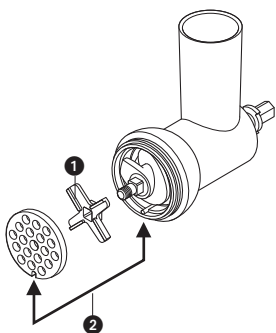
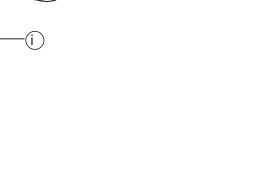
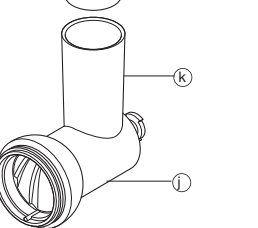
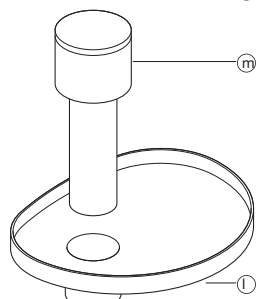
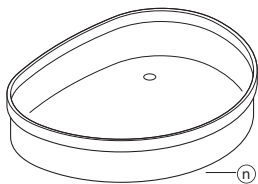
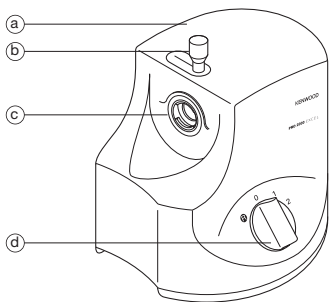
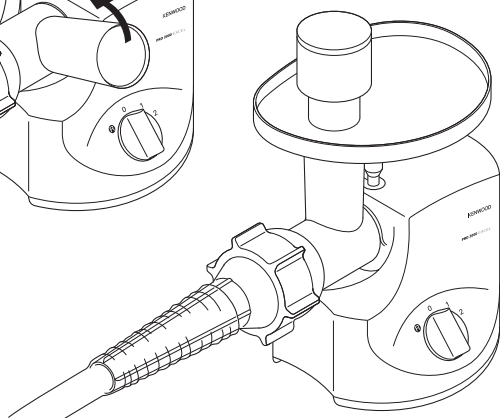
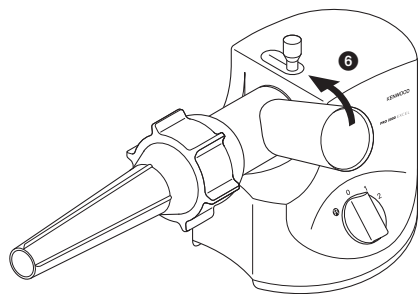
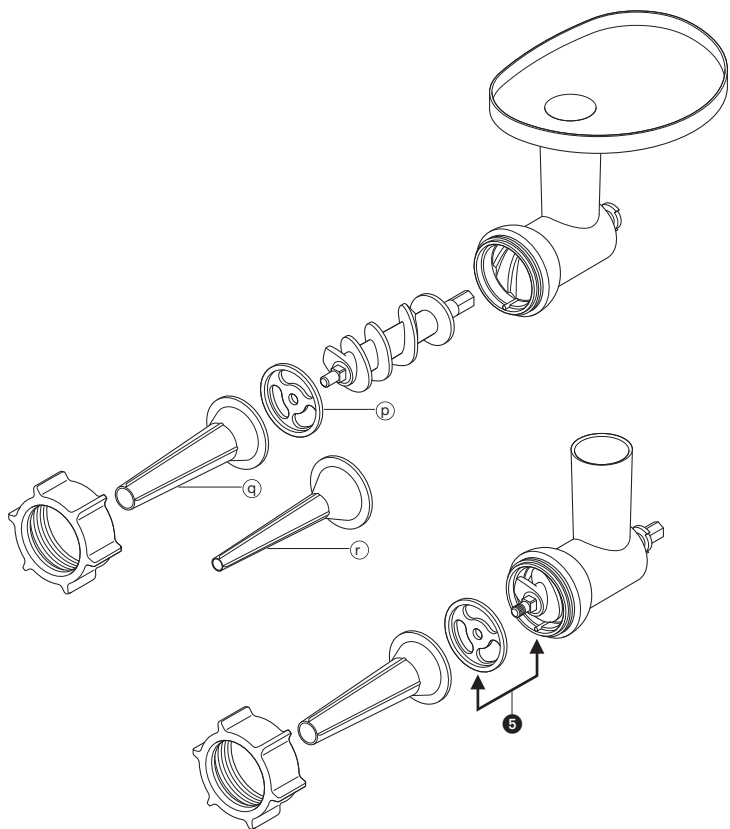

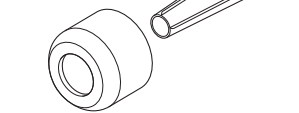
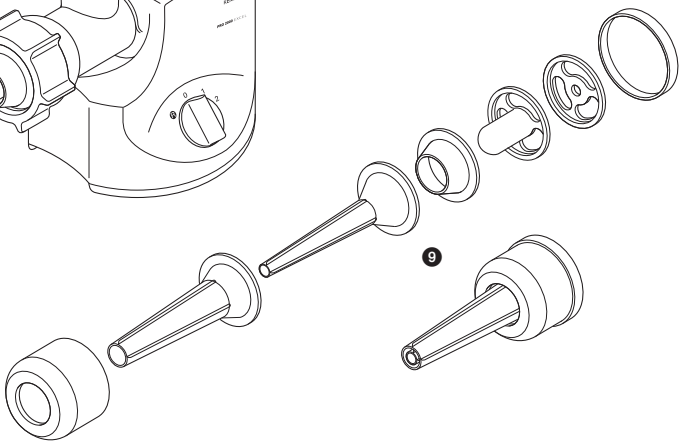
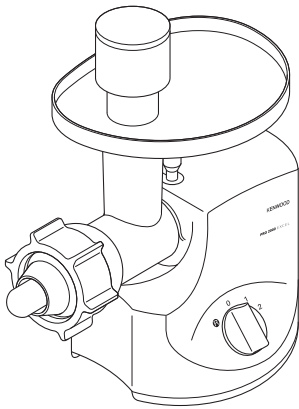
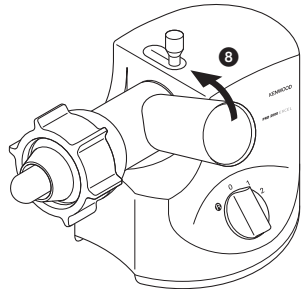
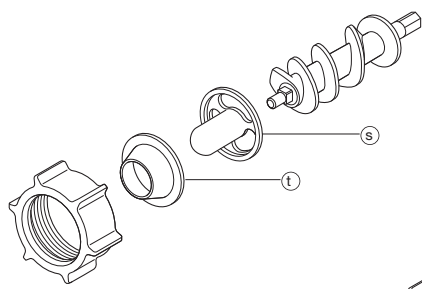
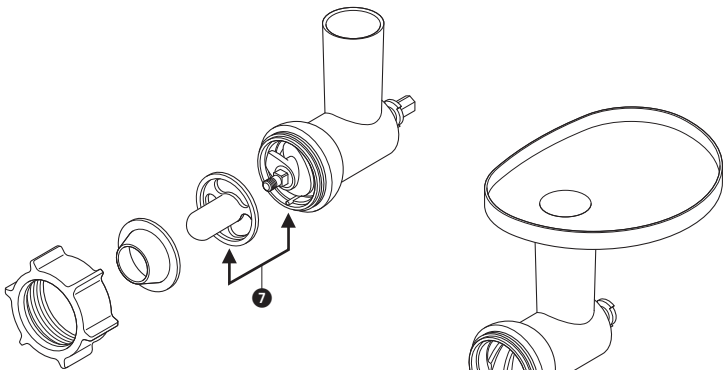

Use the meat grinder to process meat, poultry and fish. Use the inclusive attachments to shape sausages and kebbe.

## **before using your Kenwood appliance**

- Read these instructions carefully and retain for future reference.
- Remove all packaging and any labels.

## **safety**

- Always ensure bones and rind etc are removed from the meat before mincing.
- When mincing nuts only feed a few down at a time and allow the scroll to pick them up before adding any more.
- Always unplug:
  - before fitting or removing parts
  - after use
  - before cleaning.
- Always use the pusher supplied. Never put your fingers or utensils in the feed tube.
- Warning - the cutting blade is sharp, handle with care both in use and cleaning.
- Ensure the attachment is secured in position before switching on.
- To avoid electric shocks, never let the power unit, cord or plug get wet.
- Never use a damaged appliance. Get it checked or repaired: see 'Service'.
- Never use an unauthorised attachment.
- Never let the cord hang down where a child could grab it.
- This appliance is not intended for use by persons (including children) with reduced physical, sensory or mental capabilities, or lack of experience and knowledge, unless they have been given supervision or instruction concerning use of the appliance by a person responsible for their safety.

- Children should be supervised to ensure that they do not play with the appliance.
- Only use the appliance for its intended domestic use. Kenwood will not accept any liability if the appliance is subject to improper use, or failure to comply with these instructions.

## **before plugging in**

- Make sure your electricity supply is the same as the one shown on the underside of your machine.

## **important (UK) only**

- The wires in the cord are coloured as follows:  
Blue = Neutral  
Brown = Live.
- The appliance must be protected by a 13A approved (BS1362) fuse.

## **Note:**

- For non-rewireable plugs the fuse cover **MUST** be refitted when replacing the fuse. If the fuse cover is lost then the plug must not be used until a replacement can be obtained. The correct fuse cover is identified by colour and a replacement may be obtained from your Kenwood Authorised Repairer (see Service).
- If a non-rewireable plug is cut off it must be **DESTROYED IMMEDIATELY**. An electric shock hazard may arise if an unwanted non-rewireable plug is inadvertently inserted into a 13A socket outlet.
- This appliance conforms to EC directive 2004/108/EC on Electromagnetic Compatibility and EC regulation no. 1935/2004 of 27/10/2004 on materials intended for contact with food.

## **before using for the first time**

- 1 Wash the parts see 'care and cleaning'
- 2 Push excess cord into the cord stowage compartment at the back of the power unit.

## mincer

- (a) power unit
- (b) locking lever
- (c) attachment outlet
- (d) on/off speed control
- (e) spanner
- (f) ring nut
- (g) mincer screens: fine, medium, coarse
- (h) cutter
- (i) scroll
- (j) mincer body
- (k) feed tube
- (l) tray
- (m) pusher
- (n) dish/cover
- (o) storage unit for kebbe and sausage adaptors

## to assemble

- 1 Fit the scroll inside the mincer body.
- 2 Fit the cutter – cutting side outermost **1. Ensure it's seated properly – otherwise you could damage your mincer.**
- 3 Fit a mincer screen **2**. Put the notch over the pin.
  - Use the fine screen for raw meat; fish; small nuts; or cooked meat for shepherd's pie or meat loaves.
  - Use the medium and coarse screens for raw meat; fish and nuts.
- 4 Loosely fit the ring nut.

## to use the mincer

- 1 With the mincer attachment in the position shown **3**, locate in the outlet. Rotate the mincer body so that the feed tube is upright.
- 2 Tighten the ring nut firmly by hand.
  - If you experience poor results when mincing meat, switch off and unplug the machine. Dismantle and clean the attachment, then re-assemble the attachment and refit to the power unit. Tighten the ring nut using the spanner provided **4**.

- 3 Fit the tray. Put the dish/cover under the mincer to catch the food.
- 4 **Thaw frozen food thoroughly before mincing.** Cut meat into 2.5cm (1") -wide strips.
- 5 Switch to speed 2. Using the pusher, gently push the food down the feed tube, one piece at a time. **Don't push hard – you could damage your mincer.**

Note:

Speed 1 is for extruding sausages, kebbe and for use with the optional attachments.

- If the machine stalls or overheats during use, it will stop mincing and emit a quiet humming noise. In the case of a stall, switch the machine off, then turn the control to R (reverse) for a few seconds to release the clogged food. Switch off and unplug the machine and remove any clogged material. However, if the machine overheats, switch the machine off and allow it to cool down for 1 hour before continuing the mincing operation.
  - When selecting reverse, always wait until the machine stops operating before turning the speed control to the reverse (R) position.
- 6 Switch off and unplug after use.
  - 7 Loosen the ring nut. If necessary use the spanner provided.
  - 8 Move the locking lever towards the back of the unit, then rotate the feed tube towards the front of the machine, then pull free.

## sausage filler

- (p) base plate
- (q) large nozzle (for thick sausages)
- (r) small nozzle (for thin sausages)

Ask your butcher for sausage skin or mail order from the Natural Casing Company Ltd, PO Box 133, Farnham, Surrey GU10 5HT, England. Use pig/hog skin on the large nozzle and sheep/lamb skin on the small nozzle. Or, instead of using skin, roll in breadcrumbs or seasoned flour before cooking.

## to use the sausage filler

- 1 If you're using skin, soak it in cold water for 30 minutes first. Then open it up with a jet of water and place your chosen nozzle under a running tap and pull the skin onto the nozzle.
- 2 Fit the scroll inside the mincer body.
- 3 Fit the base plate **5** - put the notch over the pin.
- 4 Hold the nozzle on the mincer attachment and loosely screw the ring nut on.
- 5 With the mincer attachment in the position shown **6**, locate in the outlet. Rotate the mincer body so that the feed tube is upright.
- 6 Tighten the ring nut firmly by hand.
- 7 Fit the tray.
- 8 Switch on to speed 1. Using the pusher, push the food down the feed tube. **Don't push hard – you could damage your mincer.** Ease the skin off the nozzle as it fills. Don't overfill.
- 9 Twist the skin to form sausages.

## pork sausage recipe

- 100g (4oz) dry bread
- 600g (1½lb) pork, lean and fat, cut into strips
- 1 egg, beaten
- 5ml (1tsp) mixed herbs
- salt and pepper

- 1 Soak the bread in water, then squeeze and discard the water.
- 2 Mince the pork into a bowl.
- 3 Add the remaining ingredients and mix well.
- 4 Make into sausages (see 'to use the sausage filler').
- 5 Fry, grill or bake until golden brown.

## kebbe maker

- (s) shaper
- (t) cone

Kebbe is a traditional Middle Eastern dish: deep-fried lamb-and-bulgur-wheat parcels with a minced meat filling.

## to use the kebbe maker

- 1 Fit the scroll inside the mincer body.
- 2 Fit the shaper **7** – put the notch over the pin.
- 3 Fit the cone.
- 4 Loosely screw the ring nut on.
- 5 With the mincer in the position shown **8**, locate in the outlet. Rotate the mincer body so that the feed tube is upright.
- 6 Tighten the ring nut firmly by hand.
- 7 Fit the tray.
- 8 Switch on to speed 1. Using the pusher, gently push your mixture through. Cut into lengths.

## stuffed kebbe recipe

### outer casing

500g (1lb 2oz) lamb or fat-free mutton, cut into strips

500g (1lb 2oz) bulgur wheat, washed and drained

1 small onion, finely chopped

### Important

Always use the bulgur wheat straight away after draining. If it is allowed to dry out, it may increase the load on the mincer resulting in damage.

- 1 Using the fine screen, mince alternate batches of meat and wheat.
- 2 Mix. Then mince twice more.
- 3 Stir the onion into the mix.
- 4 Push through, using the kebbe maker.

### Filling

400g (10oz) lamb, cut into strips

15ml (1tbsp) oil

2 medium onions, finely chopped

5-10ml (1-2tsp) ground allspice

15ml (1tbsp) plain flour  
salt and pepper

- 1 Using the fine screen, mince the lamb.
- 2 Fry the onions until golden brown. Add the lamb.
- 3 Add the remaining ingredients and cook for 1-2 minutes.
- 4 Drain off any excess fat and allow to cool.

### To finish

- 1 Push the casing mixture through, using the kebbe maker.
- 2 Cut into 8cm (3") lengths.
- 3 Pinch one end of the tube to seal it. Push some filling – not too much – into the other end, then seal.
- 4 Deep fry in hot (190°) oil for about 6 minutes or until golden brown.

## care and cleaning

- Always switch off and unplug before cleaning.

### power unit

- Wipe with a damp cloth, then dry.
- Never immerse in water or use abrasives.

### mincer attachment

- 1 Loosen the ring nut manually or with the spanner **4** and dismantle. Wash all the parts in hot soapy water, then dry. **Don't wash any part in the dishwasher.** Never use a soda solution.
- 2 Re-assemble.
- 3 Wipe the screens with vegetable oil, then wrap in greaseproof paper to prevent discolouring/rusting.
- 4 If you keep the mincer on the machine, put the dish/cover on the tray as a dust-cover.
- 5 The sausage and kebbe attachments can be kept together in the storage unit supplied **9**.

## service and customer care

- If the cord is damaged it must, for safety reasons, be replaced by Kenwood or an authorised Kenwood repairer.

### UK

If you need help with:

- using your machine or
  - servicing, spare parts or repairs (in or out of guarantee)
- ☎ call Kenwood customer care on 023 9239 2333. Have your model number ready** – it's on the underside of the power unit.
- **spares and attachments**
- ☎ call 0870 2413653.**

### other countries

Contact the shop where you bought your machine.



- Designed and engineered by Kenwood in the UK.
- Made in China.



### **guarantee**

If your mincer goes wrong within one year from the date you bought it, we will repair it (or replace it if necessary) free of charge provided:

- you have not misused, neglected or damaged it;
- it has not been modified (unless by Kenwood);
- it is not second-hand;
- it has not been used commercially;
- you have not fitted a plug incorrectly; and
- **you supply your receipt to show when you bought it.**

This guarantee does not affect your statutory rights.

### **IMPORTANT INFORMATION FOR CORRECT DISPOSAL OF THE PRODUCT IN ACCORDANCE WITH EC DIRECTIVE 2002/96/EC.**

At the end of its working life, the product must not be disposed of as urban waste.

It must be taken to a special local authority differentiated waste collection centre or to a dealer providing this service.

Disposing of a household appliance separately avoids possible negative consequences for the environment and health deriving from inappropriate disposal and enables the constituent materials to be recovered to obtain significant savings in energy and resources. As a reminder of the need to dispose of household appliances separately, the product is marked with a crossed-out wheeled dustbin.



Head Office Address:

Kenwood Limited, New Lane, Havant, Hampshire PO9 2NH, UK

[www.kenwoodworld.com](http://www.kenwoodworld.com)

Designed and engineered by Kenwood in the UK

Made in China

19615/1