

sharkoon

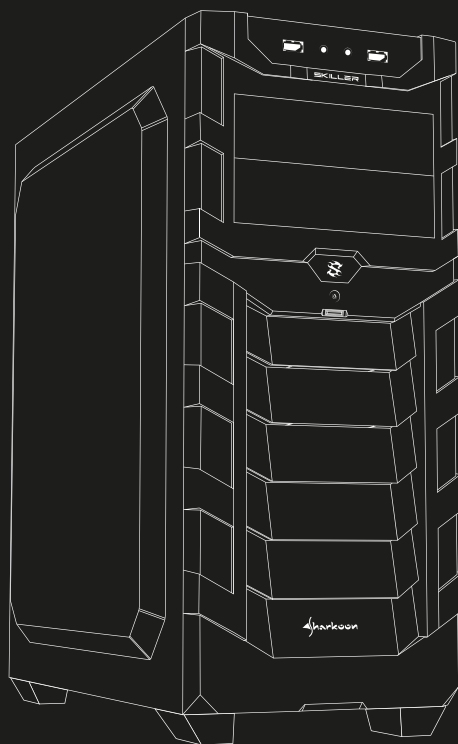

# SKILLER SGC1

Manual • Anleitung • Manuel • Manuale dell'utente • Handleiding  
Instrukcja • Használati útmutató • Manuál • 使用説明 • マニュアル

# Specifications

- Spezifikationen
- Spécifications
- Specifiche tecniche
- Especificaciones
- Especificações
- Specificaties

- Specifikacija
- Műszaki adatok
- Specifikace
- Technické údaje
- 規格
- 仕様

## General:

	Skiller SGC1	Skiller SGC1 Window
■ Form Factor	ATX	ATX
■ Expansion Slots	7	7
■ Interior Painting	✓	✓
■ Tool-Free Devices Installation	✓	✓
■ Cable Management System	✓	✓
■ Side Panel	Metal	Acrylic
■ Color Versions	Black	Red, Green, Blue, Black
■ Dimensions (L x W x H)	45.0 x 22.1 x 47.8 cm	45.0 x 22.1 x 47.8 cm

## I/O:

■ USB 3.0 (Front)	2	2
■ Audio (Front)	✓	✓

## Drive Bays:

■ 5.25"	1	1
■ 5.25" or 3.5"	1	1
■ 5.25" to 3.5" Bay Cover	1	1
■ 3.5" or 2.5"	2	2
■ 2.5"	2	2

## Fan Configuration:

■ Front Panel	1x 120 mm Fan (Pre-Installed) or Radiator (Optional)	1x 120 mm Fan (Pre-Installed) or Radiator (Optional)
■ Rear Panel	1x 120 mm Fan (Pre-Installed)	1x 120 mm LED Fan (Pre-Installed)
■ Side Panel	2x 120 mm Fan (Optional)	
■ Top Panel		3x 120 mm or 2x 140 mm Fans (Optional)

## Compatibility:

■ Mainboard	Mini-ITX, Micro-ATX, ATX	Mini-ITX, Micro-ATX, ATX
■ Max. Length Graphics Cards	40.0 cm	40.0 cm
■ Max. Height CPU Cooler	16.5 cm	16.5 cm
■ Max. Length Power Supply	24.0 cm	24.0 cm
■ Max. Height Radiator incl. Fan (Front)	5.9 cm	5.9 cm
■ Max. Height Radiator incl. Fan (Top)		5.0 cm

## Package Contents:

- |   |
|---|
| ■ Skiller SGC1/Skiller SGC1 Window, Accessory Set |
|---|

## 5.25" Device Installation

- Einbau 5,25"-Laufwerk
- 5,25" Installation de périphériques
- 5,25" Installazione dispositivo
- 5,25" Instalación de un dispositivo
- 5,25" Instalação de dispositivo
- Installatie 5,25" apparaat

- 5,25" Instalacja napędu
- 5,25" eszköz beszerelhetőség
- Instalace 5,25" jednotky
- Instalácia 5,25" zariadenia
- 5.25" 装置安裝
- 5.25" デバイスの取付け

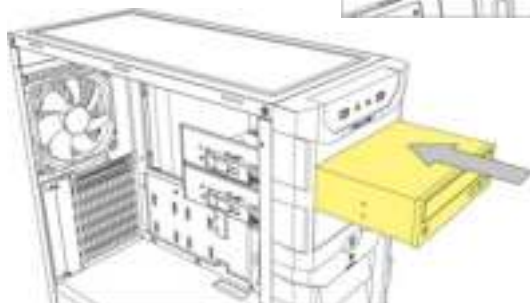

## 3.5" External Device Installation

- Einbau 3,5"-Laufwerk (Extern)
- 3,5" Installation de périphérique externe
- 3,5" Installazione dispositivo esterno
- 3,5" Instalación de un dispositivo externo
- 3,5" Instalação de dispositivo externo
- Installatie 3,5" apparaat (extern)

- 3,5" Zewnętrzne urządzenie Instalacja
- 3,5" külső eszköz beszerelhetőség
- Instalace externí 3,5" jednotky
- Instalácia externého 3,5" zariadenia
- 3.5" 外接装置安裝
- 3.5" 外付けデバイスの取付け

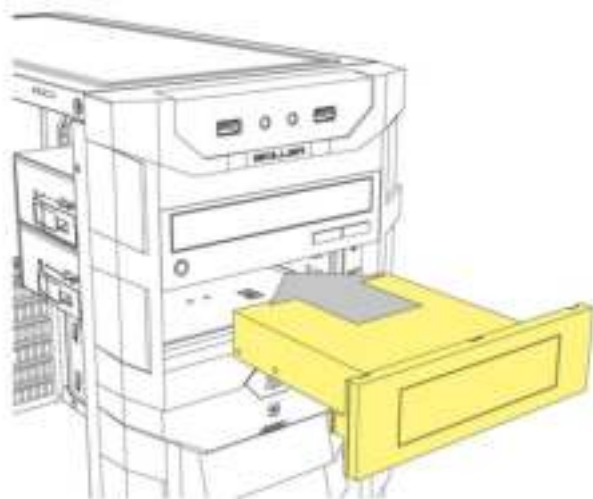
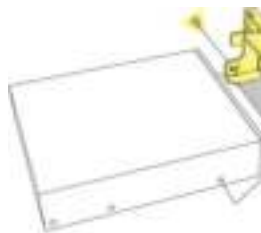

# 3.5" HDD Installation

- Einbau 3,5"-HDD
- 3,5" Installation HDD
- 3,5" Installazione disco fisso
- 3,5" Instalación HDD
- 3,5" Instalação HDD
- Installatie 3,5" HDD
- Instalacja dysku 3.5"
- 3,5" HDD beszerelhetőség
- Instalace 3,5" HDD
- Instalacia 3,5" HDD
- 3.5" 硬碟安裝
- 3.5" ハードディスクの取付け

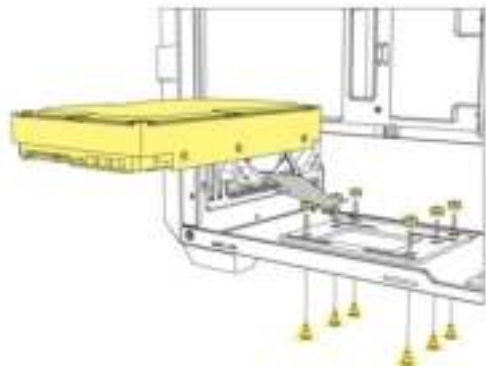
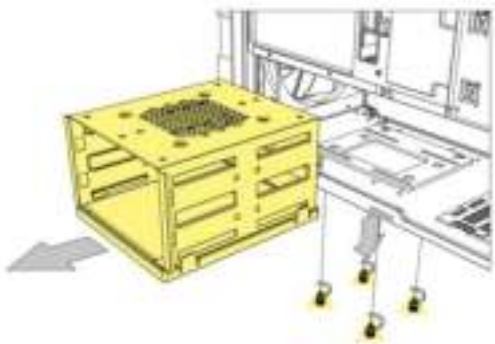
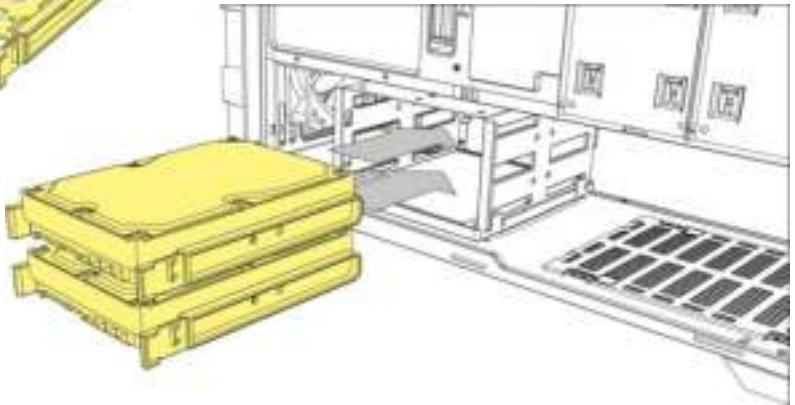
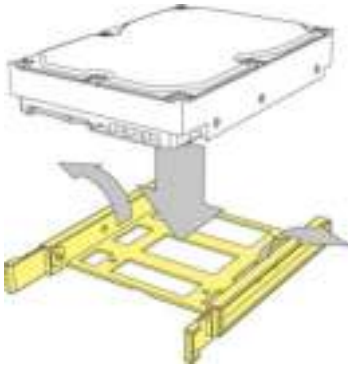

# 2.5" HDD/SSD Installation

- Einbau 2,5"-HDD/SSD
- 2,5" HDD/SSD Installation
- 2,5" Installazione disco fisso/unità SSD
- 2,5" HDD/SSD de instalación
- 2,5" Instalação HDD/SSD
- Installatie 2,5" HDD/SSD

- Instalacja dysku 2.5" SSD/HDD
- 2,5" HDD/SSD beszerelhetőség
- Instalace 2,5" HDD/SSD
- Instalacia 2,5" HDD/SSD
- 2.5" 硬碟/SSD 安裝
- 2.5" HDD/SSD の取付け

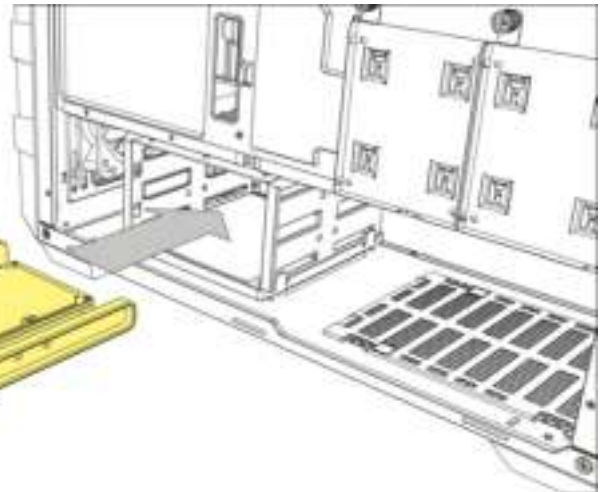
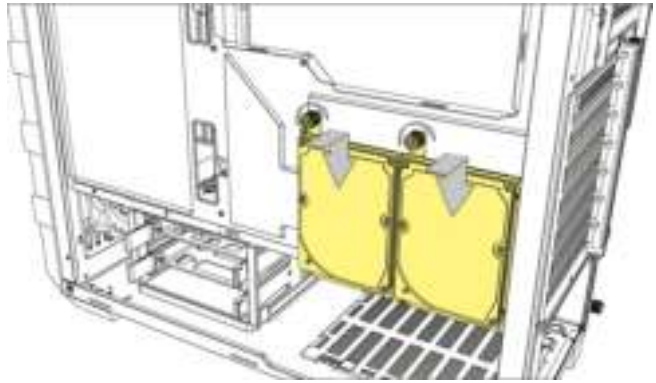
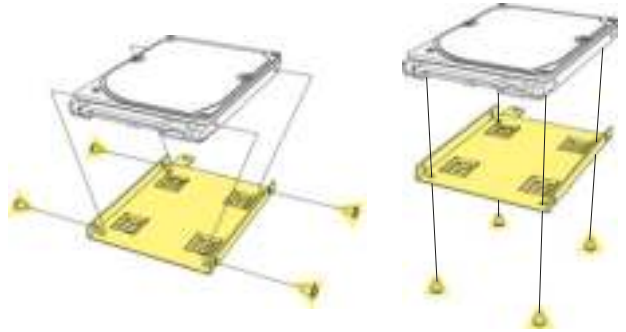
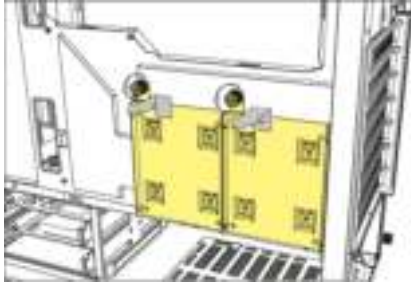

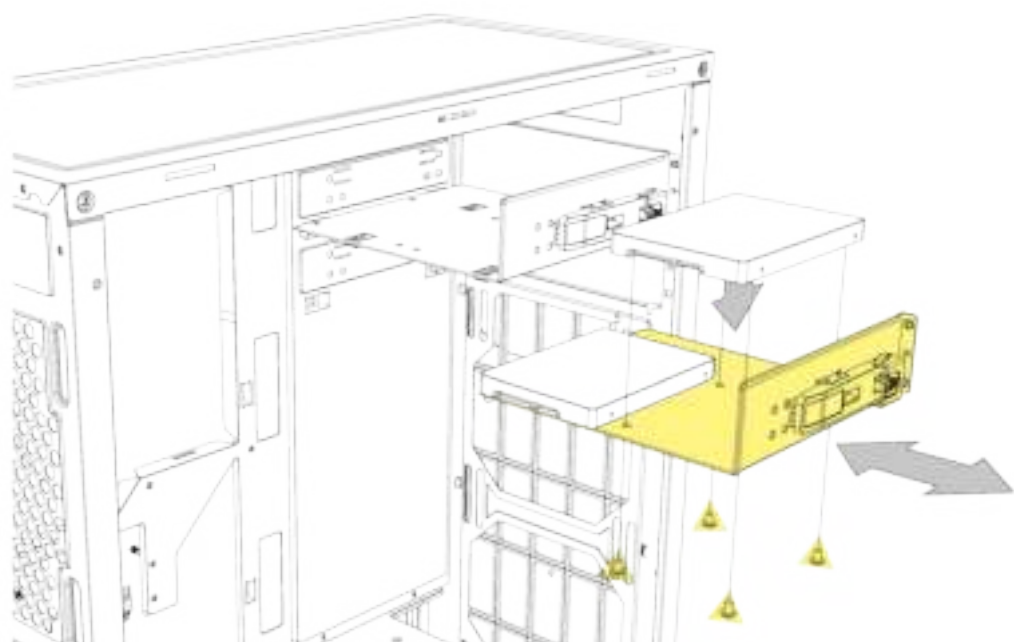
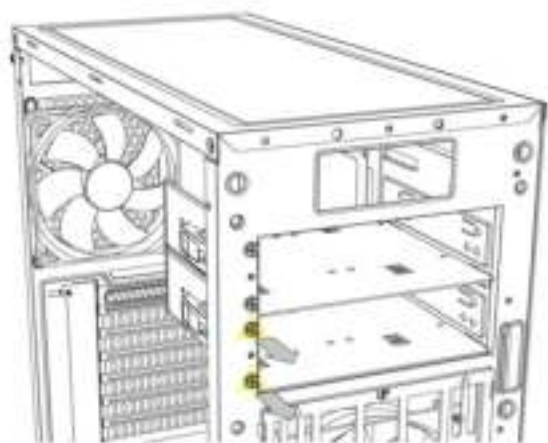

# Add-On Cards Installation

- Einbau Erweiterungskarten
- Add-On de cartes Installation
- Installazione Add-On Cards
- Tarjetas adicionales de instalación
- Instalação Add-On Cartões
- Installatie uitbreidingskaarten

- Instalacija kart rozszerzeń
- Bővítőkártya beszerelhetőség
- Instalace karet na základní desku
- Inštalácia kariet na základovú dosku
- 介面卡安裝
- 増設カードの取付け

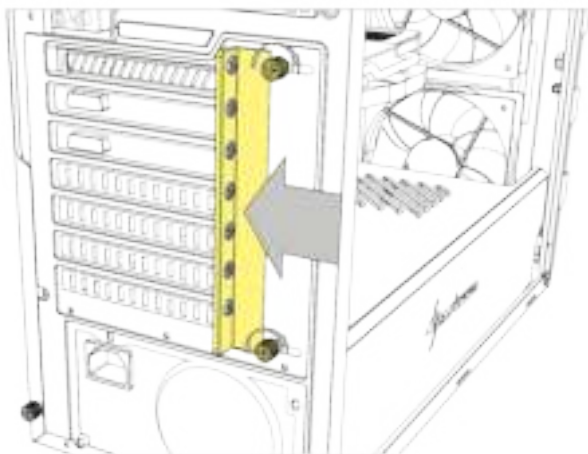
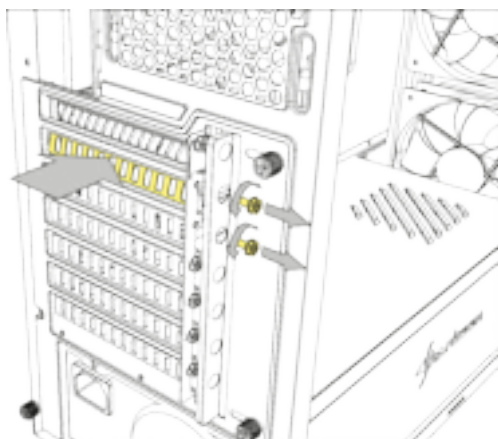
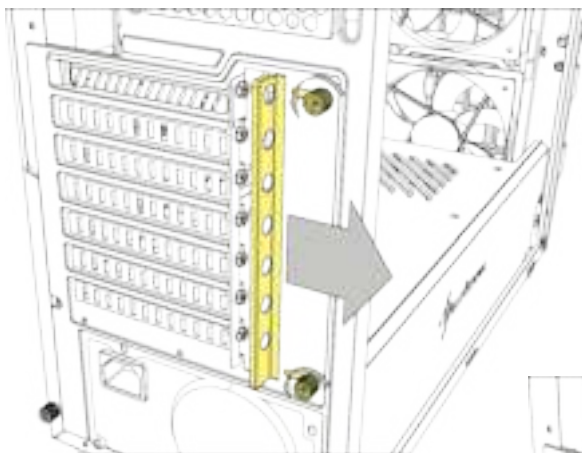



## Detachable Dust Filter

- Herausnehmbarer Staubfilter
- Amovibile filtru anti-poussièrè
- Filtro antipolvere staccabile
- Filtro de polvo desmontable
- Filtro de poeira destacável
- Afneembaar stoffilter
- Zdemowalny filtr przeciwkurzowy
- Levehető porszűrő
- Oddíltelný prachový filter
- Odnímateľný prachový filter
- 可拆卸式防塵濾網
- 着脱式ダストフィルター

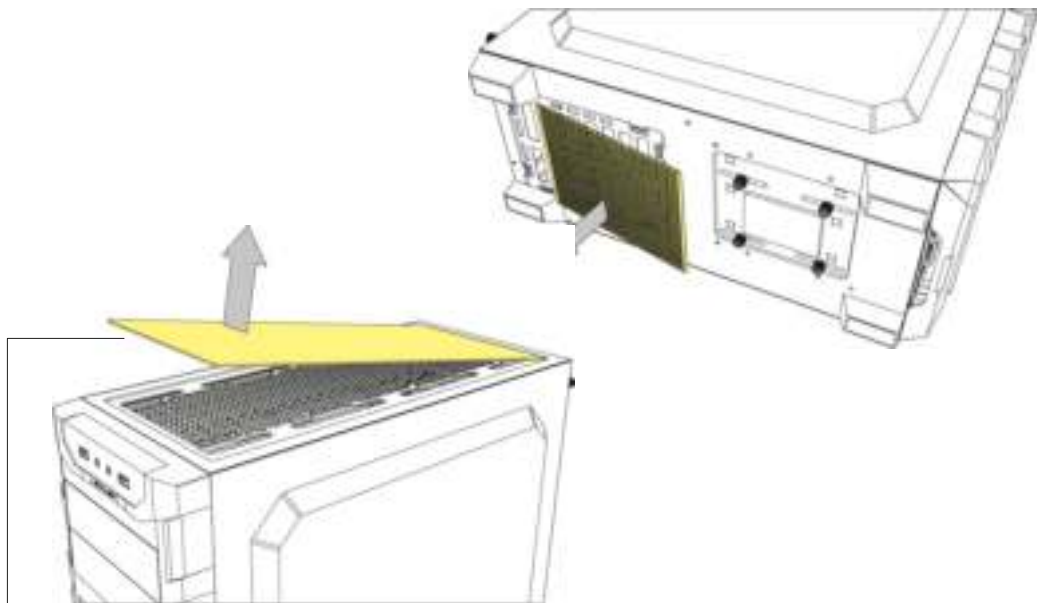

**For window edition only**

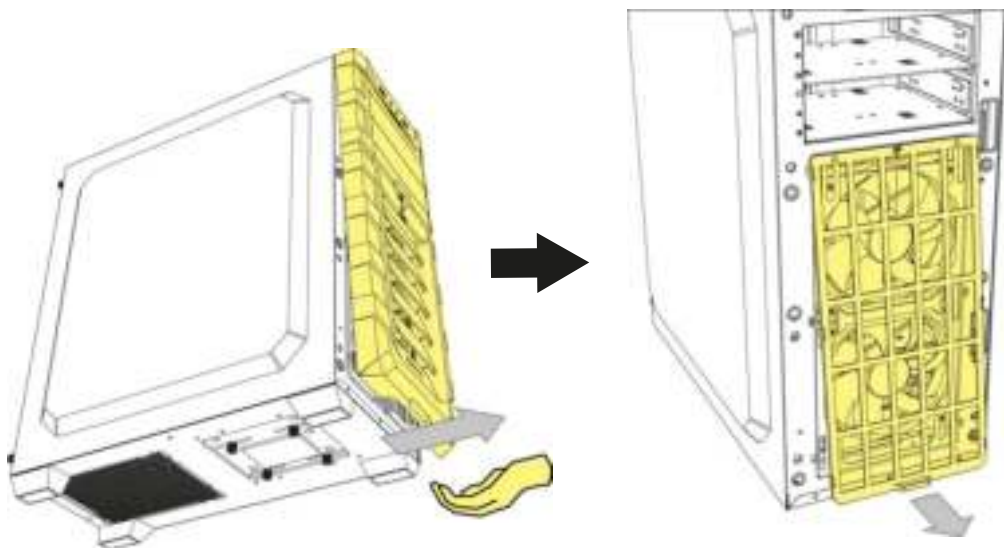



## Extra HDD Cooling Solution

- Optionale HDD-Kühlung
- Plus Cooling Solution HDD
- Soluzione raffreddamento Extra HDD
- Solución de refrigeración adicional HDD
- Extra HDD solução de resfriamento
- Optionele HDD-koeling
- Rozwiązanie do chłodzenia HDD
- Extra HDD-hűtési megoldás
- Instalace extra chlazení HDD
- Instalacia extra chladenia pre HDD
- 硬碟散熱加強方案
- 追加 HDD の冷却方法

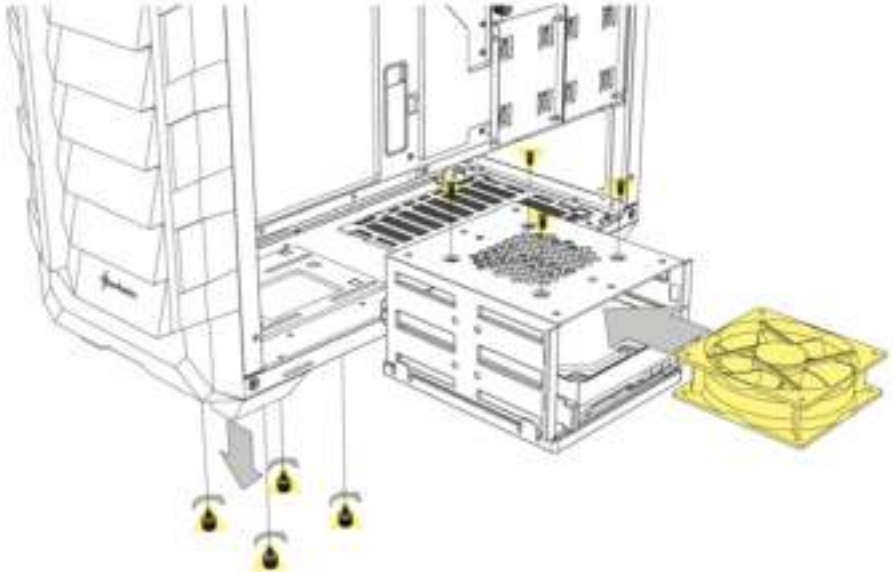

## Extra Space for Power Supply Installation

- Zusätzlicher Platz für die Netzteil-Installation
- Espace supplémentaire pour l'installation de l'alimentation
- Spazio extra per l'installazione dell'alimentatore
- Espacio extra para la instalación de fuente de alimentación
- Espaço extra para a instalação da fonte de alimentação
- Extra ruimte voor installatie van voeding
- Dodatkowe miejsce na montaż zasilacza
- Extra hely a tápegység számára
- Extra prostor pro instalaci napájecího zdroje
- Extra priestor pre inštaláciu napájacieho zdroje
- 增加電源安裝空間
- 電源ユニット設置用の追加スペース

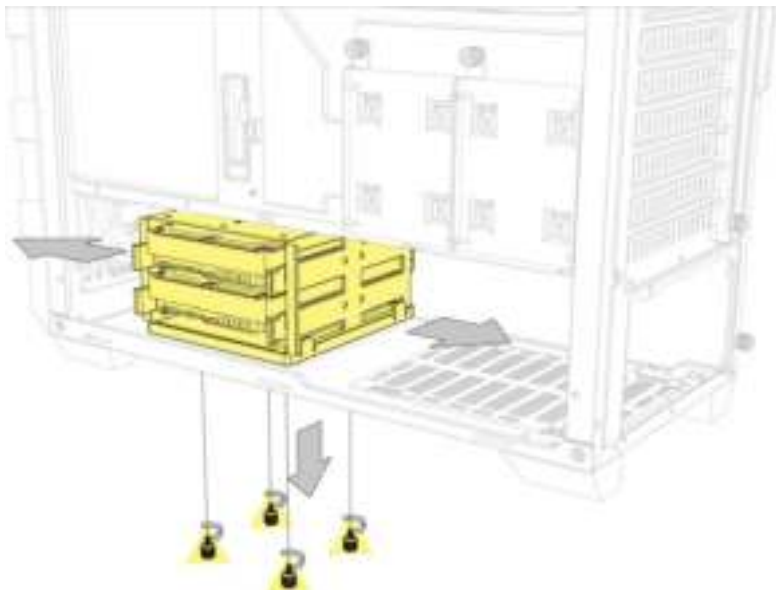

## Top Panel Radiator Installation

- Radiatoreinbau Gehäuseoberseite
- Installation du radiateur du panneau supérieur
- Installazione del radiatore sul pannello superiore
- Instalación de radiador en el panel superior
- Instalação do radiador do painel superior
- Bovenpaneel radiator installatie

- Montáž chladiča na górnym panelu
- A radiátor felszerelése a felső panelre
- Instalace chladiče na horní panel
- Montáž chladiča na horný panel
- 機殻上板水冷排安裝
- トップパネルラジエーターの設置

For window edition only

- 120 mm
- 140 mm
- 240 mm Radiator
- 280 mm
- 360 mm

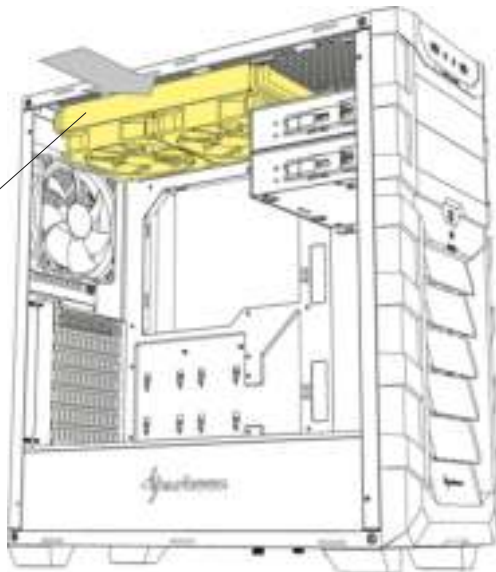

## Front Panel Radiator Installation

- Radiatoreinbau Gehäusefront
- Installation du radiateur du panneau avant
- Installazione del radiatore sul pannello frontale
- Instalación de radiador en el panel frontal
- Instalação do radiador do painel frontal
- Voorpaneel radiator installatie

- Montáž chladičky na panelu prednim
- A radiátor felszerelése az elülső panelre
- Instalace chladiče na přední panel
- Montáž chladiča na predný panel
- 機殻前板水冷排安裝
- フロントパネルラジエーターの設置

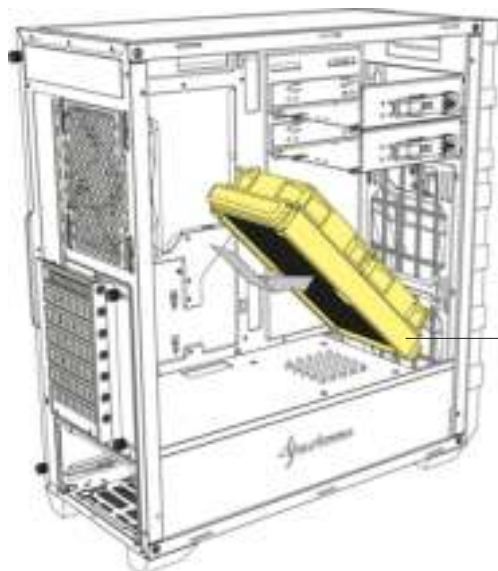

- 120 mm
- 140 mm
- 240 mm Radiator
- 280 mm

## Extra Space for Radiator Installation

- Zusätzlicher Platz für die Radiator-Installation
- Espace supplémentaire pour l'installation de radiateur
- Spazio extra per l'installazione radiatore
- Espacio extra para la instalación de radiador
- Espaço extra para a instalação da radiador
- Extra ruimte voor installatie van radiator

- Dodatkowo miejsce na montaż chłodnicy
- Extra hely a radiátor számára
- Extra prostor pro instalaci chladíče
- Extra priestor pre inštaláciu radiátor
- 增加水冷排安裝空間
- ラジエーター設置用の追加スペース

For window edition only

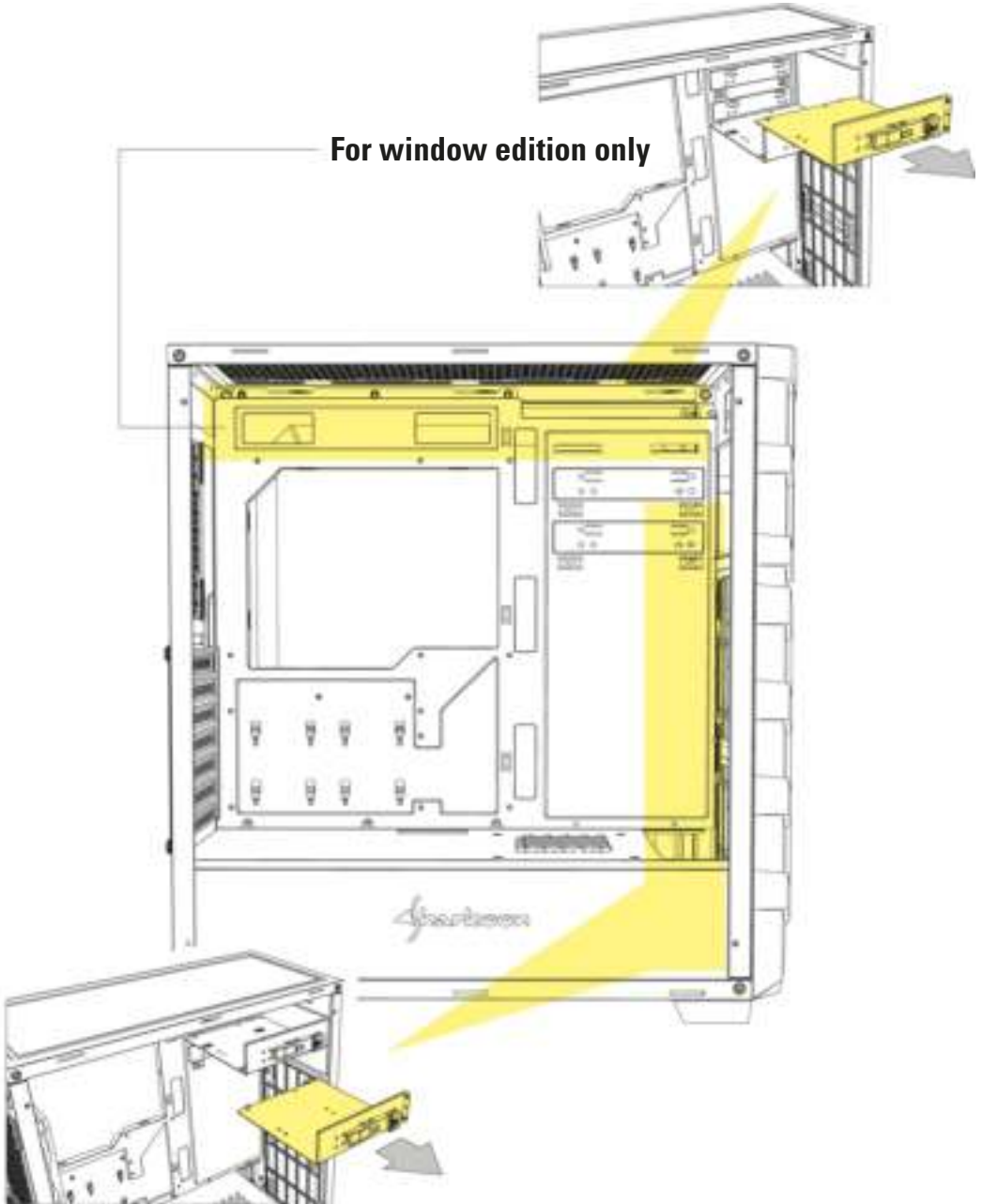

# Rear Panel Radiator Installation

- Radiatoreinbau Gehäuserückseite
- Installation du radiateur du panneau arrière
- Installazione del radiatore sul pannello posteriore
- Instalación de radiador en el panel posterior
- Instalação do radiador no painel traseiro
- Achterpaneel radiator installatie
- Montáž chladičky na panelu tylním
- A radiátor felszerelése a hátsó panelre
- Instalace chladiče na zadní panel
- Montáž chladiča na zadný panel
- 機殻後板水冷排安裝
- リアパネルラジエーターの設置

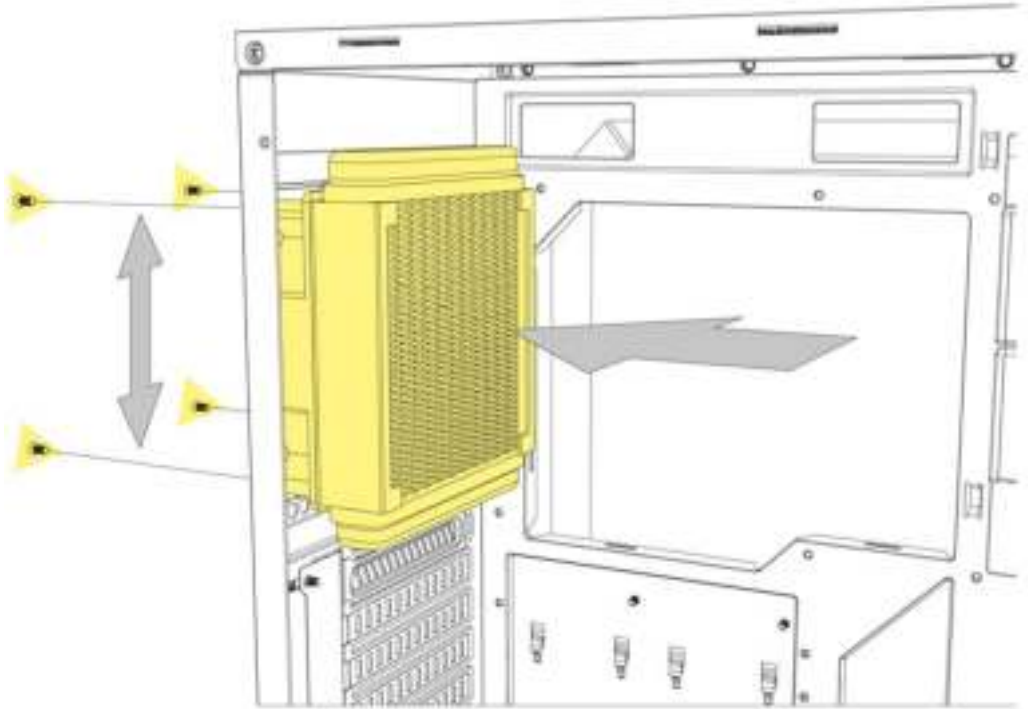

**120 mm Radiator**

## Legal Disclaimer

For potential loss of data, especially due to inappropriate handling, SHARKOON assumes no liability. All named products and descriptions are trademarks and/or registered trademarks of the respective manufacturers and are accepted as protected. As a continuing policy of product improvement at SHARKOON, the design and specifications are subject to change without prior notice. National product specifications may vary. All rights reserved especially (also in extracts) for translation, reprinting, reproduction by copying or other technical means. Infringements will lead to compensation. All rights reserved especially in case of assignation of patent or utility patent. Means of delivery and technical modifications reserved.

## Disposal of your old products

Your product is designed and manufactured with high quality materials and components, which can be recycled and reused.



When this crossed-out wheeled bin symbol is attached to a product, it means the product is covered by the European Directive 2012/19/EU. Please be informed about the local separate collection system for electrical and electronic products. Please act according to your local rules and do not dispose of your old products with your normal household waste. The correct disposal of your old product will help prevent potential negative consequences to the environment and human health.

## Rechtliche Hinweise

Für evtl. auftretenden Datenverlust, insbesondere durch unsachgemäße Handhabung, übernimmt SHARKOON keine Haftung. Alle genannten Produkte und Bezeichnungen sind Warenzeichen und/oder eingetragene Warenzeichen der jeweiligen Hersteller und werden als geschützt anerkannt. Als ein Teil von SHARKOONs Politik der fortwährenden Produktverbesserung unterliegen Produktdesign und -spezifikationen Änderungen ohne vorherige Ankündigung. Die Spezifikationen können in verschiedenen Ländern variieren. Alle Rechte vorbehalten, insbesondere (auch auszugsweise) die der Übersetzung, des Nachdrucks, der Wiedergabe durch Kopieren oder ähnliche Verfahren. Zuwiderhandlungen verpflichten zu Schadenersatz. Alle Rechte vorbehalten, insbesondere für den Fall der Patenterteilung oder GM-Eintragung. Liefermöglichkeiten und technische Änderungen vorbehalten.

## Entsorgung Ihres alten Gerätes

Ihr Gerät wurde unter Verwendung hochwertiger Materialien und Komponenten entwickelt und hergestellt, die recycelt und wiederverwendet werden können.



Befindet sich dieses Symbol (durchgestrichene Abfalltonne auf Rädern) auf dem Gerät, bedeutet dies, dass für dieses Gerät die Europäische Richtlinie 2012/19/EU gilt. Informieren Sie sich über die geltenden Bestimmungen zur getrennten Sammlung von Elektro- und Elektronik-Altgeräten in Ihrem Land. Richten Sie sich bitte nach den geltenden Bestimmungen in Ihrem Land, und entsorgen Sie Altgeräte nicht über Ihren Haushaltsabfall. Durch die korrekte Entsorgung Ihrer Altgeräte werden Umwelt und Menschen vor möglichen negativen Folgen geschützt.

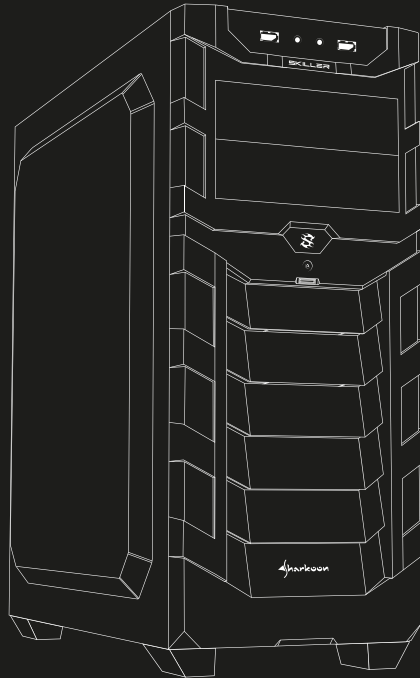

**SHARKOON Technologies GmbH**  
Siemensstraße 38  
35440 Linden  
Germany

**© SHARKOON Technologies 2018**

info@sharkoon.com  
www.sharkoon.com