

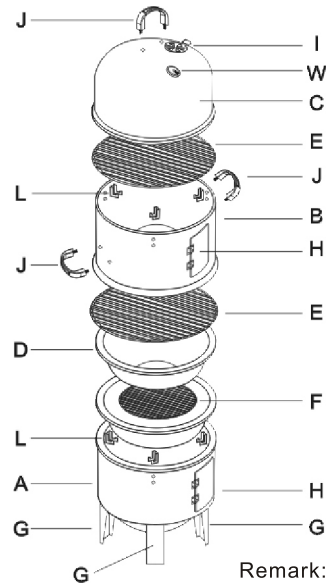















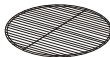

Model 20730 Manual Intruction

Instruction Manual for BBQ Smoker



Remark:

H: screw Φ 3X8
 J/G: Screw Φ 6X14
 L/I: Screw Φ 5X10

A 	1X	B 	1X
C 	1X	D 	2X
E 	2X	F 	1X
G 	3X	H 	2X
I 	1X	J 	3X
Φ 6X14	12pcs	L 	6X
 M6	6pcs	W 	1X
Φ 5X10	7pcs		
 M5	7pcs		
Φ 3X8	8pcs		
 M3	8pcs		

FIRST TIME USE

For the first use, we strongly recommend to have it burn for over 30 mins without food load.

USEFUL HINT SAND PRECAUTIONARY

MEASURES

- This smoker can only be used outdoor.
- Always install this product on a solid surface, away from inflammable and meltable materials.
- Do not use the smoker when windy.
- Use the smoker only after it is completely assembled and all parts are firmly in place.
- Never move the smoker before the fire is completely extinguished and the smoker is cooled off completely.
- Keep children and pets at a safe distance when using.
- Never use liquid fuel to light or stir up the fire.
- Protect yourselves against the fire and steam when opening lid or access doors when the smoker is in use.

INSTRUCTIONS FOR USE

LIGHTING

- Remove lid, upper layer body, cooking grates and drip pan.
- Make sure charcoal grate sits inside the charcoal pan, and the charcoal pan is securely rested on all 3 legs.
- Open door to the lower layer body. If possible, face open door to the wind to enhance fire starting and air circulation within the smoker.
- Place charcoal or wood (not pine wood) into a pyramid shape, in the center of the charcoal grate.
- Start the fire while leaving lid, upper layer body and drip pan off.
- Allow charcoal/wood to burn for about 25 minutes. The coals should be lightly coated in gray ash before starting to cook.
- Spread coals/wood evenly over the charcoal grate to obtain even fire. Close door on the lower layer body.

KEEP THE SMOKING GOING

- Place drip pan securely on the 3 support brackets of the lower layer body.
- You can fill this pan with a little bit of water.
- Place a cooking grate directly on top of the drip pan. Place food on the cooking grate in a single layer with spaces between each piece. This allows smoke and heat to circulate evenly all around the food.
- Place upper layer body on top of the lower layer body. Keep door closed.
- Position the other cooking grate on the support brackets of the upper layer body, and make sure the rim of the cooking grate is resting firmly on the support brackets. Place food on the cooking grate.
- Place lid on the smoker and start cooking!

COOKING TIPS

- During the smoking process, don't lift the lid to check food. Opened lid allows heat to escape, making additional cooking time necessary.
- When removing lid during cooking, lift it towards the side instead of straight up. Lifting lid straight up creates an air flow within the smoker, which will suck up ashes onto the food.

REGULATING THE FIRE

- It's absolutely necessary to keep a consistent, even and low heat environment of +/-70°C inside your smoker. You should just be able to touch the outside of the smoker in area of the dish without burning your hand.
- If the fire is too hot, place lid on smoker and close lid air vent. You can also add in some wet wood chips on the fire. This will lower the temperature and also build up a smoldering smoke for enhanced flavor.
- If the fire is too low, enlarge lid air vent and access door to the lower layer body to let air in and build up the fire.

ADDING WATER DURING COOKING

- Pour water slowly with a funnel or container with a spout through the access door of upper layer body.

ADDING CHARCOAL/WOOD DURING COOKING

- Slowly remove lid from smoker, and carefully open access door to the lower layer body with barbecue mitts
- Use a long tong to add charcoal or wood, avoiding to stir-up ashes and sparks.
- Close door and place lid back on the smoker once the charcoal or wood is burning strong again.

EXTINGUISHING FIRE

- Place lid on the smoker
- Simply close all air vents and doors to extinguish fire. Also try covering coals with sand. Never use water!