

G.SKILL International Enterprise

TEST REPORT

SCOPE OF WORK:

EMC directive (2014/30/EU) – EMC report

Model:

F5-6800U4242G16GX2-RS5W;

F5-6800U4242G16GX2-TZ5K

(Serial models please refer to section 1.2)

REPORT NUMBER

211200131THC-001

ISSUE DATE

Jan. 05, 2022

PAGES

62

DOCUMENT CONTROL NUMBER

GFT-OP-10h (28-Nov-2018)

© 2020 Intertek



EMC TEST REPORT

Applicant:	G.SKILL International Enterprise 6F., No.69, Dongsing Rd., Sinyi Dist., Taipei City 11070, Taiwan
Product:	Memory Module
Model No.:	F5-6800U4242G16GX2-RS5W; F5-6800U4242G16GX2-TZ5K (Serial models please refer to section 1.2)
Brand Name:	NIL
Test Method/ Standard:	EN 55032: 2015+A1: 2020 EN IEC 61000-3-2: 2019 EN 61000-3-3: 2013+A1: 2019 EN 55035: 2017+A11: 2020
Test By:	Intertek Testing Services Taiwan Ltd. Hsinchu Laboratory No. 11, Lane 275, Ko-Nan 1 Street, Chia-Tung Li Shiang-Shan District, Hsinchu City, Taiwan



Mandy Su

Mandy Su
Engineer

Lion Chiu

Lion Chiu
Reviewer

This report is for the exclusive use of Intertek's Client and is provided pursuant to the agreement between Intertek and its Client. Intertek's responsibility and liability are limited to the terms and conditions of the agreement. Intertek assumes no liability to any party, other than to the Client in accordance with the agreement, for any loss, expense or damage occasioned by the use of this report. Only the Client is authorized to permit copying or distribution of this report and then only in its entirety. Any use of the Intertek name or one of its marks for the sale or advertisement of the tested material, product or service must first be approved in writing by Intertek. The observations and test results in this report are relevant only to the sample tested. This report by itself does not imply that the material, product, or service is or has ever been under an Intertek certification program.

Revision History

Report No.	Issue Date	Revision Summary
211200131THC-001	Jan. 05, 2022	Original report

Table of Contents

1. General Information	5
1.1 Identification of the EUT	5
1.2 Additional information about the EUT	5
2. Test Summary	22
3. Test Specifications	23
3.1 Standards.....	23
3.2 Classification of MME.....	23
3.3 Performance criteria.....	24
3.4 Mode of operation during the test.....	25
3.5 Peripherals equipment	25
4. Conducted Emission Test.....	26
4.1 Test Procedure	26
4.2 Test Equipment	26
4.3 Conducted Emission Limit	27
4.4 Conducted Emission Data.....	28
5. Radiated Emission Test	32
5.1.1 Test Procedure from 30 MHz to 1000 MHz	32
5.1.2 Test Equipment.....	33
5.1.3 Radiated Emission Limit	33
5.1.4 Radiated Emission Test Data from 30 MHz to 1000 MHz.....	34
5.2.1 Test Procedure above 1 GHz.....	38
5.2.2 Test Equipment.....	39
5.2.3 Radiated Emission Limit	39
5.2.4 Radiated Emission Test Data above 1 GHz	40
6. Harmonics Test	44
7. Voltage Fluctuations-Flicker Test.....	45
8. Electrostatic Discharge Immunity Test	46
8.1 Purpose.....	46
8.2 Test Set-Up.....	46
8.3 Test Specification	46
8.4 Test Equipment	46
8.5 Test Result.....	47
9. Radiated, Radio-Frequency, Electromagnetic Field Immunity Test.....	48
9.1 Purpose.....	48
9.2 Test Set-Up.....	48
9.3 Test Specification	48
9.4 Test Equipment	49

TEST REPORT

9.5 Generation of the Electromagnetic Field 49

9.6 Test Results 50

10. Electrical Fast Transient/Burst Immunity Test 51

11. Surge Immunity Test 52

12. Immunity to Conducted Disturbances, Inducted by Radio-Frequency Fields..... 53

13. Power Frequency Magnetic Field Immunity Test 54

 13.1 Purpose..... 54

 13.2 Test Set-Up 54

 13.3 Test Condition..... 54

 13.4 Test Equipment. 55

 13.5 Test Result..... 55

14. Voltage Dips, Short Interruptions and Voltage Variations Immunity Test..... 56

Appendix A: Uncertainty 57

Appendix B: Photo of EUT 58

Appendix C1: Conducted Emission Test Set-up 60

Appendix C2: Radiated Emission Test Set-up (Below 1GHz) 61

Appendix C3: Radiated Emission Test Set-up (Above 1GHz) 62

1. General Information

1.1 Identification of the EUT

Product:	Memory Module
Model No.:	F5-6800U4242G16GX2-RS5W; F5-6800U4242G16GX2-TZ5K
Rated Power:	1.2Vdc
Power Cord:	N/A
Sample receiving date:	2021/12/10
Sample condition:	Workable
Testing date:	2021/12/14 ~ 2021/12/17

1.2 Additional information about the EUT

The customer confirmed the series models are identical in IC and different in appearance, color, capacity and speed.

Ripjaws S5			
			
F5-4800U3636A32GA4-RS5K	F5-6600U3636F32GA4-RS5K	F5-6000U4040E32GA1-RS5K	F5-5400U3636C32GA2-RS5K
F5-4800U4040A32GA4-RS5K	F5-6600U4040F32GA4-RS5K	F5-6200U3636F32GA1-RS5K	F5-5400U4040C32GA2-RS5K
F5-5200U3636C32GA4-RS5K	F5-6666U4040P32GA4-RS5K	F5-6200U4040F32GA1-RS5K	F5-5600U3636C32GA2-RS5K
F5-5200U4040A32GA4-RS5K	F5-6800U4040G32GA4-RS5K	F5-6400U3636F32GA1-RS5K	F5-5600U4040C32GA2-RS5K
F5-5400U3636C32GA4-RS5K	F5-6800U4242G32GA4-RS5K	F5-6400U4040F32GA1-RS5K	F5-6000U3636E32GA2-RS5K
F5-5400U4040C32GA4-RS5K	F5-4800U3636A32GA1-RS5K	F5-6600U3636F32GA1-RS5K	F5-6000U4040E32GA2-RS5K
F5-5600U3636C32GA4-RS5K	F5-4800U4040A32GA1-RS5K	F5-6600U4040F32GA1-RS5K	F5-6200U3636F32GA2-RS5K
F5-5600U4040C32GA4-RS5K	F5-5200U3636C32GA1-RS5K	F5-6666U4040P32GA1-RS5K	F5-6200U4040F32GA2-RS5K
F5-6000U3636E32GA4-RS5K	F5-5200U4040A32GA1-RS5K	F5-6800U4040G32GA1-RS5K	F5-6400U3636F32GA2-RS5K
F5-6000U4040E32GA4-RS5K	F5-5400U3636C32GA1-RS5K	F5-6800U4242G32GA1-RS5K	F5-6400U4040F32GA2-RS5K
F5-6200U3636F32GA4-RS5K	F5-5400U4040C32GA1-RS5K	F5-4800U3636A32GA2-RS5K	F5-6600U3636F32GA2-RS5K
F5-6200U4040F32GA4-RS5K	F5-5600U3636C32GA1-RS5K	F5-4800U4040A32GA2-RS5K	F5-6600U4040F32GA2-RS5K
F5-6400U3636F32GA4-RS5K	F5-5600U4040C32GA1-RS5K	F5-5200U3636C32GA2-RS5K	F5-6666U4040P32GA2-RS5K
F5-6400U4040F32GA4-RS5K	F5-6000U3636E32GA1-RS5K	F5-5200U4040A32GA2-RS5K	F5-6800U4040G32GA2-RS5K

Ripjaws S5			
			
F5-6800U4242G32GA2-RS5K	F5-6200U3636F32GX1-RS5K	F5-5200U3636C16GA4-RS5K	F5-6400U4040F16GA1-RS5K
F5-4800U3636A32GX4-RS5K	F5-6200U4040F32GX1-RS5K	F5-5200U4040A16GA4-RS5K	F5-6600U3636F16GA1-RS5K
F5-4800U4040A32GX4-RS5K	F5-6400U3636F32GX1-RS5K	F5-5400U3636C16GA4-RS5K	F5-6600U4040F16GA1-RS5K
F5-5200U3636C32GX4-RS5K	F5-6400U4040F32GX1-RS5K	F5-5400U4040C16GA4-RS5K	F5-6666U4040P16GA1-RS5K
F5-5200U4040A32GX4-RS5K	F5-6600U3636F32GX1-RS5K	F5-5600U3636C16GA4-RS5K	F5-6800U4040G16GA1-RS5K
F5-5400U3636C32GX4-RS5K	F5-6600U4040F32GX1-RS5K	F5-5600U4040C16GA4-RS5K	F5-6800U4242G16GA1-RS5K
F5-5400U4040C32GX4-RS5K	F5-6666U4040P32GX1-RS5K	F5-6000U3636E16GA4-RS5K	F5-4800U3636A16GA2-RS5K
F5-5600U3636C32GX4-RS5K	F5-6800U4040G32GX1-RS5K	F5-6000U4040E16GA4-RS5K	F5-4800U4040A16GA2-RS5K
F5-5600U4040C32GX4-RS5K	F5-6800U4242G32GX1-RS5K	F5-6200U3636F16GA4-RS5K	F5-5200U3636C16GA2-RS5K
F5-6000U3636E32GX4-RS5K	F5-4800U3636A32GX2-RS5K	F5-6200U4040F16GA4-RS5K	F5-5200U4040A16GA2-RS5K
F5-6000U4040E32GX4-RS5K	F5-4800U4040A32GX2-RS5K	F5-6400U3636F16GA4-RS5K	F5-5400U3636C16GA2-RS5K
F5-6200U3636F32GX4-RS5K	F5-5200U3636C32GX2-RS5K	F5-6400U4040F16GA4-RS5K	F5-5400U4040C16GA2-RS5K
F5-6200U4040F32GX4-RS5K	F5-5200U4040A32GX2-RS5K	F5-6600U3636F16GA4-RS5K	F5-5600U3636C16GA2-RS5K
F5-6400U3636F32GX4-RS5K	F5-5400U3636C32GX2-RS5K	F5-6600U4040F16GA4-RS5K	F5-5600U4040C16GA2-RS5K
F5-6400U4040F32GX4-RS5K	F5-5400U4040C32GX2-RS5K	F5-6666U4040P16GA4-RS5K	F5-6000U3636E16GA2-RS5K
F5-6600U3636F32GX4-RS5K	F5-5600U3636C32GX2-RS5K	F5-6800U4040G16GA4-RS5K	F5-6000U4040E16GA2-RS5K
F5-6600U4040F32GX4-RS5K	F5-5600U4040C32GX2-RS5K	F5-6800U4242G16GA4-RS5K	F5-6200U3636F16GA2-RS5K
F5-6666U4040P32GX4-RS5K	F5-6000U3636E32GX2-RS5K	F5-4800U3636A16GA1-RS5K	F5-6200U4040F16GA2-RS5K
F5-6800U4040G32GX4-RS5K	F5-6000U4040E32GX2-RS5K	F5-4800U4040A16GA1-RS5K	F5-6400U3636F16GA2-RS5K
F5-6800U4242G32GX4-RS5K	F5-6200U3636F32GX2-RS5K	F5-5200U3636C16GA1-RS5K	F5-6400U4040F16GA2-RS5K
F5-4800U3636A32GX1-RS5K	F5-6200U4040F32GX2-RS5K	F5-5200U4040A16GA1-RS5K	F5-6600U3636F16GA2-RS5K
F5-4800U4040A32GX1-RS5K	F5-6400U3636F32GX2-RS5K	F5-5400U3636C16GA1-RS5K	F5-6600U4040F16GA2-RS5K
F5-5200U3636C32GX1-RS5K	F5-6400U4040F32GX2-RS5K	F5-5400U4040C16GA1-RS5K	F5-6666U4040P16GA2-RS5K
F5-5200U4040A32GX1-RS5K	F5-6600U3636F32GX2-RS5K	F5-5600U3636C16GA1-RS5K	F5-6800U4040G16GA2-RS5K
F5-5400U3636C32GX1-RS5K	F5-6600U4040F32GX2-RS5K	F5-5600U4040C16GA1-RS5K	F5-6800U4242G16GA2-RS5K
F5-5400U4040C32GX1-RS5K	F5-6666U4040P32GX2-RS5K	F5-6000U3636E16GA1-RS5K	F5-4800U3636A16GX4-RS5K
F5-5600U3636C32GX1-RS5K	F5-6800U4040G32GX2-RS5K	F5-6000U4040E16GA1-RS5K	F5-4800U4040A16GX4-RS5K
F5-5600U4040C32GX1-RS5K	F5-6800U4242G32GX2-RS5K	F5-6200U3636F16GA1-RS5K	F5-5200U3636C16GX4-RS5K
F5-6000U3636E32GX1-RS5K	F5-4800U3636A16GA4-RS5K	F5-6200U4040F16GA1-RS5K	F5-5200U4040D16GX4-RS5K
F5-6000U4040E32GX1-RS5K	F5-4800U4040A16GA4-RS5K	F5-6400U3636F16GA1-RS5K	F5-5200U4040A16GX4-RS5K

Ripjaws S5	
	
F5-5400U3636C16GX4-RS5K	F5-6600U4040F16GX1-RS5K
F5-5400U4040C16GX4-RS5K	F5-6666U4040P16GX1-RS5K
F5-5600U3636C16GX4-RS5K	F5-6800U4040G16GX1-RS5K
F5-5600U4040C16GX4-RS5K	F5-6800U4242G16GX1-RS5K
F5-6000U3636E16GX4-RS5K	F5-4800U3636A16GX2-RS5K
F5-6000U4040E16GX4-RS5K	F5-4800U4040A16GX2-RS5K
F5-6200U3636F16GX4-RS5K	F5-5200U3636C16GX2-RS5K
F5-6200U4040F16GX4-RS5K	F5-5200U4040A16GX2-RS5K
F5-6400U3636F16GX4-RS5K	F5-5400U3636C16GX2-RS5K
F5-6400U4040F16GX4-RS5K	F5-5400U4040C16GX2-RS5K
F5-6600U3636F16GX4-RS5K	F5-5600U3636C16GX2-RS5K
F5-6600U4040F16GX4-RS5K	F5-5600U4040C16GX2-RS5K
F5-6666U4040P16GX4-RS5K	F5-6000U3636E16GX2-RS5K
F5-6800U4040G16GX4-RS5K	F5-6000U4040E16GX2-RS5K
F5-6800U4242G16GX4-RS5K	F5-6200U3636F16GX2-RS5K
F5-4800U3636A16GX1-RS5K	F5-6200U4040F16GX2-RS5K
F5-4800U4040A16GX1-RS5K	F5-6400U3636F16GX2-RS5K
F5-5200U3636C16GX1-RS5K	F5-6400U4040F16GX2-RS5K
F5-5200U4040A16GX1-RS5K	F5-6600U3636F16GX2-RS5K
F5-5400U3636C16GX1-RS5K	F5-6600U4040F16GX2-RS5K
F5-5400U4040C16GX1-RS5K	F5-6666U4040P16GX2-RS5K
F5-5600U3636C16GX1-RS5K	F5-6800U4040G16GX2-RS5K
F5-5600U4040C16GX1-RS5K	F5-6800U4242G16GX2-RS5K
F5-6000U3636E16GX1-RS5K	
F5-6000U4040E16GX1-RS5K	
F5-6200U3636F16GX1-RS5K	
F5-6200U4040F16GX1-RS5K	
F5-6400U3636F16GX1-RS5K	
F5-6400U4040F16GX1-RS5K	
F5-6600U3636F16GX1-RS5K	

Ripjaws S5			
			
F5-4800J3636A32GA4-RS5K	F5-6200J4040F32GA1-RS5K	F5-5200J4040A32GX4-RS5K	F5-6600J3636F32GX1-RS5K
F5-4800J4040A32GA4-RS5K	F5-6400J3636G32GA1-RS5K	F5-5400J3636C32GX4-RS5K	F5-6600J4040F32GX1-RS5K
F5-5200J3636C32GA4-RS5K	F5-6400J4040G32GA1-RS5K	F5-5400J4040C32GX4-RS5K	F5-6666J4040P32GX1-RS5K
F5-5200J4040A32GA4-RS5K	F5-6600J3636F32GA1-RS5K	F5-5600J3636C32GX4-RS5K	F5-6800J4040G32GX1-RS5K
F5-5400J3636C32GA4-RS5K	F5-6600J4040F32GA1-RS5K	F5-5600J4040C32GX4-RS5K	F5-6800J4242G32GX1-RS5K
F5-5400J4040C32GA4-RS5K	F5-6666J4040P32GA1-RS5K	F5-6000J3636F32GX4-RS5K	F5-4800J3636A32GX2-RS5K
F5-5600J3636C32GA4-RS5K	F5-6800J4040G32GA1-RS5K	F5-6000J4040F32GX4-RS5K	F5-4800J4040A32GX2-RS5K
F5-5600J4040C32GA4-RS5K	F5-6800J4242G32GA1-RS5K	F5-6200J3636F32GX4-RS5K	F5-5200J3636C32GX2-RS5K
F5-6000J3636F32GA4-RS5K	F5-4800J3636A32GA2-RS5K	F5-6200J4040F32GX4-RS5K	F5-5200J4040A32GX2-RS5K
F5-6000J4040F32GA4-RS5K	F5-4800J4040A32GA2-RS5K	F5-6400J3636G32GX4-RS5K	F5-5400J3636C32GX2-RS5K
F5-6200J3636F32GA4-RS5K	F5-5200J3636C32GA2-RS5K	F5-6400J4040G32GX4-RS5K	F5-5400J4040C32GX2-RS5K
F5-6200J4040F32GA4-RS5K	F5-5200J4040A32GA2-RS5K	F5-6600J3636F32GX4-RS5K	F5-5600J3636C32GX2-RS5K
F5-6400J3636G32GA4-RS5K	F5-5400J3636C32GA2-RS5K	F5-6600J4040F32GX4-RS5K	F5-5600J4040C32GX2-RS5K
F5-6400J4040G32GA4-RS5K	F5-5400J4040C32GA2-RS5K	F5-6666J4040P32GX4-RS5K	F5-6000J3636F32GX2-RS5K
F5-6600J3636F32GA4-RS5K	F5-5600J3636C32GA2-RS5K	F5-6800J4040G32GX4-RS5K	F5-6000J4040F32GX2-RS5K
F5-6600J4040F32GA4-RS5K	F5-5600J4040C32GA2-RS5K	F5-6800J4242G32GX4-RS5K	F5-6200J3636F32GX2-RS5K
F5-6666J4040P32GA4-RS5K	F5-6000J3636F32GA2-RS5K	F5-4800J3636A32GX1-RS5K	F5-6200J4040F32GX2-RS5K
F5-6800J4040G32GA4-RS5K	F5-6000J4040F32GA2-RS5K	F5-4800J4040A32GX1-RS5K	F5-6400J3636G32GX2-RS5K
F5-6800J4242G32GA4-RS5K	F5-6200J3636F32GA2-RS5K	F5-5200J3636C32GX1-RS5K	F5-6400J4040G32GX2-RS5K
F5-4800J3636A32GA1-RS5K	F5-6200J4040F32GA2-RS5K	F5-5200J4040A32GX1-RS5K	F5-6600J3636F32GX2-RS5K
F5-4800J4040A32GA1-RS5K	F5-6400J3636G32GA2-RS5K	F5-5400J3636C32GX1-RS5K	F5-6600J4040F32GX2-RS5K
F5-5200J3636C32GA1-RS5K	F5-6400J4040G32GA2-RS5K	F5-5400J4040C32GX1-RS5K	F5-6666J4040P32GX2-RS5K
F5-5200J4040A32GA1-RS5K	F5-6600J3636F32GA2-RS5K	F5-5600J3636C32GX1-RS5K	F5-6800J4040G32GX2-RS5K
F5-5400J3636C32GA1-RS5K	F5-6600J4040F32GA2-RS5K	F5-5600J4040C32GX1-RS5K	F5-6800J4242G32GX2-RS5K
F5-5400J4040C32GA1-RS5K	F5-6666J4040P32GA2-RS5K	F5-6000J3636F32GX1-RS5K	F5-4800J3636A16GA4-RS5K
F5-5600J3636C32GA1-RS5K	F5-6800J4040G32GA2-RS5K	F5-6000J4040F32GX1-RS5K	F5-4800J4040A16GA4-RS5K
F5-5600J4040C32GA1-RS5K	F5-6800J4242G32GA2-RS5K	F5-6200J3636F32GX1-RS5K	F5-5200J3636C16GA4-RS5K
F5-6000J3636F32GA1-RS5K	F5-4800J3636A32GX4-RS5K	F5-6200J4040F32GX1-RS5K	F5-5200J4040A16GA4-RS5K
F5-6000J4040F32GA1-RS5K	F5-4800J4040A32GX4-RS5K	F5-6400J3636G32GX1-RS5K	F5-5400J3636C16GA4-RS5K
F5-6200J3636F32GA1-RS5K	F5-5200J3636C32GX4-RS5K	F5-6400J4040G32GX1-RS5K	F5-5400J4040C16GA4-RS5K

Ripjaws S5			
			
F5-5600J3636C16GA4-RS5K	F5-6800J4040G16GA1-RS5K	F5-6000J3636F16GX4-RS5K	F5-4800J3636A16GX2-RS5K
F5-5600J4040C16GA4-RS5K	F5-6800J4242G16GA1-RS5K	F5-6000J4040F16GX4-RS5K	F5-4800J4040A16GX2-RS5K
F5-6000J3636F16GA4-RS5K	F5-4800J3636A16GA2-RS5K	F5-6200J3636F16GX4-RS5K	F5-5200J3636C16GX2-RS5K
F5-6000J4040F16GA4-RS5K	F5-4800J4040A16GA2-RS5K	F5-6200J4040F16GX4-RS5K	F5-5200J4040A16GX2-RS5K
F5-6200J3636F16GA4-RS5K	F5-5200J3636C16GA2-RS5K	F5-6400J3636G16GX4-RS5K	F5-5400J3636C16GX2-RS5K
F5-6200J4040F16GA4-RS5K	F5-5200J4040A16GA2-RS5K	F5-6400J4040G16GX4-RS5K	F5-5400J4040C16GX2-RS5K
F5-6400J3636G16GA4-RS5K	F5-5400J3636C16GA2-RS5K	F5-6600J3636F16GX4-RS5K	F5-5600J3636C16GX2-RS5K
F5-6400J4040G16GA4-RS5K	F5-5400J4040C16GA2-RS5K	F5-6600J4040F16GX4-RS5K	F5-5600J4040C16GX2-RS5K
F5-6600J3636F16GA4-RS5K	F5-5600J3636C16GA2-RS5K	F5-6666J4040P16GX4-RS5K	F5-6000J3636F16GX2-RS5K
F5-6600J4040F16GA4-RS5K	F5-5600J4040C16GA2-RS5K	F5-6800J4040G16GX4-RS5K	F5-6000J4040F16GX2-RS5K
F5-6666J4040P16GA4-RS5K	F5-6000J3636F16GA2-RS5K	F5-6800J4242G16GX4-RS5K	F5-6200J3636F16GX2-RS5K
F5-6800J4040G16GA4-RS5K	F5-6000J4040F16GA2-RS5K	F5-4800J3636A16GX1-RS5K	F5-6200J4040F16GX2-RS5K
F5-6800J4242G16GA4-RS5K	F5-6200J3636F16GA2-RS5K	F5-4800J4040A16GX1-RS5K	F5-6400J3636G16GX2-RS5K
F5-4800J3636A16GA1-RS5K	F5-6200J4040F16GA2-RS5K	F5-5200J3636C16GX1-RS5K	F5-6400J4040G16GX2-RS5K
F5-4800J4040A16GA1-RS5K	F5-6400J3636G16GA2-RS5K	F5-5200J4040A16GX1-RS5K	F5-6600J3636F16GX2-RS5K
F5-5200J3636C16GA1-RS5K	F5-6400J4040G16GA2-RS5K	F5-5400J3636C16GX1-RS5K	F5-6600J4040F16GX2-RS5K
F5-5200J4040A16GA1-RS5K	F5-6600J3636F16GA2-RS5K	F5-5400J4040C16GX1-RS5K	F5-6666J4040P16GX2-RS5K
F5-5400J3636C16GA1-RS5K	F5-6600J4040F16GA2-RS5K	F5-5600J3636C16GX1-RS5K	F5-6800J4040G16GX2-RS5K
F5-5400J4040C16GA1-RS5K	F5-6666J4040P16GA2-RS5K	F5-5600J4040C16GX1-RS5K	F5-6800J4242G16GX2-RS5K
F5-5600J3636C16GA1-RS5K	F5-6800J4040G16GA2-RS5K	F5-6000J3636F16GX1-RS5K	
F5-5600J4040C16GA1-RS5K	F5-6800J4242G16GA2-RS5K	F5-6000J4040F16GX1-RS5K	
F5-6000J3636F16GA1-RS5K	F5-4800J3636A16GX4-RS5K	F5-6200J3636F16GX1-RS5K	
F5-6000J4040F16GA1-RS5K	F5-4800J4040A16GX4-RS5K	F5-6200J4040F16GX1-RS5K	
F5-6200J3636F16GA1-RS5K	F5-5200J3636C16GX4-RS5K	F5-6400J3636G16GX1-RS5K	
F5-6200J4040F16GA1-RS5K	F5-5200J4040D16GX4-RS5K	F5-6400J4040G16GX1-RS5K	
F5-6400J3636G16GA1-RS5K	F5-5200J4040A16GX4-RS5K	F5-6600J3636F16GX1-RS5K	
F5-6400J4040G16GA1-RS5K	F5-5400J3636C16GX4-RS5K	F5-6600J4040F16GX1-RS5K	
F5-6600J3636F16GA1-RS5K	F5-5400J4040C16GX4-RS5K	F5-6666J4040P16GX1-RS5K	
F5-6600J4040F16GA1-RS5K	F5-5600J3636C16GX4-RS5K	F5-6800J4040G16GX1-RS5K	
F5-6666J4040P16GA1-RS5K	F5-5600J4040C16GX4-RS5K	F5-6800J4242G16GX1-RS5K	

Ripjaws S5



F5-4800U3636A32GA4-RS5W	F5-6200U4040F32GA1-RS5W	F5-5200U4040A32GX4-RS5W	F5-6600U3636F32GX1-RS5W
F5-4800U4040A32GA4-RS5W	F5-6400U3636F32GA1-RS5W	F5-5400U3636C32GX4-RS5W	F5-6600U4040F32GX1-RS5W
F5-5200U3636C32GA4-RS5W	F5-6400U4040F32GA1-RS5W	F5-5400U4040C32GX4-RS5W	F5-6666U4040P32GX1-RS5W
F5-5200U4040A32GA4-RS5W	F5-6600U3636F32GA1-RS5W	F5-5600U3636C32GX4-RS5W	F5-6800U4040G32GX1-RS5W
F5-5400U3636C32GA4-RS5W	F5-6600U4040F32GA1-RS5W	F5-5600U4040C32GX4-RS5W	F5-6800U4242G32GX1-RS5W
F5-5400U4040C32GA4-RS5W	F5-6666U4040P32GA1-RS5W	F5-6000U3636E32GX4-RS5W	F5-4800U3636A32GX2-RS5W
F5-5600U3636C32GA4-RS5W	F5-6800U4040G32GA1-RS5W	F5-6000U4040E32GX4-RS5W	F5-4800U4040A32GX2-RS5W
F5-5600U4040C32GA4-RS5W	F5-6800U4242G32GA1-RS5W	F5-6200U3636F32GX4-RS5W	F5-5200U3636C32GX2-RS5W
F5-6000U3636E32GA4-RS5W	F5-4800U3636A32GA2-RS5W	F5-6200U4040F32GX4-RS5W	F5-5200U4040A32GX2-RS5W
F5-6000U4040E32GA4-RS5W	F5-4800U4040A32GA2-RS5W	F5-6400U3636F32GX4-RS5W	F5-5400U3636C32GX2-RS5W
F5-6200U3636F32GA4-RS5W	F5-5200U3636C32GA2-RS5W	F5-6400U4040F32GX4-RS5W	F5-5400U4040C32GX2-RS5W
F5-6200U4040F32GA4-RS5W	F5-5200U4040A32GA2-RS5W	F5-6600U3636F32GX4-RS5W	F5-5600U3636C32GX2-RS5W
F5-6400U3636F32GA4-RS5W	F5-5400U3636C32GA2-RS5W	F5-6600U4040F32GX4-RS5W	F5-5600U4040C32GX2-RS5W
F5-6400U4040F32GA4-RS5W	F5-5400U4040C32GA2-RS5W	F5-6666U4040P32GX4-RS5W	F5-6000U3636E32GX2-RS5W
F5-6600U3636F32GA4-RS5W	F5-5600U3636C32GA2-RS5W	F5-6800U4040G32GX4-RS5W	F5-6000U4040E32GX2-RS5W
F5-6600U4040F32GA4-RS5W	F5-5600U4040C32GA2-RS5W	F5-6800U4242G32GX4-RS5W	F5-6200U3636F32GX2-RS5W
F5-6666U4040P32GA4-RS5W	F5-6000U3636E32GA2-RS5W	F5-4800U3636A32GX1-RS5W	F5-6200U4040F32GX2-RS5W
F5-6800U4040G32GA4-RS5W	F5-6000U4040E32GA2-RS5W	F5-4800U4040A32GX1-RS5W	F5-6400U3636F32GX2-RS5W
F5-6800U4242G32GA4-RS5W	F5-6200U3636F32GA2-RS5W	F5-5200U3636C32GX1-RS5W	F5-6400U4040F32GX2-RS5W
F5-4800U3636A32GA1-RS5W	F5-6200U4040F32GA2-RS5W	F5-5200U4040A32GX1-RS5W	F5-6600U3636F32GX2-RS5W
F5-4800U4040A32GA1-RS5W	F5-6400U3636F32GA2-RS5W	F5-5400U3636C32GX1-RS5W	F5-6600U4040F32GX2-RS5W
F5-5200U3636C32GA1-RS5W	F5-6400U4040F32GA2-RS5W	F5-5400U4040C32GX1-RS5W	F5-6666U4040P32GX2-RS5W
F5-5200U4040A32GA1-RS5W	F5-6600U3636F32GA2-RS5W	F5-5600U3636C32GX1-RS5W	F5-6800U4040G32GX2-RS5W
F5-5400U3636C32GA1-RS5W	F5-6600U4040F32GA2-RS5W	F5-5600U4040C32GX1-RS5W	F5-6800U4242G32GX2-RS5W
F5-5400U4040C32GA1-RS5W	F5-6666U4040P32GA2-RS5W	F5-6000U3636E32GX1-RS5W	F5-4800U3636A16GA4-RS5W
F5-5600U3636C32GA1-RS5W	F5-6800U4040G32GA2-RS5W	F5-6000U4040E32GX1-RS5W	F5-4800U4040A16GA4-RS5W
F5-5600U4040C32GA1-RS5W	F5-6800U4242G32GA2-RS5W	F5-6200U3636F32GX1-RS5W	F5-5200U3636C16GA4-RS5W
F5-6000U3636E32GA1-RS5W	F5-4800U3636A32GX4-RS5W	F5-6200U4040F32GX1-RS5W	F5-5200U4040A16GA4-RS5W
F5-6000U4040E32GA1-RS5W	F5-4800U4040A32GX4-RS5W	F5-6400U3636F32GX1-RS5W	F5-5400U3636C16GA4-RS5W
F5-6200U3636F32GA1-RS5W	F5-5200U3636C32GX4-RS5W	F5-6400U4040F32GX1-RS5W	F5-5400U4040C16GA4-RS5W

Ripjaws S5



F5-5600U3636C16GA4-RS5W	F5-6800U4040G16GA1-RS5W	F5-6000U3636E16GX4-RS5W	F5-4800U3636A16GX2-RS5W
F5-5600U4040C16GA4-RS5W	F5-6800U4242G16GA1-RS5W	F5-6000U4040E16GX4-RS5W	F5-4800U4040A16GX2-RS5W
F5-6000U3636E16GA4-RS5W	F5-4800U3636A16GA2-RS5W	F5-6200U3636F16GX4-RS5W	F5-5200U3636C16GX2-RS5W
F5-6000U4040E16GA4-RS5W	F5-4800U4040A16GA2-RS5W	F5-6200U4040F16GX4-RS5W	F5-5200U4040A16GX2-RS5W
F5-6200U3636F16GA4-RS5W	F5-5200U3636C16GA2-RS5W	F5-6400U3636F16GX4-RS5W	F5-5400U3636C16GX2-RS5W
F5-6200U4040F16GA4-RS5W	F5-5200U4040A16GA2-RS5W	F5-6400U4040F16GX4-RS5W	F5-5400U4040C16GX2-RS5W
F5-6400U3636F16GA4-RS5W	F5-5400U3636C16GA2-RS5W	F5-6600U3636F16GX4-RS5W	F5-5600U3636C16GX2-RS5W
F5-6400U4040F16GA4-RS5W	F5-5400U4040C16GA2-RS5W	F5-6600U4040F16GX4-RS5W	F5-5600U4040C16GX2-RS5W
F5-6600U3636F16GA4-RS5W	F5-5600U3636C16GA2-RS5W	F5-6666U4040P16GX4-RS5W	F5-6000U3636E16GX2-RS5W
F5-6600U4040F16GA4-RS5W	F5-5600U4040C16GA2-RS5W	F5-6800U4040G16GX4-RS5W	F5-6000U4040E16GX2-RS5W
F5-6666U4040P16GA4-RS5W	F5-6000U3636E16GA2-RS5W	F5-6800U4242G16GX4-RS5W	F5-6200U3636F16GX2-RS5W
F5-6800U4040G16GA4-RS5W	F5-6000U4040E16GA2-RS5W	F5-4800U3636A16GX1-RS5W	F5-6200U4040F16GX2-RS5W
F5-6800U4242G16GA4-RS5W	F5-6200U3636F16GA2-RS5W	F5-4800U4040A16GX1-RS5W	F5-6400U3636F16GX2-RS5W
F5-4800U3636A16GA1-RS5W	F5-6200U4040F16GA2-RS5W	F5-5200U3636C16GX1-RS5W	F5-6400U4040F16GX2-RS5W
F5-4800U4040A16GA1-RS5W	F5-6400U3636F16GA2-RS5W	F5-5200U4040A16GX1-RS5W	F5-6600U3636F16GX2-RS5W
F5-5200U3636C16GA1-RS5W	F5-6400U4040F16GA2-RS5W	F5-5400U3636C16GX1-RS5W	F5-6600U4040F16GX2-RS5W
F5-5200U4040A16GA1-RS5W	F5-6600U3636F16GA2-RS5W	F5-5400U4040C16GX1-RS5W	F5-6666U4040P16GX2-RS5W
F5-5400U3636C16GA1-RS5W	F5-6600U4040F16GA2-RS5W	F5-5600U3636C16GX1-RS5W	F5-6800U4040G16GX2-RS5W
F5-5400U4040C16GA1-RS5W	F5-6666U4040P16GA2-RS5W	F5-5600U4040C16GX1-RS5W	F5-6800U4242G16GX2-RS5W
F5-5600U3636C16GA1-RS5W	F5-6800U4040G16GA2-RS5W	F5-6000U3636E16GX1-RS5W	
F5-5600U4040C16GA1-RS5W	F5-6800U4242G16GA2-RS5W	F5-6000U4040E16GX1-RS5W	
F5-6000U3636E16GA1-RS5W	F5-4800U3636A16GX4-RS5W	F5-6200U3636F16GX1-RS5W	
F5-6000U4040E16GA1-RS5W	F5-4800U4040A16GX4-RS5W	F5-6200U4040F16GX1-RS5W	
F5-6200U3636F16GA1-RS5W	F5-5200U3636C16GX4-RS5W	F5-6400U3636F16GX1-RS5W	
F5-6200U4040F16GA1-RS5W	F5-5200U4040D16GX4-RS5W	F5-6400U4040F16GX1-RS5W	
F5-6400U3636F16GA1-RS5W	F5-5200U4040A16GX4-RS5W	F5-6600U3636F16GX1-RS5W	
F5-6400U4040F16GA1-RS5W	F5-5400U3636C16GX4-RS5W	F5-6600U4040F16GX1-RS5W	
F5-6600U3636F16GA1-RS5W	F5-5400U4040C16GX4-RS5W	F5-6666U4040P16GX1-RS5W	
F5-6600U4040F16GA1-RS5W	F5-5600U3636C16GX4-RS5W	F5-6800U4040G16GX1-RS5W	
F5-6666U4040P16GA1-RS5W	F5-5600U4040C16GX4-RS5W	F5-6800U4242G16GX1-RS5W	

Ripjaws S5



F5-4800J3636A32GA4-RS5W	F5-6200J4040F32GA1-RS5W	F5-5200J4040A32GX4-RS5W	F5-6600J3636F32GX1-RS5W
F5-4800J4040A32GA4-RS5W	F5-6400J3636G32GA1-RS5W	F5-5400J3636C32GX4-RS5W	F5-6600J4040F32GX1-RS5W
F5-5200J3636C32GA4-RS5W	F5-6400J4040G32GA1-RS5W	F5-5400J4040C32GX4-RS5W	F5-6666J4040P32GX1-RS5W
F5-5200J4040A32GA4-RS5W	F5-6600J3636F32GA1-RS5W	F5-5600J3636C32GX4-RS5W	F5-6800J4040G32GX1-RS5W
F5-5400J3636C32GA4-RS5W	F5-6600J4040F32GA1-RS5W	F5-5600J4040C32GX4-RS5W	F5-6800J4242G32GX1-RS5W
F5-5400J4040C32GA4-RS5W	F5-6666J4040P32GA1-RS5W	F5-6000J3636F32GX4-RS5W	F5-4800J3636A32GX2-RS5W
F5-5600J3636C32GA4-RS5W	F5-6800J4040G32GA1-RS5W	F5-6000J4040F32GX4-RS5W	F5-4800J4040A32GX2-RS5W
F5-5600J4040C32GA4-RS5W	F5-6800J4242G32GA1-RS5W	F5-6200J3636F32GX4-RS5W	F5-5200J3636C32GX2-RS5W
F5-6000J3636F32GA4-RS5W	F5-4800J3636A32GA2-RS5W	F5-6200J4040F32GX4-RS5W	F5-5200J4040A32GX2-RS5W
F5-6000J4040F32GA4-RS5W	F5-4800J4040A32GA2-RS5W	F5-6400J3636G32GX4-RS5W	F5-5400J3636C32GX2-RS5W
F5-6200J3636F32GA4-RS5W	F5-5200J3636C32GA2-RS5W	F5-6400J4040G32GX4-RS5W	F5-5400J4040C32GX2-RS5W
F5-6200J4040F32GA4-RS5W	F5-5200J4040A32GA2-RS5W	F5-6600J3636F32GX4-RS5W	F5-5600J3636C32GX2-RS5W
F5-6400J3636G32GA4-RS5W	F5-5400J3636C32GA2-RS5W	F5-6600J4040F32GX4-RS5W	F5-5600J4040C32GX2-RS5W
F5-6400J4040G32GA4-RS5W	F5-5400J4040C32GA2-RS5W	F5-6666J4040P32GX4-RS5W	F5-6000J3636F32GX2-RS5W
F5-6600J3636F32GA4-RS5W	F5-5600J3636C32GA2-RS5W	F5-6800J4040G32GX4-RS5W	F5-6000J4040F32GX2-RS5W
F5-6600J4040F32GA4-RS5W	F5-5600J4040C32GA2-RS5W	F5-6800J4242G32GX4-RS5W	F5-6200J3636F32GX2-RS5W
F5-6666J4040P32GA4-RS5W	F5-6000J3636F32GA2-RS5W	F5-4800J3636A32GX1-RS5W	F5-6200J4040F32GX2-RS5W
F5-6800J4040G32GA4-RS5W	F5-6000J4040F32GA2-RS5W	F5-4800J4040A32GX1-RS5W	F5-6400J3636G32GX2-RS5W
F5-6800J4242G32GA4-RS5W	F5-6200J3636F32GA2-RS5W	F5-5200J3636C32GX1-RS5W	F5-6400J4040G32GX2-RS5W
F5-4800J3636A32GA1-RS5W	F5-6200J4040F32GA2-RS5W	F5-5200J4040A32GX1-RS5W	F5-6600J3636F32GX2-RS5W
F5-4800J4040A32GA1-RS5W	F5-6400J3636G32GA2-RS5W	F5-5400J3636C32GX1-RS5W	F5-6600J4040F32GX2-RS5W
F5-5200J3636C32GA1-RS5W	F5-6400J4040G32GA2-RS5W	F5-5400J4040C32GX1-RS5W	F5-6666J4040P32GX2-RS5W
F5-5200J4040A32GA1-RS5W	F5-6600J3636F32GA2-RS5W	F5-5600J3636C32GX1-RS5W	F5-6800J4040G32GX2-RS5W
F5-5400J3636C32GA1-RS5W	F5-6600J4040F32GA2-RS5W	F5-5600J4040C32GX1-RS5W	F5-6800J4242G32GX2-RS5W
F5-5400J4040C32GA1-RS5W	F5-6666J4040P32GA2-RS5W	F5-6000J3636F32GX1-RS5W	F5-4800J3636A16GA4-RS5W
F5-5600J3636C32GA1-RS5W	F5-6800J4040G32GA2-RS5W	F5-6000J4040F32GX1-RS5W	F5-4800J4040A16GA4-RS5W
F5-5600J4040C32GA1-RS5W	F5-6800J4242G32GA2-RS5W	F5-6200J3636F32GX1-RS5W	F5-5200J3636C16GA4-RS5W
F5-6000J3636F32GA1-RS5W	F5-4800J3636A32GX4-RS5W	F5-6200J4040F32GX1-RS5W	F5-5200J4040A16GA4-RS5W
F5-6000J4040F32GA1-RS5W	F5-4800J4040A32GX4-RS5W	F5-6400J3636G32GX1-RS5W	F5-5400J3636C16GA4-RS5W
F5-6200J3636F32GA1-RS5W	F5-5200J3636C32GX4-RS5W	F5-6400J4040G32GX1-RS5W	F5-5400J4040C16GA4-RS5W

Ripjaws S5



F5-5600J3636C16GA4-RS5W	F5-6800J4040G16GA1-RS5W	F5-6000J3636F16GX4-RS5W	F5-4800J3636A16GX2-RS5W
F5-5600J4040C16GA4-RS5W	F5-6800J4242G16GA1-RS5W	F5-6000J4040F16GX4-RS5W	F5-4800J4040A16GX2-RS5W
F5-6000J3636F16GA4-RS5W	F5-4800J3636A16GA2-RS5W	F5-6200J3636F16GX4-RS5W	F5-5200J3636C16GX2-RS5W
F5-6000J4040F16GA4-RS5W	F5-4800J4040A16GA2-RS5W	F5-6200J4040F16GX4-RS5W	F5-5200J4040A16GX2-RS5W
F5-6200J3636F16GA4-RS5W	F5-5200J3636C16GA2-RS5W	F5-6400J3636G16GX4-RS5W	F5-5400J3636C16GX2-RS5W
F5-6200J4040F16GA4-RS5W	F5-5200J4040A16GA2-RS5W	F5-6400J4040G16GX4-RS5W	F5-5400J4040C16GX2-RS5W
F5-6400J3636G16GA4-RS5W	F5-5400J3636C16GA2-RS5W	F5-6600J3636F16GX4-RS5W	F5-5600J3636C16GX2-RS5W
F5-6400J4040G16GA4-RS5W	F5-5400J4040C16GA2-RS5W	F5-6600J4040F16GX4-RS5W	F5-5600J4040C16GX2-RS5W
F5-6600J3636F16GA4-RS5W	F5-5600J3636C16GA2-RS5W	F5-6666J4040P16GX4-RS5W	F5-6000J3636F16GX2-RS5W
F5-6600J4040F16GA4-RS5W	F5-5600J4040C16GA2-RS5W	F5-6800J4040G16GX4-RS5W	F5-6000J4040F16GX2-RS5W
F5-6666J4040P16GA4-RS5W	F5-6000J3636F16GA2-RS5W	F5-6800J4242G16GX4-RS5W	F5-6200J3636F16GX2-RS5W
F5-6800J4040G16GA4-RS5W	F5-6000J4040F16GA2-RS5W	F5-4800J3636A16GX1-RS5W	F5-6200J4040F16GX2-RS5W
F5-6800J4242G16GA4-RS5W	F5-6200J3636F16GA2-RS5W	F5-4800J4040A16GX1-RS5W	F5-6400J3636G16GX2-RS5W
F5-4800J3636A16GA1-RS5W	F5-6200J4040F16GA2-RS5W	F5-5200J3636C16GX1-RS5W	F5-6400J4040G16GX2-RS5W
F5-4800J4040A16GA1-RS5W	F5-6400J3636G16GA2-RS5W	F5-5200J4040A16GX1-RS5W	F5-6600J3636F16GX2-RS5W
F5-5200J3636C16GA1-RS5W	F5-6400J4040G16GA2-RS5W	F5-5400J3636C16GX1-RS5W	F5-6600J4040F16GX2-RS5W
F5-5200J4040A16GA1-RS5W	F5-6600J3636F16GA2-RS5W	F5-5400J4040C16GX1-RS5W	F5-6666J4040P16GX2-RS5W
F5-5400J3636C16GA1-RS5W	F5-6600J4040F16GA2-RS5W	F5-5600J3636C16GX1-RS5W	F5-6800J4040G16GX2-RS5W
F5-5400J4040C16GA1-RS5W	F5-6666J4040P16GA2-RS5W	F5-5600J4040C16GX1-RS5W	F5-6800J4242G16GX2-RS5W
F5-5600J3636C16GA1-RS5W	F5-6800J4040G16GA2-RS5W	F5-6000J3636F16GX1-RS5W	
F5-5600J4040C16GA1-RS5W	F5-6800J4242G16GA2-RS5W	F5-6000J4040F16GX1-RS5W	
F5-6000J3636F16GA1-RS5W	F5-4800J3636A16GX4-RS5W	F5-6200J3636F16GX1-RS5W	
F5-6000J4040F16GA1-RS5W	F5-4800J4040A16GX4-RS5W	F5-6200J4040F16GX1-RS5W	
F5-6200J3636F16GA1-RS5W	F5-5200J3636C16GX4-RS5W	F5-6400J3636G16GX1-RS5W	
F5-6200J4040F16GA1-RS5W	F5-5200J4040D16GX4-RS5W	F5-6400J4040G16GX1-RS5W	
F5-6400J3636G16GA1-RS5W	F5-5200J4040A16GX4-RS5W	F5-6600J3636F16GX1-RS5W	
F5-6400J4040G16GA1-RS5W	F5-5400J3636C16GX4-RS5W	F5-6600J4040F16GX1-RS5W	
F5-6600J3636F16GA1-RS5W	F5-5400J4040C16GX4-RS5W	F5-6666J4040P16GX1-RS5W	
F5-6600J4040F16GA1-RS5W	F5-5600J3636C16GX4-RS5W	F5-6800J4040G16GX1-RS5W	
F5-6666J4040P16GA1-RS5W	F5-5600J4040C16GX4-RS5W	F5-6800J4242G16GX1-RS5W	

Trident Z5



F5-4800U3636A32GA4-TZ5S	F5-6200U4040F32GA1-TZ5S	F5-5200U4040A32GX4-TZ5S	F5-6600U3636F32GX1-TZ5S
F5-4800U4040A32GA4-TZ5S	F5-6400U3636F32GA1-TZ5S	F5-5400U3636C32GX4-TZ5S	F5-6600U4040F32GX1-TZ5S
F5-5200U3636C32GA4-TZ5S	F5-6400U4040F32GA1-TZ5S	F5-5400U4040C32GX4-TZ5S	F5-6666U4040P32GX1-TZ5S
F5-5200U4040A32GA4-TZ5S	F5-6600U3636F32GA1-TZ5S	F5-5600U3636C32GX4-TZ5S	F5-6800U4040G32GX1-TZ5S
F5-5400U3636C32GA4-TZ5S	F5-6600U4040F32GA1-TZ5S	F5-5600U4040C32GX4-TZ5S	F5-6800U4242G32GX1-TZ5S
F5-5400U4040C32GA4-TZ5S	F5-6666U4040P32GA1-TZ5S	F5-6000U3636E32GX4-TZ5S	F5-4800U3636A32GX2-TZ5S
F5-5600U3636C32GA4-TZ5S	F5-6800U4040G32GA1-TZ5S	F5-6000U4040E32GX4-TZ5S	F5-4800U4040A32GX2-TZ5S
F5-5600U4040C32GA4-TZ5S	F5-6800U4242G32GA1-TZ5S	F5-6200U3636F32GX4-TZ5S	F5-5200U3636C32GX2-TZ5S
F5-6000U3636E32GA4-TZ5S	F5-4800U3636A32GA2-TZ5S	F5-6200U4040F32GX4-TZ5S	F5-5200U4040A32GX2-TZ5S
F5-6000U4040E32GA4-TZ5S	F5-4800U4040A32GA2-TZ5S	F5-6400U3636F32GX4-TZ5S	F5-5400U3636C32GX2-TZ5S
F5-6200U3636F32GA4-TZ5S	F5-5200U3636C32GA2-TZ5S	F5-6400U4040F32GX4-TZ5S	F5-5400U4040C32GX2-TZ5S
F5-6200U4040F32GA4-TZ5S	F5-5200U4040A32GA2-TZ5S	F5-6600U3636F32GX4-TZ5S	F5-5600U3636C32GX2-TZ5S
F5-6400U3636F32GA4-TZ5S	F5-5400U3636C32GA2-TZ5S	F5-6600U4040F32GX4-TZ5S	F5-5600U4040C32GX2-TZ5S
F5-6400U4040F32GA4-TZ5S	F5-5400U4040C32GA2-TZ5S	F5-6666U4040P32GX4-TZ5S	F5-6000U3636E32GX2-TZ5S
F5-6600U3636F32GA4-TZ5S	F5-5600U3636C32GA2-TZ5S	F5-6800U4040G32GX4-TZ5S	F5-6000U4040E32GX2-TZ5S
F5-6600U4040F32GA4-TZ5S	F5-5600U4040C32GA2-TZ5S	F5-6800U4242G32GX4-TZ5S	F5-6200U3636F32GX2-TZ5S
F5-6666U4040P32GA4-TZ5S	F5-6000U3636E32GA2-TZ5S	F5-4800U3636A32GX1-TZ5S	F5-6200U4040F32GX2-TZ5S
F5-6800U4040G32GA4-TZ5S	F5-6000U4040E32GA2-TZ5S	F5-4800U4040A32GX1-TZ5S	F5-6400U3636F32GX2-TZ5S
F5-6800U4242G32GA4-TZ5S	F5-6200U3636F32GA2-TZ5S	F5-5200U3636C32GX1-TZ5S	F5-6400U4040F32GX2-TZ5S
F5-4800U3636A32GA1-TZ5S	F5-6200U4040F32GA2-TZ5S	F5-5200U4040A32GX1-TZ5S	F5-6600U3636F32GX2-TZ5S
F5-4800U4040A32GA1-TZ5S	F5-6400U3636F32GA2-TZ5S	F5-5400U3636C32GX1-TZ5S	F5-6600U4040F32GX2-TZ5S
F5-5200U3636C32GA1-TZ5S	F5-6400U4040F32GA2-TZ5S	F5-5400U4040C32GX1-TZ5S	F5-6666U4040P32GX2-TZ5S
F5-5200U4040A32GA1-TZ5S	F5-6600U3636F32GA2-TZ5S	F5-5600U3636C32GX1-TZ5S	F5-6800U4040G32GX2-TZ5S
F5-5400U3636C32GA1-TZ5S	F5-6600U4040F32GA2-TZ5S	F5-5600U4040C32GX1-TZ5S	F5-6800U4242G32GX2-TZ5S
F5-5400U4040C32GA1-TZ5S	F5-6666U4040P32GA2-TZ5S	F5-6000U3636E32GX1-TZ5S	F5-4800U3636A16GA4-TZ5S
F5-5600U3636C32GA1-TZ5S	F5-6800U4040G32GA2-TZ5S	F5-6000U4040E32GX1-TZ5S	F5-4800U4040A16GA4-TZ5S
F5-5600U4040C32GA1-TZ5S	F5-6800U4242G32GA2-TZ5S	F5-6200U3636F32GX1-TZ5S	F5-5200U3636C16GA4-TZ5S
F5-6000U3636E32GA1-TZ5S	F5-4800U3636A32GX4-TZ5S	F5-6200U4040F32GX1-TZ5S	F5-5200U4040A16GA4-TZ5S
F5-6000U4040E32GA1-TZ5S	F5-4800U4040A32GX4-TZ5S	F5-6400U3636F32GX1-TZ5S	F5-5400U3636C16GA4-TZ5S
F5-6200U3636F32GA1-TZ5S	F5-5200U3636C32GX4-TZ5S	F5-6400U4040F32GX1-TZ5S	F5-5400U4040C16GA4-TZ5S

Trident Z5



F5-5600U3636C16GA4-TZ5S	F5-6800U4040G16GA1-TZ5S	F5-6000U3636E16GX4-TZ5S	F5-4800U3636A16GX2-TZ5S
F5-5600U4040C16GA4-TZ5S	F5-6800U4242G16GA1-TZ5S	F5-6000U4040E16GX4-TZ5S	F5-4800U4040A16GX2-TZ5S
F5-6000U3636E16GA4-TZ5S	F5-4800U3636A16GA2-TZ5S	F5-6200U3636F16GX4-TZ5S	F5-5200U3636C16GX2-TZ5S
F5-6000U4040E16GA4-TZ5S	F5-4800U4040A16GA2-TZ5S	F5-6200U4040F16GX4-TZ5S	F5-5200U4040A16GX2-TZ5S
F5-6200U3636F16GA4-TZ5S	F5-5200U3636C16GA2-TZ5S	F5-6400U3636F16GX4-TZ5S	F5-5400U3636C16GX2-TZ5S
F5-6200U4040F16GA4-TZ5S	F5-5200U4040A16GA2-TZ5S	F5-6400U4040F16GX4-TZ5S	F5-5400U4040C16GX2-TZ5S
F5-6400U3636F16GA4-TZ5S	F5-5400U3636C16GA2-TZ5S	F5-6600U3636F16GX4-TZ5S	F5-5600U3636C16GX2-TZ5S
F5-6400U4040F16GA4-TZ5S	F5-5400U4040C16GA2-TZ5S	F5-6600U4040F16GX4-TZ5S	F5-5600U4040C16GX2-TZ5S
F5-6600U3636F16GA4-TZ5S	F5-5600U3636C16GA2-TZ5S	F5-6666U4040P16GX4-TZ5S	F5-6000U3636E16GX2-TZ5S
F5-6600U4040F16GA4-TZ5S	F5-5600U4040C16GA2-TZ5S	F5-6800U4040G16GX4-TZ5S	F5-6000U4040E16GX2-TZ5S
F5-6666U4040P16GA4-TZ5S	F5-6000U3636E16GA2-TZ5S	F5-6800U4242G16GX4-TZ5S	F5-6200U3636F16GX2-TZ5S
F5-6800U4040G16GA4-TZ5S	F5-6000U4040E16GA2-TZ5S	F5-4800U3636A16GX1-TZ5S	F5-6200U4040F16GX2-TZ5S
F5-6800U4242G16GA4-TZ5S	F5-6200U3636F16GA2-TZ5S	F5-4800U4040A16GX1-TZ5S	F5-6400U3636F16GX2-TZ5S
F5-4800U3636A16GA1-TZ5S	F5-6200U4040F16GA2-TZ5S	F5-5200U3636C16GX1-TZ5S	F5-6400U4040F16GX2-TZ5S
F5-4800U4040A16GA1-TZ5S	F5-6400U3636F16GA2-TZ5S	F5-5200U4040A16GX1-TZ5S	F5-6600U3636F16GX2-TZ5S
F5-5200U3636C16GA1-TZ5S	F5-6400U4040F16GA2-TZ5S	F5-5400U3636C16GX1-TZ5S	F5-6600U4040F16GX2-TZ5S
F5-5200U4040A16GA1-TZ5S	F5-6600U3636F16GA2-TZ5S	F5-5400U4040C16GX1-TZ5S	F5-6666U4040P16GX2-TZ5S
F5-5400U3636C16GA1-TZ5S	F5-6600U4040F16GA2-TZ5S	F5-5600U3636C16GX1-TZ5S	F5-6800U4040G16GX2-TZ5S
F5-5400U4040C16GA1-TZ5S	F5-6666U4040P16GA2-TZ5S	F5-5600U4040C16GX1-TZ5S	F5-6800U4242G16GX2-TZ5S
F5-5600U3636C16GA1-TZ5S	F5-6800U4040G16GA2-TZ5S	F5-6000U3636E16GX1-TZ5S	
F5-5600U4040C16GA1-TZ5S	F5-6800U4242G16GA2-TZ5S	F5-6000U4040E16GX1-TZ5S	
F5-6000U3636E16GA1-TZ5S	F5-4800U3636A16GX4-TZ5S	F5-6200U3636F16GX1-TZ5S	
F5-6000U4040E16GA1-TZ5S	F5-4800U4040A16GX4-TZ5S	F5-6200U4040F16GX1-TZ5S	
F5-6200U3636F16GA1-TZ5S	F5-5200U3636C16GX4-TZ5S	F5-6400U3636F16GX1-TZ5S	
F5-6200U4040F16GA1-TZ5S	F5-5200U4040D16GX4-TZ5S	F5-6400U4040F16GX1-TZ5S	
F5-6400U3636F16GA1-TZ5S	F5-5200U4040A16GX4-TZ5S	F5-6600U3636F16GX1-TZ5S	
F5-6400U4040F16GA1-TZ5S	F5-5400U3636C16GX4-TZ5S	F5-6600U4040F16GX1-TZ5S	
F5-6600U3636F16GA1-TZ5S	F5-5400U4040C16GX4-TZ5S	F5-6666U4040P16GX1-TZ5S	
F5-6600U4040F16GA1-TZ5S	F5-5600U3636C16GX4-TZ5S	F5-6800U4040G16GX1-TZ5S	
F5-6666U4040P16GA1-TZ5S	F5-5600U4040C16GX4-TZ5S	F5-6800U4242G16GX1-TZ5S	

Trident Z5



F5-4800J3636A32GA4-TZ5S	F5-6200J4040F32GA1-TZ5S	F5-5200J4040A32GX4-TZ5S	F5-6600J3636F32GX1-TZ5S
F5-4800J4040A32GA4-TZ5S	F5-6400J3636G32GA1-TZ5S	F5-5400J3636C32GX4-TZ5S	F5-6600J4040F32GX1-TZ5S
F5-5200J3636C32GA4-TZ5S	F5-6400J4040G32GA1-TZ5S	F5-5400J4040C32GX4-TZ5S	F5-6666J4040P32GX1-TZ5S
F5-5200J4040A32GA4-TZ5S	F5-6600J3636F32GA1-TZ5S	F5-5600J3636C32GX4-TZ5S	F5-6800J4040G32GX1-TZ5S
F5-5400J3636C32GA4-TZ5S	F5-6600J4040F32GA1-TZ5S	F5-5600J4040C32GX4-TZ5S	F5-6800J4242G32GX1-TZ5S
F5-5400J4040C32GA4-TZ5S	F5-6666J4040P32GA1-TZ5S	F5-6000J3636F32GX4-TZ5S	F5-4800J3636A32GX2-TZ5S
F5-5600J3636C32GA4-TZ5S	F5-6800J4040G32GA1-TZ5S	F5-6000J4040F32GX4-TZ5S	F5-4800J4040A32GX2-TZ5S
F5-5600J4040C32GA4-TZ5S	F5-6800J4242G32GA1-TZ5S	F5-6200J3636F32GX4-TZ5S	F5-5200J3636C32GX2-TZ5S
F5-6000J3636F32GA4-TZ5S	F5-4800J3636A32GA2-TZ5S	F5-6200J4040F32GX4-TZ5S	F5-5200J4040A32GX2-TZ5S
F5-6000J4040F32GA4-TZ5S	F5-4800J4040A32GA2-TZ5S	F5-6400J3636G32GX4-TZ5S	F5-5400J3636C32GX2-TZ5S
F5-6200J3636F32GA4-TZ5S	F5-5200J3636C32GA2-TZ5S	F5-6400J4040G32GX4-TZ5S	F5-5400J4040C32GX2-TZ5S
F5-6200J4040F32GA4-TZ5S	F5-5200J4040A32GA2-TZ5S	F5-6600J3636F32GX4-TZ5S	F5-5600J3636C32GX2-TZ5S
F5-6400J3636G32GA4-TZ5S	F5-5400J3636C32GA2-TZ5S	F5-6600J4040F32GX4-TZ5S	F5-5600J4040C32GX2-TZ5S
F5-6400J4040G32GA4-TZ5S	F5-5400J4040C32GA2-TZ5S	F5-6666J4040P32GX4-TZ5S	F5-6000J3636F32GX2-TZ5S
F5-6600J3636F32GA4-TZ5S	F5-5600J3636C32GA2-TZ5S	F5-6800J4040G32GX4-TZ5S	F5-6000J4040F32GX2-TZ5S
F5-6600J4040F32GA4-TZ5S	F5-5600J4040C32GA2-TZ5S	F5-6800J4242G32GX4-TZ5S	F5-6200J3636F32GX2-TZ5S
F5-6666J4040P32GA4-TZ5S	F5-6000J3636F32GA2-TZ5S	F5-4800J3636A32GX1-TZ5S	F5-6200J4040F32GX2-TZ5S
F5-6800J4040G32GA4-TZ5S	F5-6000J4040F32GA2-TZ5S	F5-4800J4040A32GX1-TZ5S	F5-6400J3636G32GX2-TZ5S
F5-6800J4242G32GA4-TZ5S	F5-6200J3636F32GA2-TZ5S	F5-5200J3636C32GX1-TZ5S	F5-6400J4040G32GX2-TZ5S
F5-4800J3636A32GA1-TZ5S	F5-6200J4040F32GA2-TZ5S	F5-5200J4040A32GX1-TZ5S	F5-6600J3636F32GX2-TZ5S
F5-4800J4040A32GA1-TZ5S	F5-6400J3636G32GA2-TZ5S	F5-5400J3636C32GX1-TZ5S	F5-6600J4040F32GX2-TZ5S
F5-5200J3636C32GA1-TZ5S	F5-6400J4040G32GA2-TZ5S	F5-5400J4040C32GX1-TZ5S	F5-6666J4040P32GX2-TZ5S
F5-5200J4040A32GA1-TZ5S	F5-6600J3636F32GA2-TZ5S	F5-5600J3636C32GX1-TZ5S	F5-6800J4040G32GX2-TZ5S
F5-5400J3636C32GA1-TZ5S	F5-6600J4040F32GA2-TZ5S	F5-5600J4040C32GX1-TZ5S	F5-6800J4242G32GX2-TZ5S
F5-5400J4040C32GA1-TZ5S	F5-6666J4040P32GA2-TZ5S	F5-6000J3636F32GX1-TZ5S	F5-4800J3636A16GA4-TZ5S
F5-5600J3636C32GA1-TZ5S	F5-6800J4040G32GA2-TZ5S	F5-6000J4040F32GX1-TZ5S	F5-4800J4040A16GA4-TZ5S
F5-5600J4040C32GA1-TZ5S	F5-6800J4242G32GA2-TZ5S	F5-6200J3636F32GX1-TZ5S	F5-5200J3636C16GA4-TZ5S
F5-6000J3636F32GA1-TZ5S	F5-4800J3636A32GX4-TZ5S	F5-6200J4040F32GX1-TZ5S	F5-5200J4040A16GA4-TZ5S
F5-6000J4040F32GA1-TZ5S	F5-4800J4040A32GX4-TZ5S	F5-6400J3636G32GX1-TZ5S	F5-5400J3636C16GA4-TZ5S
F5-6200J3636F32GA1-TZ5S	F5-5200J3636C32GX4-TZ5S	F5-6400J4040G32GX1-TZ5S	F5-5400J4040C16GA4-TZ5S

Trident Z5



F5-5600J3636C16GA4-TZ5S	F5-6800J4040G16GA1-TZ5S	F5-6000J3636F16GX4-TZ5S	F5-4800J3636A16GX2-TZ5S
F5-5600J4040C16GA4-TZ5S	F5-6800J4242G16GA1-TZ5S	F5-6000J4040F16GX4-TZ5S	F5-4800J4040A16GX2-TZ5S
F5-6000J3636F16GA4-TZ5S	F5-4800J3636A16GA2-TZ5S	F5-6200J3636F16GX4-TZ5S	F5-5200J3636C16GX2-TZ5S
F5-6000J4040F16GA4-TZ5S	F5-4800J4040A16GA2-TZ5S	F5-6200J4040F16GX4-TZ5S	F5-5200J4040A16GX2-TZ5S
F5-6200J3636F16GA4-TZ5S	F5-5200J3636C16GA2-TZ5S	F5-6400J3636G16GX4-TZ5S	F5-5400J3636C16GX2-TZ5S
F5-6200J4040F16GA4-TZ5S	F5-5200J4040A16GA2-TZ5S	F5-6400J4040G16GX4-TZ5S	F5-5400J4040C16GX2-TZ5S
F5-6400J3636G16GA4-TZ5S	F5-5400J3636C16GA2-TZ5S	F5-6600J3636F16GX4-TZ5S	F5-5600J3636C16GX2-TZ5S
F5-6400J4040G16GA4-TZ5S	F5-5400J4040C16GA2-TZ5S	F5-6600J4040F16GX4-TZ5S	F5-5600J4040C16GX2-TZ5S
F5-6600J3636F16GA4-TZ5S	F5-5600J3636C16GA2-TZ5S	F5-6666J4040P16GX4-TZ5S	F5-6000J3636F16GX2-TZ5S
F5-6600J4040F16GA4-TZ5S	F5-5600J4040C16GA2-TZ5S	F5-6800J4040G16GX4-TZ5S	F5-6000J4040F16GX2-TZ5S
F5-6666J4040P16GA4-TZ5S	F5-6000J3636F16GA2-TZ5S	F5-6800J4242G16GX4-TZ5S	F5-6200J3636F16GX2-TZ5S
F5-6800J4040G16GA4-TZ5S	F5-6000J4040F16GA2-TZ5S	F5-4800J3636A16GX1-TZ5S	F5-6200J4040F16GX2-TZ5S
F5-6800J4242G16GA4-TZ5S	F5-6200J3636F16GA2-TZ5S	F5-4800J4040A16GX1-TZ5S	F5-6400J3636G16GX2-TZ5S
F5-4800J3636A16GA1-TZ5S	F5-6200J4040F16GA2-TZ5S	F5-5200J3636C16GX1-TZ5S	F5-6400J4040G16GX2-TZ5S
F5-4800J4040A16GA1-TZ5S	F5-6400J3636G16GA2-TZ5S	F5-5200J4040A16GX1-TZ5S	F5-6600J3636F16GX2-TZ5S
F5-5200J3636C16GA1-TZ5S	F5-6400J4040G16GA2-TZ5S	F5-5400J3636C16GX1-TZ5S	F5-6600J4040F16GX2-TZ5S
F5-5200J4040A16GA1-TZ5S	F5-6600J3636F16GA2-TZ5S	F5-5400J4040C16GX1-TZ5S	F5-6666J4040P16GX2-TZ5S
F5-5400J3636C16GA1-TZ5S	F5-6600J4040F16GA2-TZ5S	F5-5600J3636C16GX1-TZ5S	F5-6800J4040G16GX2-TZ5S
F5-5400J4040C16GA1-TZ5S	F5-6666J4040P16GA2-TZ5S	F5-5600J4040C16GX1-TZ5S	F5-6800J4242G16GX2-TZ5S
F5-5600J3636C16GA1-TZ5S	F5-6800J4040G16GA2-TZ5S	F5-6000J3636F16GX1-TZ5S	
F5-5600J4040C16GA1-TZ5S	F5-6800J4242G16GA2-TZ5S	F5-6000J4040F16GX1-TZ5S	
F5-6000J3636F16GA1-TZ5S	F5-4800J3636A16GX4-TZ5S	F5-6200J3636F16GX1-TZ5S	
F5-6000J4040F16GA1-TZ5S	F5-4800J4040A16GX4-TZ5S	F5-6200J4040F16GX1-TZ5S	
F5-6200J3636F16GA1-TZ5S	F5-5200J3636C16GX4-TZ5S	F5-6400J3636G16GX1-TZ5S	
F5-6200J4040F16GA1-TZ5S	F5-5200J4040D16GX4-TZ5S	F5-6400J4040G16GX1-TZ5S	
F5-6400J3636G16GA1-TZ5S	F5-5200J4040A16GX4-TZ5S	F5-6600J3636F16GX1-TZ5S	
F5-6400J4040G16GA1-TZ5S	F5-5400J3636C16GX4-TZ5S	F5-6600J4040F16GX1-TZ5S	
F5-6600J3636F16GA1-TZ5S	F5-5400J4040C16GX4-TZ5S	F5-6666J4040P16GX1-TZ5S	
F5-6600J4040F16GA1-TZ5S	F5-5600J3636C16GX4-TZ5S	F5-6800J4040G16GX1-TZ5S	
F5-6666J4040P16GA1-TZ5S	F5-5600J4040C16GX4-TZ5S	F5-6800J4242G16GX1-TZ5S	

Trident Z5



F5-4800U3636A32GA4-TZ5K	F5-6200U4040F32GA1-TZ5K	F5-5200U4040A32GX4-TZ5K	F5-6600U3636F32GX1-TZ5K
F5-4800U4040A32GA4-TZ5K	F5-6400U3636F32GA1-TZ5K	F5-5400U3636C32GX4-TZ5K	F5-6600U4040F32GX1-TZ5K
F5-5200U3636C32GA4-TZ5K	F5-6400U4040F32GA1-TZ5K	F5-5400U4040C32GX4-TZ5K	F5-6666U4040P32GX1-TZ5K
F5-5200U4040A32GA4-TZ5K	F5-6600U3636F32GA1-TZ5K	F5-5600U3636C32GX4-TZ5K	F5-6800U4040G32GX1-TZ5K
F5-5400U3636C32GA4-TZ5K	F5-6600U4040F32GA1-TZ5K	F5-5600U4040C32GX4-TZ5K	F5-6800U4242G32GX1-TZ5K
F5-5400U4040C32GA4-TZ5K	F5-6666U4040P32GA1-TZ5K	F5-6000U3636E32GX4-TZ5K	F5-4800U3636A32GX2-TZ5K
F5-5600U3636C32GA4-TZ5K	F5-6800U4040G32GA1-TZ5K	F5-6000U4040E32GX4-TZ5K	F5-4800U4040A32GX2-TZ5K
F5-5600U4040C32GA4-TZ5K	F5-6800U4242G32GA1-TZ5K	F5-6200U3636F32GX4-TZ5K	F5-5200U3636C32GX2-TZ5K
F5-6000U3636E32GA4-TZ5K	F5-4800U3636A32GA2-TZ5K	F5-6200U4040F32GX4-TZ5K	F5-5200U4040A32GX2-TZ5K
F5-6000U4040E32GA4-TZ5K	F5-4800U4040A32GA2-TZ5K	F5-6400U3636F32GX4-TZ5K	F5-5400U3636C32GX2-TZ5K
F5-6200U3636F32GA4-TZ5K	F5-5200U3636C32GA2-TZ5K	F5-6400U4040F32GX4-TZ5K	F5-5400U4040C32GX2-TZ5K
F5-6200U4040F32GA4-TZ5K	F5-5200U4040A32GA2-TZ5K	F5-6600U3636F32GX4-TZ5K	F5-5600U3636C32GX2-TZ5K
F5-6400U3636F32GA4-TZ5K	F5-5400U3636C32GA2-TZ5K	F5-6600U4040F32GX4-TZ5K	F5-5600U4040C32GX2-TZ5K
F5-6400U4040F32GA4-TZ5K	F5-5400U4040C32GA2-TZ5K	F5-6666U4040P32GX4-TZ5K	F5-6000U3636E32GX2-TZ5K
F5-6600U3636F32GA4-TZ5K	F5-5600U3636C32GA2-TZ5K	F5-6800U4040G32GX4-TZ5K	F5-6000U4040E32GX2-TZ5K
F5-6600U4040F32GA4-TZ5K	F5-5600U4040C32GA2-TZ5K	F5-6800U4242G32GX4-TZ5K	F5-6200U3636F32GX2-TZ5K
F5-6666U4040P32GA4-TZ5K	F5-6000U3636E32GA2-TZ5K	F5-4800U3636A32GX1-TZ5K	F5-6200U4040F32GX2-TZ5K
F5-6800U4040G32GA4-TZ5K	F5-6000U4040E32GA2-TZ5K	F5-4800U4040A32GX1-TZ5K	F5-6400U3636F32GX2-TZ5K
F5-6800U4242G32GA4-TZ5K	F5-6200U3636F32GA2-TZ5K	F5-5200U3636C32GX1-TZ5K	F5-6400U4040F32GX2-TZ5K
F5-4800U3636A32GA1-TZ5K	F5-6200U4040F32GA2-TZ5K	F5-5200U4040A32GX1-TZ5K	F5-6600U3636F32GX2-TZ5K
F5-4800U4040A32GA1-TZ5K	F5-6400U3636F32GA2-TZ5K	F5-5400U3636C32GX1-TZ5K	F5-6600U4040F32GX2-TZ5K
F5-5200U3636C32GA1-TZ5K	F5-6400U4040F32GA2-TZ5K	F5-5400U4040C32GX1-TZ5K	F5-6666U4040P32GX2-TZ5K
F5-5200U4040A32GA1-TZ5K	F5-6600U3636F32GA2-TZ5K	F5-5600U3636C32GX1-TZ5K	F5-6800U4040G32GX2-TZ5K
F5-5400U3636C32GA1-TZ5K	F5-6600U4040F32GA2-TZ5K	F5-5600U4040C32GX1-TZ5K	F5-6800U4242G32GX2-TZ5K
F5-5400U4040C32GA1-TZ5K	F5-6666U4040P32GA2-TZ5K	F5-6000U3636E32GX1-TZ5K	F5-4800U3636A16GA4-TZ5K
F5-5600U3636C32GA1-TZ5K	F5-6800U4040G32GA2-TZ5K	F5-6000U4040E32GX1-TZ5K	F5-4800U4040A16GA4-TZ5K
F5-5600U4040C32GA1-TZ5K	F5-6800U4242G32GA2-TZ5K	F5-6200U3636F32GX1-TZ5K	F5-5200U3636C16GA4-TZ5K
F5-6000U3636E32GA1-TZ5K	F5-4800U3636A32GX4-TZ5K	F5-6200U4040F32GX1-TZ5K	F5-5200U4040A16GA4-TZ5K
F5-6000U4040E32GA1-TZ5K	F5-4800U4040A32GX4-TZ5K	F5-6400U3636F32GX1-TZ5K	F5-5400U3636C16GA4-TZ5K
F5-6200U3636F32GA1-TZ5K	F5-5200U3636C32GX4-TZ5K	F5-6400U4040F32GX1-TZ5K	F5-5400U4040C16GA4-TZ5K

Trident Z5



F5-5600U3636C16GA4-TZ5K	F5-6800U4040G16GA1-TZ5K	F5-6000U3636E16GX4-TZ5K	F5-4800U3636A16GX2-TZ5K
F5-5600U4040C16GA4-TZ5K	F5-6800U4242G16GA1-TZ5K	F5-6000U4040E16GX4-TZ5K	F5-4800U4040A16GX2-TZ5K
F5-6000U3636E16GA4-TZ5K	F5-4800U3636A16GA2-TZ5K	F5-6200U3636F16GX4-TZ5K	F5-5200U3636C16GX2-TZ5K
F5-6000U4040E16GA4-TZ5K	F5-4800U4040A16GA2-TZ5K	F5-6200U4040F16GX4-TZ5K	F5-5200U4040A16GX2-TZ5K
F5-6200U3636F16GA4-TZ5K	F5-5200U3636C16GA2-TZ5K	F5-6400U3636F16GX4-TZ5K	F5-5400U3636C16GX2-TZ5K
F5-6200U4040F16GA4-TZ5K	F5-5200U4040A16GA2-TZ5K	F5-6400U4040F16GX4-TZ5K	F5-5400U4040C16GX2-TZ5K
F5-6400U3636F16GA4-TZ5K	F5-5400U3636C16GA2-TZ5K	F5-6600U3636F16GX4-TZ5K	F5-5600U3636C16GX2-TZ5K
F5-6400U4040F16GA4-TZ5K	F5-5400U4040C16GA2-TZ5K	F5-6600U4040F16GX4-TZ5K	F5-5600U4040C16GX2-TZ5K
F5-6600U3636F16GA4-TZ5K	F5-5600U3636C16GA2-TZ5K	F5-6666U4040P16GX4-TZ5K	F5-6000U3636E16GX2-TZ5K
F5-6600U4040F16GA4-TZ5K	F5-5600U4040C16GA2-TZ5K	F5-6800U4040G16GX4-TZ5K	F5-6000U4040E16GX2-TZ5K
F5-6666U4040P16GA4-TZ5K	F5-6000U3636E16GA2-TZ5K	F5-6800U4242G16GX4-TZ5K	F5-6200U3636F16GX2-TZ5K
F5-6800U4040G16GA4-TZ5K	F5-6000U4040E16GA2-TZ5K	F5-4800U3636A16GX1-TZ5K	F5-6200U4040F16GX2-TZ5K
F5-6800U4242G16GA4-TZ5K	F5-6200U3636F16GA2-TZ5K	F5-4800U4040A16GX1-TZ5K	F5-6400U3636F16GX2-TZ5K
F5-4800U3636A16GA1-TZ5K	F5-6200U4040F16GA2-TZ5K	F5-5200U3636C16GX1-TZ5K	F5-6400U4040F16GX2-TZ5K
F5-4800U4040A16GA1-TZ5K	F5-6400U3636F16GA2-TZ5K	F5-5200U4040A16GX1-TZ5K	F5-6600U3636F16GX2-TZ5K
F5-5200U3636C16GA1-TZ5K	F5-6400U4040F16GA2-TZ5K	F5-5400U3636C16GX1-TZ5K	F5-6600U4040F16GX2-TZ5K
F5-5200U4040A16GA1-TZ5K	F5-6600U3636F16GA2-TZ5K	F5-5400U4040C16GX1-TZ5K	F5-6666U4040P16GX2-TZ5K
F5-5400U3636C16GA1-TZ5K	F5-6600U4040F16GA2-TZ5K	F5-5600U3636C16GX1-TZ5K	F5-6800U4040G16GX2-TZ5K
F5-5400U4040C16GA1-TZ5K	F5-6666U4040P16GA2-TZ5K	F5-5600U4040C16GX1-TZ5K	F5-6800U4242G16GX2-TZ5K
F5-5600U3636C16GA1-TZ5K	F5-6800U4040G16GA2-TZ5K	F5-6000U3636E16GX1-TZ5K	
F5-5600U4040C16GA1-TZ5K	F5-6800U4242G16GA2-TZ5K	F5-6000U4040E16GX1-TZ5K	
F5-6000U3636E16GA1-TZ5K	F5-4800U3636A16GX4-TZ5K	F5-6200U3636F16GX1-TZ5K	
F5-6000U4040E16GA1-TZ5K	F5-4800U4040A16GX4-TZ5K	F5-6200U4040F16GX1-TZ5K	
F5-6200U3636F16GA1-TZ5K	F5-5200U3636C16GX4-TZ5K	F5-6400U3636F16GX1-TZ5K	
F5-6200U4040F16GA1-TZ5K	F5-5200U4040D16GX4-TZ5K	F5-6400U4040F16GX1-TZ5K	
F5-6400U3636F16GA1-TZ5K	F5-5200U4040A16GX4-TZ5K	F5-6600U3636F16GX1-TZ5K	
F5-6400U4040F16GA1-TZ5K	F5-5400U3636C16GX4-TZ5K	F5-6600U4040F16GX1-TZ5K	
F5-6600U3636F16GA1-TZ5K	F5-5400U4040C16GX4-TZ5K	F5-6666U4040P16GX1-TZ5K	
F5-6600U4040F16GA1-TZ5K	F5-5600U3636C16GX4-TZ5K	F5-6800U4040G16GX1-TZ5K	
F5-6666U4040P16GA1-TZ5K	F5-5600U4040C16GX4-TZ5K	F5-6800U4242G16GX1-TZ5K	

Trident Z5



F5-4800J3636A32GA4-TZ5K	F5-6200J4040F32GA1-TZ5K	F5-5200J4040A32GX4-TZ5K	F5-6600J3636F32GX1-TZ5K
F5-4800J4040A32GA4-TZ5K	F5-6400J3636G32GA1-TZ5K	F5-5400J3636C32GX4-TZ5K	F5-6600J4040F32GX1-TZ5K
F5-5200J3636C32GA4-TZ5K	F5-6400J4040G32GA1-TZ5K	F5-5400J4040C32GX4-TZ5K	F5-6666J4040P32GX1-TZ5K
F5-5200J4040A32GA4-TZ5K	F5-6600J3636F32GA1-TZ5K	F5-5600J3636C32GX4-TZ5K	F5-6800J4040G32GX1-TZ5K
F5-5400J3636C32GA4-TZ5K	F5-6600J4040F32GA1-TZ5K	F5-5600J4040C32GX4-TZ5K	F5-6800J4242G32GX1-TZ5K
F5-5400J4040C32GA4-TZ5K	F5-6666J4040P32GA1-TZ5K	F5-6000J3636F32GX4-TZ5K	F5-4800J3636A32GX2-TZ5K
F5-5600J3636C32GA4-TZ5K	F5-6800J4040G32GA1-TZ5K	F5-6000J4040F32GX4-TZ5K	F5-4800J4040A32GX2-TZ5K
F5-5600J4040C32GA4-TZ5K	F5-6800J4242G32GA1-TZ5K	F5-6200J3636F32GX4-TZ5K	F5-5200J3636C32GX2-TZ5K
F5-6000J3636F32GA4-TZ5K	F5-4800J3636A32GA2-TZ5K	F5-6200J4040F32GX4-TZ5K	F5-5200J4040A32GX2-TZ5K
F5-6000J4040F32GA4-TZ5K	F5-4800J4040A32GA2-TZ5K	F5-6400J3636G32GX4-TZ5K	F5-5400J3636C32GX2-TZ5K
F5-6200J3636F32GA4-TZ5K	F5-5200J3636C32GA2-TZ5K	F5-6400J4040G32GX4-TZ5K	F5-5400J4040C32GX2-TZ5K
F5-6200J4040F32GA4-TZ5K	F5-5200J4040A32GA2-TZ5K	F5-6600J3636F32GX4-TZ5K	F5-5600J3636C32GX2-TZ5K
F5-6400J3636G32GA4-TZ5K	F5-5400J3636C32GA2-TZ5K	F5-6600J4040F32GX4-TZ5K	F5-5600J4040C32GX2-TZ5K
F5-6400J4040G32GA4-TZ5K	F5-5400J4040C32GA2-TZ5K	F5-6666J4040P32GX4-TZ5K	F5-6000J3636F32GX2-TZ5K
F5-6600J3636F32GA4-TZ5K	F5-5600J3636C32GA2-TZ5K	F5-6800J4040G32GX4-TZ5K	F5-6000J4040F32GX2-TZ5K
F5-6600J4040F32GA4-TZ5K	F5-5600J4040C32GA2-TZ5K	F5-6800J4242G32GX4-TZ5K	F5-6200J3636F32GX2-TZ5K
F5-6666J4040P32GA4-TZ5K	F5-6000J3636F32GA2-TZ5K	F5-4800J3636A32GX1-TZ5K	F5-6200J4040F32GX2-TZ5K
F5-6800J4040G32GA4-TZ5K	F5-6000J4040F32GA2-TZ5K	F5-4800J4040A32GX1-TZ5K	F5-6400J3636G32GX2-TZ5K
F5-6800J4242G32GA4-TZ5K	F5-6200J3636F32GA2-TZ5K	F5-5200J3636C32GX1-TZ5K	F5-6400J4040G32GX2-TZ5K
F5-4800J3636A32GA1-TZ5K	F5-6200J4040F32GA2-TZ5K	F5-5200J4040A32GX1-TZ5K	F5-6600J3636F32GX2-TZ5K
F5-4800J4040A32GA1-TZ5K	F5-6400J3636G32GA2-TZ5K	F5-5400J3636C32GX1-TZ5K	F5-6600J4040F32GX2-TZ5K
F5-5200J3636C32GA1-TZ5K	F5-6400J4040G32GA2-TZ5K	F5-5400J4040C32GX1-TZ5K	F5-6666J4040P32GX2-TZ5K
F5-5200J4040A32GA1-TZ5K	F5-6600J3636F32GA2-TZ5K	F5-5600J3636C32GX1-TZ5K	F5-6800J4040G32GX2-TZ5K
F5-5400J3636C32GA1-TZ5K	F5-6600J4040F32GA2-TZ5K	F5-5600J4040C32GX1-TZ5K	F5-6800J4242G32GX2-TZ5K
F5-5400J4040C32GA1-TZ5K	F5-6666J4040P32GA2-TZ5K	F5-6000J3636F32GX1-TZ5K	F5-4800J3636A16GA4-TZ5K
F5-5600J3636C32GA1-TZ5K	F5-6800J4040G32GA2-TZ5K	F5-6000J4040F32GX1-TZ5K	F5-4800J4040A16GA4-TZ5K
F5-5600J4040C32GA1-TZ5K	F5-6800J4242G32GA2-TZ5K	F5-6200J3636F32GX1-TZ5K	F5-5200J3636C16GA4-TZ5K
F5-6000J3636F32GA1-TZ5K	F5-4800J3636A32GX4-TZ5K	F5-6200J4040F32GX1-TZ5K	F5-5200J4040A16GA4-TZ5K
F5-6000J4040F32GA1-TZ5K	F5-4800J4040A32GX4-TZ5K	F5-6400J3636G32GX1-TZ5K	F5-5400J3636C16GA4-TZ5K
F5-6200J3636F32GA1-TZ5K	F5-5200J3636C32GX4-TZ5K	F5-6400J4040G32GX1-TZ5K	F5-5400J4040C16GA4-TZ5K

Trident Z5



F5-5600J3636C16GA4-TZ5K	F5-6800J4040G16GA1-TZ5K	F5-6000J3636F16GX4-TZ5K	F5-4800J3636A16GX2-TZ5K
F5-5600J4040C16GA4-TZ5K	F5-6800J4242G16GA1-TZ5K	F5-6000J4040F16GX4-TZ5K	F5-4800J4040A16GX2-TZ5K
F5-6000J3636F16GA4-TZ5K	F5-4800J3636A16GA2-TZ5K	F5-6200J3636F16GX4-TZ5K	F5-5200J3636C16GX2-TZ5K
F5-6000J4040F16GA4-TZ5K	F5-4800J4040A16GA2-TZ5K	F5-6200J4040F16GX4-TZ5K	F5-5200J4040A16GX2-TZ5K
F5-6200J3636F16GA4-TZ5K	F5-5200J3636C16GA2-TZ5K	F5-6400J3636G16GX4-TZ5K	F5-5400J3636C16GX2-TZ5K
F5-6200J4040F16GA4-TZ5K	F5-5200J4040A16GA2-TZ5K	F5-6400J4040G16GX4-TZ5K	F5-5400J4040C16GX2-TZ5K
F5-6400J3636G16GA4-TZ5K	F5-5400J3636C16GA2-TZ5K	F5-6600J3636F16GX4-TZ5K	F5-5600J3636C16GX2-TZ5K
F5-6400J4040G16GA4-TZ5K	F5-5400J4040C16GA2-TZ5K	F5-6600J4040F16GX4-TZ5K	F5-5600J4040C16GX2-TZ5K
F5-6600J3636F16GA4-TZ5K	F5-5600J3636C16GA2-TZ5K	F5-6666J4040P16GX4-TZ5K	F5-6000J3636F16GX2-TZ5K
F5-6600J4040F16GA4-TZ5K	F5-5600J4040C16GA2-TZ5K	F5-6800J4040G16GX4-TZ5K	F5-6000J4040F16GX2-TZ5K
F5-6666J4040P16GA4-TZ5K	F5-6000J3636F16GA2-TZ5K	F5-6800J4242G16GX4-TZ5K	F5-6200J3636F16GX2-TZ5K
F5-6800J4040G16GA4-TZ5K	F5-6000J4040F16GA2-TZ5K	F5-4800J3636A16GX1-TZ5K	F5-6200J4040F16GX2-TZ5K
F5-6800J4242G16GA4-TZ5K	F5-6200J3636F16GA2-TZ5K	F5-4800J4040A16GX1-TZ5K	F5-6400J3636G16GX2-TZ5K
F5-4800J3636A16GA1-TZ5K	F5-6200J4040F16GA2-TZ5K	F5-5200J3636C16GX1-TZ5K	F5-6400J4040G16GX2-TZ5K
F5-4800J4040A16GA1-TZ5K	F5-6400J3636G16GA2-TZ5K	F5-5200J4040A16GX1-TZ5K	F5-6600J3636F16GX2-TZ5K
F5-5200J3636C16GA1-TZ5K	F5-6400J4040G16GA2-TZ5K	F5-5400J3636C16GX1-TZ5K	F5-6600J4040F16GX2-TZ5K
F5-5200J4040A16GA1-TZ5K	F5-6600J3636F16GA2-TZ5K	F5-5400J4040C16GX1-TZ5K	F5-6666J4040P16GX2-TZ5K
F5-5400J3636C16GA1-TZ5K	F5-6600J4040F16GA2-TZ5K	F5-5600J3636C16GX1-TZ5K	F5-6800J4040G16GX2-TZ5K
F5-5400J4040C16GA1-TZ5K	F5-6666J4040P16GA2-TZ5K	F5-5600J4040C16GX1-TZ5K	F5-6800J4242G16GX2-TZ5K
F5-5600J3636C16GA1-TZ5K	F5-6800J4040G16GA2-TZ5K	F5-6000J3636F16GX1-TZ5K	
F5-5600J4040C16GA1-TZ5K	F5-6800J4242G16GA2-TZ5K	F5-6000J4040F16GX1-TZ5K	
F5-6000J3636F16GA1-TZ5K	F5-4800J3636A16GX4-TZ5K	F5-6200J3636F16GX1-TZ5K	
F5-6000J4040F16GA1-TZ5K	F5-4800J4040A16GX4-TZ5K	F5-6200J4040F16GX1-TZ5K	
F5-6200J3636F16GA1-TZ5K	F5-5200J3636C16GX4-TZ5K	F5-6400J3636G16GX1-TZ5K	
F5-6200J4040F16GA1-TZ5K	F5-5200J4040D16GX4-TZ5K	F5-6400J4040G16GX1-TZ5K	
F5-6400J3636G16GA1-TZ5K	F5-5200J4040A16GX4-TZ5K	F5-6600J3636F16GX1-TZ5K	
F5-6400J4040G16GA1-TZ5K	F5-5400J3636C16GX4-TZ5K	F5-6600J4040F16GX1-TZ5K	
F5-6600J3636F16GA1-TZ5K	F5-5400J4040C16GX4-TZ5K	F5-6666J4040P16GX1-TZ5K	
F5-6600J4040F16GA1-TZ5K	F5-5600J3636C16GX4-TZ5K	F5-6800J4040G16GX1-TZ5K	
F5-6666J4040P16GA1-TZ5K	F5-5600J4040C16GX4-TZ5K	F5-6800J4242G16GX1-TZ5K	

2. Test Summary

Emission			
Standard	Test Type	Result	Remarks
EN 55032: 2015+A1: 2020	Conducted Emission	PASS	Meet Class B Limit
	Asymmetric mode Conducted emissions	N/A	N/A
	Radiated Emission	PASS	Meet Class B Limit
EN IEC 61000-3-2: 2019	Harmonic current Emissions	N/A	N/A
EN 61000-3-3: 2013+A1: 2019	Voltage fluctuation & Flicker	N/A	N/A

Immunity (EN 55035: 2017+A11: 2020)				
Standard	Test Type	Performance Criteria	Result	
IEC 61000-4-2: 2008	ESD	Criterion B	PASS	Meets the requirements of Performance Criterion A
EN IEC61000-4-3: 2020	RS	Criterion A	PASS	Meets the requirements of Performance Criterion A
IEC 61000-4-4: 2012	EFT	Criterion B	N/A	N/A
IEC 61000-4-5: 2014/ AMD1: 2017	Surge	Criterion B	N/A	N/A
IEC 61000-4-6: 2013	CS	Criterion A	N/A	N/A
IEC 61000-4-8: 2009	Magnetic Field	Criterion A	PASS	Meets the requirements of Performance Criterion A
EN IEC 61000-4-11: 2020	Dip	1. >95% reduction- Criterion B 2. 30% reduction- Criterion C	N/A	N/A
	Interruption	3. >95% reduction- Criterion C	N/A	N/A

Note: Please note that the test results with statement of conformity, the decision rules which are based on: Safety Testing: the specification, standard or IEC Guide 115.

Other Testing: the specification, standard and not taking into account the measurement uncertainty.

3. Test Specifications

3.1 Standards

EN 55032: 2015+A1: 2020 Electromagnetic compatibility of multimedia equipment - Emission requirements

EN IEC 61000-3-2: 2019 Electromagnetic compatibility (EMC) - Part 3-2: Limits - Limits for harmonic current emissions (equipment input current ≤ 16 A per phase)

EN 61000-3-3: 2013+A1: 2019 Electromagnetic compatibility (EMC) - Part 3-3: Limits - Limitation of voltage changes, voltage fluctuations and flicker in public low-voltage supply systems, for equipment with rated current ≤ 16 A per phase and not subject to conditional connection

EN 55035: 2017+A11: 2020 Electromagnetic compatibility of multimedia equipment. Immunity requirements

3.2 Classification of MME

The MME equipment defines Class A equipment and Class B equipment associated with two types of end-use environment.

The Class B requirements for equipment are intended to offer adequate protection to broadcast services within the residential environment.

Equipment intended primarily for use in a residential environment shall meet the Class B limits. All other equipment shall comply with the Class A limits.

Broadcast receiver equipment is class B equipment.

3.3 Performance criteria

The performance criteria listed below are based on those regulated in the standard.

Criteria A:

The equipment shall continue to operate as intended without operator intervention. No degradation of performance, loss of function or change of operating state is allowed below a performance level specified by the manufacturer when the equipment is used as intended.

The performance level may be replaced by a permissible loss of performance. If the minimum performance level or the permissible performance loss is not specified by the manufacturer, then either of these may be derived from the product description and documentation, and by what the user may reasonably expect from the equipment if used as intended.

Criteria B:

During the application of the disturbance, degradation of performance is allowed. However, no unintended change of actual operating state or stored data is allowed to persist after the test.

After the test, the equipment shall continue to operate as intended without operator intervention; no degradation of performance or loss of function is allowed, below a performance level specified by the manufacturer, when the equipment is used as intended. The performance level may be replaced by a permissible loss of performance.

If the minimum performance level (or the permissible performance loss), or recovery time, is not specified by the manufacturer, then either of these may be derived from the product description and documentation, and by what the user may reasonably expect from the equipment if used as intended.

Criteria C:

Loss of function is allowed, provided the function is self-recoverable, or can be restored by the operation of the controls by the user in accordance with the manufacturer's instructions. A reboot or re-start operation is allowed.

Information stored in non-volatile memory, or protected by a battery backup, shall not be lost.

TEST REPORT**3.4 Mode of operation during the test**

1. Install the EUT to the PC.
2. Operator executes "Burn In" software on the PC.

3.5 Peripherals equipment

Peripherals	Brand	Model No.	Serial No.	Description of Data Cable
Monitor	PHILIPS	223V5L	N/A	N/A
Modem	LEMEL	MD-56KVR LUS-V9	N/A	N/A
PDA	HP	IPAQ 112	N/A	N/A
Mouse	HP	MOHQQUO	N/A	N/A
Keyboard	DELL	SK-8115	N/A	N/A
PC	msi	MPG Z690 CARBOM WIFI	N/A	N/A

TEST REPORT

4. Conducted Emission Test

4.1 Test Procedure

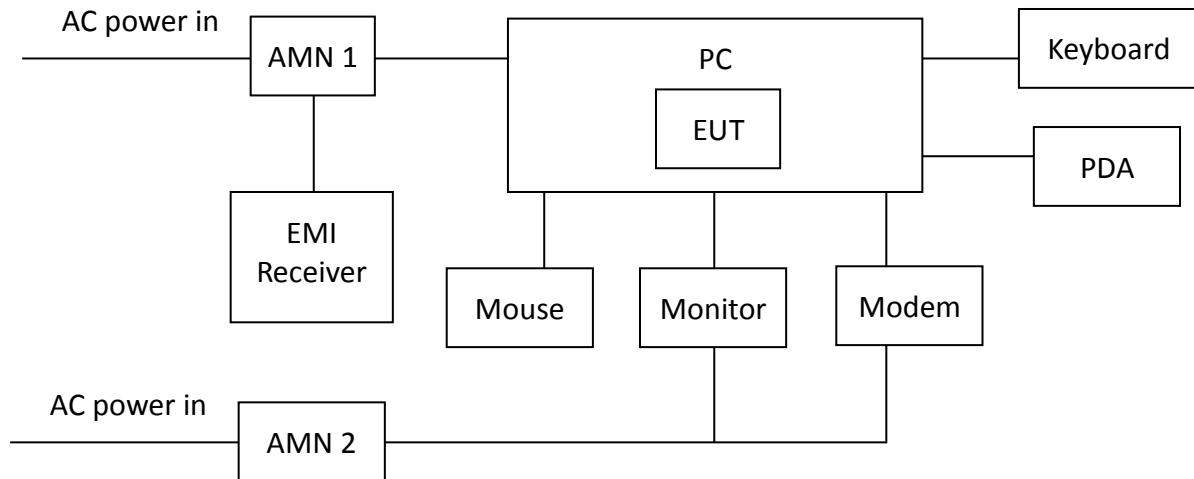

The EUT along with its peripherals were placed on a 1.0 meter(W)×1.5meter(L) and 0.8 meter in height wooden table and the EUT was adjusted to maintain a 0.4meter space from a vertical reference plane. The EUT was connected to power mains through a Artificial Mains Network (AMN), which provided 50 ohm coupling impedance for measuring instrument and the chassis ground was bounded to the horizontal ground plane of shielded room.

The excess power cable between the EUT and the AMN was bundled. All connecting cables of EUT and peripherals were moved to find the maximum emission

4.2 Test Equipment

Test Equipment	Brand	Model No.	Serial No.	Calibration Date	Next Calibration Date
EMI Test Receiver	R&S	ESCI	100018	2021/11/16	2022/11/15
AMN	R&S	ENV216	101160	2021/07/14	2022/07/13
AMN	R&S	ESH3-Z5	835239/023	2021/09/22	2022/09/21
CON-2 Cable	SUHNER	EMCCFD300-BM -NM-6000	170502	2021/04/29	2022/04/28
Test software	Audix	e3	V4.20040112L	NCR	NCR

Note: No Calibration Required (NCR).

TEST REPORT**4.3 Conducted Emission Limit**

Frequency (MHz)	Maximum RF Line Voltage	
	Class B Equipment (dB μ V)	
	Q.P.	Avg.
0.15 to 0.50	66 to 56	56 to 46
0.50 to 5.00	56	46
5.00 to 30.0	60	50

TEST REPORT

4.4 Conducted Emission Data

Model No.:	F5-6800U4242G16GX2-RS5W
Remark:	N/A

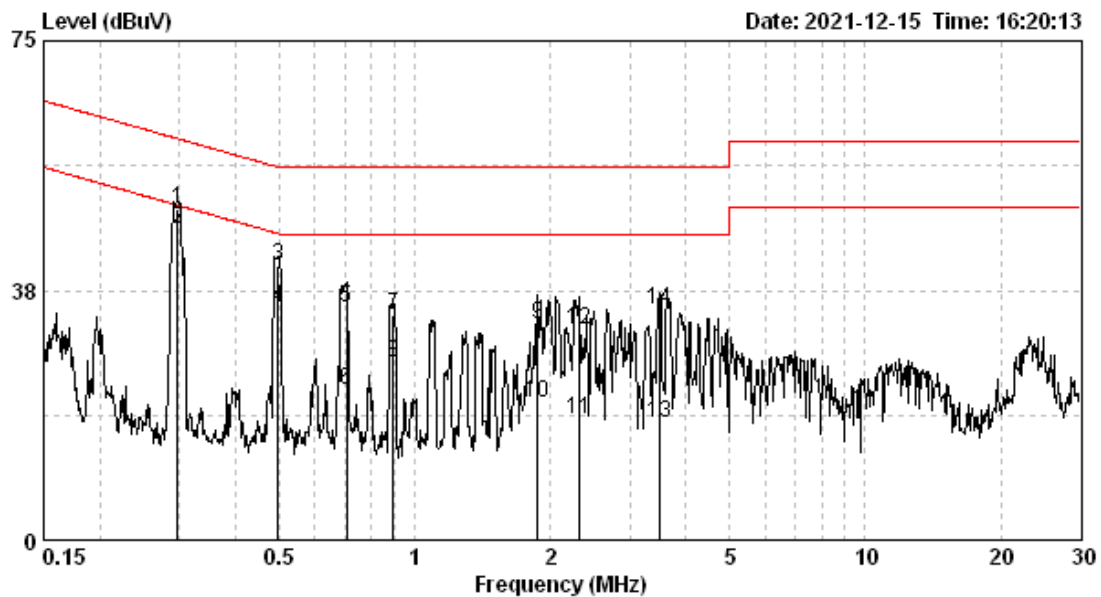

Test voltage : AC 230V 50Hz
 Temp. / R.H. : 25°C / 54%RH
 Atmospheric pressure : 1003 hPa

Phase	Frequency (MHz)	Corr. Factor (dB)	Reading QP (dBuV)	Level QP (dBuV)	Limit QP (dBuV)	Reading AV (dBuV)	Level AV (dBuV)	Limit AV (dBuV)	Margin (dB)	
									QP	AV
LINE	0.297	9.72	40.11	49.83	60.32	37.12	46.84	50.32	-10.49	-3.49
LINE	0.497	9.83	31.34	41.17	56.05	25.08	34.91	46.05	-14.89	-11.14
LINE	0.705	9.82	24.95	34.76	56.00	12.59	22.40	46.00	-21.24	-23.60
LINE	0.894	9.81	24.02	33.82	56.00	16.94	26.75	46.00	-22.18	-19.25
LINE	1.878	9.85	22.44	32.29	56.00	10.87	20.72	46.00	-23.71	-25.28
LINE	2.309	9.84	21.67	31.52	56.00	8.18	18.02	46.00	-24.48	-27.98
LINE	3.491	9.83	24.88	34.71	56.00	7.72	17.55	46.00	-21.29	-28.45

Remark:

1. Corr. Factor (dB) = AMN Factor (dB) + Cable Loss (dB)
2. Level (dBuV) = Corr. Factor (dB) + Reading (dBuV)
3. Margin (dB) = Level (dBuV) – Limit (dBuV)

TEST REPORT

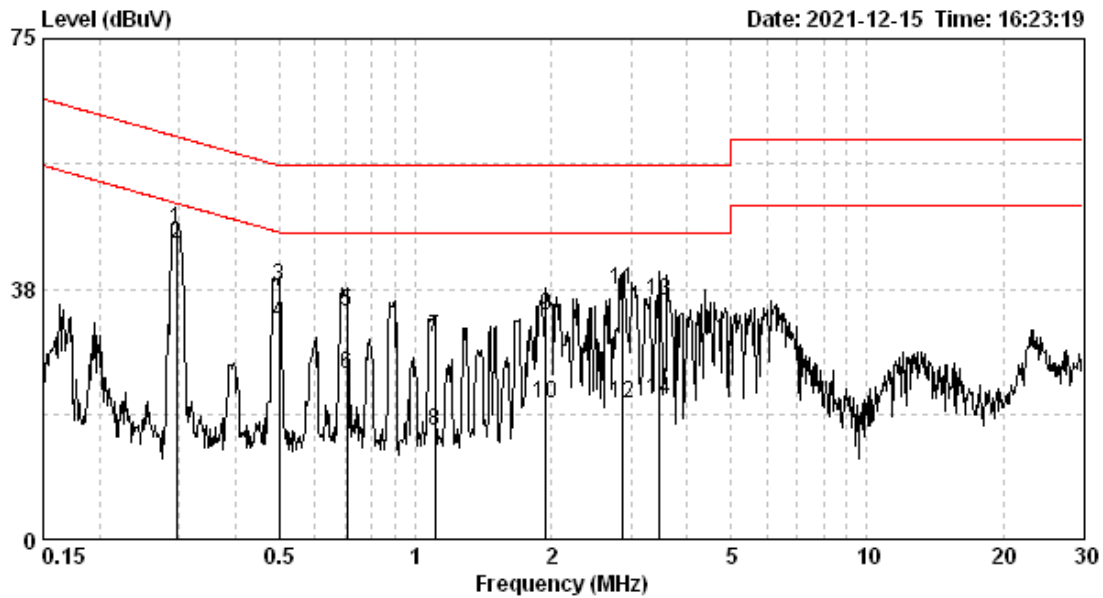

Test voltage :AC 230V 50Hz
 Temp. / R.H. :25°C / 54%RH
 Atmospheric pressure :1003 hPa

Phase	Frequency (MHz)	Corr. Factor (dB)	Reading QP (dBuV)	Level QP (dBuV)	Limit QP (dBuV)	Reading AV (dBuV)	Level AV (dBuV)	Limit AV (dBuV)	Margin (dB)	
									QP	AV
NEUTRAL	0.296	9.72	36.61	46.33	60.37	34.64	44.36	50.37	-14.03	-6.00
NEUTRAL	0.499	9.83	28.00	37.83	56.01	22.61	32.44	46.01	-18.18	-13.57
NEUTRAL	0.705	9.82	24.27	34.09	56.00	14.91	24.72	46.00	-21.91	-21.28
NEUTRAL	1.106	9.81	20.48	30.29	56.00	6.45	16.26	46.00	-25.71	-29.74
NEUTRAL	1.949	9.85	23.58	33.43	56.00	10.51	20.35	46.00	-22.57	-25.65
NEUTRAL	2.884	9.84	27.59	37.43	56.00	10.55	20.39	46.00	-18.57	-25.61
NEUTRAL	3.472	9.83	25.90	35.73	56.00	10.94	20.77	46.00	-20.27	-25.23

Remark:

1. Corr. Factor (dB) = AMN Factor (dB) + Cable Loss (dB)
2. Level (dBuV) = Corr. Factor (dB) + Reading (dBuV)
3. Margin (dB) = Level (dBuV) – Limit (dBuV)

TEST REPORT

Model No.:	F5-6800U4242G16GX2-TZ5K
Remark:	N/A

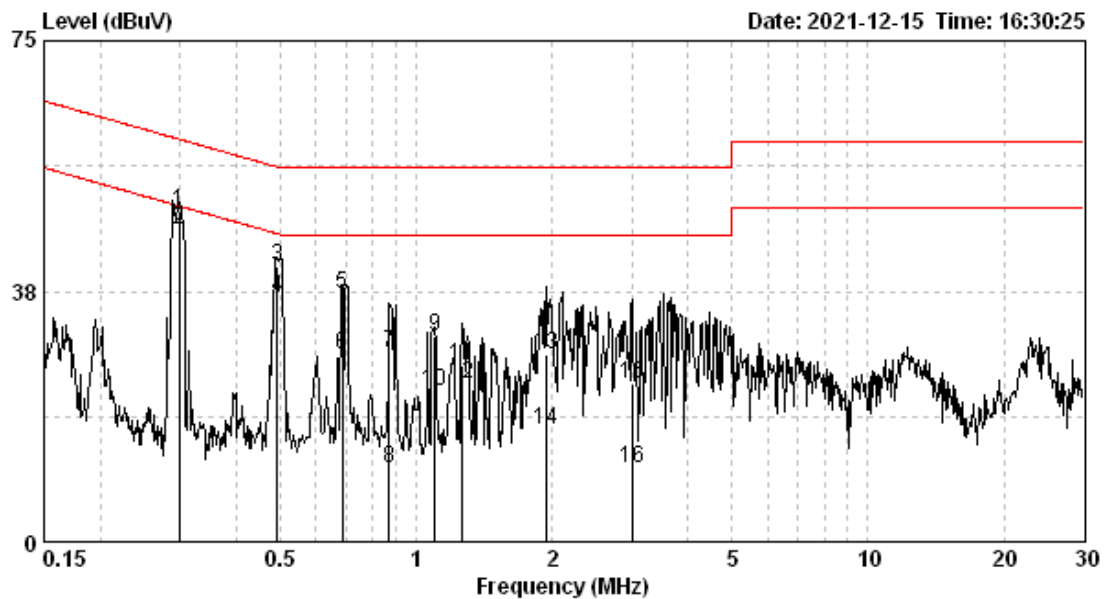

Test voltage :AC 230V 50Hz
 Temp. / R.H. :25°C / 54%RH
 Atmospheric pressure :1003 hPa

Phase	Frequency (MHz)	Corr. Factor (dB)	Reading QP (dBuV)	Level QP (dBuV)	Limit QP (dBuV)	Reading AV (dBuV)	Level AV (dBuV)	Limit AV (dBuV)	Margin (dB) QP	AV
LINE	0.299	9.72	39.85	49.57	60.28	37.08	46.80	50.28	-10.71	-3.48
LINE	0.491	9.83	31.42	41.25	56.14	26.79	36.62	46.14	-14.89	-9.52
LINE	0.686	9.82	27.24	37.06	56.00	18.18	28.00	46.00	-18.94	-18.00
LINE	0.871	9.81	18.50	28.31	56.00	1.19	11.00	46.00	-27.69	-35.00
LINE	1.100	9.81	20.93	30.73	56.00	12.85	22.66	46.00	-25.27	-23.34
LINE	1.262	9.82	16.57	26.38	56.00	13.85	23.67	46.00	-29.62	-22.33
LINE	1.939	9.85	18.23	28.08	56.00	6.90	16.75	46.00	-27.92	-29.25
LINE	3.009	9.83	13.74	23.57	56.00	1.16	11.00	46.00	-32.43	-35.00

Remark:

1. Corr. Factor (dB) = AMN Factor (dB) + Cable Loss (dB)
2. Level (dBuV) = Corr. Factor (dB) + Reading (dBuV)
3. Margin (dB) = Level (dBuV) – Limit (dBuV)

TEST REPORT

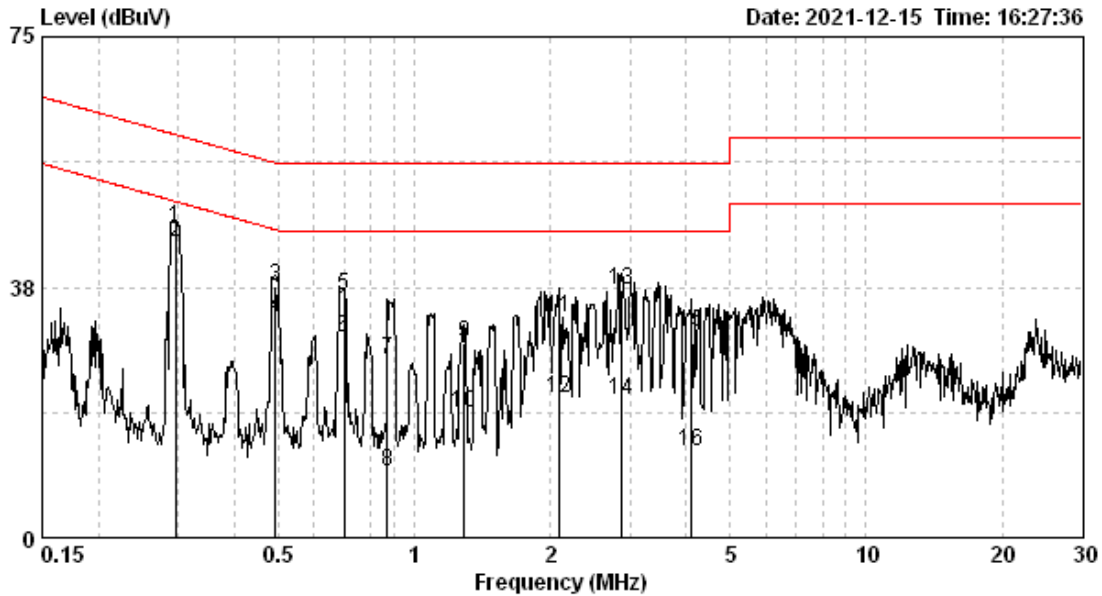

Test voltage :AC 230V 50Hz
 Temp. / R.H. :25°C / 54%RH
 Atmospheric pressure :1003 hPa

Phase	Frequency (MHz)	Corr. Factor (dB)	Reading QP (dBuV)	Level QP (dBuV)	Limit QP (dBuV)	Reading AV (dBuV)	Level AV (dBuV)	Limit AV (dBuV)	Margin (dB)	
									QP	AV
NEUTRAL	0.296	9.72	36.59	46.31	60.37	34.63	44.35	50.37	-14.05	-6.02
NEUTRAL	0.491	9.83	27.93	37.76	56.14	23.03	32.86	46.14	-18.39	-13.29
NEUTRAL	0.701	9.82	26.35	36.17	56.00	20.04	29.86	46.00	-19.83	-16.14
NEUTRAL	0.871	9.81	16.91	26.72	56.00	0.07	9.87	46.00	-29.28	-36.13
NEUTRAL	1.289	9.82	19.19	29.01	56.00	8.95	18.77	46.00	-26.99	-27.23
NEUTRAL	2.088	9.86	23.19	33.05	56.00	10.97	20.83	46.00	-22.95	-25.17
NEUTRAL	2.869	9.84	27.29	37.13	56.00	10.84	20.68	46.00	-18.87	-25.32
NEUTRAL	4.114	9.82	20.97	30.79	56.00	3.10	12.92	46.00	-25.21	-33.08

Remark:

1. Corr. Factor (dB) = AMN Factor (dB) + Cable Loss (dB)
2. Level (dBuV) = Corr. Factor (dB) + Reading (dBuV)
3. Margin (dB) = Level (dBuV) – Limit (dBuV)

5. Radiated Emission Test

5.1.1 Test Procedure from 30 MHz to 1000 MHz

The figure below shows the test setup, which is utilized to make these measurements.

Side View

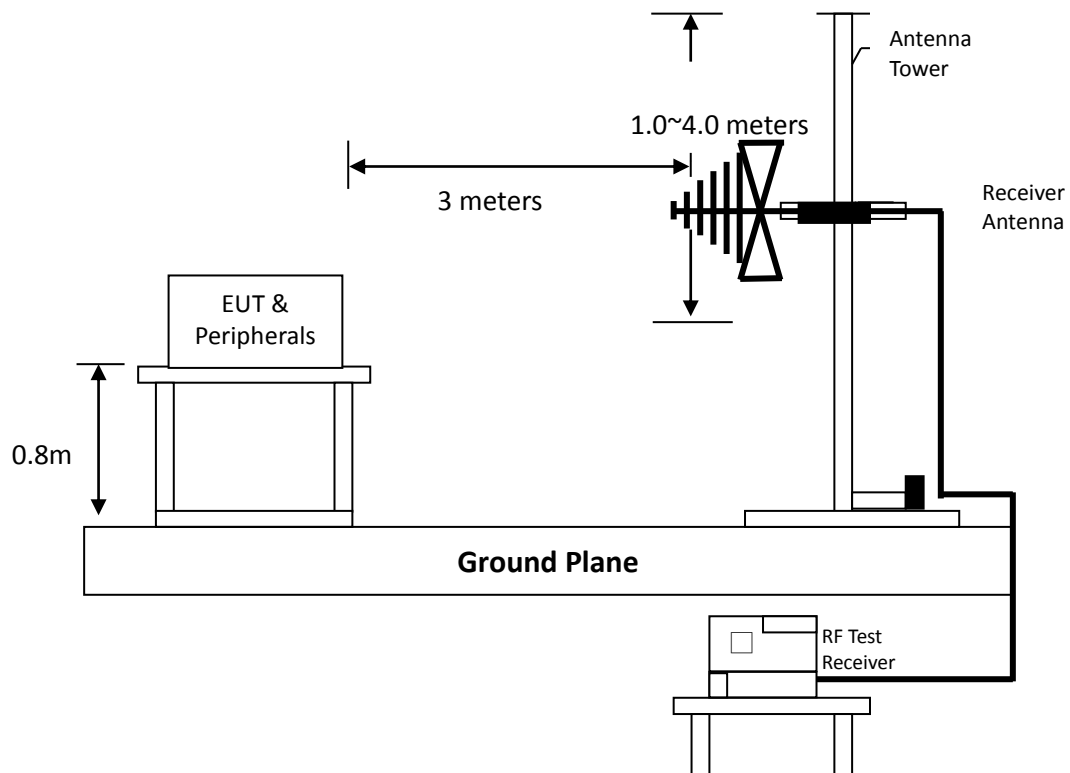

Top View

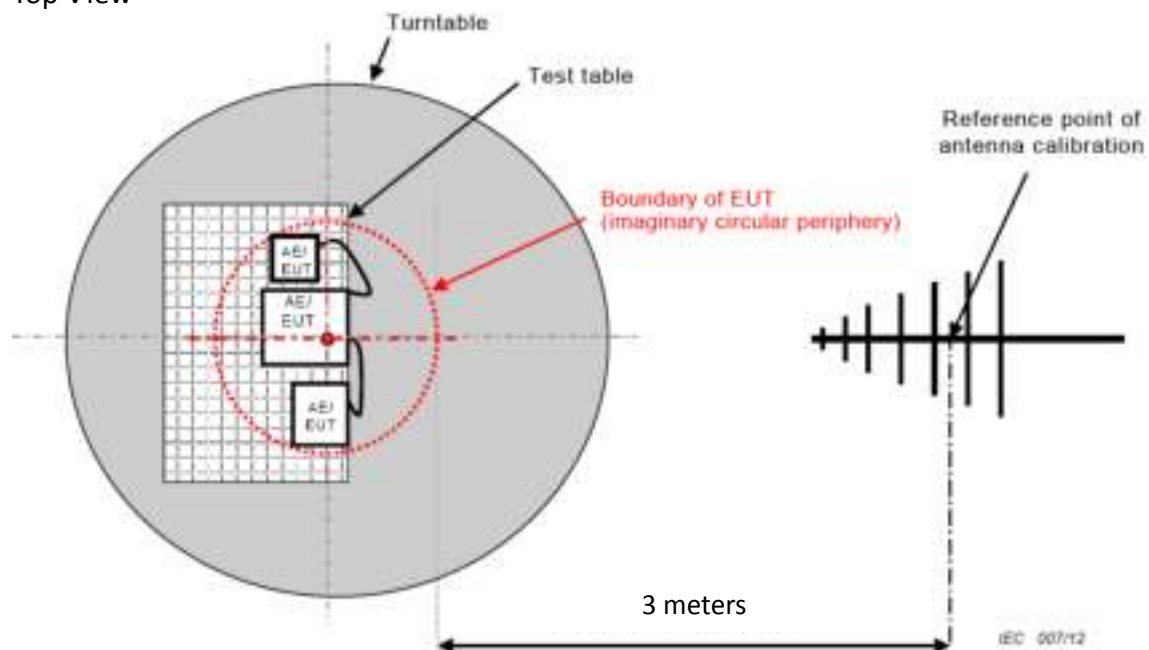

TEST REPORT

Radiated testing was performed at a 3 meters semi-anechoic chamber. The equipment under test were placed on a turntable top 0.8 meter above ground. The table was 360 degrees to determine the position of the highest radiation. EUT is set 3 meters from the EMI receiving antenna, which is mounted on a variable height mast. The antenna height is varied between one meter and four meters above ground to find the maximum value of the field strength. Both horizontal polarization and vertical polarization of the antenna was set to conduct the measurement.

The bandwidth was set on the EMI meter 120 kHz.

The levels are quasi peak value readings. The frequency spectrum from 30 MHz to 1000 MHz was investigated.

5.1.2 Test Equipment

Test Equipment	Brand	Model No.	Serial No.	Calibration Date	Next Calibration Date
EMI Test Receiver	R&S	ESU40	100381	2021/10/15	2022/10/14
Bi-log Hybrid Antenna	ETC	MCTD2786	BL13S03017	2021/01/29	2022/01/28
966-1(A) Cable	SUHNER	SMA / SUCOFLEX 104	29510614	2021/04/09	2022/04/08
966-1(B) Cable	JUNFLON	SMA / J12J100880-00	AUG-26-08-001	2021/04/09	2022/04/08
966-1_3m Semi-Anechoic Chamber	966_1	CEM-966_1	N/A	2021/01/08	2022/01/07
Test software	Audix	e3	V4.20040112L	NCR	NCR

Note: No Calibration Required (NCR).

5.1.3 Radiated Emission Limit

Frequency (MHz)	Distance(m)	Class B Equipment (dBμV/m)
30 to 230	3	40
230 to 1000	3	47

Note:

1. The tighter limit shall apply at the edge between two frequency bands.
2. Distance refers to the distance in meters between the EUT to antenna.

TEST REPORT

5.1.4 Radiated Emission Test Data from 30 MHz to 1000 MHz

Model No.:	F5-6800U4242G16GX2-RS5W
Remark:	N/A

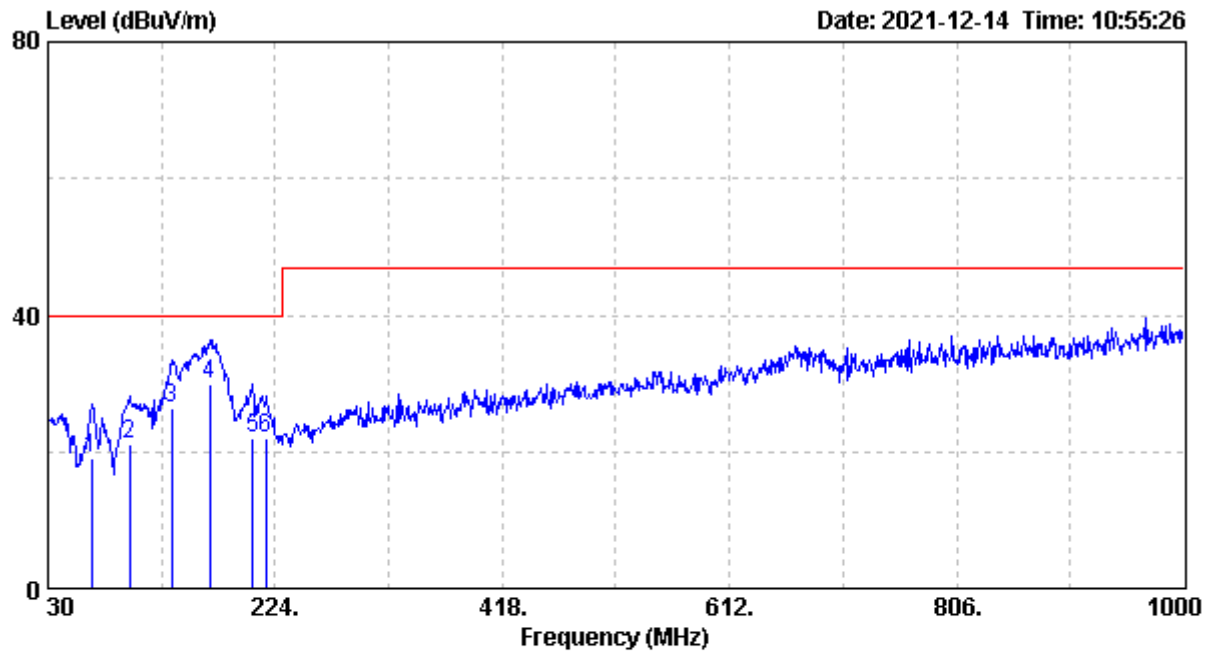

Testing Voltage : AC 230V 50Hz
 Temp. : 29°C
 Relative Humidity : 52%RH
 Atmospheric pressure: 1005 hPa

Freq	Pol/Phase	Factor	Read Level	Level	Limit Line	Over Limit	Remark
MHz		dB	dBuV	dBuV/m	dBuV/m	dB	
66.860	VERTICAL	12.95	6.10	19.05	40.00	-20.95	QP
99.840	VERTICAL	17.24	3.78	21.02	40.00	-18.98	QP
135.730	VERTICAL	19.04	7.40	26.44	40.00	-13.56	QP
167.740	VERTICAL	18.06	11.90	29.96	40.00	-10.04	QP
204.600	VERTICAL	17.74	4.19	21.93	40.00	-18.07	QP
216.240	VERTICAL	18.37	3.74	22.10	40.00	-17.90	QP

Remark:

- Factor = Antenna Factor (dB/m) + Cable Loss (dB)
- Level (dBμV/m) = Factor (dB) + Read Level (dBμV)
- Over Limit (dB) = Level (dBμV/m) – Limit Line (dBμV/m)

TEST REPORT

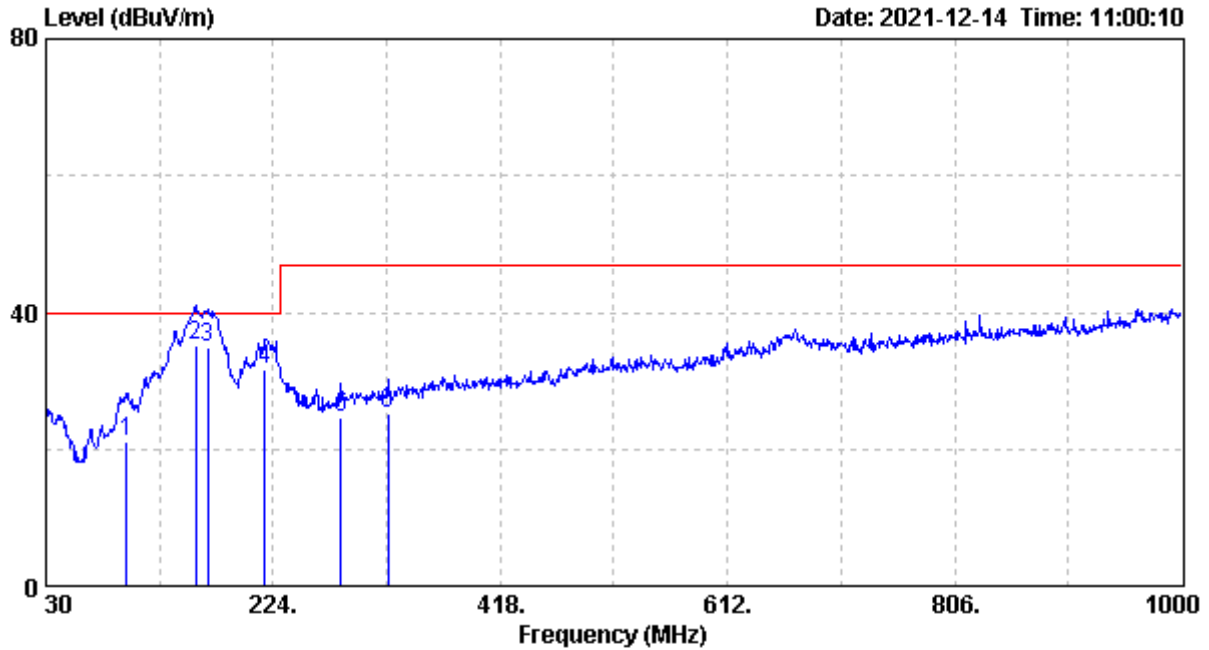

Testing Voltage :AC 230V 50Hz
 Temp. :29°C
 Relative Humidity :52%RH
 Atmospheric pressure:1005 hPa

Freq MHz	Pol/Phase	Factor dB	Read Level dBuV	Level dBuV/m	Limit Line dBuV/m	Over Limit dB	Remark
98.870	HORIZONTAL	17.16	3.89	21.05	40.00	-18.95	QP
158.040	HORIZONTAL	18.60	16.60	35.20	40.00	-4.80	QP
167.740	HORIZONTAL	18.06	16.70	34.76	40.00	-5.24	QP
217.210	HORIZONTAL	18.34	13.30	31.64	40.00	-8.36	QP
282.200	HORIZONTAL	22.06	2.65	24.71	47.00	-22.29	QP
321.970	HORIZONTAL	22.89	2.24	25.13	47.00	-21.87	QP

Remark:

- Factor = Antenna Factor (dB/m) + Cable Loss (dB)
- Level (dBμV/m) = Factor (dB) + Read Level (dBμV)
- Over Limit (dB) = Level (dBμV/m) – Limit Line (dBμV/m)

TEST REPORT

Model No.:	F5-6800U4242G16GX2-TZ5K
Remark:	N/A

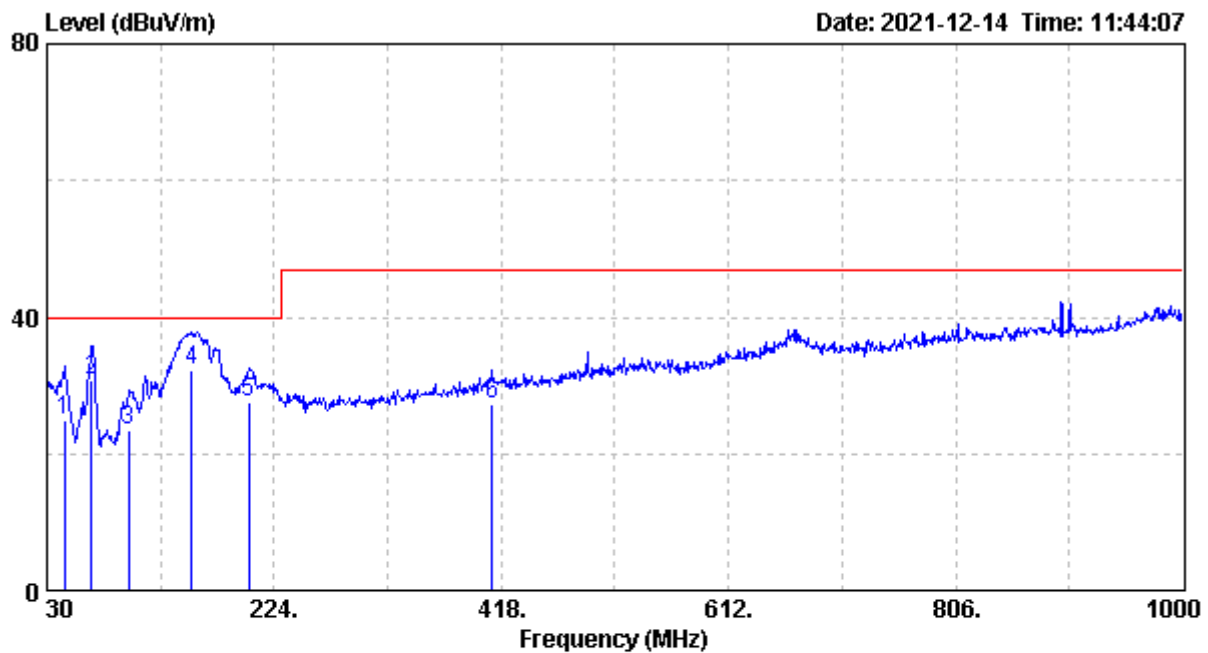

Testing Voltage :AC 230V 50Hz
 Temp. :29°C
 Relative Humidity :52%RH
 Atmospheric pressure:1005 hPa

Freq	Pol/Phase	Factor	Read Level	Level	Limit Line	Over Limit	Remark
MHz		dB	dBuV	dBuV/m	dBuV/m	dB	
44.550	VERTICAL	18.27	6.63	24.91	40.00	-15.09	QP
67.830	VERTICAL	13.02	17.82	30.85	40.00	-9.15	QP
99.840	VERTICAL	17.24	6.23	23.47	40.00	-16.53	QP
153.190	VERTICAL	18.71	13.60	32.31	40.00	-7.69	QP
202.660	VERTICAL	17.14	10.35	27.49	40.00	-12.51	QP
410.240	VERTICAL	24.86	2.25	27.11	47.00	-19.89	QP

Remark:

- Factor = Antenna Factor (dB/m) + Cable Loss (dB)
- Level (dBμV/m) = Factor (dB) + Read Level (dBμV)
- Over Limit (dB) = Level (dBμV/m) – Limit Line (dBμV/m)

TEST REPORT

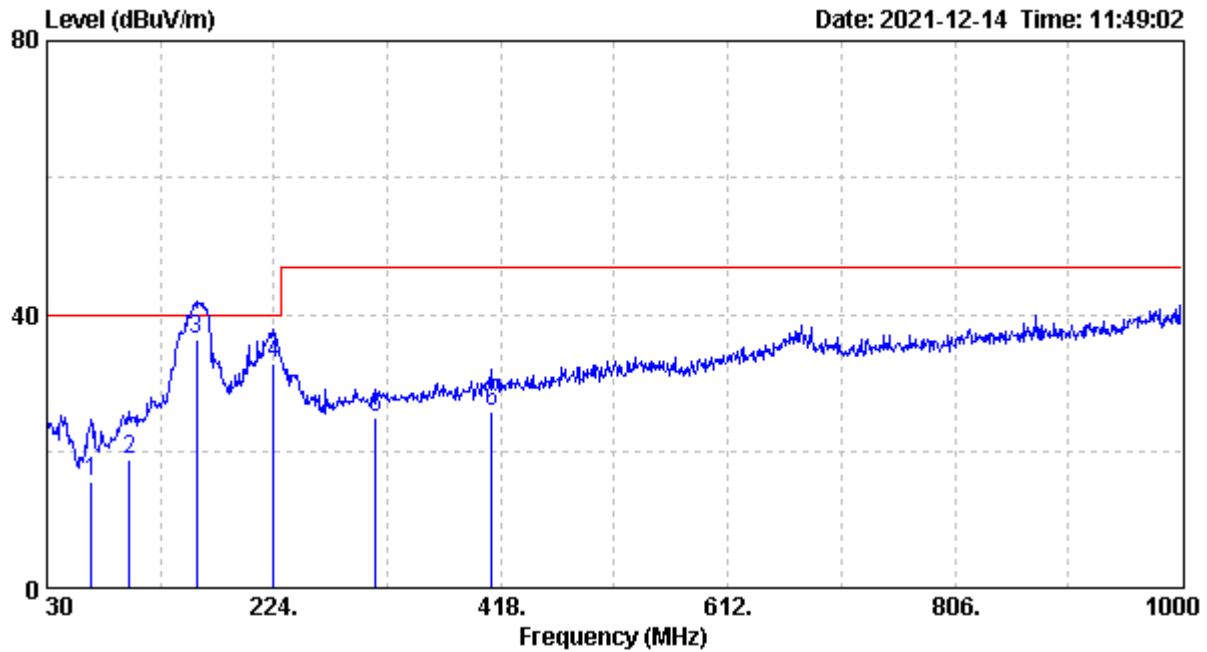

Testing Voltage : AC 230V 50Hz
 Temp. : 29°C
 Relative Humidity : 52%RH
 Atmospheric pressure: 1005 hPa

Freq	Pol/Phase	Factor	Read Level	Level	Limit Line	Over Limit	Remark
MHz		dB	dBuV	dBuV/m	dBuV/m	dB	
67.830	HORIZONTAL	13.02	2.53	15.55	40.00	-24.45	QP
100.810	HORIZONTAL	17.33	1.54	18.86	40.00	-21.14	QP
158.040	HORIZONTAL	18.60	17.60	36.20	40.00	-3.80	QP
224.000	HORIZONTAL	18.21	14.68	32.89	40.00	-7.11	QP
311.300	HORIZONTAL	22.79	2.22	25.01	47.00	-21.99	QP
410.240	HORIZONTAL	24.86	1.01	25.86	47.00	-21.14	QP

Remark:

- Factor = Antenna Factor (dB/m) + Cable Loss (dB)
- Level (dBμV/m) = Factor (dB) + Read Level (dBμV)
- Over Limit (dB) = Level (dBμV/m) – Limit Line (dBμV/m)

5.2.1 Test Procedure above 1 GHz

The figure below shows the test setup, which is utilized to make these measurements.

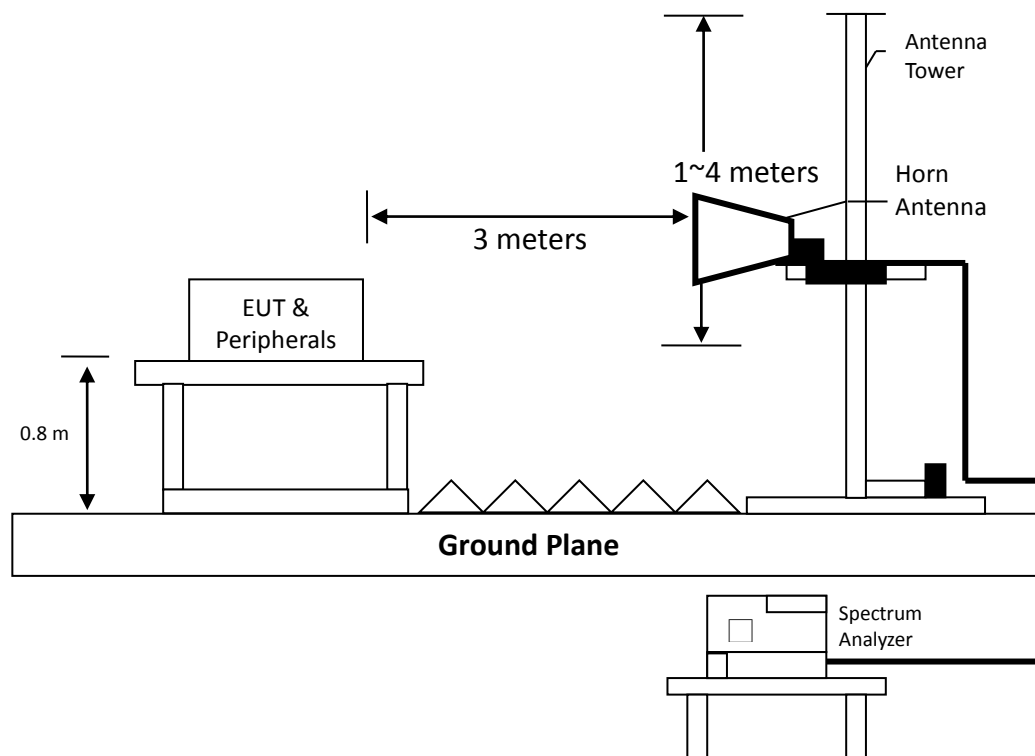

Radiated testing was performed at a 3 meters semi-anechoic chamber. The equipment under test were placed on a turntable top 0.8 meter above ground. The table was 360 degrees to determine the position of the highest radiation. EUT is set 3 meters from the EMI receiving antenna, which is mounted on a variable height mast. The antenna height is varied between one meter and four meters above ground to find the maximum value of the field strength. Both horizontal polarization and vertical polarization of the antenna was set to conduct the measurement.

The bandwidth was set on the EMI meter 1 MHz.

The levels are peak and average value readings. The frequency spectrum above 1 GHz was investigated.

TEST REPORT

5.2.2 Test Equipment

Test Equipment	Brand	Model No.	Serial No.	Calibration Date	Next Calibration Date
EMI Test Receiver	R&S	ESU40	100381	2021/10/15	2022/10/14
Horn Antenna	EMCO	3115	9906-5822	2021/05/12	2022/05/11
Microwave Amplifier	HP	8348A	3111A00567	2021/10/19	2022/10/18
966-1(A) Cable	SUHNER	SMA / SUCOFLEX 104	29510614	2021/04/09	2022/04/08
966-1(B) Cable	JUNFLON	SMA / J12J100880-00	AUG-26-08-001	2021/04/09	2022/04/08
966-1_3m Semi-Anechoic Chamber	966_1	CEM-966_1	N/A	2021/01/08	2022/01/07
Test software	Audix	e3	V4.20040112L	NCR	NCR

Note: No Calibration Required (NCR).

5.2.3 Radiated Emission Limit

Frequency (GHz)	Distance (meter)	Class B Equipment	
		Average limit (dB μ V/m)	Peak limit (dB μ V/m)
1 to 6	3	54	74

Note: The lower limit applies at the transition frequency.

TEST REPORT

5.2.4 Radiated Emission Test Data above 1 GHz

Model No.:	F5-6800U4242G16GX2-RS5W
Remark:	N/A

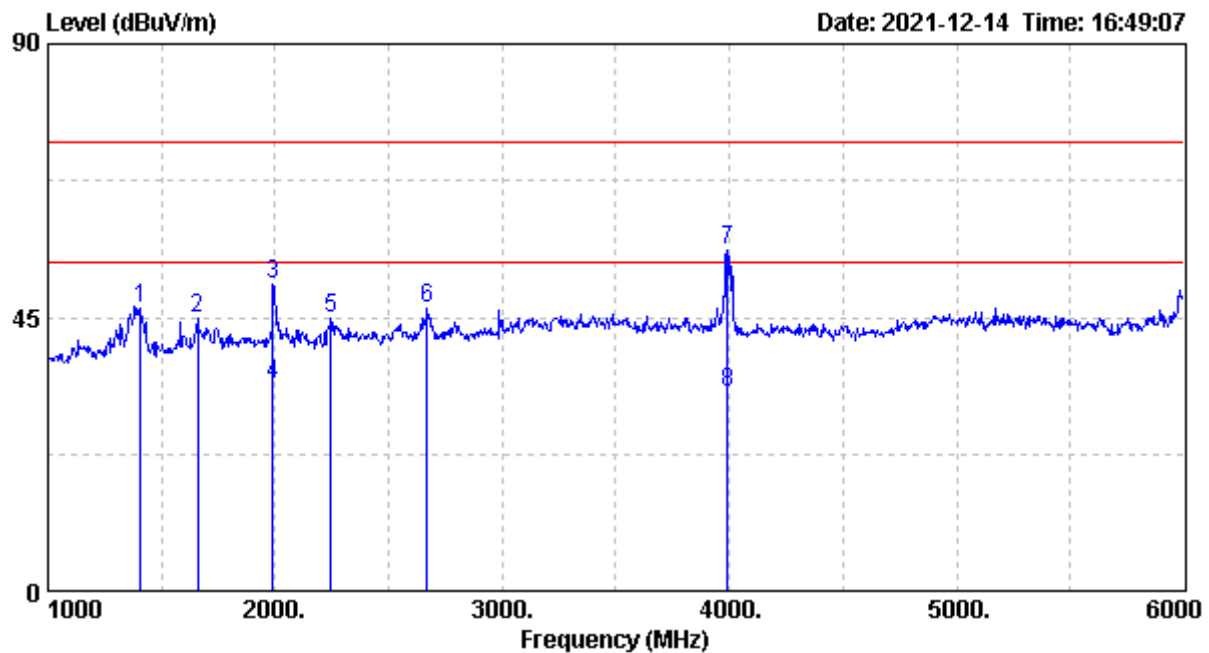

Testing Voltage :AC 230V 50Hz
 Temp. :29°C
 Relative Humidity :52%RH
 Atmospheric pressure:1005 hPa

Freq	Pol/Phase	Factor	Read Level	Level	Limit Line	Over Limit	Remark
MHz		dB	dBuV	dBuV/m	dBuV/m	dB	
1410.000	VERTICAL	-2.21	48.71	46.50	74.00	-27.50	Peak
1660.000	VERTICAL	-2.68	47.60	44.92	74.00	-29.08	Peak
1990.000	VERTICAL	-0.49	50.87	50.37	74.00	-23.63	Peak
1990.000	VERTICAL	-0.49	34.60	34.11	54.00	-19.89	Average
2245.000	VERTICAL	0.29	44.65	44.94	74.00	-29.06	Peak
2670.000	VERTICAL	2.46	43.89	46.35	74.00	-27.65	Peak
3990.000	VERTICAL	8.35	47.81	56.16	74.00	-17.84	Peak
3990.000	VERTICAL	8.35	24.20	32.55	54.00	-21.45	Average

Remark:

- Level (dBμV/m) = Factor (dB) + Read Level (dBμV)
- Factor = Antenna Factor (dB/m) + Cable Loss (dB) – Amplifier Gain (dB)
 (*The Amplifier Gain depended on measure equipment, see test equipment list.)
- Over Limit (dB) = Level (dBμV/m) – Limit Line (dBμV/m)

TEST REPORT

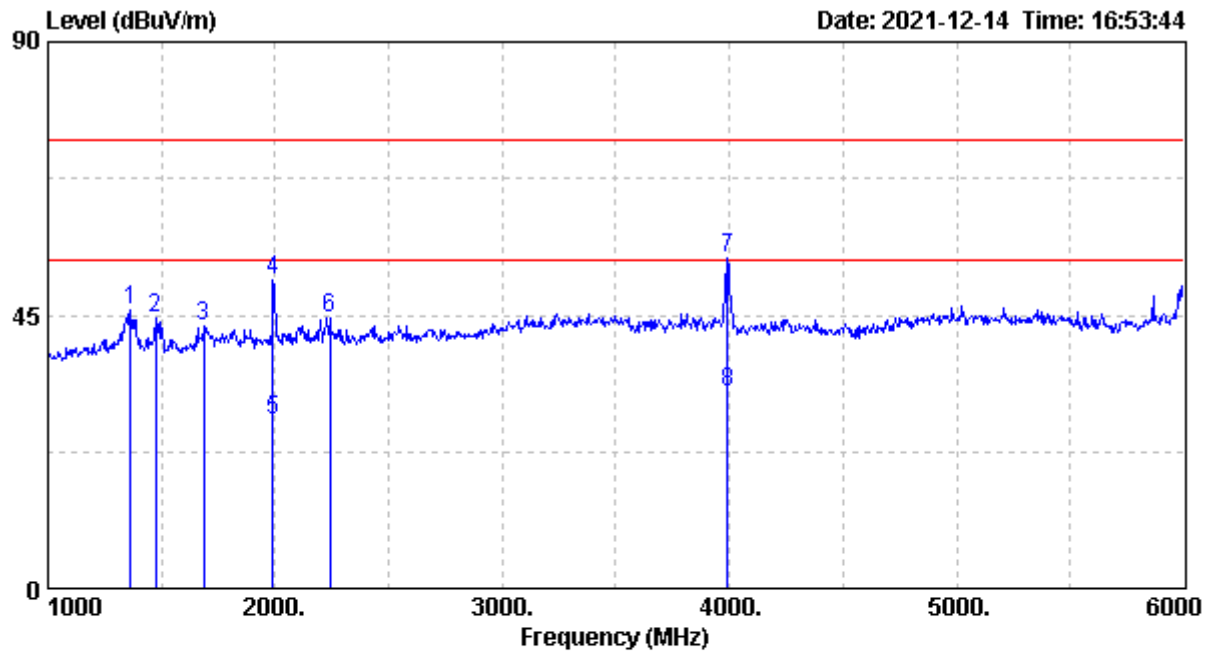

Testing Voltage :AC 230V 50Hz
 Temp. :29°C
 Relative Humidity :52%RH
 Atmospheric pressure:1005 hPa

Freq	Pol/Phase	Factor	Read Level	Level	Limit Line	Over Limit	Remark
MHz		dB	dBuV	dBuV/m	dBuV/m	dB	
1365.000	HORIZONTAL	-1.58	47.53	45.95	74.00	-28.05	Peak
1475.000	HORIZONTAL	-2.61	47.23	44.63	74.00	-29.37	Peak
1685.000	HORIZONTAL	-2.46	45.76	43.30	74.00	-30.70	Peak
1990.000	HORIZONTAL	-0.49	51.24	50.74	74.00	-23.26	Peak
1990.000	HORIZONTAL	-0.49	28.30	27.81	54.00	-26.19	Average
2240.000	HORIZONTAL	0.29	44.31	44.60	74.00	-29.40	Peak
3990.000	HORIZONTAL	8.35	46.03	54.38	74.00	-19.62	Peak
3990.000	HORIZONTAL	8.35	23.80	32.15	54.00	-21.85	Average

Remark:

- Level (dBμV/m) = Factor (dB) + Read Level (dBμV)
- Factor = Antenna Factor (dB/m) + Cable Loss (dB) – Amplifier Gain (dB)
 (*The Amplifier Gain depended on measure equipment, see test equipment list.)
- Over Limit (dB) = Level (dBμV/m) – Limit Line (dBμV/m)

TEST REPORT

Model No.:	F5-6800U4242G16GX2-TZ5K
Remark:	N/A

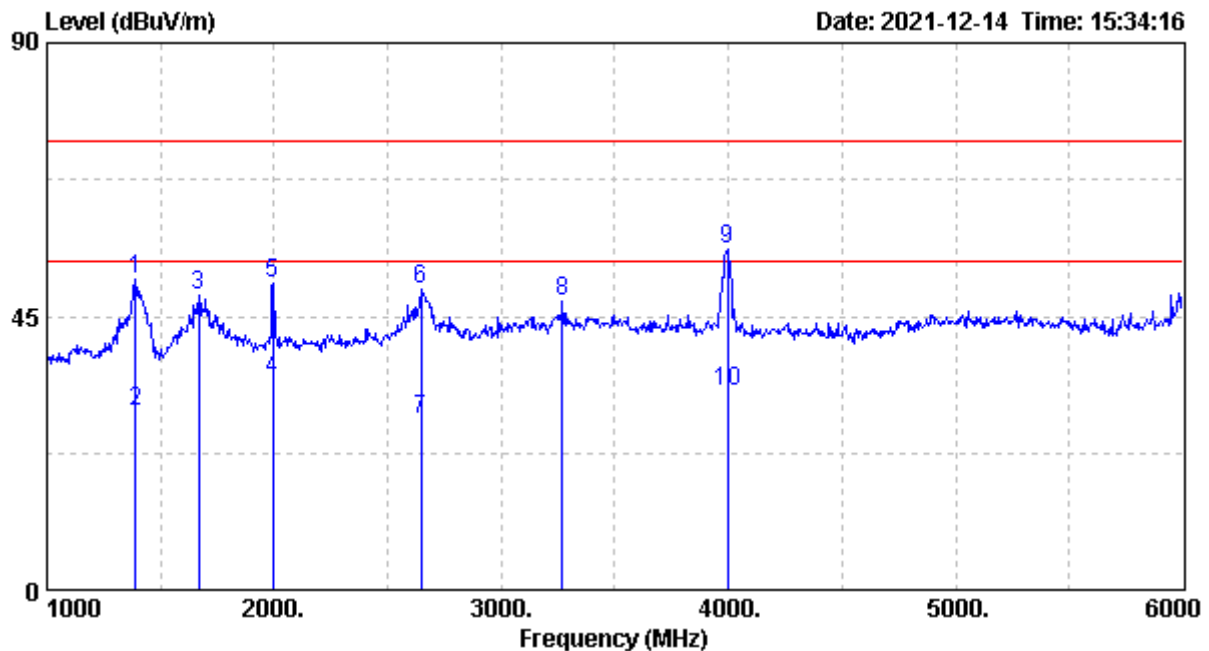

Testing Voltage :AC 230V 50Hz
 Temp. :29°C
 Relative Humidity :52%RH
 Atmospheric pressure:1005 hPa

Freq	Pol/Phase	Factor	Read Level	Level	Limit	Over	Remark
MHz		dB	dBuV	dBuV/m	dBuV/m	dB	
1390.000	VERTICAL	-2.01	53.15	51.14	74.00	-22.86	Peak
1390.000	VERTICAL	-2.01	31.40	29.39	54.00	-24.61	Average
1670.000	VERTICAL	-2.68	51.04	48.36	74.00	-25.64	Peak
1995.000	VERTICAL	-0.48	35.20	34.72	54.00	-19.28	Average
1995.000	VERTICAL	-0.48	51.02	50.54	74.00	-23.46	Peak
2645.000	VERTICAL	2.36	47.10	49.46	74.00	-24.54	Peak
2645.000	VERTICAL	2.36	25.80	28.16	54.00	-25.84	Average
3270.000	VERTICAL	6.05	41.27	47.32	74.00	-26.68	Peak
3995.000	VERTICAL	8.35	47.79	56.14	74.00	-17.86	Peak
3995.000	VERTICAL	8.35	24.40	32.75	54.00	-21.25	Average

Remark:

- Level (dBμV/m) = Factor (dB) + Read Level (dBμV)
- Factor = Antenna Factor (dB/m) + Cable Loss (dB) – Amplifier Gain (dB)
 (*The Amplifier Gain depended on measure equipment, see test equipment list.)
- Over Limit (dB) = Level (dBμV/m) – Limit Line (dBμV/m)

TEST REPORT

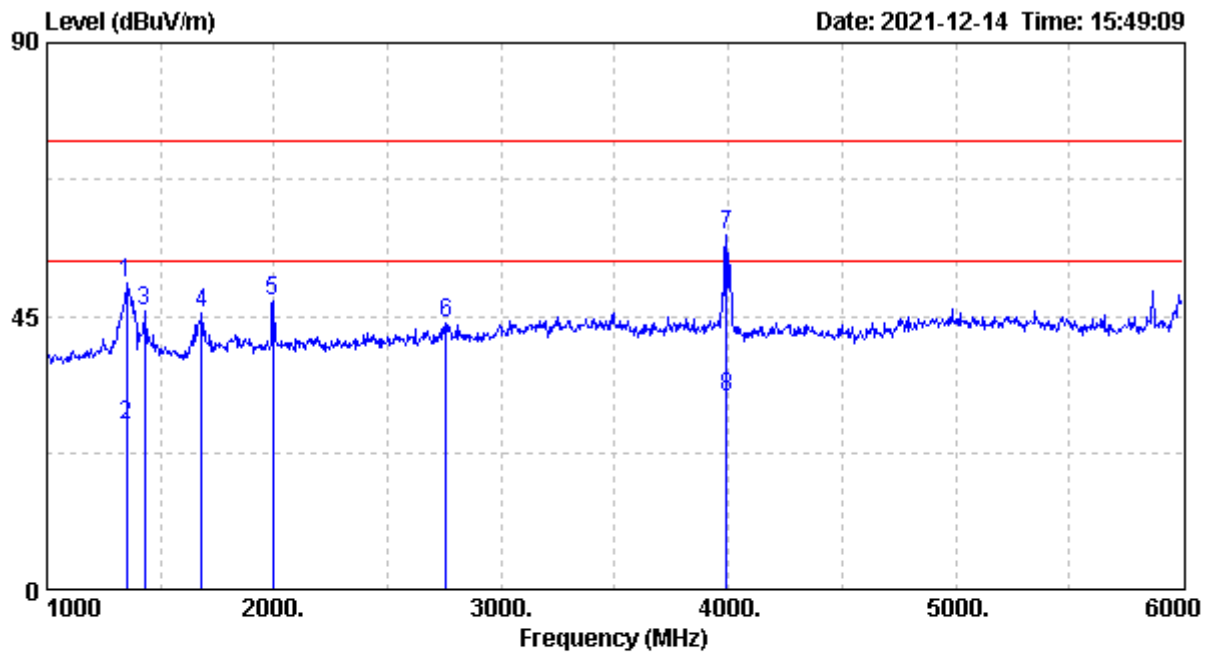

Testing Voltage :AC 230V 50Hz
 Temp. :29°C
 Relative Humidity :52%RH
 Atmospheric pressure:1005 hPa

Freq	Pol/Phase	Factor	Read Level	Level	Limit Line	Over Limit	Remark
MHz		dB	dBuV	dBuV/m	dBuV/m	dB	
1350.000	HORIZONTAL	-1.62	52.17	50.55	74.00	-23.45	Peak
1350.000	HORIZONTAL	-1.62	28.60	26.98	54.00	-27.02	Average
1430.000	HORIZONTAL	-2.33	48.09	45.77	74.00	-28.23	Peak
1680.000	HORIZONTAL	-2.46	48.10	45.64	74.00	-28.36	Peak
1995.000	HORIZONTAL	-0.48	47.87	47.39	74.00	-26.61	Peak
2755.000	HORIZONTAL	2.69	41.13	43.82	74.00	-30.18	Peak
3990.000	HORIZONTAL	8.35	49.98	58.33	74.00	-15.67	Peak
3990.000	HORIZONTAL	8.35	23.30	31.65	54.00	-22.35	Average

Remark:

1. Level (dBμV/m) = Factor (dB) + Read Level (dBμV)
2. Factor = Antenna Factor (dB/m) + Cable Loss (dB) – Amplifier Gain (dB)
 (*The Amplifier Gain depended on measure equipment, see test equipment list.)
3. Over Limit (dB) = Level (dBμV/m) – Limit Line (dBμV/m)

6. Harmonics Test

Since the EUT is not connected to AC source, therefore, the test can be waived.

7. Voltage Fluctuations-Flicker Test

Since the EUT is not connected to AC source, therefore, the test can be waived.

TEST REPORT**8. Electrostatic Discharge Immunity Test****8.1 Purpose**

The object of the test is to evaluate the ESD immunity performance of EUT.

8.2 Test Set-Up

A horizontal coupling plane (HCP) was placed on a non-metallic table 0.8 meter above a reference ground plane (RGP) and connected to it with a cable with two 470 k Ω resistors. The EUT was placed on an insulation sheet on the HCP and was operated according to the specified operating mode.

A vertical coupling plane (VCP) was connected to the RGP with a cable with two 470 k Ω resistors.

8.3 Test Specification

Test level: Air discharge ----- +/- 8 kV
 Contact discharge ----- +/- 4 kV

Single discharge at 1 second interval positive discharge and negative discharge
The selected test points are listed in this table, the numbers refer to the figures attached.

8.4 Test Equipment

Test Equipment	Brand	Model No.	Serial No.	Calibration Date	Next Calibration Date
Electrostatic Discharge System	NoiseKen	ESS-2002	ESS0291088	2021/07/27	2022/07/26

TEST REPORT

8.5 Test Result

Temperature:	22	°C	Model No.:	F5-6800U4242G16GX2-RS5W; F5-6800U4242G16GX2-TZ5K
Relative Humidity:	55	%RH	Test Date:	2021/12/17
Atmospheric Pressure:	1006	hPa	Test Voltage:	230Vac, 50Hz
Remark:	N/A			

Point of Discharge	Applied Voltage (kV)	Number of Discharge	Test Result	Performance Criterion
Air Test Point	±8	20	PASS	A
VCP (4 sides)	±4	50	PASS	A
HCP (4 sides)	±4	50	PASS	A

Description of Discharge Point

Contact Discharge <u>Q</u> Test points		Air Discharge	
<input type="checkbox"/>	Metallic Screws	<input type="checkbox"/>	Plastic Screws
<input type="checkbox"/>	Metallic Case	<input checked="" type="checkbox"/>	Plastic Case (gap)
<input type="checkbox"/>	Metallic Connect ports	<input type="checkbox"/>	Plastic Connect ports
<input type="checkbox"/>	Metallic Junctions	<input type="checkbox"/>	Plastic Junctions
<input type="checkbox"/>	Others:	<input type="checkbox"/>	LED indicator
		<input type="checkbox"/>	Panel Board
		<input type="checkbox"/>	Others:

TEST REPORT**9. Radiated, Radio-Frequency, Electromagnetic Field Immunity Test****9.1 Purpose**

This test method subjects the EUT to a power source of disturbance comprising electric and magnetic field, simulating those coming from intentional RF transmitters.

9.2 Test Set-Up

The EUT was placed on a non-metallic table 0.8 meter above the reference ground plane (RGP) and was operated according to its specified operating mode.

Ferrite tiles/absorbers were placed on the RGP between the EUT and the antenna to reduce the reflections from the RGP. The EUT and its cables were exposed for the electromagnetic field for 1.5meter vertically and 1.5m horizontally.

The distance between antenna and EUT is 3 meter.

9.3 Test Specification

Frequency range	Test field strength V/m	Modulation
80MHz ~ 1GHz	3	1 kHz 80% AM
1800MHz ±1 %		
2600MHz ±1 %		
3500MHz ±1 %		
5000MHz ±1 %		

The frequency steps : 1 % , Log sweep

Dwell time : 3 sec

Test ports : Enclosure port

TEST REPORT

9.4 Test Equipment

Test Equipment/ Test site	Brand	Model No.	Serial No.	Calibration Date	Next Calibration Date
733 Compact Full Anechoic Chamber	Comtest	9708093	N/A	2021/09/09	2022/09/08
Signal Generator	R&S	SMB100A	102385	2021/02/22	2022/02/21
Field Meter	Narda	NBM-520	D-1426	2021/01/21	2022/01/20
Field Probe	Narda	EF0691	H-0199	2021/01/25	2022/01/24
Test software	Audix	i2	V5.160923	NCR	NCR

Note: No Calibration Required (NCR).

9.5 Generation of the Electromagnetic Field

The electromagnetic field is generated from a computer controlled signal generator. The output power is amplified and then radiated from broadband log periodic antennas. For each sweep a pre-recorded empty chamber calibration file is used to establish the required field strength. When using these files the field strength inside an area of 1.5/1.0 meter x 1.5 meter is in accordance with the standard.

TEST REPORT

9.6 Test Results

Temperature:	22	°C	Model No.:	F5-6800U4242G16GX2-RS5W; F5-6800U4242G16GX2-TZ5K
Relative Humidity:	55	%RH	Test Date:	2021/12/15
Atmospheric Pressure:	1006	hPa	Test Voltage:	230Vac, 50Hz
Remark:	N/A			

Exposed Side: Front Left Rear Right

Frequency	Antenna Polarization	Test Level	Test Result	Performance Criterion
80 MHz to 1 GHz	Vertical	3V/m	PASS	A
80 MHz to 1 GHz	Horizontal	3V/m	PASS	A
1800MHz ±1 %	Vertical	3V/m	PASS	A
1800MHz ±1 %	Horizontal	3V/m	PASS	A
2600MHz ±1 %	Vertical	3V/m	PASS	A
2600MHz ±1 %	Horizontal	3V/m	PASS	A
3500MHz ±1 %	Vertical	3V/m	PASS	A
3500MHz ±1 %	Horizontal	3V/m	PASS	A
5000MHz ±1 %	Vertical	3V/m	PASS	A
5000MHz ±1 %	Horizontal	3V/m	PASS	A

10. Electrical Fast Transient/Burst Immunity Test

Since the EUT is not connected to AC source, therefore, the test can be waived.

11. Surge Immunity Test

Since the EUT is not connected to AC source, therefore, the test can be waived.

12. Immunity to Conducted Disturbances, Inducted by Radio-Frequency Fields

Since the EUT is not connected to AC source, therefore, the test can be waived.

TEST REPORT

13. Power Frequency Magnetic Field Immunity Test

13.1 Purpose

The measurement is for evaluating the performance of EUT, when subject to power frequency magnetic field disturbance.

13.2 Test Set-Up

The EUT was placed on a wooden table above a reference RGP with the coupling loop antenna arrange the EUT on the RGP.

13.3 Test Condition

Test levels for continuous field

Level	Magnetic field strength (A/m)
1	1
2	3
3	10
4	30
5	100
X ⁽¹⁾	Special
Note: 1. "x" is an open level. This level can be given in the product specification.	

Test levels for short duration: 1s to 3s

Level	Magnetic field strength (A/m)
1	n.a ⁽²⁾
2	n.a ⁽²⁾
3	n.a ⁽²⁾
4	300
5	1000
X ⁽¹⁾	Special
Note: 1. "x" is an open level. This level, as well the duration of the test, can be given in this product specification. 2. "n.a" = not applicable	

TEST REPORT

13.4 Test Equipment.

Test Equipment	Brand	Model No.	Serial No.	Calibration Date	Next Calibration Date
Induction Coil Interface	Teseq	INA 2141	1440	2021/10/27	2022/10/26
Magneticfield Coil	Teseq	INA 703	2021	2021/10/27	2022/10/26
EMF Meter	Lutron	EMF-823	l.314982	2020/08/05	2022/08/04
Test software	Teseq	Win2120	V 6.00	NCR	NCR

Note: No Calibration Required (NCR).

13.5 Test Result

Temperature:	22	°C	Model No.:	F5-6800U4242G16GX2-RS5W; F5-6800U4242G16GX2-TZ5K
Relative Humidity:	55	%RH	Test Date:	2021/12/15
Atmospheric Pressure:	1006	hPa	Test Voltage:	230Vac, 50Hz
Remark:	N/A			

Continuous Field (50 or 60 Hz)					Short Duration				
Level	H.Field (A/m)	X	Y	Z	Level	H.Field (A/m)	X	Y	Z
		Performance Criterion					Performance Criterion		
1	1	A	A	A	1	N/A	-	-	-
2	3	-	-	-	2	N/A	-	-	-
3	10	-	-	-	3	N/A	-	-	-
4	30	-	-	-	4	300	-	-	-
5	100	-	-	-	5	1000	-	-	-
X	Special	-	-	-	X	Special	-	-	-

Note: 1. "-" means not applicable
 2. Magnetic field ambient level: 0.03 uT

14. Voltage Dips, Short Interruptions and Voltage Variations Immunity Test

Since the EUT is not connected to AC source, therefore, the test can be waived.

TEST REPORT

Appendix A: Uncertainty

This uncertainty represents an expanded uncertainty expressed at approximately the 95% confidence level using a coverage factor of k=2.

Item	Uncertainty
Conducted disturbance measurements at a mains port from 9 kHz to 30 MHz using a 50 Ω/50 μH +5Ω artificial mains network (AMN)	3.08 dB
Conducted disturbance measurements at a telecommunication port from 150 kHz to 30 MHz using an asymmetrical artificial network (AAN)	3.78 dB
Vertically polarized radiated disturbances from 30MHz~1GHz in an open area test site at a distance of 10m	5.18 dB
Horizontally polarized radiated disturbances from 30MHz~1GHz in an open area test site at a distance of 10m	5.05 dB
Vertically polarized radiated disturbances from 30MHz~1GHz in a semi-anechoic chamber at a distance of 3m	5.16 dB
Horizontally polarized radiated disturbances from 30MHz~1GHz in a semi-anechoic chamber at a distance of 3m	5.02 dB
Radiated disturbances from 1GHz~18GHz in a semi-anechoic chamber at a distance of 3m	5.17 dB
HARMONIC	0.39 %
FLICKER	0.17 %
ESD	7.23 %
RS	1.54 dB
RS (Audio)	1.64 dB
EFT	4.30 %
SURGE	4.20 %
CS	1.08 dB
CS (Audio)	1.18 dB
Mag.	13.00 %
DIP	0.87 %
Ring Wave	4.20 %
Immunity to low-frequency signals	0.17%

Appendix B1: Photo of EUT (Model No.: F5-6800U4242G16GX2-RS5W)



Appendix B2: Photo of EUT (Model No.: F5-6800U4242G16GX2-TZ5K)



Appendix C1: Conducted Emission Test Set-up



Appendix C2: Radiated Emission Test Set-up (Below 1GHz)



Appendix C3: Radiated Emission Test Set-up (Above 1GHz)

