

Sharkoon

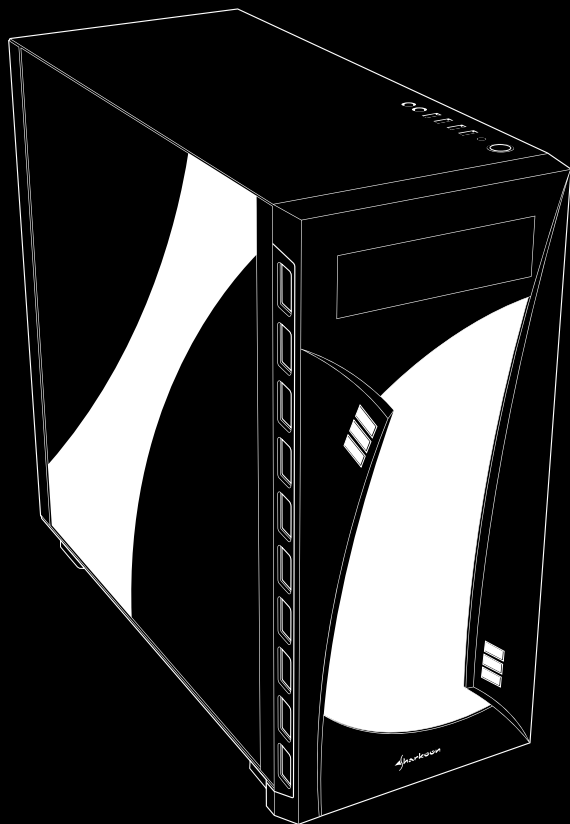

# NIGHTSHARK

Manual • Anleitung • Manuel • Manuale dell'utente • Handleiding  
Instrukcja • Használati útmutató • Manuál • 使用説明 • マニュアル

# Specifications

- Spezifikationen
- Spécifications
- Specifiche tecniche
- Especificaciones
- Especificações
- Specificaties
- Specyfikacja
- Műszaki adatok
- Specificace
- Technické údaje
- 規格
- 仕様

General:	NIGHT SHARK RGB	NIGHT SHARK Red / Blue	NIGHT SHARK Lite
■ Form Factor	ATX, E-ATX	ATX, E-ATX	ATX, E-ATX
■ Expansion Slots	7	7	7
■ Interior Painting	✓	✓	✓
■ Cable Management System	✓	✓	✓
■ Side Panel Tempered Glass 3 mm	✓	✓	✓
■ Dimensions (L x W x H)	50.3 x 21.0 x 47.5 cm	50.3 x 21.0 x 47.5 cm	50.3 x 21.0 x 47.5 cm

## I/O:

■ USB 3.0 (Top)	2	2	2
■ USB 2.0 (Top)	2	2	2
■ Audio (Top)	✓	✓	✓

## Max. Drive Bays:

■ 5.25"	1	1	1
■ 3.5"	3	3	3
■ 2.5"	5	5	5

## Fan Configuration:

■ Front Panel	2x 120 mm RGB Fans	2x 120 mm LED Fans	Optional
■ Side Panel	Optional*	Optional*	Optional*
■ Rear Panel	1x 120 mm RGB Fan	1x 120 mm LED Fan	Optional
■ Bottom Panel	Optional**	Optional**	Optional**

## Compatibility:

■ Mainboard	Mini-ITX, Micro-ATX, ATX, E-ATX, SSI CEB, SSI EEB		
■ Max. Length Graphics Cards	42 cm***	42 cm***	42 cm***
■ Max. Height CPU Cooler	16 cm	16 cm	16 cm
■ Max. Length Power Supply	29.5 cm	29.5 cm	29.5 cm

## Package Contents:

■ NIGHT SHARK, Accessory Set, Manual, Addressable RGB Control (only NIGHT SHARK RGB)
--

\* If HDD/SSD mounting cover is removed, 2x 120 mm fans or 240 mm radiator can be installed.

\*\* Internal USB 3.0 connection to mainboard may conflict with space for radiator. Check before installation.

\*\*\* 30 cm if radiator is installed on side panel.

## 5.25" Device Installation

- Einbau 5,25"-Laufwerk
- Installation du périphérique 5,25"
- Installazione unità da 5,25"
- Instalación de dispositivo 5,25"
- 5,25" Instalação de dispositivo
- Installatie 5,25" apparaat
- 5,25" montaž urządzeń
- 5,25" eszköz beszerelhetőség
- Instalace 5,25" jednotky
- 5.25" 装置安裝
- 5.25 インチデバイスの取付け

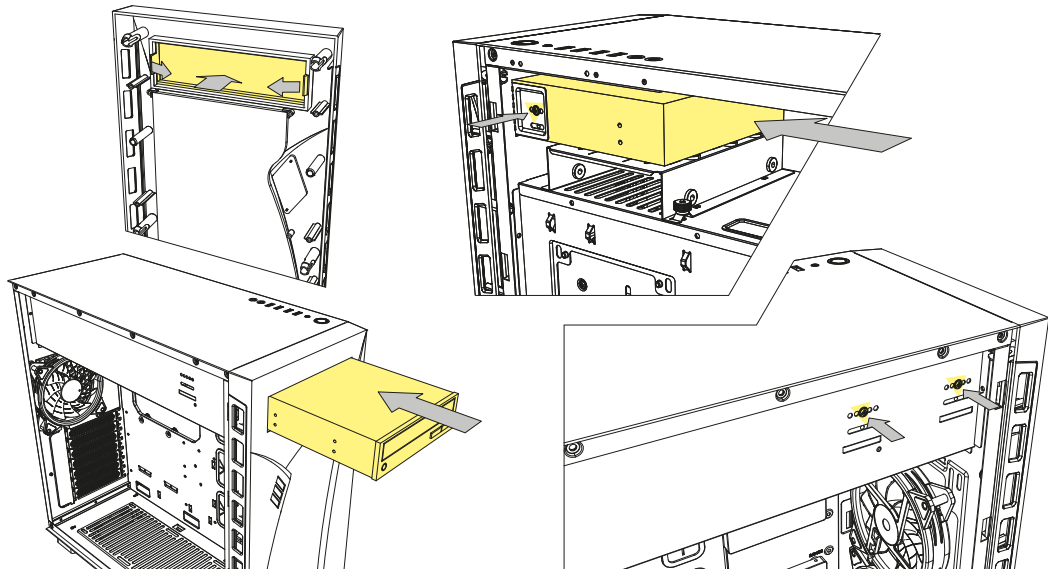

## 3.5" External Device Installation

- Einbau 3,5"-Laufwerk (Extern)
- Installation du périphérique externe de 3,5"
- Installazione unità esterna da 3,5"
- Instalación externa de dispositivo 3,5"
- Instalação de dispositivo externo 3,5"
- Installatie 3,5" apparaat (extern)
- 3,5" zewnętrzny montaž urządzeń
- 3,5" külső eszköz beszerelhetőség
- Instalace externí 3,5" jednotky
- 3.5" 外接装置安裝
- 3.5 インチ外付けデバイスの取付け

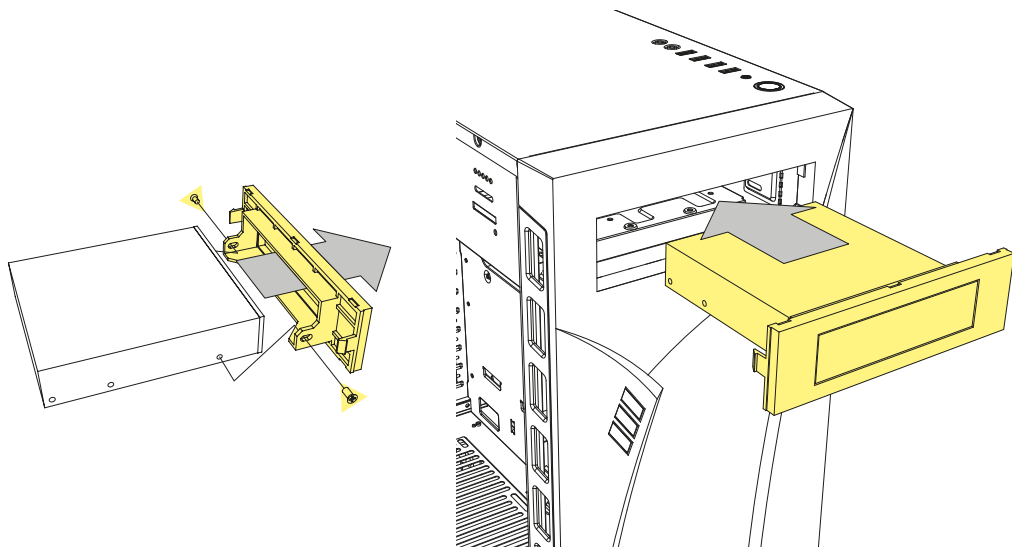

# 3.5" HDD Installation

- Einbau 3,5"-HDD
- Installation du disque dur de 3,5"
- Installazione HDD da 3,5"
- Instalación de 3,5" HDD
- Instalação HDD 3,5"
- Installatie 3,5" HDD
- 3,5" montaž dyskóv
- 3,5" HDD beszerelhetőség
- Instalace 3,5" HDD
- 3.5" 硬盘安装
- 3.5 インチハードディスクの取付け

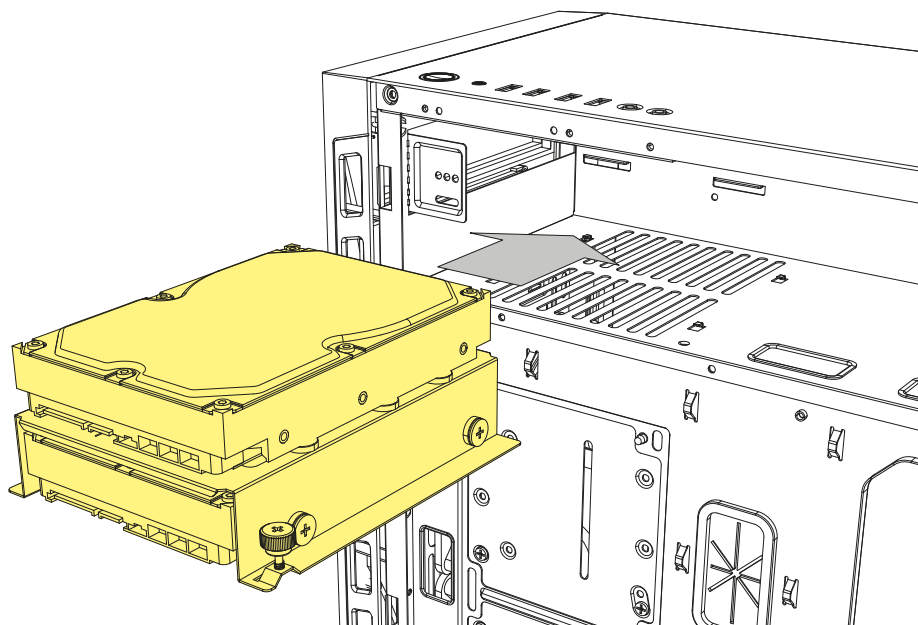
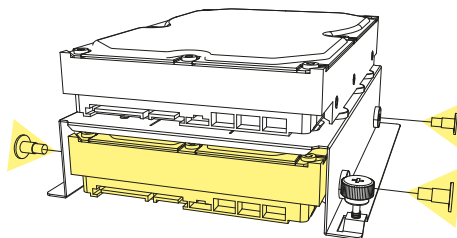
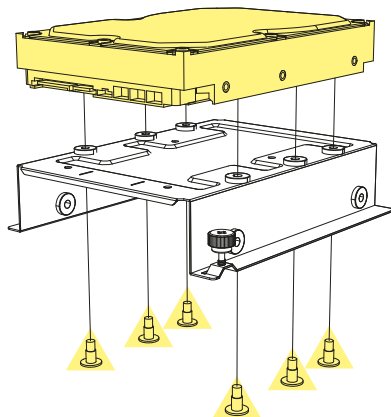
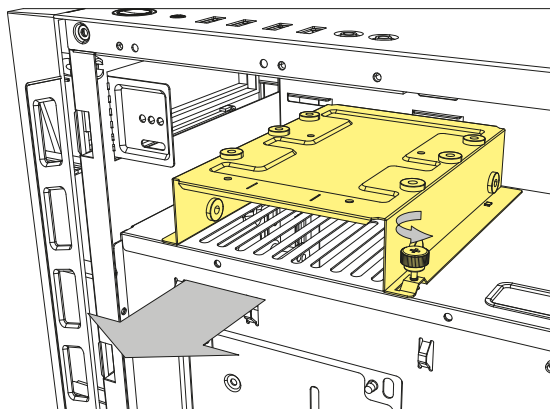

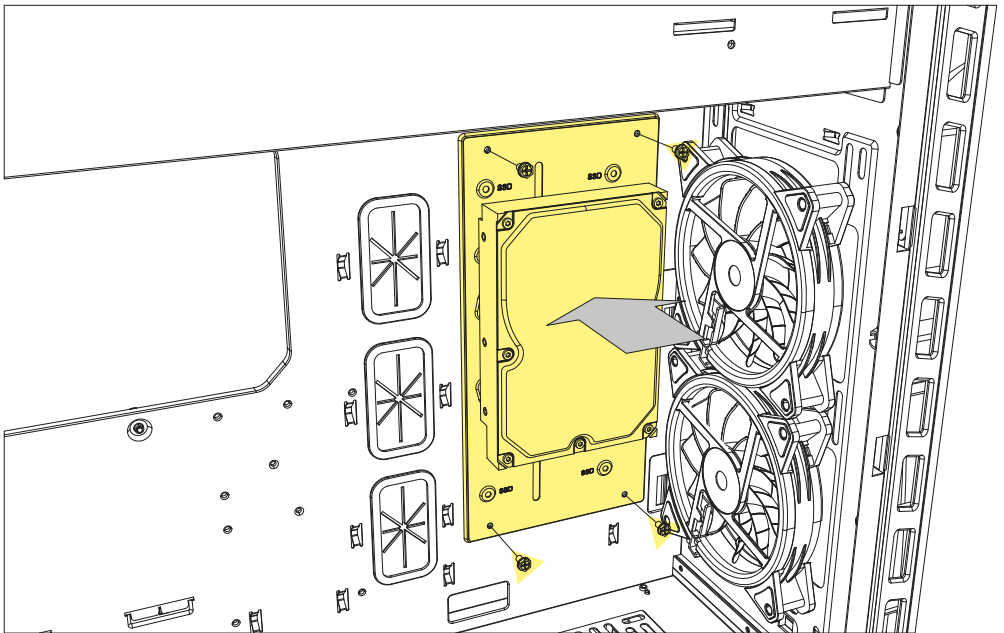
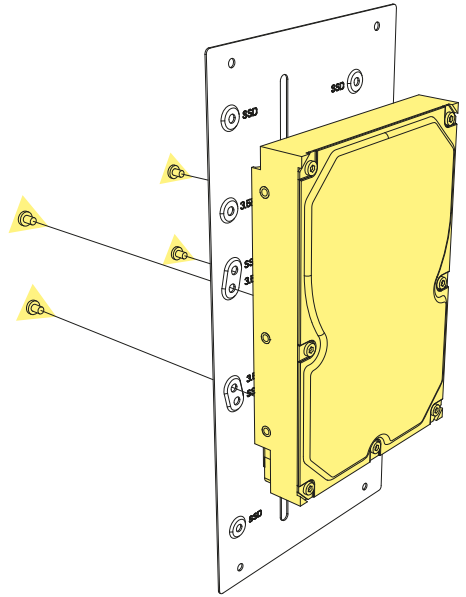
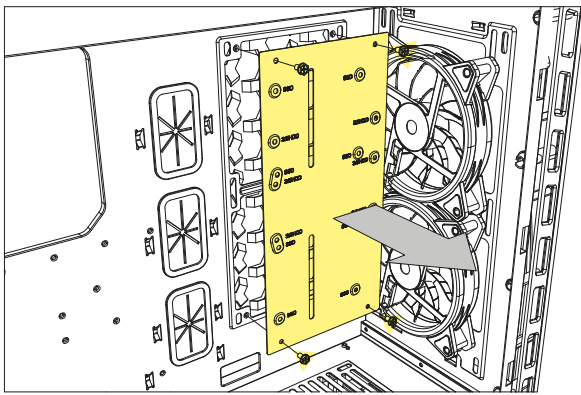

# 2.5" HDD/SSD Installation

- Einbau 2,5"-HDD/SSD
- Installation disque dur/SSD
- Installazione HDD/SSD da 2,5"
- Instalación de 2,5" HDD/SSD
- Instalação HDD/SSD 2,5"
- Installatie 2,5" HDD/SSD
- 2,5" montáz HDD/SSD
- 2,5" HDD/SSD beszerelhetőség
- Instalace 2,5" HDD/SSD
- 2.5" 硬碟/SSD 安裝
- 2.5 インチ HDD/SSD の取付け

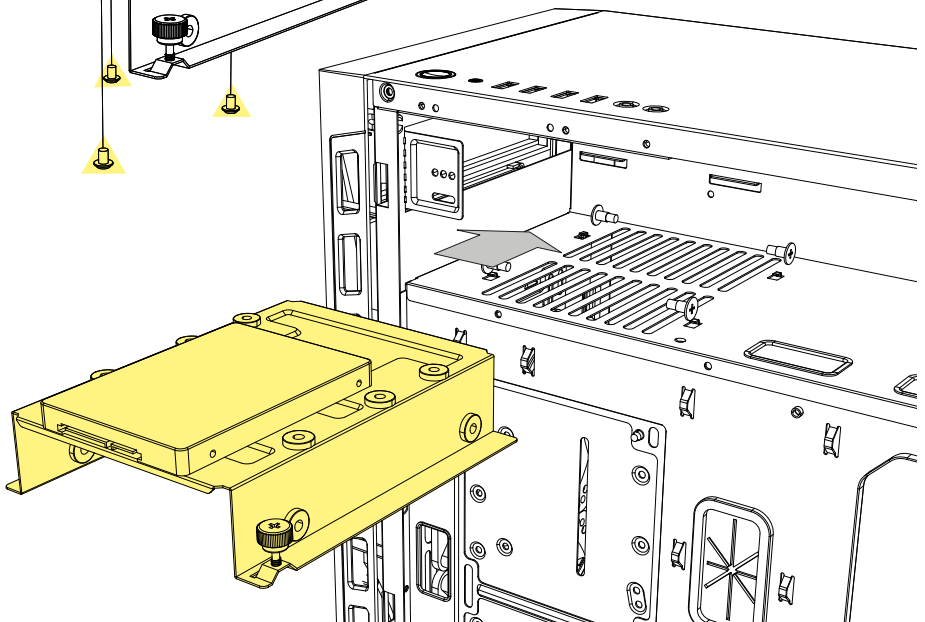
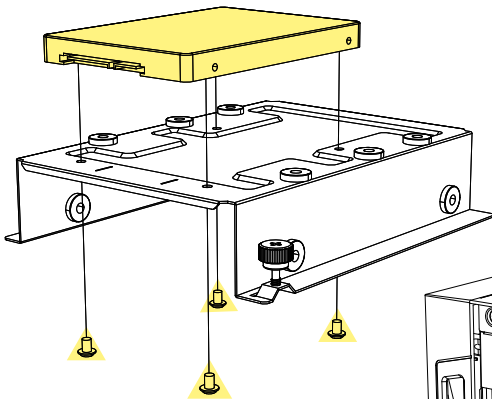
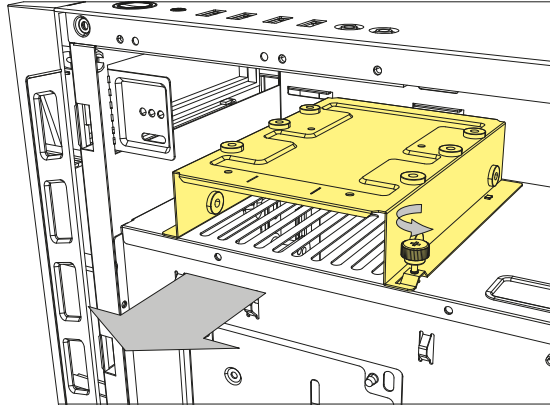

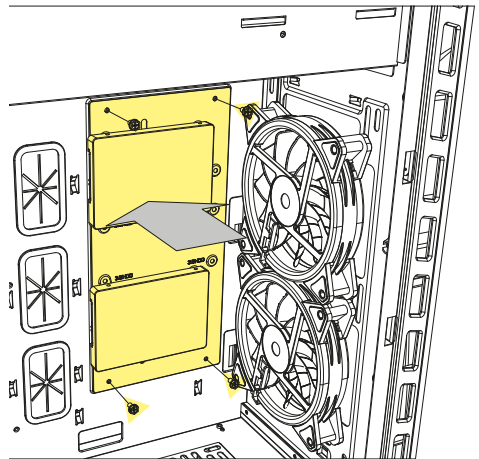
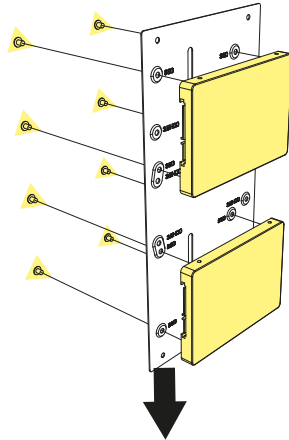
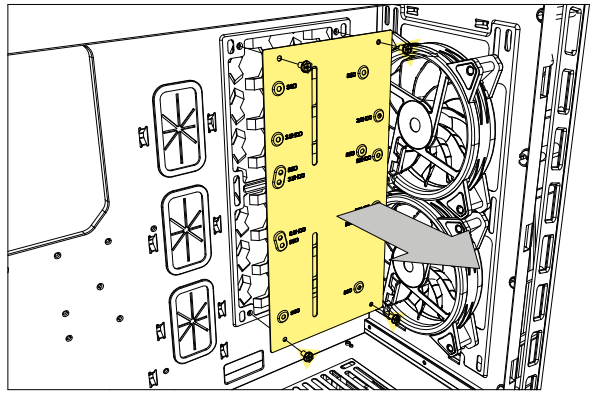
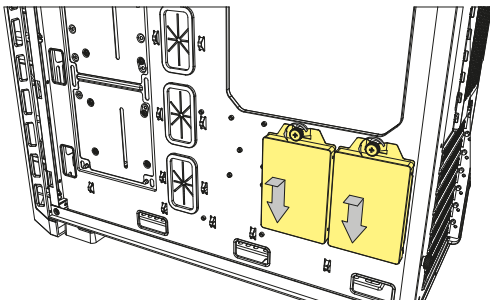
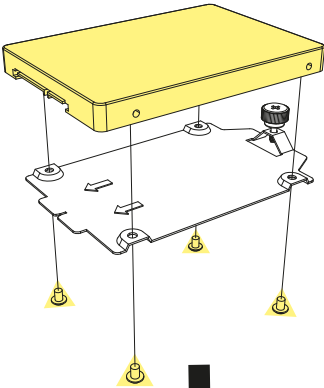
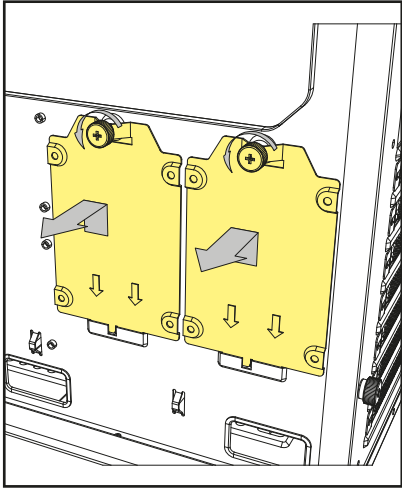

# Add-On Cards Installation

- Einbau Erweiterungskarten
- Installation des cartes d'extension
- Installazione di schede aggiuntive
- Instalación de tarjetas adicionales
- Instalação de cartões adicionais
- Installatie uitbreidingskaarten
- Montáž kart rozszerzeń
- Bővítőkártya beszerelhetőség
- Instalace karet na základní desku
- 介面卡安裝
- 増設カードの取付け

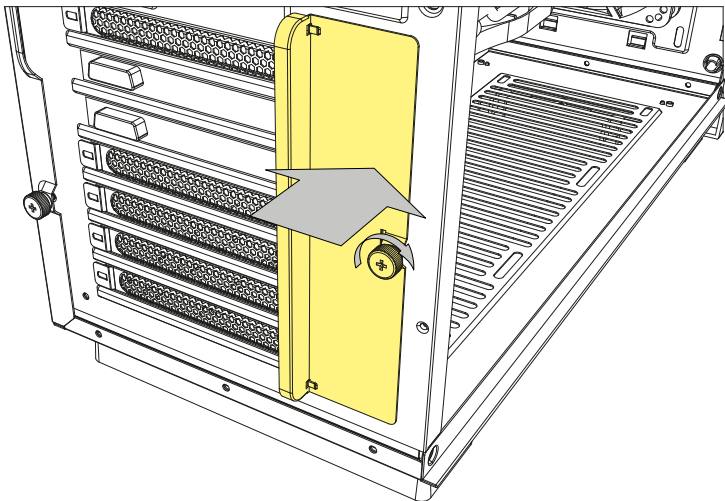
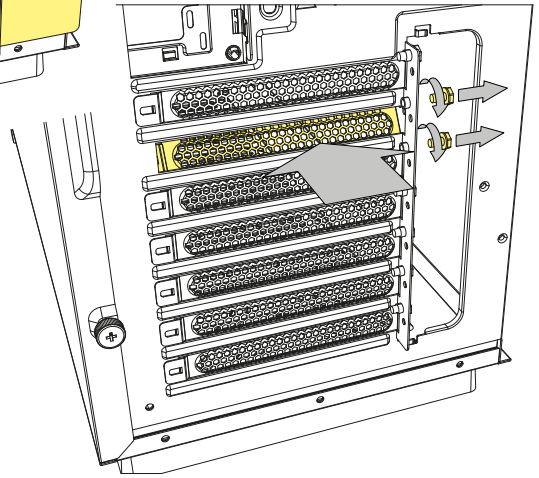
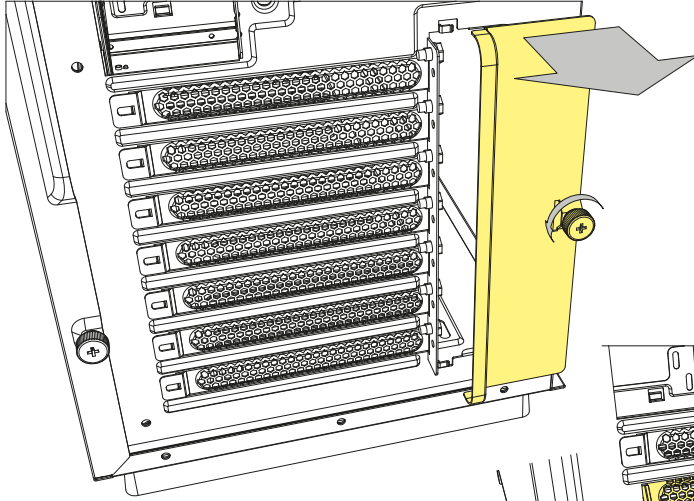



# Extra Graphics Card Support

- Zusätzlicher Grafikkartenhalter
- Support supplémentaire pour cartes graphiques
- Supporto aggiuntivo per scheda grafica
- Soporte extra para tarjeta gráfica
- Suporte extra para placas gráficas
- Ondersteuning voor extra grafische kaarten

- System do podtrzymywania kart graficznych
- Extra grafikus kártya támogatás
- Podpora grafických karet
- 顯示卡支撐架
- グラフィックカードの増設に対応

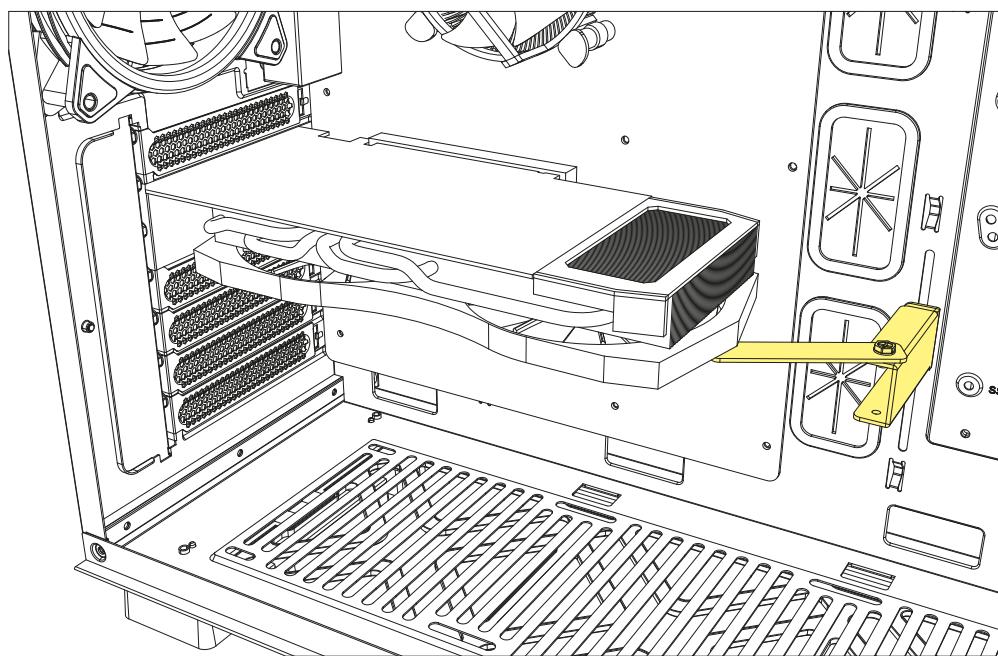
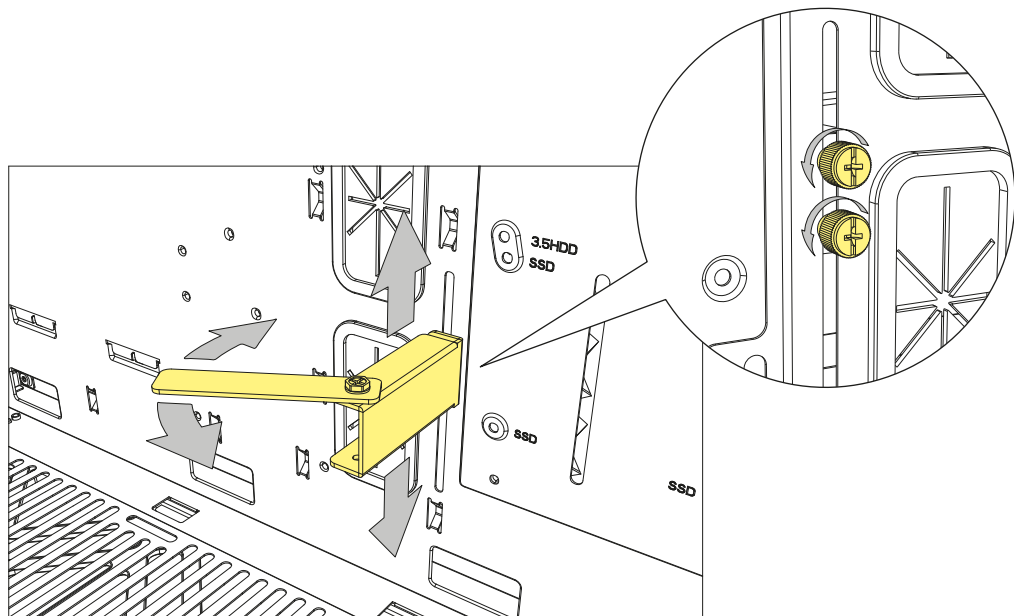

# Detachable Dust Filter

- Herausnehmbarer Staubfilter
- Filtre anti-poussière amovible
- Filtro antipolvere rimovibile
- Filtro de polvo desmontable
- Filtro de poeira destacável
- Afneembaar stoffilter

- Odczepialny filtr przeciwkurzowy
- Levehető porszűrő
- Oddeliteľný prachový filter
- 可拆卸式防塵濾網
- 着脱式ダストフィルター

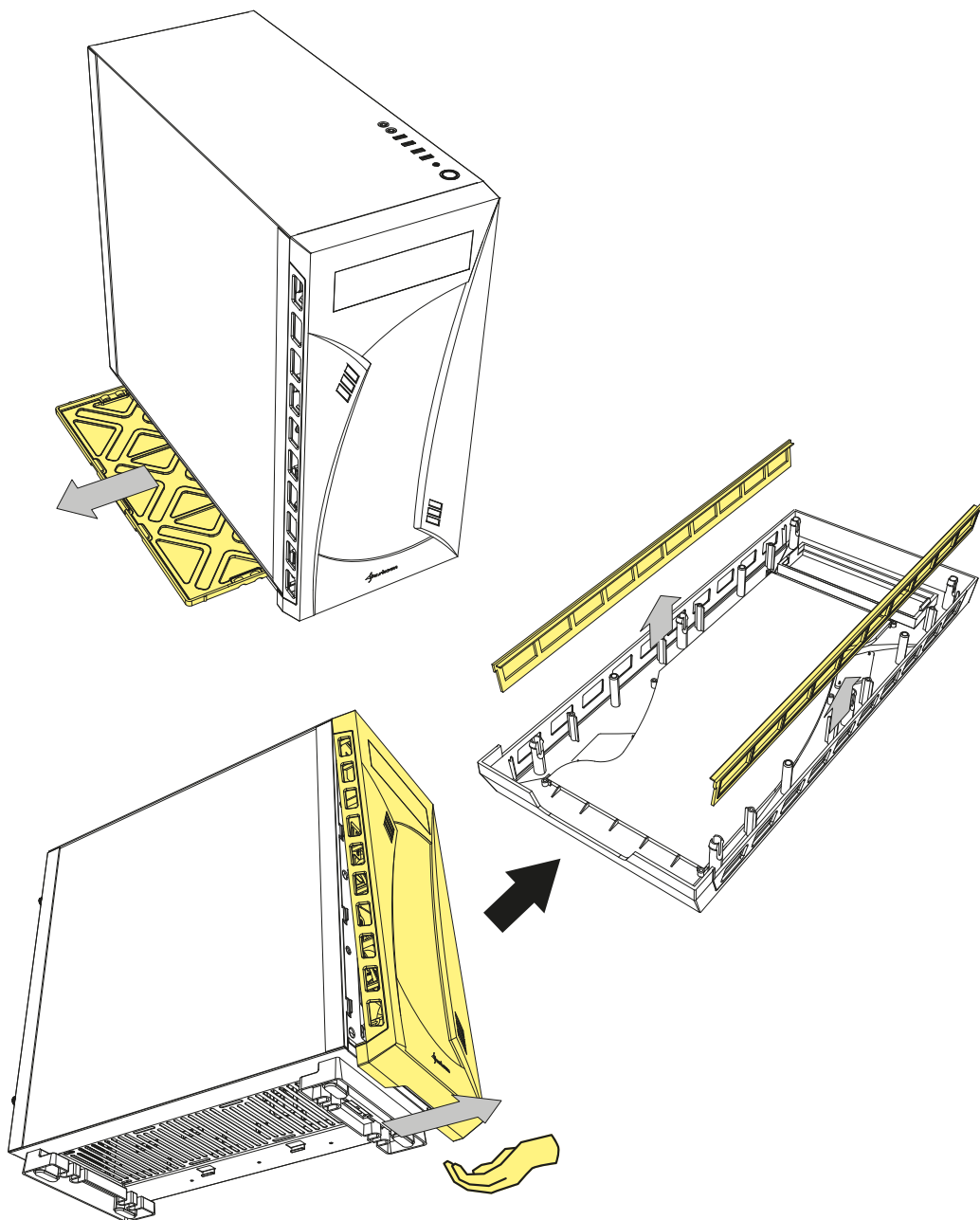

# Front Panel Radiator Installation

- Radiatoreinbau Gehäusefront
- Installation du radiateur du panneau frontal
- Installazione del radiatore sul pannello frontale
- Instalación de radiador en el panel frontal
- Instalação do radiador no painel frontal
- Voorpaneel radiator installatie
- Montáž chlodyni na panelu przednim
- A radiátor felszerelése az előlő panelre
- Instalace chladiče na přední panel
- 機殻前板水冷排安裝
- フロントパネルラジエーターの設置

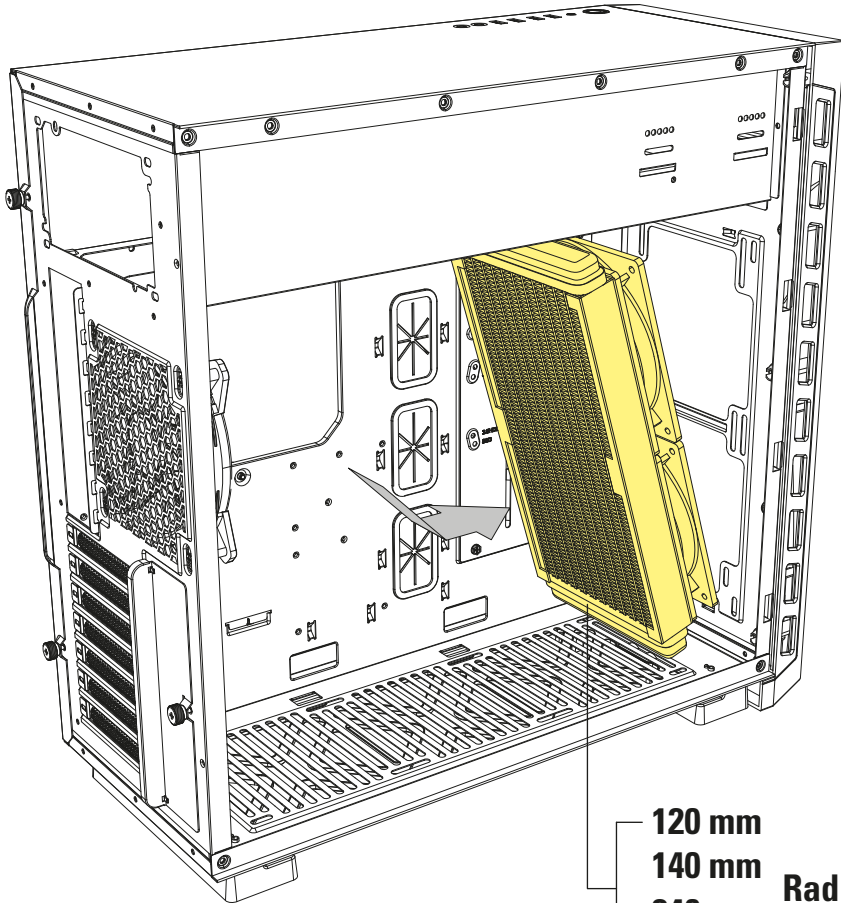

# Side Panel Radiator Installation

- Radiatoreinbau Seitenteil
- Installation du radiateur du panneau latéral
- Installazione del radiatore sul pannello laterale
- Instalación de radiador en el panel lateral
- Instalação do radiador no painel lateral
- Zijpaneel radiator installatie
- Montaż chłodnicy na panelu bocznym
- A radiátor felszerelése az oldalsó panelre
- Instalace chladiče na boční panel
- 機板側水冷排安裝
- サイドパネルラジエーターの設置

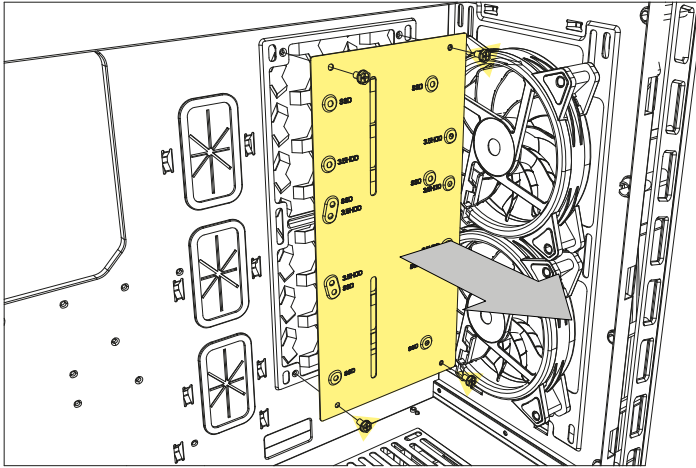

**If HDD/SSD mounting cover is removed, 2x 120 mm fans or 240 mm radiator can be installed on side panel.**

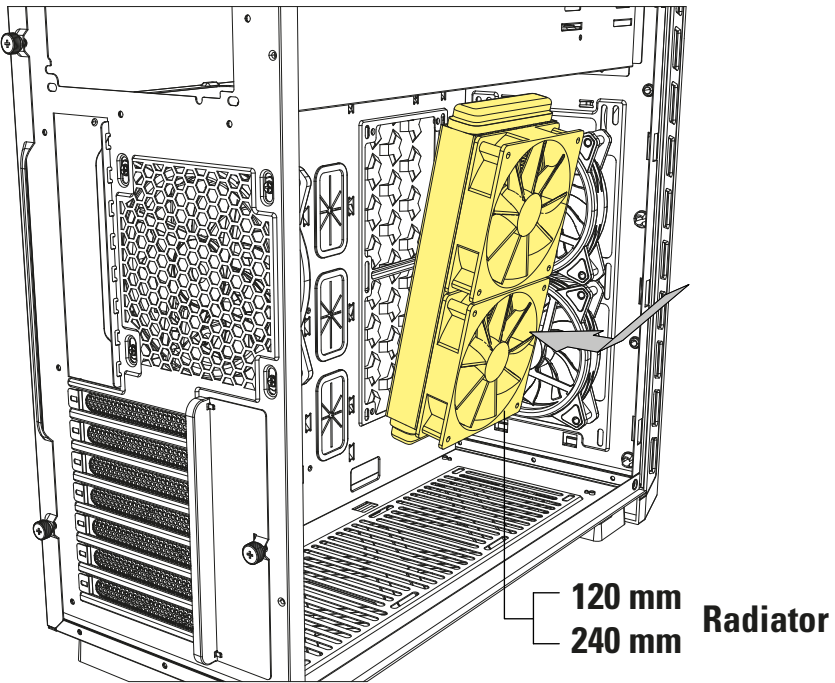

# Bottom Panel Fan/Radiator Installation

- Lüfter-/Radiatoreinbau Gehäuseboden
- Installation du ventilateur/radiateur du panneau inférieur
- Installazione delle ventole/radiatore sul pannello inferiore
- Instalación de ventilador/radiador en el panel inferior
- Instalação do ventilador/radiador no painel inferior
- Bodempaneel fan/radiator installatie
- Montáž ventilátor/chladičny na panelu dolným
- A ventilátor/radiátor felszerelése az alsó panelre
- Instalce ventilátor/chladiče na dolní panel
- 機殻底板風扇/水冷排安裝
- ボトムパネルファン/ラジエーターの設置

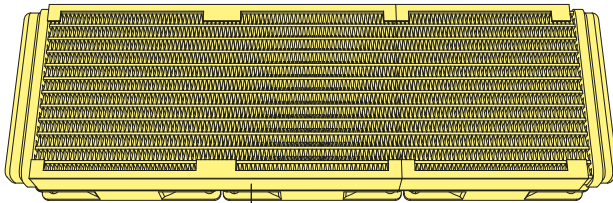
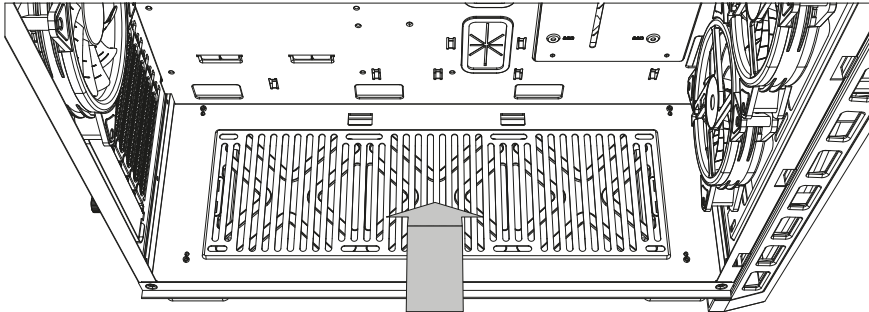
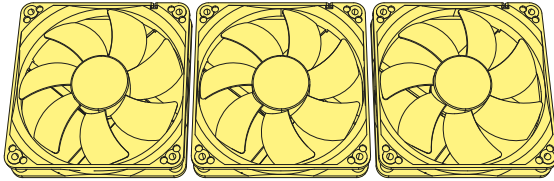
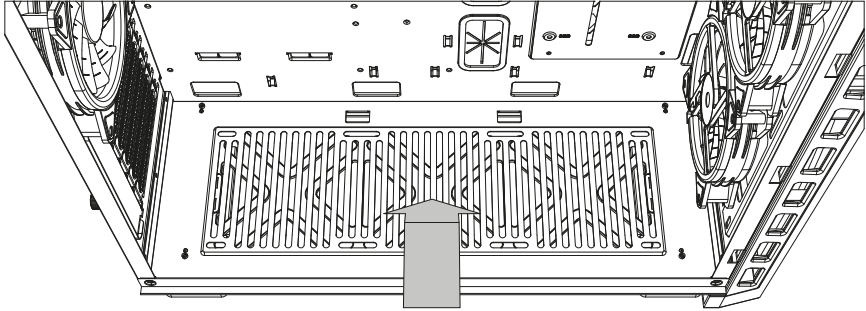

120 mm  
240 mm Radiator  
360 mm

**Internal USB 3.0 connection to mainboard may conflict  
with space for radiator. Check before installation.**

# Rear Panel Radiator Installation

- Radiatoreinbau Gehäuserückseite
- Installation du radiateur du panneau arrière
- Installazione del radiatore pannello posteriore
- Instalación de radiador en el panel posterior
- Instalação do radiador no painel traseiro
- Achterpaneel radiator installatie
- Montaz chlôdnicy na panelu tylnym
- A radiátor felszerelése a hátsó panelre
- Instalace chladiče na zadní panel
- 機殻後板水冷排安裝
- リアパネルラジエーターの設置

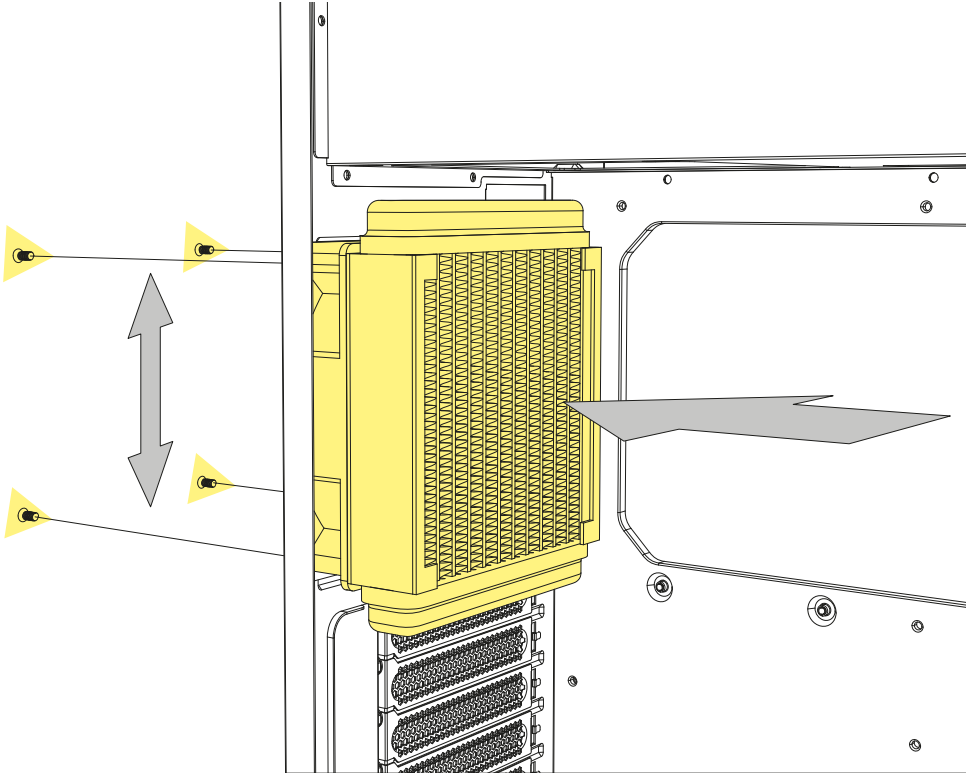

**120 mm Radiator**

# Addressable RGB Hub

- Mainboardabhängige LED-Steuerung
- Contrôleur RVB de carte mère adressable
- Controller addressable RGB della scheda madre
- Control RGB accessible en lan placa base
- Control RGB endereçâvel da placa mãe
- Mainboard adresseerbare RGB-besturing
- Kontrola adresowania RGB do płyty głównej
- Mainboard címvezető RGB vezérlés
- Adresní ovládací prvek RGB na základní desce
- 主機板幻影RGB控制
- メインボードのアドレス指定可能なRGBコントロール

## Addressable RGB LED Fans/ Addressable LED Strips

### Mainboard Addressable RGB Pins

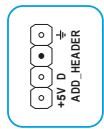

or

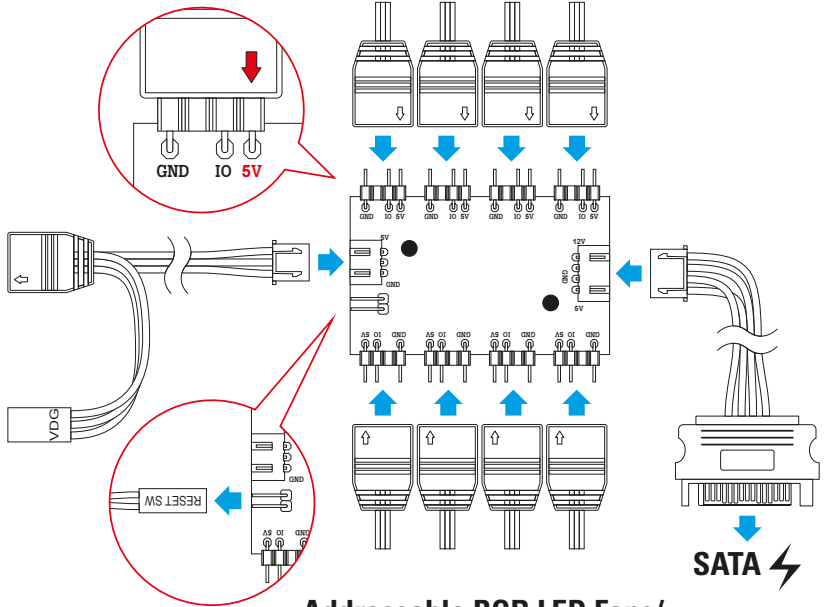
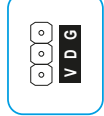

## Addressable RGB LED Fans/ Addressable LED Strips

- Manuelle LED-Steuerung
- Contrôleur RVB de carte mère manuel
- Controllo manuale RGB
- Control RGB Manual
- Controle RGB Manual
- Handmatige LED-regeling

- Ręczna kontrola RGB
- Kézi LED vezérlés
- Ruční ovládání LED
- 手動RGB 控制
- マニュアルLED制御

## Addressable RGB LED Fans/ Addressable LED Strips

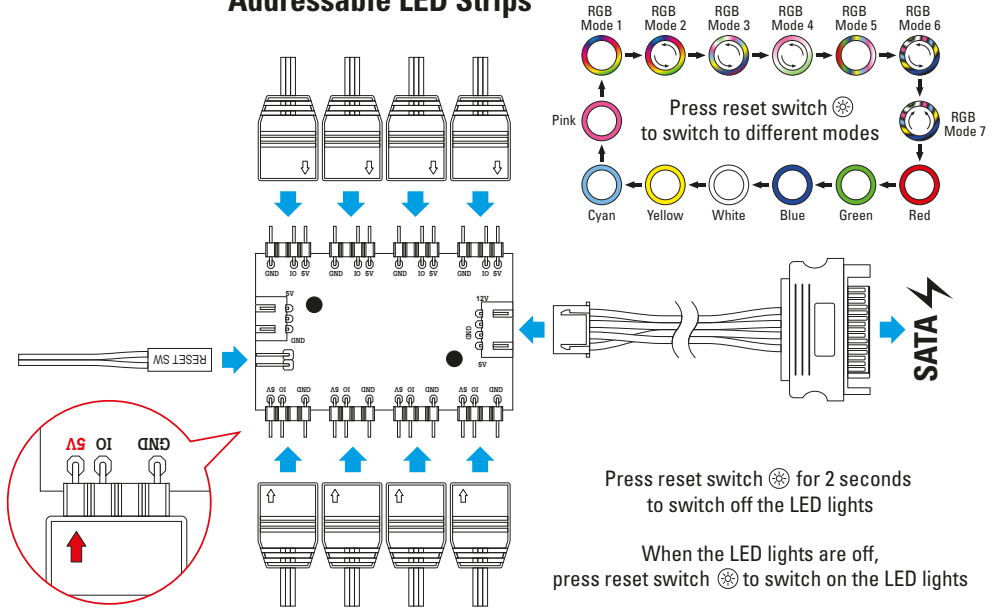

## Addressable RGB LED Fans/ Addressable LED Strips



## Legal Disclaimer

For potential loss of data, especially due to inappropriate handling, SHARKOON assumes no liability. All named products and descriptions are trademarks and/or registered trademarks of the respective manufacturers and are accepted as protected. As a continuing policy of product improvement at SHARKOON, the design and specifications are subject to change without prior notice. National product specifications may vary. All rights reserved especially (also in extracts) for translation, reprinting, reproduction by copying or other technical means. Infringements will lead to compensation. All rights reserved especially in case of assignation of patent or utility patent. Means of delivery and technical modifications reserved.

## Disposal of your old products

Your product is designed and manufactured with high quality materials and components, which can be recycled and reused.



When this crossed-out wheeled bin symbol is attached to a product, it means the product is covered by the European Directive 2012/19/EU. Please be informed about the local separate collection system for electrical and electronic products. Please act according to your local rules and do not dispose of your old products with your normal household waste. The correct disposal of your old product will help prevent potential negative consequences to the environment and human health.

## Rechtliche Hinweise

Für evtl. auftretenden Datenverlust, insbesondere durch unsachgemäße Handhabung, übernimmt SHARKOON keine Haftung. Alle genannten Produkte und Bezeichnungen sind Warenzeichen und/oder eingetragene Warenzeichen der jeweiligen Hersteller und werden als geschützt anerkannt. Als ein Teil von SHARKOONs Politik der fortwährenden Produktverbesserung unterliegen Produktdesign und -spezifikationen Änderungen ohne vorherige Ankündigung. Die Spezifikationen können in verschiedenen Ländern variieren. Alle Rechte vorbehalten, insbesondere (auch auszugsweise) die der Übersetzung, des Nachdrucks, der Wiedergabe durch Kopieren oder ähnliche Verfahren. Zuwiderhandlungen verpflichten zu Schadenersatz. Alle Rechte vorbehalten, insbesondere für den Fall der Patenterteilung oder GM-Eintragung. Liefermöglichkeiten und technische Änderungen vorbehalten.

## Entsorgung Ihres alten Gerätes

Ihr Gerät wurde unter Verwendung hochwertiger Materialien und Komponenten entwickelt und hergestellt, die recycelt und wiederverwendet werden können.



Befindet sich dieses Symbol (durchgestrichene Abfalltonne auf Rädern) auf dem Gerät, bedeutet dies, dass für dieses Gerät die Europäische Richtlinie 2012/19/EU gilt. Informieren Sie sich über die geltenden Bestimmungen zur getrennten Sammlung von Elektro- und Elektronik-Altgeräten in Ihrem Land. Richten Sie sich bitte nach den geltenden Bestimmungen in Ihrem Land, und entsorgen Sie Altgeräte nicht über Ihren Haushaltsabfall. Durch die korrekte Entsorgung Ihrer Altgeräte werden Umwelt und Menschen vor möglichen negativen Folgen geschützt.

**SHARKOON Technologies GmbH**  
Siemensstraße 38  
35440 Linden  
Germany

© **SHARKOON Technologies 2018**

[info@sharkoon.com](mailto:info@sharkoon.com)  
[www.sharkoon.com](http://www.sharkoon.com)