

RECUMBENT

RB-5



THE RB-5 RECUMBENT
EXERCISE BIKE:

DESIGNED USER COMFORT
WHILST NOT COMPROMISING
ON PERFORMANCE.

PRODUCT ID
SKU : 20450
EAN : 5412002205409



The RB-5 recumbent exercise bike is not only incredibly stylish looking with its sleek and classic easy step through design, but the reworked ergonomic design makes it perfect for longer workouts with reduced chance of injury.

The heavy 11 kg flywheel produces a consistent, smooth and quiet pedalling action while the extra wide 41cm multi-adjustable seat, wide pedals and tilting console provide a really comfortable workout position for a wide range of different users.

The low step-through and sturdy fixed handles either side of the console also make this bike an excellent choice for those with limited mobility.

The upright back support and integrated hand rests offer an easy and comfortable riding position, and makes the RB-5 incredibly easy to use and train with.

The digital resistance range available on the RB-5 allows you to easily select and adjust the digital resistance directly from the console, and offers an intensity range of 10 to 400 Watts in 5 Watt interval steps, meaning you can accurately specify your desired intensity.

Cardio training is easily programmed using Heart Rate controlled Target Zones. Just strap on the optional Bluetooth HR strap, and link automatically to the console for a stable and more accurate heart rate registration.



The RB-5 provides an automatically controlled resistance range of 10 to 400 Watts adjustable in 5 Watt interval steps, and means you can get a far more precise workout, and offers a wide range of intensities for all users.

Personal-Coaching: a multifunctional LCD, monitoring all functions simultaneously : RPM, timer, distance, calorie burn, watt, heart rate, 24 levels, 12 time-intervals, and 12 preprogrammed courses.

SPECS

Max user limit	150 kg
Dimensions	140 x 67 x 140 cm
Weight	60 kg
Flywheel	11 kg
Drive	Poly-V belt
Adjustable seat	v
Adjustable h'bar	v
Resistance levels	24
Timer	v
Speed	v
Distance	v
Calories	v
WATT	v
HR	v
Cooling fan	v
Kinomap	

AVAILABLE OPTIONS

- 20222 Protective Floormat 100 x 200 cm
- 20409 Bluetooth Cheststrap

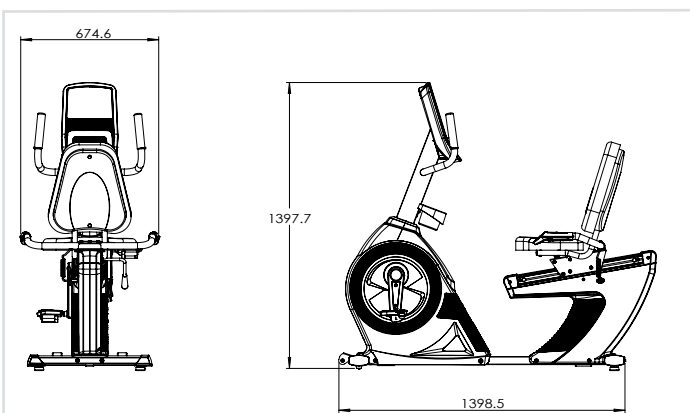

DKN-International
Luitenant Lippenslaan 60
2140 Antwerpen
Belgium

BE-0474.286.250

Tel + 32 52 210315
sales@dkn-technology.com