

ASSEMBLY INSTRUCTION

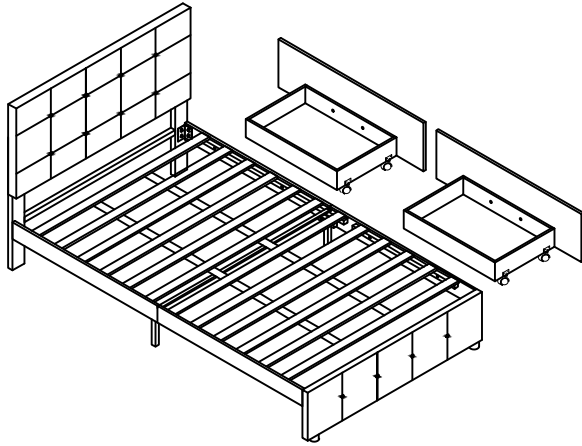

TIPS

1. Please read the instructions fully before assembly. These instructions include important information which could ensure correct assembly. We have been working on providing high quality products for you. However, in the rare instance that your product is defective, missing parts or there are some issues, please don't hesitate to contact our customer service to submit parts requirements, assembly suggestion, or warranty claims, and we will give the best solution as soon as possible. If necessary, we need you to provide some more clear pictures of the issue.

2. Insert the screws in holes and tighten the screws, but not too tight, 70%~80% is ok, finally tighten all the screws. If some issues happened that some screws can not target to the hole or some parts are difficult to install, please adjust the tightness of the screws.



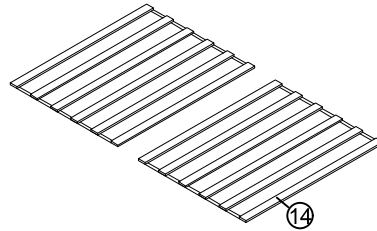
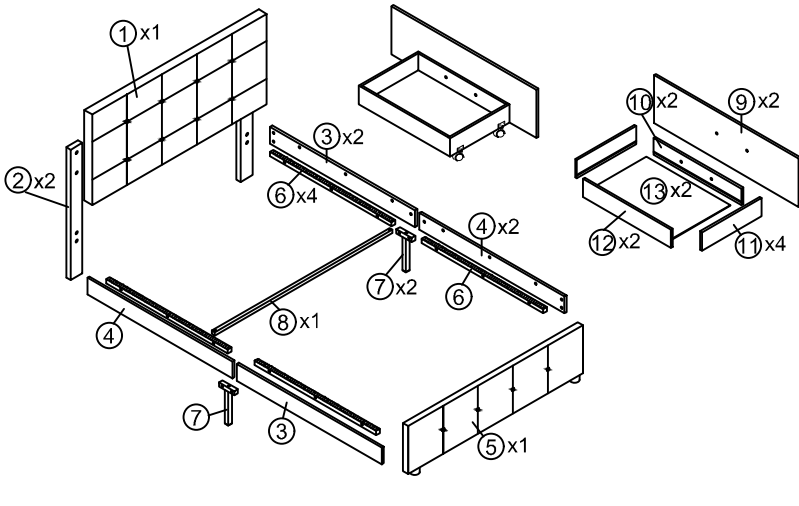



3. 2 people are recommended to finish



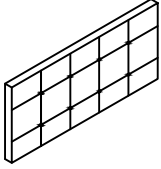

Parts List			Hardware List		
NO	ITEM	QTY	NO	ITEM	QTY
1	Head board	1	A	Allen Key 	1
2	Head board legs	2	B	Bolts (M8x50mm) 	4
3	Siderails	2	C	Bolts (M8x16mm) 	16
4	Siderails	2	D	Bolts (M8x40mm) 	18
5	Foot board	1	E	Washer 	4
6	Side rails support bar	2	F	Drawer wheel 	8
7	Side rails support legs	2	G	"7" Connector 	4
8	Cross bar	1	J	Bolts (M8x30mm) 	4
9	Drawer outer board	2	L	Nails (M4x40mm) 	2
10	Drawer board	2	M	Legs 	2
11	Drawer board	4	O	Drawer fittings 	16
12	Drawer board	2	P	Drawer fittings 	16
13	Drawer bottom board	2	Q	Nails (M3x16mm) 	24
14	Slats	12			

Part List

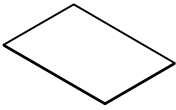
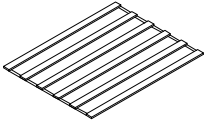
WF289083

1  Head board-1pc	2  Head board leg-2pc	7  Side rails support legs-2pcs
10  Drawer board-2pcs	11  Drawer board-4pcs	12  Drawer board-2pcs
13  Drawer bottom board-2pcs	14  Slats-12pcs	

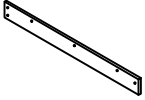
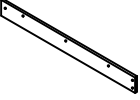
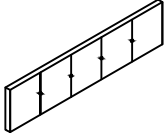
Hardware List+WF289084

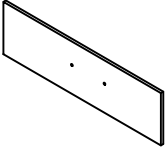

3  Side rails-2pcs	4  Side rails-2pcs	5  Foot board -1pc
6  Side rails support bar-4pcs	8  Cross bar-1pc	9  Drawer outer board-2pcs

Attention: Do not tighten the screws before completing the entire installation. If you have any difficulty with the installation process, please feel free to contact us.

Step 1 x2

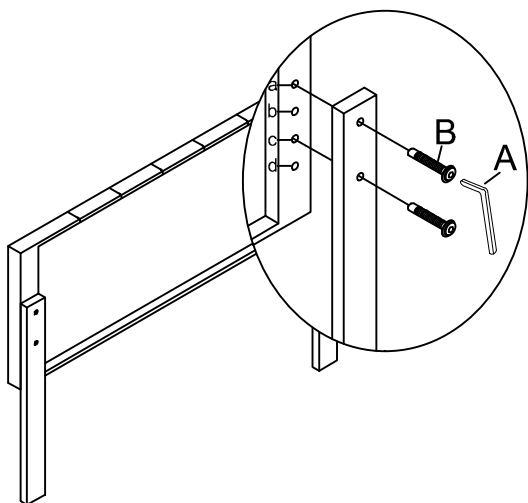
Fix the Headboard legs ② to the Headboard ① with Bolt B by using Allen key A. You can chose the hole a and c ,or b and d.





A Allen Key x 1	B Bolts x 4
	 M8X50mm

Step 2 x2

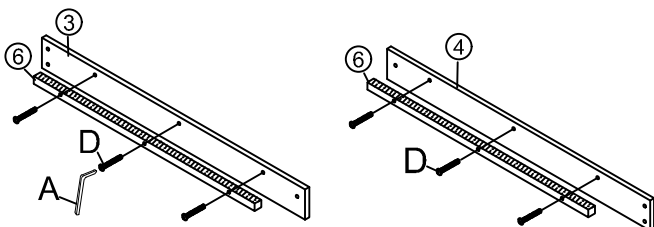
Connect Siderails ③ and ④ to Siderail support bar ⑥ with Bolts D by using Allen key A.





D Bolts x 12	Allen Key
 M8X40mm	

Step 3 x2

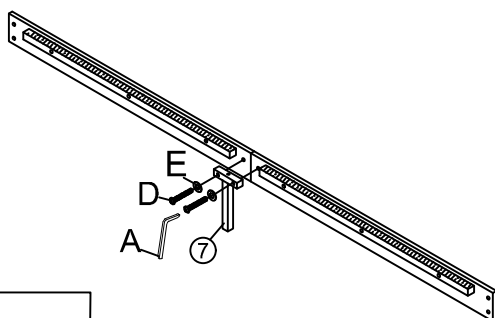
Fix the Siderail support leg ⑦ to the assembled siderail with Bolt D and Washer E by using Allen key A.







D Bolts x 4	E Washer x 4	Allen Key
 M8X40mm		

NOTICE:
Please assemble ③ and ④ together.

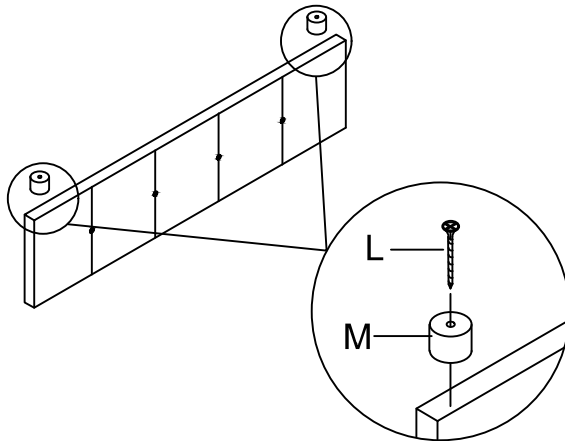
Step 4 x2

Fix the legs M to the Footboard ⑤ with Nails L by using Electric drill or Screw driver.



L Nails x 2  M4X40mm	M Legs x 2 	
---	---	---

Step 5

Fix the assembled siderail to the Headboard legs ② and footboard ⑤ with Bolt C and "7" Connector by using Allen key A.

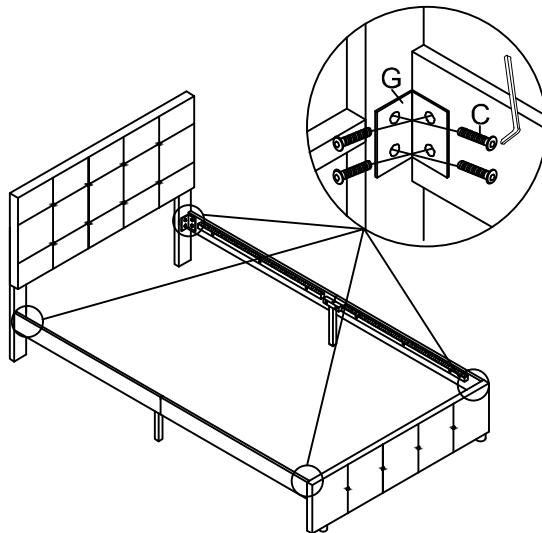



C Bolts x 16  M8X16mm	G "7" Connector x 4 	Allen Key 
--	--	--

Step 6

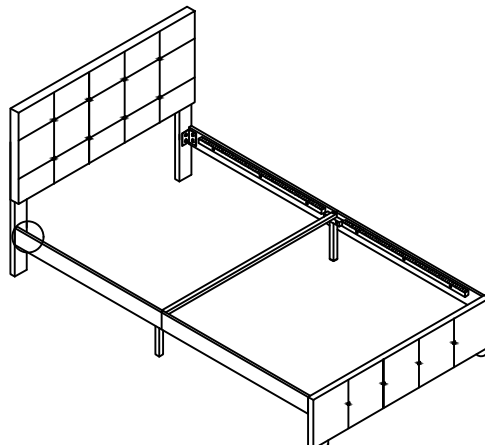
Fix the Cross bar ⑧ to the Siderails bar with Bolt D by using Allen key A.





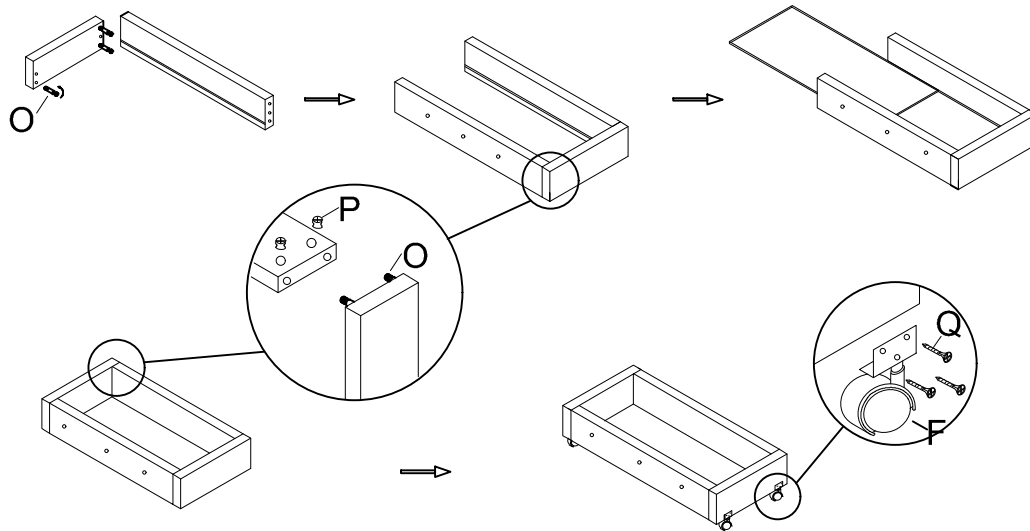

Allen Key 	D Bolts x 2  M8X40mm
--	---

Step 7

Assembled the Drawer with Drawer fittings P and O. Fix the Drawer wheel F with Nails Q by using Electric drill or Screw driver.



O Drawer fittings x 16 	P Drawer fittings x 16 	Q Nails x 24 M3X16mm 	F Drawer wheel x 8 	
---	---	--	---	---

Step 8 x2

Fix Drawer outer board ⑨ to the drawer with Bolt J by using Allen key A.

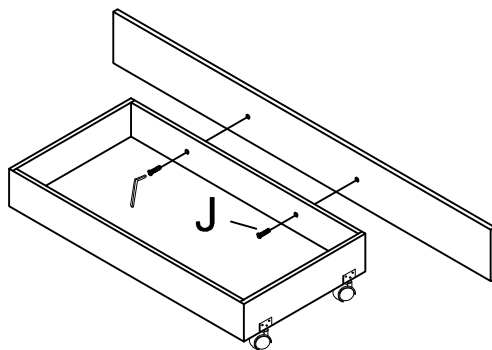

J Bolts x 4  M8X30mm

Step 9

Fix the slats ⑭ to the side support bar ⑥

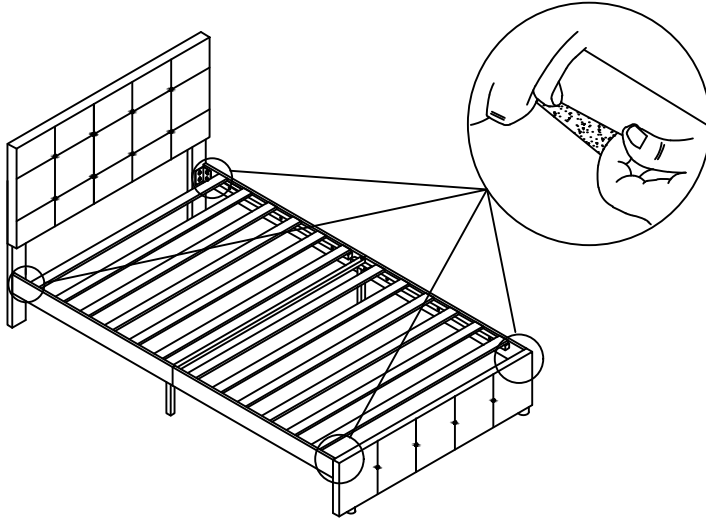

Step 10

Push the drawers into the bed, then assembly is finished.

