

Apex

Owners Manual



# CONTENTS

Contents	1
Important Safety Instructions	2
Re-cycling	3
RoHS Declaration of Conformity	3
Unpacking	4
Introduction	5
Setting up and Positioning	6
Optimum Positioning	7
Fitting the Apex 10 to a Wall or Ceiling	8
Apex 10 Fixing Configurations	9
Adjusting the Apex 10 Bracket Assembly	13
Fitting the Apex 40 to a Wall or Ceiling	14
Apex 40 Fixing Configurations	15
Grille Badge Fixing	16
Specifications	17
Guarantee and Service	18
Claims under this Guarantee	18
EC Declaration of Conformity	19
Data Protection	20
Owner Information	20

## IMPORTANT SAFETY INSTRUCTIONS

- 1. Read these instructions.**
- 2. Keep these instructions.**
- 3. Heed all warnings.**
- 4. Follow all instructions.**
- 5. Do not use this apparatus with water.**
- 6. Clean only with a dry cloth.** Great care and attention has gone into the materials chosen to produce the Apex Series. A gentle wipe with a dry, clean cloth is all that is required to remove any dust. Treat them as you would a fine piece of furniture because that is how they have been designed.
- 7. Do not block any ventilation openings.** Install in accordance with the manufacturers instructions.
- 8. Do not install near any heat source,** such as radiators, heat registers, stoves, or other apparatus (including amplifiers) that produce heat.
- 9. Only use attachments/ accessories specified by the manufacturer.**
- 10. Use only with the cart, stand, tripod, bracket, or table** specified by the manufacturer or sold with the apparatus. When a cart is used, use caution when moving the cart/ apparatus combination to avoid injury from tip-over.



- 11. Refer all servicing to qualified service personnel.** Servicing is required when the apparatus has been damaged in any way, such as power supply cord or plug is damaged, liquid has been spilled or objects have fallen onto the apparatus, the apparatus has been exposed to rain or moisture, does not operate normally or has been dropped.
- 12. This apparatus shall not be exposed to dripping or splashing water** and that no object filled with liquids such as vases shall be placed on the apparatus.
- 13. This exclamation point within an equilateral triangle** is intended to alert the user to the presence of important maintenance (servicing) instructions in the literature accompanying the appliance.



# SAFETY INSTRUCTIONS FOR FIXING YOUR APEX LOUDSPEAKERS TO A WALL



**WARNING:** For safety reasons do not attempt to fix these speakers to your wall if you are unsure of your ability to provide a secure and safe fixing. You will need to determine where to fit the bracket and the structure of the wall. If unsure, please obtain the services of a competent qualified trades-person.



**WARNING:** Ensure that there are no gas/ water pipes, or electricity cables running behind where the wall bracket is going to be secured. Work from secure steps and avoid trailing wires.

## RE-CYCLING

Correct Disposal of Waste Electrical and Electronic Equipment (WEEE) by User in Private Households in the EU.



This symbol on the product or accessories indicates that they must not be disposed of with your household wastes throughout the EU. To prevent possible harm to the environment or human health from uncontrolled waste disposal, recycle it responsibly to promote the sustainable reuse of material resources. Instead it is your responsibility to dispose of your waste equipment by handing it over to a designated collection point for recycling WEEE. The separate collection and recycling of your waste equipment will help conserve natural resources and ensure that it is recycled in a manner that protects human health and the environment.

For more specific information about where you can take your equipment for recycling please contact your local city/council office, your local waste disposal service or the outlet where you purchased your Apex product.

## ROHS DECLARATION OF CONFORMITY

Directive 2002/95/EC of the European Parliament and of the Council on the reduction of the use of certain hazardous substances in electrical and electronic equipment, January 2003.



### Background

The RoHS directive restricts the use of Lead (Pb), Cadmium (Cd), Mercury (Hg), hexavalent Chromium (CrVI), polybrominated biphenyl (PBB) compounds, and polybrominated diphenyl ether (PBDE) compounds in electrical and electronic equipment sold in the European Union.

# UNPACKING

Due to the shape and the polished finish of the product, care must be taken when handling your new Apex Series Loudspeaker.



Care must be taken when handling the table top stand/ wall plate. This, the accessories and the grille should be removed from the packaging before removing and unpacking the loudspeaker.



Great care must be exercised at all times to ensure the driver(s) and tweeter are not damaged during unpacking and when finally siting in the room. Any physical damaged caused to the drive unit by not complying with this requirement will not be covered by warranty.

Within the packaging you will find the following:

## Apex 10

- Cabinet
- Table top stand/ wall mounting plate.
- Grille in separate carton.
- Accessory pack. Inc: Short and long bolts, extension pole, adhesive feet and hex key
- Wall fixing template

## Apex 40

- Cabinet (with bracket attached)
- Grille in separate carton.
- Accessory pack. Inc: Grub screws, grub screw covers, adhesive feet, badge and hex key.
- Wall fixing template

To remove the Apex products from the carton, place some protective material on the floor/ table top and having removed any loose items (Table top stand, accessory pack, grille) from the top of the packaging, carefully invert the carton. Also see the icons on the carton. Gradually pull the carton upwards to expose the underside of your Apex product. Remove fixing tape from the bag(s) and expose the cabinet.

The Apex 10 will arrive with the clamp arms, pivot and clamp screw in situ. Assemble the other components in accordance with your requirements following the guides on pages 9-12. This assembly may need to be flipped over depending on the rotation of the speaker.

The Apex 40 will arrive with the wall bracket attached to the cabinet. To secure the Apex 40 to a wall, please refer to pages 14 & 15.

## INTRODUCTION

Congratulations and thank you for your purchase of the loudspeaker from the Apex Series. We are confident they will provide years of enjoyment and pleasure as only high quality components have been used throughout.

The sophisticated new Apex Series introduces revolutionary new technologies, honed to produce the highest standards of performance and build quality. A unique blend of versatility, performance and style, designed to excel in the most demanding audio or home theatre based systems.

New C-CAM® bass drivers have been specially developed for Apex, further enhanced by the introduction of the high performance RST cone geometry. All bass drivers feature vented, die-cast aluminium chassis and large diameter, high power voice coils. Using advanced FEA modelling, the 25mm C-CAM gold dome tweeter has been optimised to eclipse performance of previous designs with crisp, detailed high frequencies beyond 35kHz.

The rigid die-cast alloy cabinet, baffle and drive units are bolted together using the innovative through bolt fixing technology adopted in Monitor Audio's range topping Platinum Series. The through bolting system provides uniform mechanical pressure, which ties the whole speaker assembly together and doubles as a rigid bracing system to keep the cabinet stiff and free from resonance. These features provide enhanced mid-band clarity and resolution by limiting vibration from the driver and cabinet which could adversely add colouration and affect sound quality. All component parts are constructed from die-cast or machined metal alloys, providing extreme rigidity and assured high performance. HiVe® port design has been introduced to Apex, resulting in clean powerful, punchy bass with superior transient response.

Heavy duty bracket systems have been designed for optimum flexibility and ease of use. Die-cast or machined from heavy duty aluminium/ zinc alloy, they provide the ultimate in stability whilst offering greater flexibility with numerous installation options available.

Stylish magnetic grilles have been designed with no visible fixings, providing a simplistic and sleek appearance.

Apex is a true master-class of engineering excellence, delivering class leading performance maintaining Monitor Audios' fine heritage of award winning sound.



Apex

## SETTING UP AND POSITIONING

Although position and suitability will have been considered prior to purchasing the Apex speakers, this section will guide you through optimising their positioning and set up. An illustration is provided on page 7 to show optimum positions. For instructions on assembling the brackets and securing them to a wall or ceiling, please refer to pages 8-15.

### Positioning - Front Speakers

The tweeter of the centre channel is best pointed towards the listener's ears to help direct the sound and should be the first speaker you position in your home theatre room. The centre channel's job is to anchor dialogue and other on-screen sounds to the screen. Typically, As much as 60% of a movie sound track comes through the centre channel .

The centre channel can be placed either above or below, and as close to your TV screen as possible. If positioned in/ on a cabinet or sitting on top of the TV itself ensure that the front edge of the speaker is aligned with the front edge of the TV or shelf. Where possible, the height of the centre channel's tweeter from the floor, should be close to the height of your front speakers' tweeter as possible — ideally, within about 600mm.

When placing the loudspeakers on the wall around a plasma/ LCD TV, the left and right speakers ideally need to be between 22 & 30° to the left and right of the listening position, with the tweeters at approximate ear level, or at least aimed towards the listening position.

The Apex 40 can be rotated left/ right (when mounted vertically) or up/ down when mounted horizontally. The Apex 10 can be adjusted in all directions regardless of mounting position. Refer to pages 13 & 15.

### Positioning - Surround Speakers

Ideally, the primary pair of surround speakers should be placed to the left and right of the listening position — either in line with it, or just behind it (90 - 110°). If it is a 6.1 channel or 7.1 channel system with more than two surround speakers, or if side placement isn't available in a 5.1 channel system, consider placement behind your listening position, facing the front of the room (135 - 150°).

Surround speakers should be placed high enough so that the drivers do not fire directly at the listening position — one rule of thumb is to place them at ear level while standing. If the surround speakers fire directly at the listening position, they can overpower your front speakers.

If the surrounds are mounted on the side walls on brackets, experiment with the direction they aim in. You may obtain good results from pointing them at the ceiling (Apex 10 only) or toward the rear corners of the room, for example.

Surround speaker placement ideal for home theatre may not necessarily be perfect for multichannel music listening, where a precisely focused rear soundstage is optimal. If both types of listening are important to you, then we recommend positioning your surround speakers as a compromise between the two.



# OPTIMUM POSITIONING

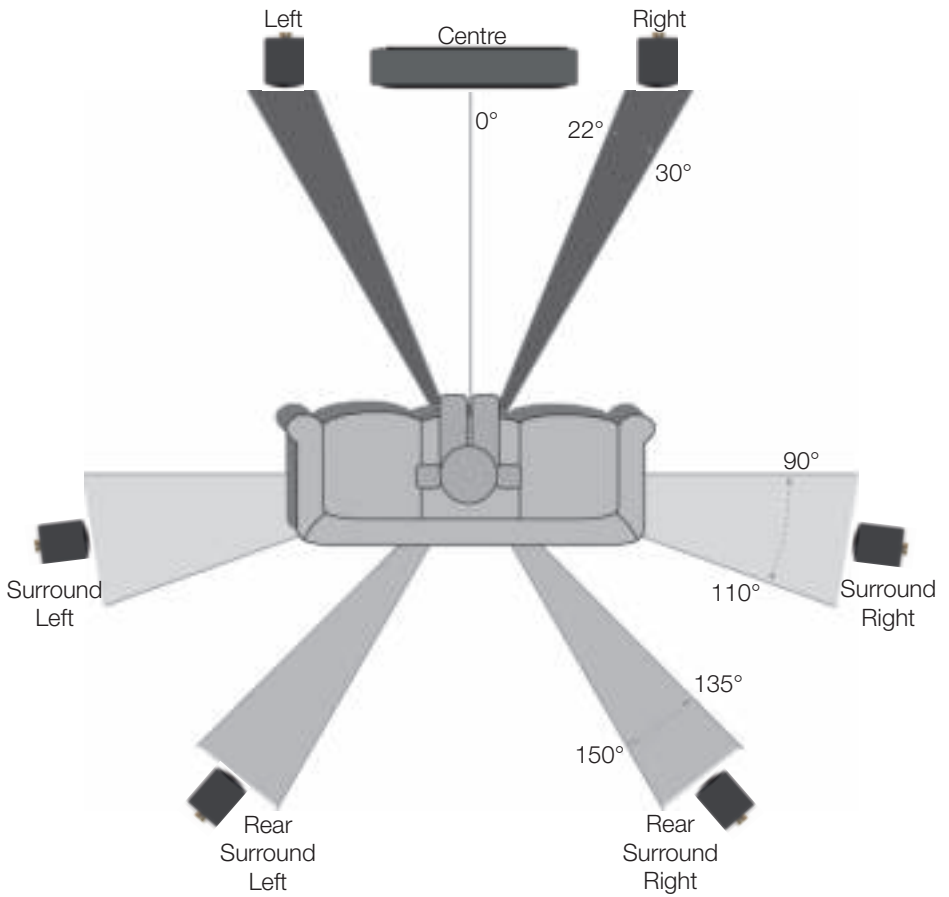

# FITTING THE APEX 10 TO A WALL/ CEILING

To fix the Apex 10 to a wall or ceiling, follow the step by step instructions below. The Apex 10 can be wall mounted horizontally (for use as a centre channel), the template just needs to be rotated.

- We do not supply fixing screws or wall plugs with these products so please purchase these separately choosing appropriate length screws (40mm (1 3/4") minimum) and the correct plugs for the wall/ ceiling the loudspeaker will be fixed to.
- After the location for the Apex 10(s) has been decided, use the supplied template to mark the fixing points and cable hole. Ensure there are no electrical cables or gas/ water pipes behind the proposed location.
- With the holes marked, proceed to drill them using the correct size drill bit for the wall plugs.
- Assemble the wall plate and components. For ceiling mounting, assemble the wall plate, bracket extension pole and pivot together using the long bolts. For wall mounting, the extension pole is not required and the shorter bolts should be used. Refer to the configurations on pages 9 & 10.
- Depending on the desired angle to aim the Apex 10, it might be necessary to change the side the clamp screw is located on. In this case, loosen the screw and flip the clamp arms over so the clamp screw is on the opposite side.
- Fix the wall plate to the wall/ ceiling and press the rubber pad (with through hole) into place.
- Connect the Apex cables to the terminals on the speaker and align the clamp arms on the cabinet with the pivot on the assembled wall plate.
- Align the speaker to the direction it will be pointing and tighten the clamp screw.
- Take a step back to ensure it is correctly aligned. If not, loosen the clamp screw slightly and adjust the angle and repeat the above step.



**DO NOT** try to adjust the angle of the speaker with the clamp screw tightened. **THIS MAY CAUSE DAMAGE AND INVALIDATE YOUR WARRANTY.**

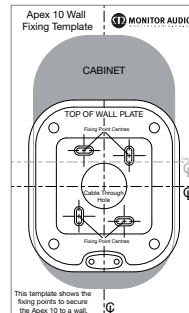
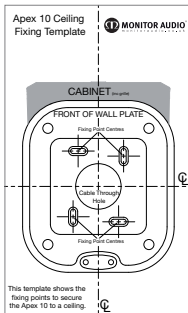

# APEX 10 FIXING CONFIGURATIONS

## Wall Mounting - Exploded

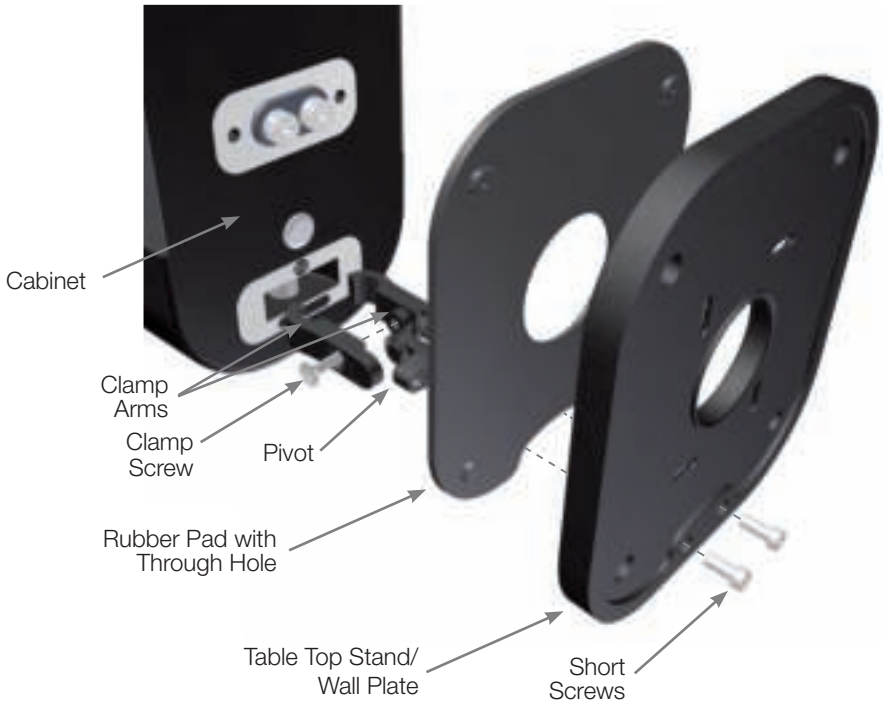

## Wall Mounting - Fixed



## Ceiling Mounting - Exploded

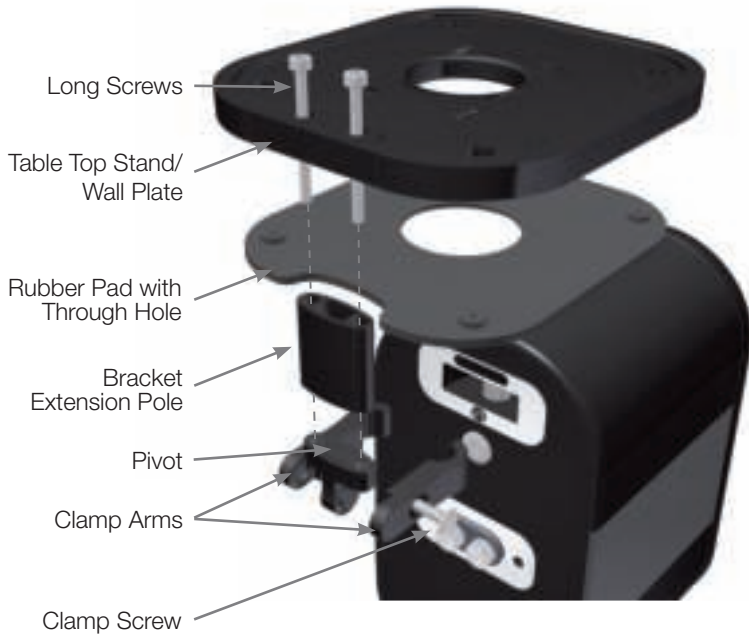

## Ceiling Mounting - Fixed



## Table Mounting - Exploded

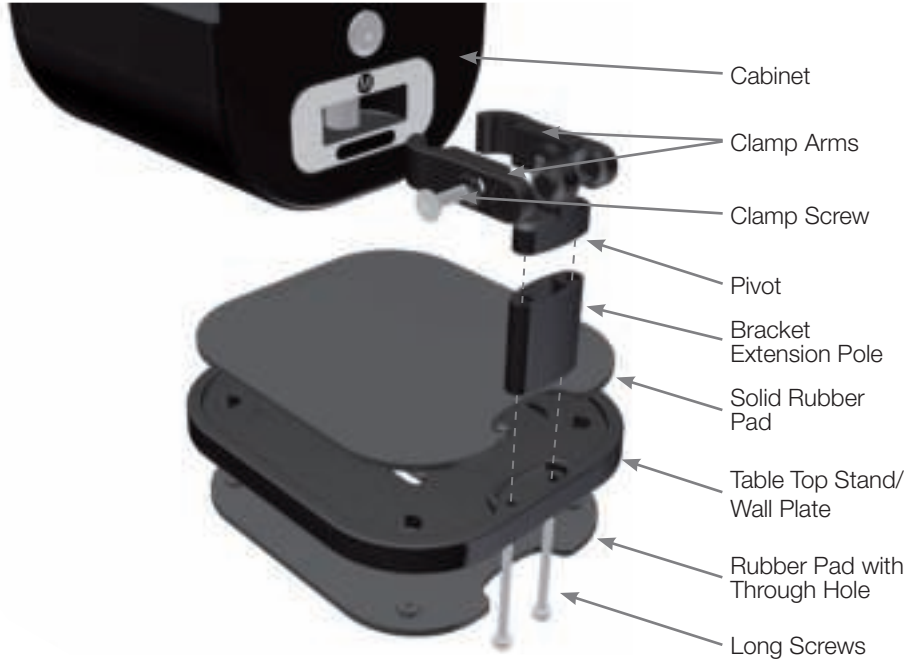

## Table Mounting - Assembled



## Apex 10 Horizontally on a Table/ Shelf - Exploded

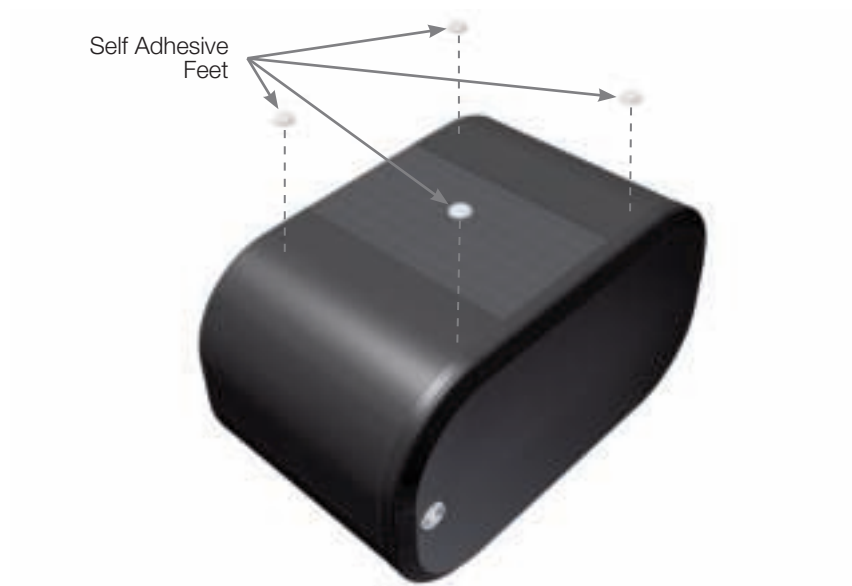

## Adhesive Feet Fixed

(Cabinet needs to be rotated for use)

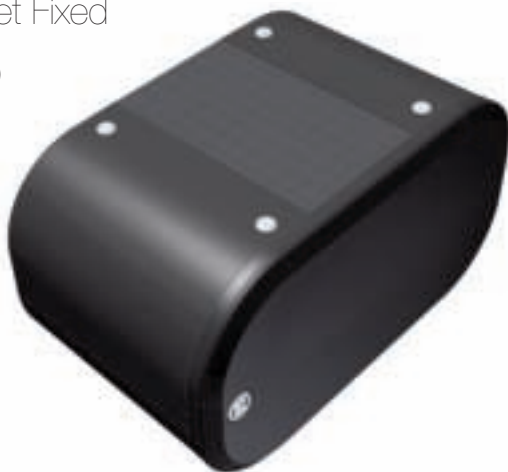

If using the Apex 10 horizontally on a table or shelf, attached the self adhesive feet as shown above to prevent movement. The badge can also be rotated.

## ADJUSTING THE APEX 10 BRACKET ASSEMBLY

The clamping mechanism can be adjusted horizontally and vertically. This is achieved by taking the weight of the cabinet and loosening the clamp screw (Hex Key included). The cabinet can now be adjusted at both pivot points 1 and 2 (as shown in the illustration below). When satisfied with the positioning, tighten the screw.



DO NOT try to adjust the angle of the speaker with the clamp screw tightened. THIS MAY CAUSE DAMAGE AND INVALIDATE YOUR WARRANTY.

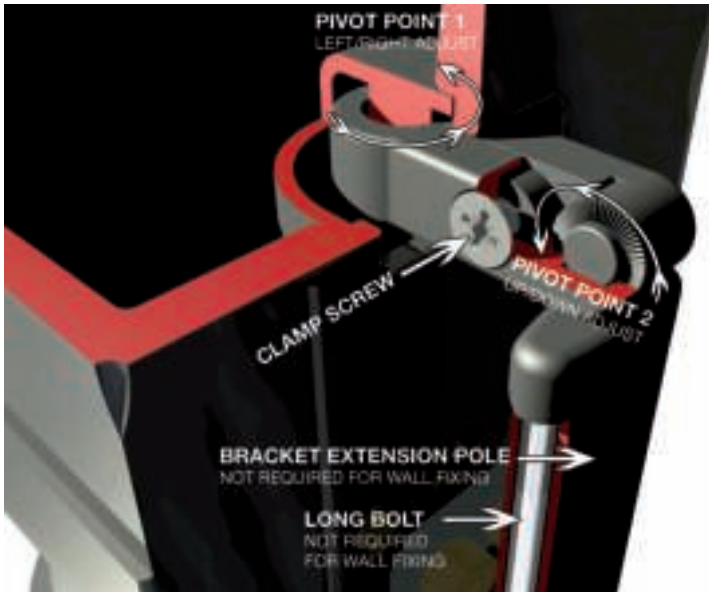

## FITTING THE APEX 40 TO A WALL

To fix the Apex 40 to a wall (horizontally or vertically), follow the step by step instructions below:

- We do not supply fixing screws or wall plugs with these products so please purchase these separately choosing appropriate length screws (40mm (1 3/4") minimum) and the correct plugs for the wall/ ceiling your loudspeaker will be fixed to.
- When the location of the Apex 40(s) has been decided, use the supplied template to mark the fixing points and cable hole. The Apex 40 can be secured using just 2 fixings, but additional fixing points are incorporated if required. Ensure there are no electrical cables or gas/ water pipes behind the proposed locations.
- With the holes marked, proceed to drill them using the correct size drill bit for the wall plugs being used.
- Remove the bracket from the cabinet by loosening the grub screws at each end of the cabinet.
- Fix the bracket to the wall.
- Connect the cables to the terminals on the speaker and align the ends of the bracket with the apertures in the rear of the cabinet.
- If the cabinet is to be angled slightly, do not push the cabinet fully onto the bracket. This allows for some angular adjustment. Tighten the grub screw to take the weight of the cabinet, and take a step back to check the alignment. If correctly aligned, check the grub screw is secure and press the rubber grub screw covers into place. If further adjustment is required, loosen the grub screw slightly, adjust and re-tighten until the correct position is found. Refer to figures 2 & 3 opposite.
- If the Apex 40 is to be used pointing directly ahead, push the cabinet fully onto the bracket and tighten the grub screw. Refer to figures 4 & 5 opposite.
- If the Apex 40 is to be used with the grille on, the badge can be added to either of the locations depending on orientation. An illustration of this can be seen on page 16.



DO NOT try to adjust the angle of the speaker with the grub screw tightened. THIS MAY CAUSE DAMAGE AND INVALIDATE YOUR WARRANTY.

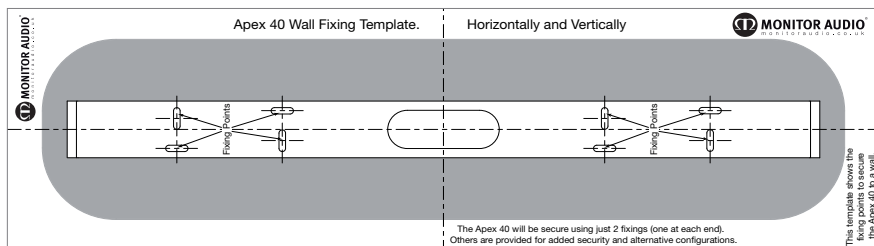



# APEX 40 FIXING CONFIGURATIONS

## Wall Mounting - Exploded

**Fig. 1**

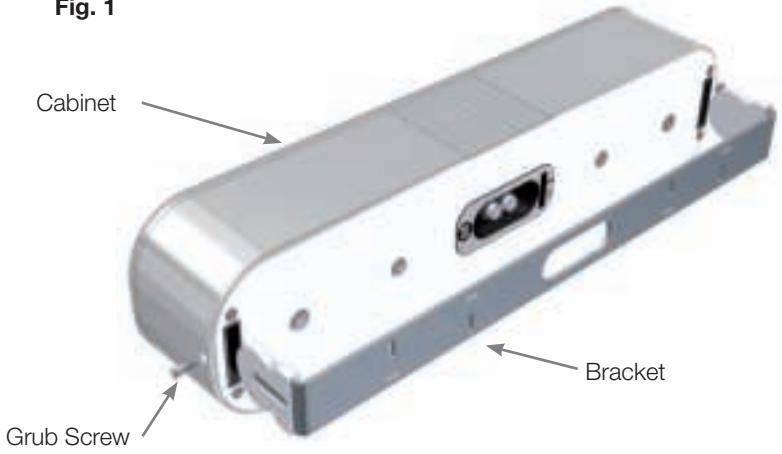

**Fig. 2**



**Fig. 3**



**Fig. 4**

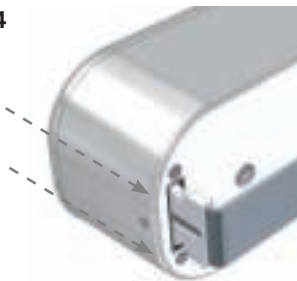

**Fig. 5**



## GRILLE BADGE FIXING

(Apex 40 only)

The Apex grille is not supplied with the badge attached. There are two potential positions for the badge depending on orientation, therefore the decision is left to the end user by providing the badge loose.

If the cabinet will be positioned vertically, use the badge location on the narrow edge of the grille (illustrated below). Press the badge through the cloth and attach the rubber grip onto the back of the spike.

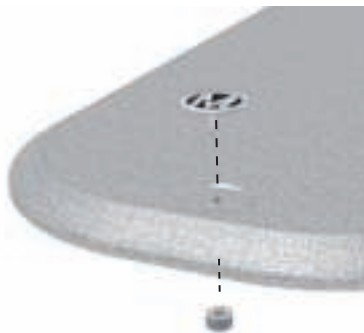

If the cabinet will be positioned horizontally, use the badge location on the broader edge of the grille (illustrated below). Press the badge through the cloth and attach the rubber grip onto the back of the spike.

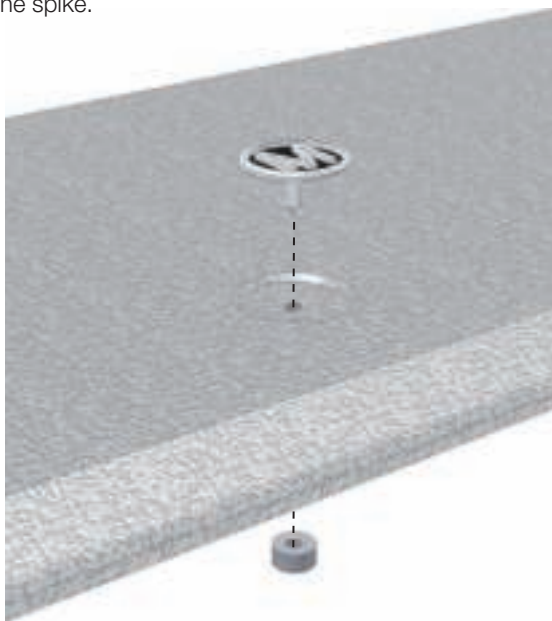

# SPECIFICATIONS

<b>Model</b>	<b>Apex 10</b>	<b>Apex 40</b>
<b>Frequency Response</b>	60Hz – 35kHz	50Hz – 35kHz
<b>Sensitivity (1W@1M)</b>	87dB	90dB
<b>Nominal Impedance</b>	8 Ohms	8 Ohms
<b>Power Handling Single (RMS)</b>	100W	200W
<b>Recommended Amp Requirements</b>	25-100 W	50-200 W
<b>Maximum SPL (dBA)</b>	110.8	116.8
<b>Bass Alignment</b>	Bass Reflex - Single, Front Mounted HiVe Port	Bass reflex – Twin, Front Mounted HiVe Port
<b>Drive Unit Complement</b>	1 x 5 1/2" C-CAM cone mid-bass driver with RST Technology. 1 x 25mm C-CAM gold dome tweeter	2 x 5 1/2" C-CAM cone mid-bass drivers with RST Technology. 1 x 25mm C-CAM gold dome tweeter
<b>Crossover Frequency</b>	3kHz	600Hz & 3kHz
<b>External Dimensions. mm (H x W x D)</b>	250 x 140 x 140	610 x 140 x 100
<b>External Dimensions. Inch (H x W x D)</b>	9 13/16 x 5 1/2 x 5 1/2	24 x 5 1/2 x 3 15/16
<b>Weight (each) Kg ( lb)</b>	3.95 (8 3/4)	6.85 (15 1/8)

## GUARANTEE AND SERVICE

To validate your warranty please visit [www.monitoraudio.co.uk](http://www.monitoraudio.co.uk) within 30 days of purchase.

This equipment has been fully tested prior to dispatch from the factory. Both the craftsmanship and the performance of this product is guaranteed against manufacturing defects for the period of **five** years from the date of purchase (see conditions below), provided that the product was supplied by an authorised Monitor Audio retailer under the consumer sale agreement. (The words 'consumer sale' shall be construed in accordance with section 15 of the supply of goods act 1973). Monitor Audio accepts no responsibility for defects arising from accident, misuse, abuse, wear and tear, modification or operation outside of that specified within this instruction manual. Neither will responsibility be accepted for damage or loss occurring during transit to or from the parties claiming under this guarantee.

This guarantee covers both labour and parts. The liability of Monitor Audio is limited to the cost of repair or replacement of the defective parts (at the discretion of Monitor Audio) and under no circumstances extends to consequential losses or damage.

## CLAIMS UNDER THIS GUARANTEE

The equipment should be returned in its original packaging to the original supplier where possible, or to any other authorised Monitor Audio dealer. If it is not possible to return the equipment by hand, then it should be sent carriage prepaid via a reputable carrier. If the original packing is not available replacement packaging can be purchased from Monitor Audio. If you have any difficulties complying with these requirements please contact us at the following address:

Customer Service  
Monitor Audio Ltd.  
Unit 2, 24 Brook Road  
Rayleigh  
Essex  
SS6 7XJ  
England

Tel: 44 (0) 1268 740580  
Fax: 44 (0) 1268 740589  
Internet: [www.monitoraudio.co.uk](http://www.monitoraudio.co.uk)  
Email: [info@monitoraudio.co.uk](mailto:info@monitoraudio.co.uk)

This guarantee does not affect the statutory rights of the consumer under UK law.

# EC DECLARATION OF CONFORMITY

EC Declaration of Conformity

We, Monitor Audio Ltd.  
Unit 2,24 Brook Road  
Rayleigh  
Essex  
SS6 7XJ  
England



Declare in own responsibility, that the Apex Series product described in this manual is in compliance with Technical Standards/Council Directives:

**(LVD) 73/23/EEC Low Voltage Directive**

EN60065: 09.93+ A11:09.97 Safety requirements for mains operated electronic and related apparatus for household and similar use.

**(EMC) 89/336/EEC Electro Magnetic Compatibility**

EN55013: 08.90+A12:08.94+A13:12.96 Limits and methods of measurement of radio disturbance characteristics of broadcast receivers and associated equipment.

EN55020: 12.94+A11:12.96 Electro magnetic immunity of broadcast receivers and associated equipment.

EN61000-3-2: 04.95+A1:1998+A2:1998 Electro magnetic compatibility (EMC) – Part 3: Limits – Section 2: Limits for harmonic current emissions (equipment input current up to and including 16 Ampere per phase).

EN6100-3-3: 01.95 Electro magnetic compatibility (EMC) – Part 3: Limits – Section 3 : Limits of voltage fluctuations and flicker in low-voltage supply systems for equipment with rated current up and including 16 Ampere per phase.

Signed by:

A handwritten signature in blue ink, appearing to read 'D.S. Hartley'.

Name: D.S. Hartley

Position: Technical Director

Company: Monitor Audio Ltd

## DATA PROTECTION

We at Monitor Audio are committed to respecting the wishes and privacy of our customers. Any information you provide will be held in the strictest confidence and only used within the Monitor Audio organisation for the provision of services such as warranty claims or spare parts.

We may wish to contact you in the future to ensure you are happy with the products and standards of service we provide and to keep you up-to-date with the latest products and promotions we have to offer.

Should you wish not to be contacted by us either by post, e-mail or phone, please tick the box on the warranty card. Alternatively you can request not to be contacted in future by writing to Customer Service, at the address on the previous page.

## OWNER INFORMATION

### **Product Details**

Model .....

Product Serial No .....

Date of Purchase .....

### **Dealer Details**

Dealer Name .....

Address .....

.....

e-mail address .....

Monitor Audio reserves the right to alter specifications without notice.





Monitor Audio Ltd.  
Unit 2, 24 Brook Road  
Rayleigh, Essex  
SS6 7XJ  
England  
Tel: 01268 740580  
Fax: 01268 740589  
Email: [info@monitoraudio.co.uk](mailto:info@monitoraudio.co.uk)

[monitoraudio.co.uk](http://monitoraudio.co.uk)  
Designed in the United Kingdom

Version 2