

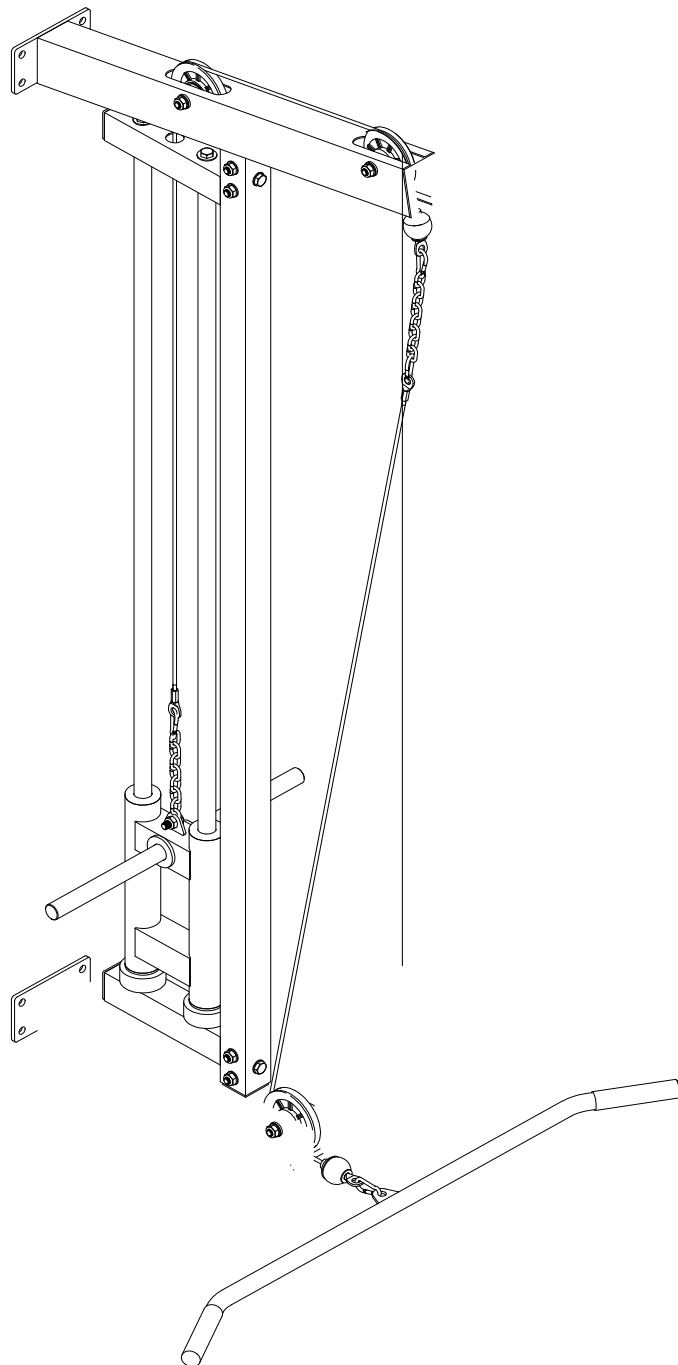

WALL MOUNTED LAT STATION



Page 2 Table of content

Page 3 - 4 Safety Instructions

Page 5 Technical data overview

Page 6 Parts list

Page 7-10 Assembling steps

Page 11 Cleaning/Maintenance/Disposal

Page 12 Warranty

Page 13-14 Training information

Page 15 Warm-Up/Stretching

Page 16-17 Notes

General information

Please ensure that all persons using the device have read and understood the assembly and operating instructions. The assembly and operating instructions must be regarded as part of the product and kept in a safe place so that they can be referred to at any time if necessary. Ensure that the safety and maintenance instructions are followed exactly. Any use that deviates from these instructions may result in damage to health, accidents or damage to the device, for which the manufacturer and distributor cannot accept any liability.

Personal safety

Before starting to use the device, you should consult your family doctor to determine whether the training is suitable for you from a health point of view. This applies especially to people who have a hereditary predisposition to high blood pressure or heart disease, smoke, have high cholesterol levels, are overweight and/or have not exercised regularly in the last year. If you are on medication that affects your heart rate, medical advice is absolutely essential. Please also note that excessive exercise can seriously jeopardize your health. If you experience any signs of weakness, nausea, dizziness, pain, shortness of breath or other abnormal symptoms during training, please stop training immediately and consult a doctor in case of emergency.

As a general rule, sports equipment is not a toy. Unless otherwise described, the equipment may only be used by one person at a time for training. It may therefore only be used as intended and by appropriately informed and instructed persons. Persons such as children, invalids, physically and mentally impaired persons should only use the device in the presence of another person who can provide assistance and guidance. Suitable measures should be taken to prevent unsupervised children from using the device. It must be ensured that the user and other persons never move or stand with any parts of their body in the area of moving parts.

Training clothes and shoes suitable for fitness training with the device must be worn. The clothing must be such that it cannot get caught in the device during training due to its shape (e.g. length). The training shoes should be chosen to match the training equipment, basically give the foot a firm grip and have a non-slip sole.

Assembly

Check that all parts and tools listed in the parts list are present. Please keep in mind that some parts may be pre-assembled. Keep children and animals away from the assembly area during assembly. Tools, packaging materials (e.g. foil) or small parts may pose a risk of injury or suffocation. Also make sure that you have enough space to move around during assembly. Before using the device for the first time and at regular intervals, check the tightness of all screws, nuts and other connections to ensure the safe operating condition of the device.

Location

Set up the device in a flat, stable and dry place. Uneven surfaces can be compensated by adjustable parts of the device, if available. To protect sensitive surfaces against pressure marks and dirt, we recommend placing a floor protection mat underneath. Please also remove all objects within the required training radius before starting training. Use outdoors or in rooms with increased humidity is not permitted.

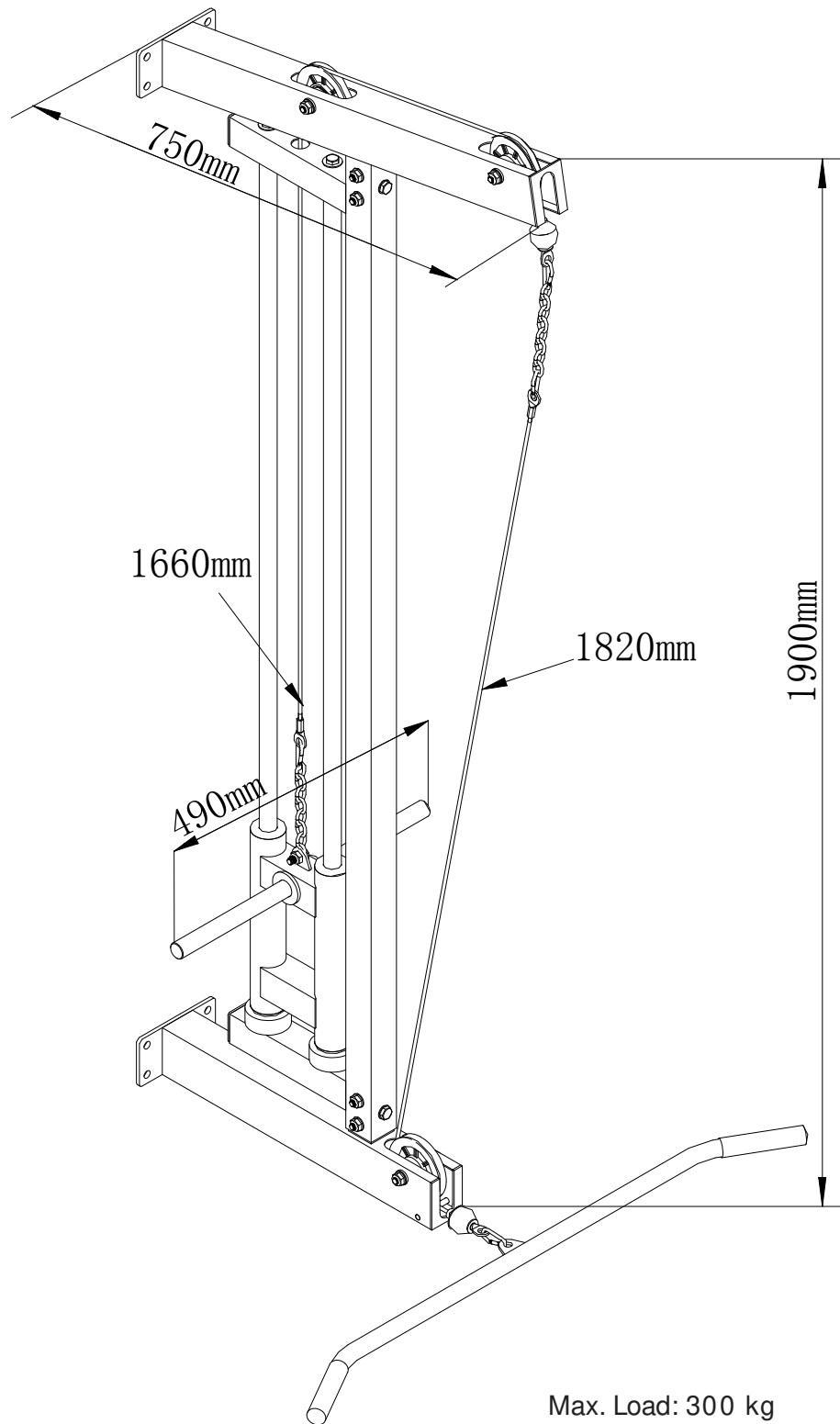

Washer: ($\phi 10$)

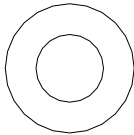

18X

Big Washer: ($\phi 10$)

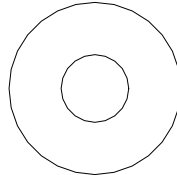

2X

Lock Nut: (M10)

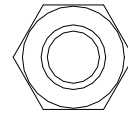

8X

Hex Bolt: (M10*20)

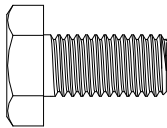

7X

Hex Bolt: (M10*80)

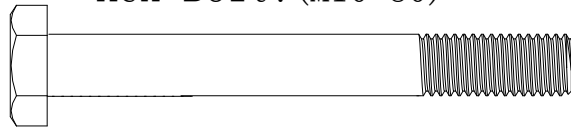

3X

Hex Bolt: (M10*30)

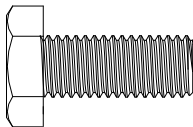

1X

Hex Bolt: (M10*65)

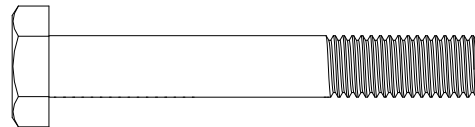

4X

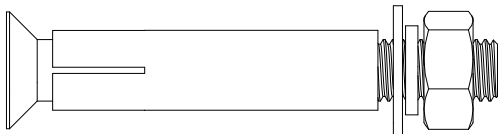

Expansion Bolt: (M10*80)

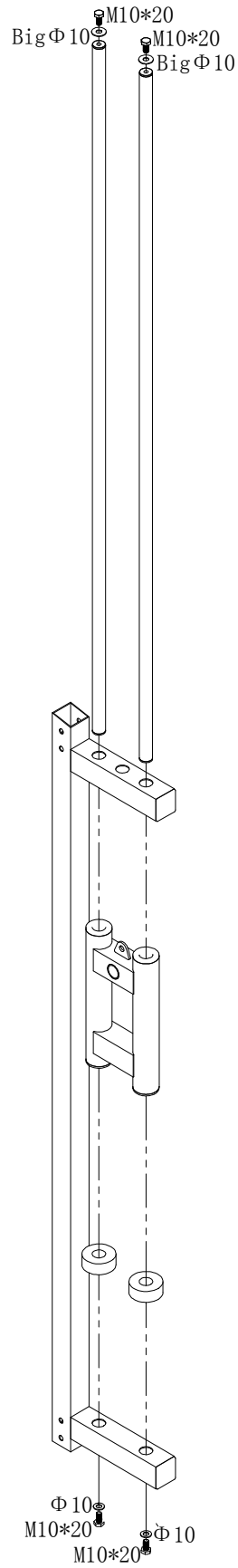

8X

1.



		
Washer (Φ 10) - 2PCS	Big Washer (Φ 10) - 2PCS	Hex Bolt (M10*20) - 4PCS

2.

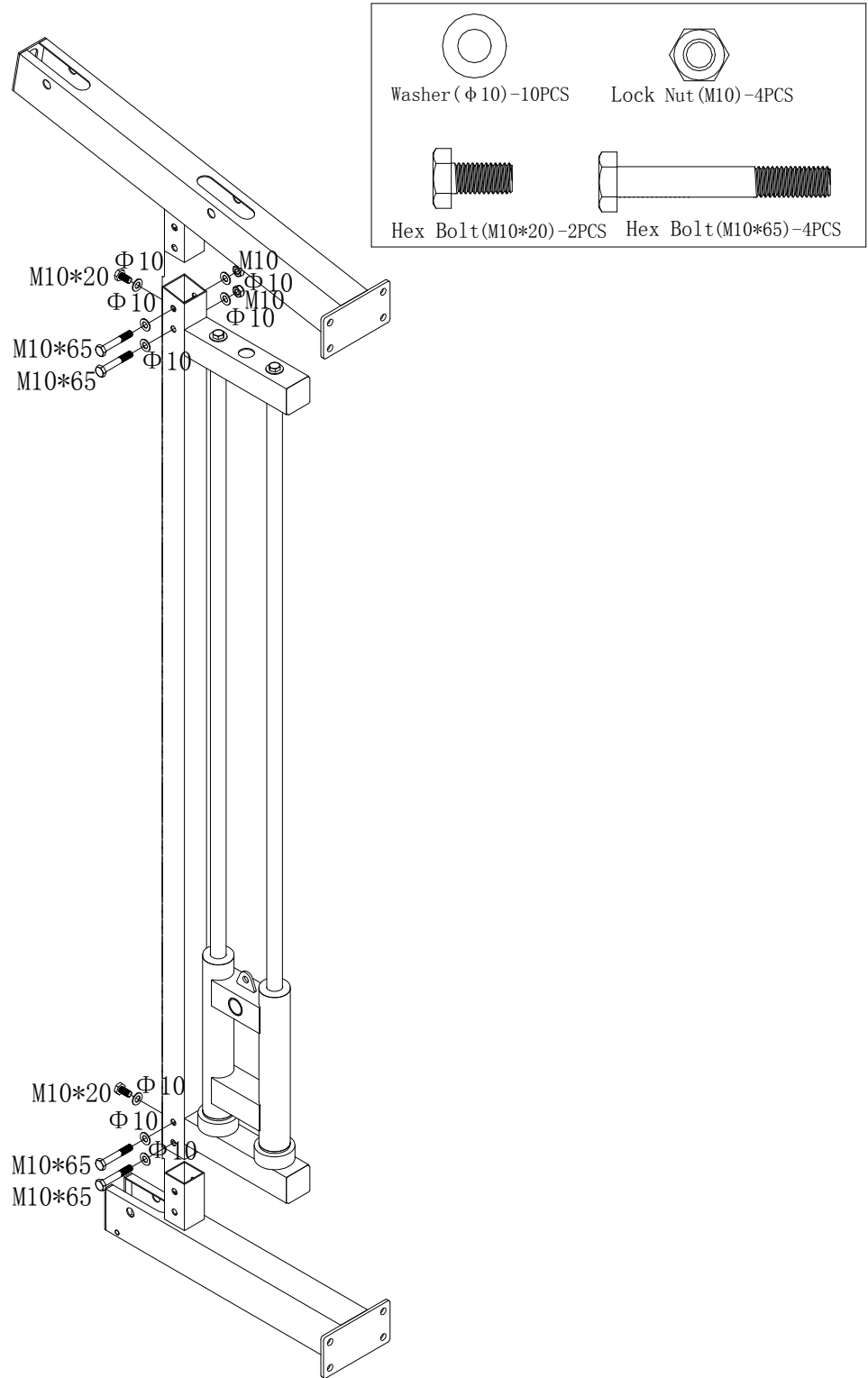

3.

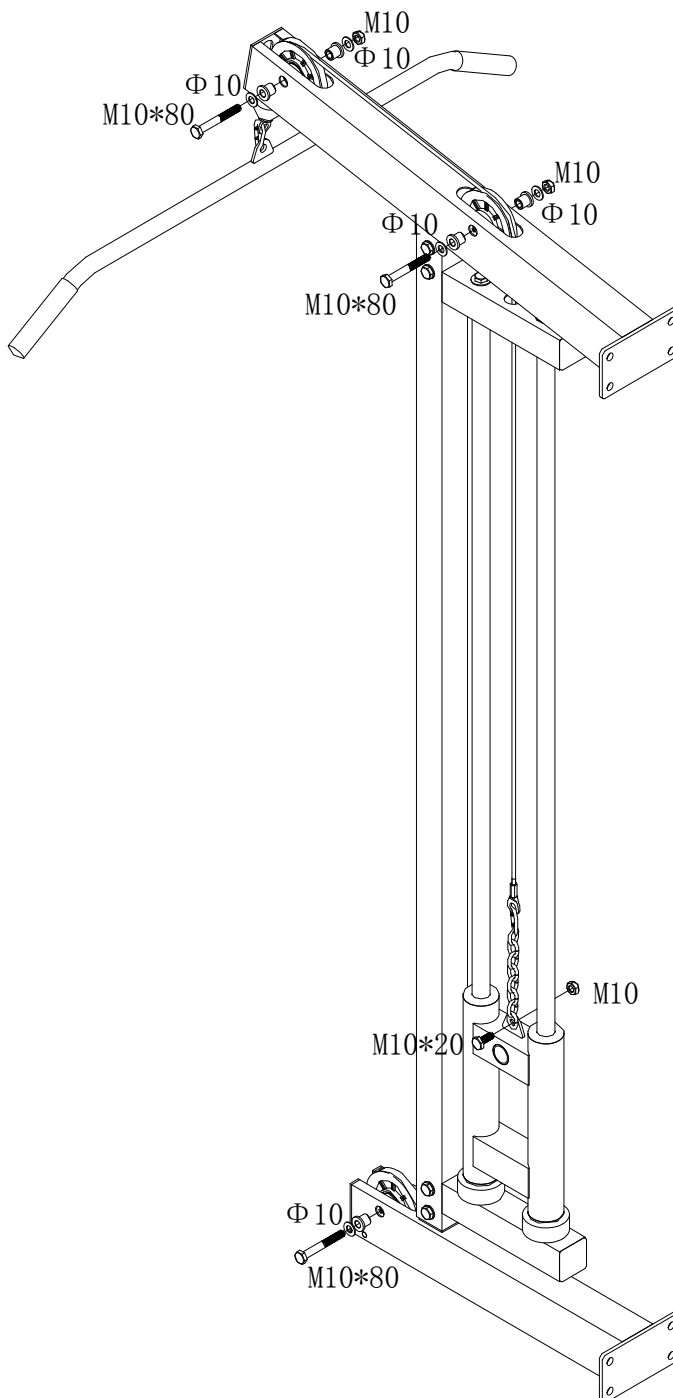
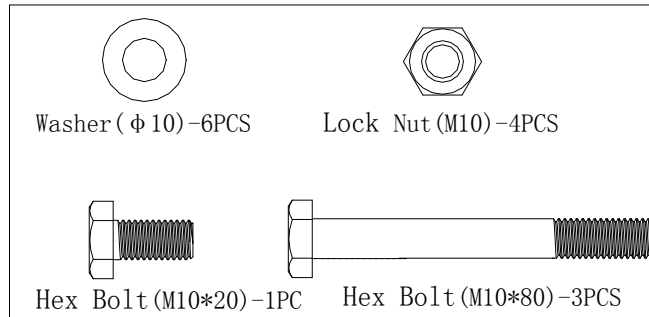

4.

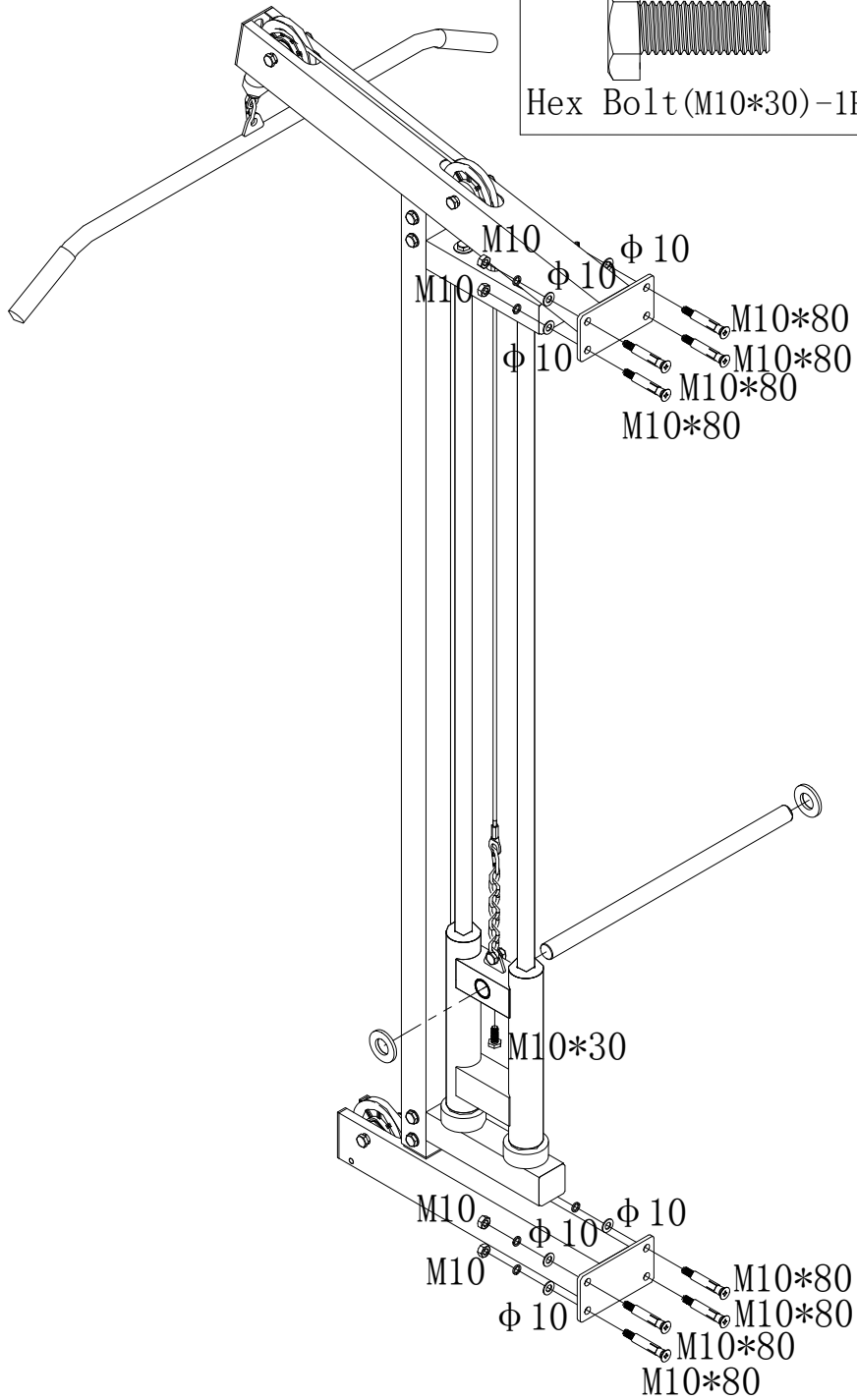
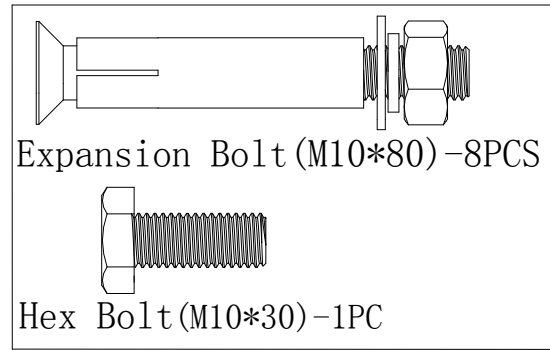

Cleaning

Please use only a slightly damp cloth for cleaning. Attention! Never use gasoline, thinner or other aggressive cleaning products to clean the surface, as this may cause damage. The device is only suitable for private home and for indoor use. Keep the device clean and moisture away from the device. Damage caused by body sweat or other liquids is not covered by the warranty under any circumstances.

Maintenance

We recommend checking the screws and moving parts at regular intervals. The device may only be used for training if it is working properly. For possible repairs or needed spare parts, please contact our customer service. **WARNING:** The device may only be used after it has been successfully repaired.

Disposal

In the interest of the environment, do not dispose of the packaging materials, empty batteries and parts of the device with the household waste, but throw them into the designated collection containers or hand them in at suitable collection points. Observe the currently valid regulations.

The warranty is 24 months, applies to new goods at first purchase and begins with the invoice or delivery date. During the warranty period, any defects will be repaired free of charge. If you find a defect, you are obliged to report it immediately to the seller. It is at the discretion of the seller to fulfill the warranty by sending spare parts or replacement. In case of shipment of spare parts, the seller has the right to replace without loss of warranty. Repair at the place of installation is excluded. Devices for home use are not suitable for commercial or industrial use. Violation in the use will result in warranty reduction or loss. Warranty coverage applies only to defects in materials or workmanship. Wear parts or damage caused by misuse or improper handling, use of force and interventions made without prior consultation with our service department will void the warranty. If possible, please keep the original packaging for the duration of the warranty period in order to adequately protect the goods in the event of a return and do not send any goods carriage forward to our address. A claim under warranty does not result in an extension of the warranty period. Claims for compensation for damage that may occur outside the device (unless liability is mandatory regulated by law) are excluded.

Manufacturer:

Gorilla Sports GmbH
Nordring 80
64521 Groß-Gerau

Here you can find an overview of our international partners:
www.gorillasports.eu

Training preparations

Before you start training, not only must the training equipment be in perfect condition, but you or your body should also be ready for training. Therefore, if you have not done any strength/endurance training for a long time, you should always consult your family doctor before starting your training and carry out a fitness check-up. Please also discuss your training goals with your doctor; he or she can certainly give you valuable tips and information. In particular, this applies to people over 35 years of age, people who are overweight and/or have problems with the cardiovascular system.

Workout planning

The be-all and end-all for effective, goal-oriented, but also motivating training is planning your workouts. Therefore, plan your fitness training into your normal daily routine as a fixed component. Unplanned training can quickly become a disruptive factor, or be postponed indefinitely for another task. Plan your workout for the long term, for months at a time, and not just from day to day or week to week. Training planning also includes providing sufficient motivation during the workout. Music is ideal for this. Also provide training rewards. Set realistic goals, such as losing 1 kg in four weeks, increasing your training weight by 10 kg in six weeks, or similar. When your goals are achieved, reward yourself!

Training frequency

Experts recommend doing endurance/strength training 3 to 4 days a week. Certainly, the more often you train, the faster you will reach your training goal. However, when planning your workout, make sure to take sufficient breaks from training to give your body enough time to recover and regenerate. You should take at least one day off after each training session.

Hydration

Sufficient fluid intake is essential before and during training. During a training session of 60 minutes, it is quite possible to lose up to 0.5 liters of fluid. To compensate for this fluid loss, apple spritzer in a mixing ratio of one-third apple juice and two-thirds mineral water is ideal, as it contains and replaces all the electrolytes and minerals that the body loses through sweat. 30 minutes before the start of your training session you should drink about 330 ml. Ensure a balanced fluid intake during your workout.

Warm-Up

Complete a warm-up before each training session. Warm up your body by 5 - 7 minutes before the actual training session at low load with skipping rope, cross trainer or similar. This is the best way to prepare yourself for the upcoming workout.

Cool-Down

Never stop training immediately after finishing your actual training program. Let your training, similar to the warm-up phase still 5 - 7 minutes at low load on an exercise bike, cross trainer, etc. loosely run out. Afterwards, you should always stretch your muscles well.

Thighs



Support yourself with your right hand against a wall or your exercise equipment. Lift the left foot backward and hold it with the left hand. The knee points straight down. Now pull your thigh back until you feel a slight stretch in the muscle. Hold this position for 15 - 20 seconds. Slowly release your foot and slowly put the leg down again. Now repeat this exercise with the right leg.

Legs and lower back



Sit on the floor with your legs stretched out. Try to grasp the tops of your feet with both hands, stretching your arms and bending your upper body slightly forward. Hold this position for 15 to 20 seconds. Release the tops of your feet and slowly and steadily straighten your upper body.

Triceps and shoulder



Reach behind your head to your right shoulder with your left hand and pull on your left elbow with your right hand until you feel a slight tug. Hold this position for 15-20 seconds. Now repeat this exercise with the right hand.

Upper body

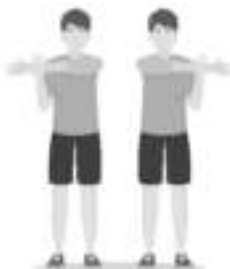

Bring your extended left arm past your right arm at shoulder level and pull on your left upper arm with your right hand until you feel a slight tug. Hold this position for 15-20 seconds. Now repeat this exercise with your right hand.

GORILLA **SPORTS**

NORDRING 80, 64521 GROß-GERAU
WWW.GORILLASPORTS.EU