

# DIANA

---

## OVAL POOLS

---

## ASSEMBLY INSTRUCTIONS

---

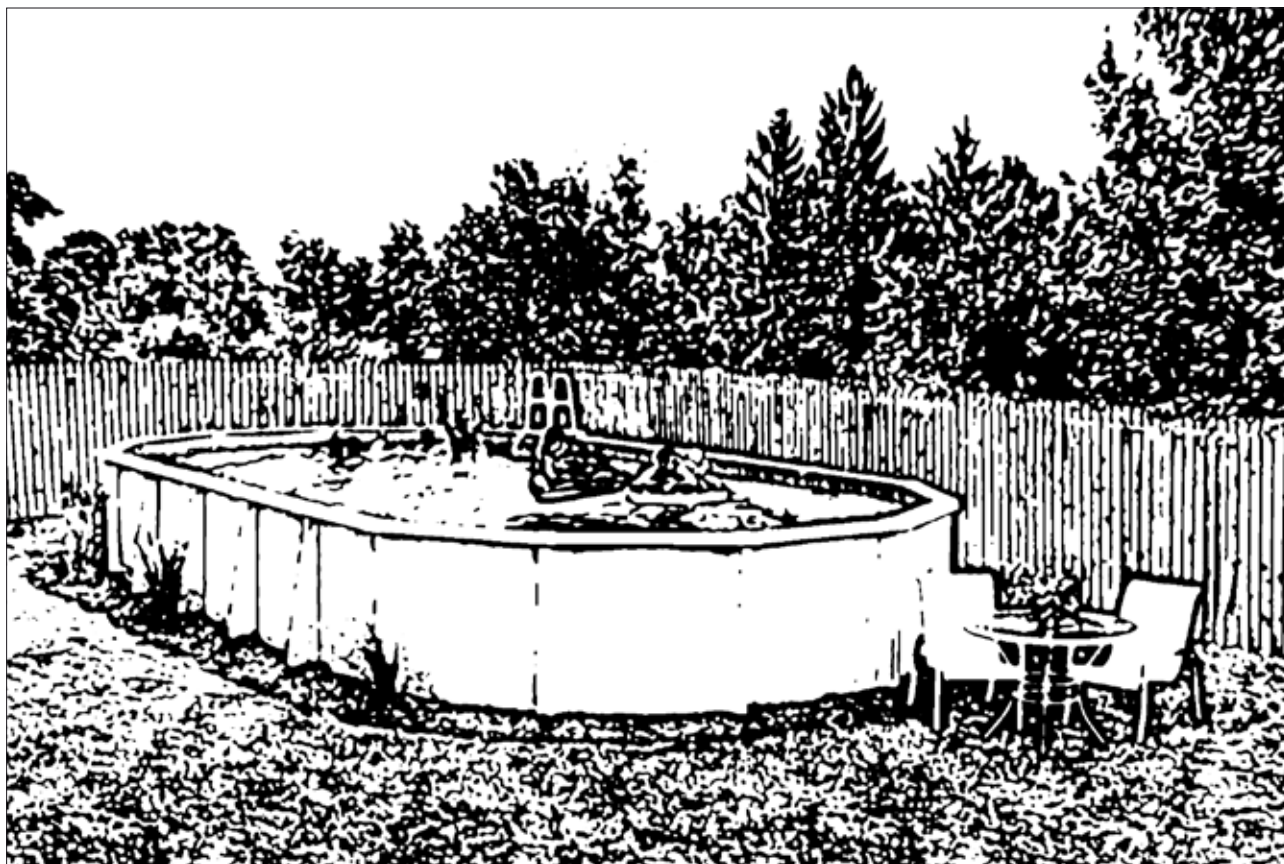

## Installation Instructions

### HOW TO USE THESE INSTRUCTIONS

Be sure to read these instructions completely before beginning the installation of your pool. **ATTENTION:** Always use these assembly instructions to install your swimming pool. Ignore any English instructions included with the pool, as the size will be in inches, etc. **ATTENTION:** Check the pool parts with the English parts lists.

These are installation instructions for the installation of several sizes of round pools. Use the pool parts list and extensive illustrations to identify your pool parts; then read these instructions and follow the steps that pertain to your pool assembly.

Doughboy cannot be held liable for damage caused by careless or improper installation. Your warranty is void if the pool assembly and installation instructions are not followed exactly, or if the pool design is altered in any way.

#### Contracted Installation

Doughboy is not affiliated with any professional pool installers and cannot assume any responsibility for installation mistakes made by the homeowner. If the pool is installed by others, please supervise the installation and make sure that the correct installation method is applied.

#### Change of pool design

Doughboy expressly reserves the right to change or modify the design and instruction during the course of our manufacturing procedures, without incurring any obligation or liability to reapply such modifications on products previously or currently sold.

### CAUTIONS

1. Do not attempt to install pool wall on windy days. An unsupported pool wall can easily blow down and may thus cause personal injury.
2. When assembling your pool, keep the parts not currently used in an area out of the way. Unpacked parts are easily tripped over and may be damaged or cause personal injury.

3. Do not attempt to lift the heavy boxes by yourself. To reduce the possibility of personal injury, have someone help you move heavy boxes (pool wall, liner, etc.).

### WARNING

1. Your pool must be level within 2-3 cm all around. An unlevel pool may cause excessive stress on the pool frame. A pool which is not level may cause a lot of pressure on the frame. This may result in pool failure which could cause serious personal injury.
2. Your pool must be on undisturbed soil, preferably filtered sand. Filled up sand, sudden slopes within 15 cm or the water runoff may cause a cave in of the subsoil. This could cause pool failure and may cause personal injury.
3. Always install the Warning Sign. The decal is designed to warn you, your friends and loved ones that your pool is to be used for swimming and wading only. Do not allow any form of horseplay in or around the pool. Failure to follow this warning can lead to severe personal injury. Read the "Safety First" booklet (in English).
4. Use stabilised sand as a pool cove. Common sand can easily erode and allow the pool liner to rupture which may cause pool failure or personal injury.
5. Secure your pool when not in use. Ladders and gates should be secured to reduce the possibility of unauthorised entry and possible serious accidents.
6. Always repair liner leaks. Continued leakage between the pool wall and liner can cause wall damage to the wall which eventually may result in pool wall failure. This could result in personal injury.
7. To reduce the risk of possible electrical shock, never install your pool under overhead wires.
8. Do not alter your pool as this may cause pool failure. Your warranty is void if the pool is altered.
9. Do not install a diving board, pool slide or any other recreational accessories for use during diving, sliding or jumping into your pool.
10. **ATTENTION:** Do not install the pool liner at temperatures under 16°C. At lower temperatures the liner's elasticity is too limited for proper installation.

### Where to position my pool?

Before you start building your pool, pay attention to the following points:

1. Garden fence.
2. Trees, roots, overhanging branches and falling leaves.
3. Underground wiring or cables.
4. Position pool with regard to sun terrace or sunken sitting area.
5. Position pool with regard to the sunshine.
6. Supervision of small children.
7. Convenient location of filter and pump.
8. Convenient electrical outlet for the pump
9. 2 or 3 people for assistance during assembly.
10. Do not build in case of strong wind.
11. Walking space around your pool (60 cm).
12. Put your pool on a level underground.
13. In case of building the pool into the ground: groundwater level.

### MATERIALS AND TOOLS NEEDED

(Not included)

#### Materials:

1. 12 nails, 4 cm long
2. Patio blocks, 1 per stud
3. Roller masonry or kite string
4. Binder clips
5. Straight board, 5 x 10 cm diameter  
(Length, please refer to Step 1)
6. Scotch tape 5 cm wide
7. Wooden stake 5 x 5 cm, 50 cm long
8. Sub-liner

#### Tools:

1. Carpenter's level
2. Carpenter's saw
3. Fibre tip pen
4. Stanley knife
5. Star + regular screwdriver
6. Hammer
7. Shovel / barrow
8. Rake
9. Tape measure

### POOL SIZES

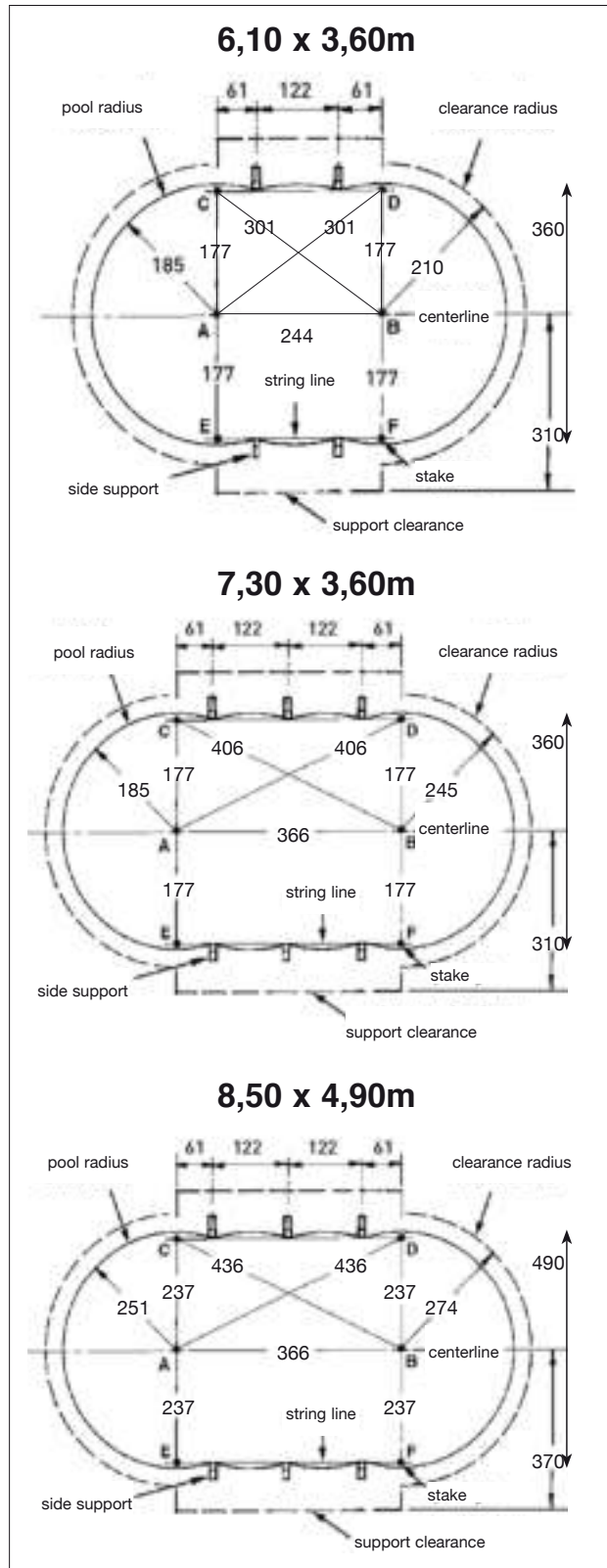

## POOL LAYOUT

### Step 1

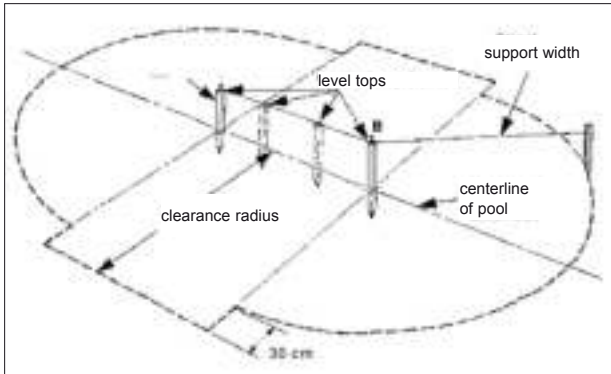

By means of the plan you determine the layout of the clearance. Locate stakes A and B (in accordance with indicated dimensions) and make from there 2 circles for the clearance.

## GROUND LEVELING

### Step 2

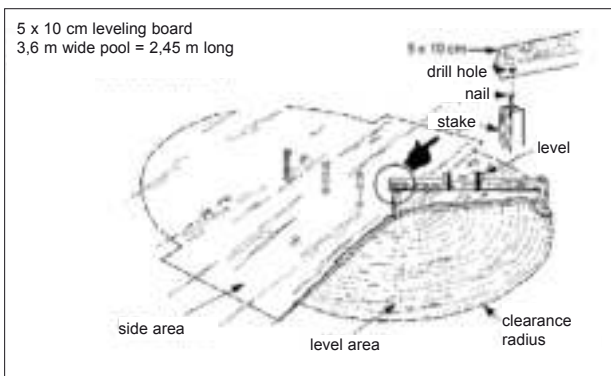

Clear and level the pool area in the clearance as indicated. For a firm ground it is better to remove high points than filling in low spots. Remove sods, stones, roots and other objects that could puncture the liner. The entire assembled pool framework must sit on flat ground.

## STAKES AND STRING LINES

### Step 3

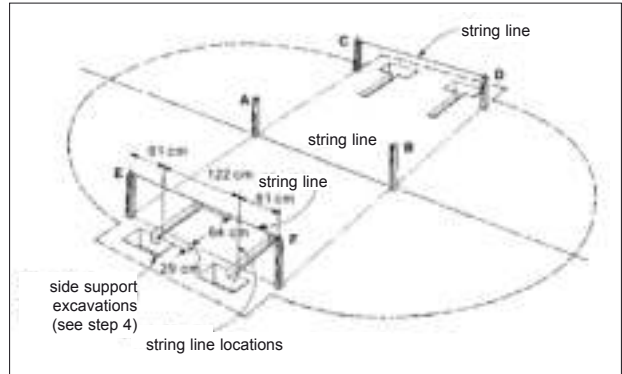

Locate 4 stakes C, D, E and F in accordance with indicated measures of the plan of your pool. Attach strings between C and D, then E and F. Now mark the assembled side supports, as indicated on the plan.

## SIDE SUPPORT EXCAVATIONS

### Step 4

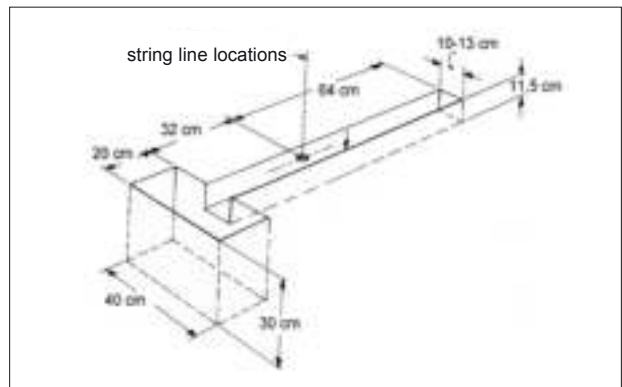

Carefully dig out side support trenches following dimensions above.

## EXPLODED SIDE SECTION

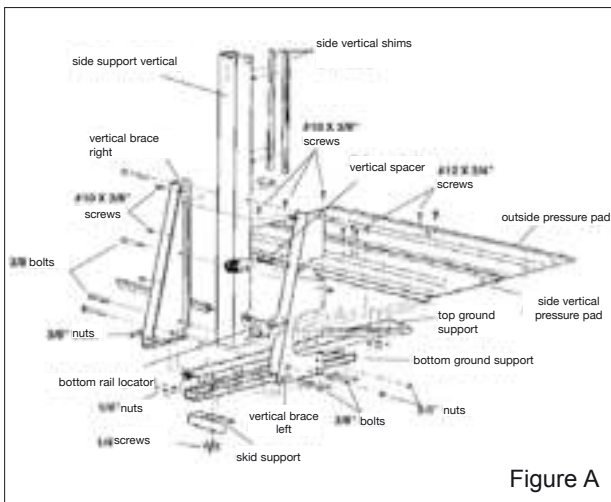
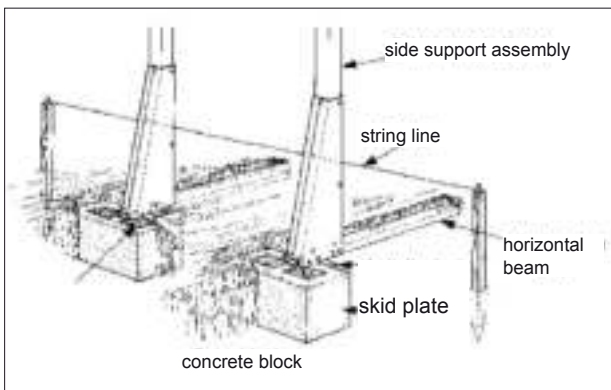

Figure A

## INSTALL CONCRETE BLOCKS

### Step 5



Place two concrete blocks into the excavations and place the assembled side supports into each trench perpendicular, so that the front side of the side support is situated to the tautly wire.

## POSITION SIDE VERTICAL SHIMS (WITHOUT PROTRUDING HORIZONTAL BEAM)

### Step 5a

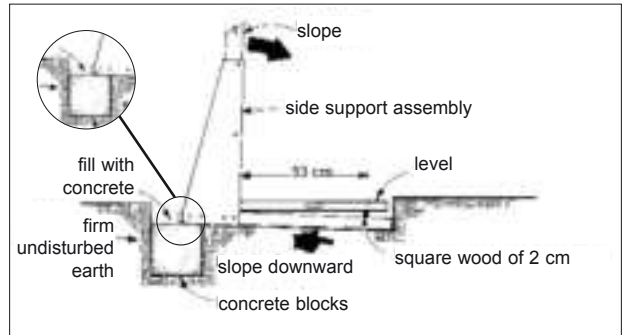

Place the horizontal beams two degrees tilted in the ground. The side supports will stand straight again by the pressure of the water.

## POSITION SIDE VERTICAL SHIMS (WITH PROTRUDING HORIZONTAL BEAM)

### Step 5b

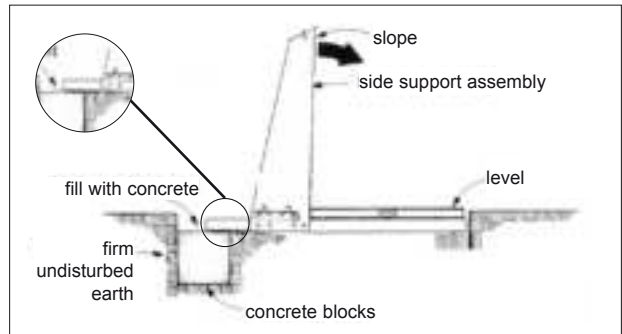

Place the horizontal beam level. The side supports will stand straight again by the pressure of the water.

## DIG OUT FOR PRESSURE PADS

### Step 6

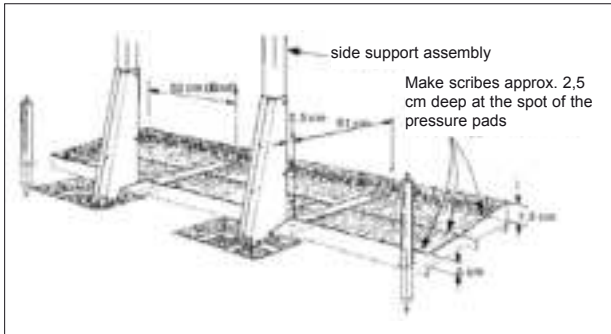

Remove dirt at the spot of the pressure pads so that the pressure pads can be assembled on the horizontal beams of the side support assemblies.

## INSTALL PRESSURE PADS

### Step 7

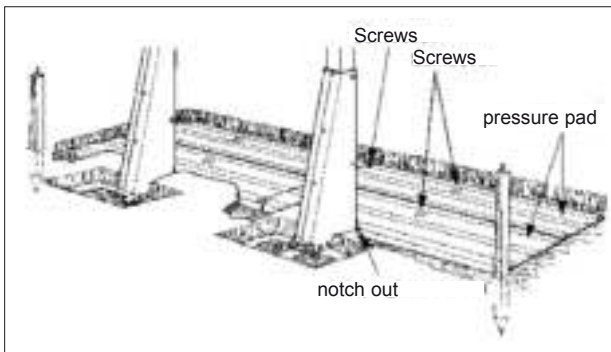

Fix the pressure pads both to each other and to the horizontal beams of the side supports and make sure everything is filled up.

## INSTALL BOTTOM RAIL LOCATOR

### Step 8

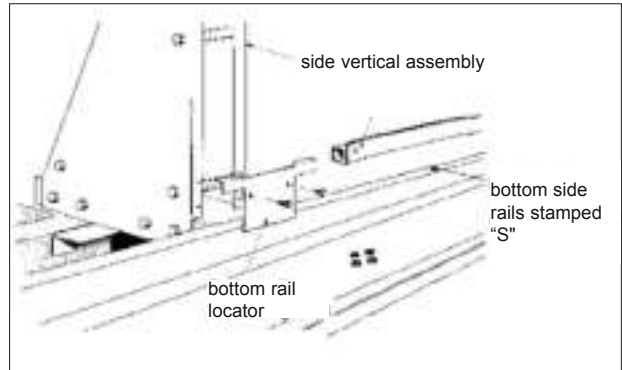

Assemble the bottom side rails stamped "S" between the side vertical assemblies, as indicated on the plan.

## INSTALL BOTTOM RAILS

### Step 9

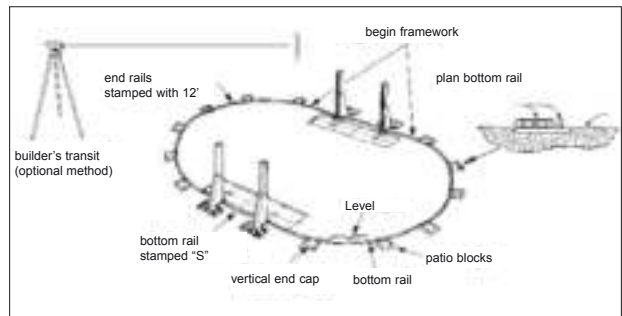

Slide the bottom rails into the vertical end caps, groove up (see plan). Start on opposite sides of the side vertical assemblies with the end rails stamped with 12". When the bottom condition is not optimal, place a patio block under every vertical end cap (sunk on bottom level for extra certainty).

## INSTALL WALL

### Step 10

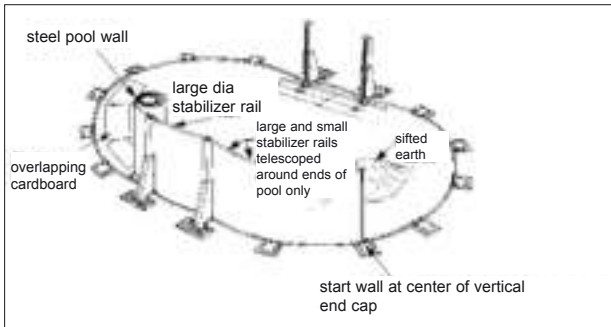

Remove steel pool wall from carton. Note 'Up' arrow on wall. Determine starting point of wall from preliminary planning, depending on the place of the pump and the filter. The skimmer opening will be at the inside end of the wall coil. Always start with the center of a vertical end cap. Always uncoil 1,5 m and insert bottom edge into groove in bottom rails. When the ends of the pool do not connect completely, correct this by telescope the bottom rail more or less into the vertical end caps.

*NOTE: Place enough sifted earth into the pool area to cover the pressure pads. With a high groundwater level (in ground pool) we advise to install a concrete floor.*

## INSTALL WALL JOINT

### Step 11

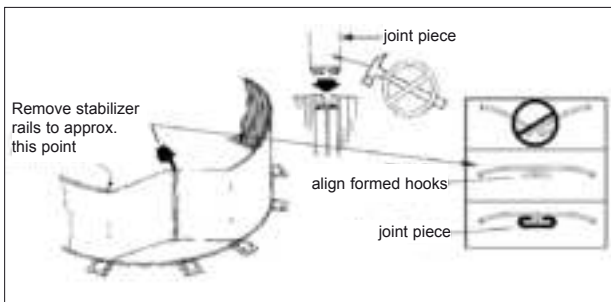

Bring wall steel ends together in center of vertical cap (see plan). This can be done without any extra effort. Use a bit of oil or grease. If joint piece does not slide on easily, correct the measures of your pool (never use a hammer).

## INSTALL VERTICALS & END CAPS

### Step 12

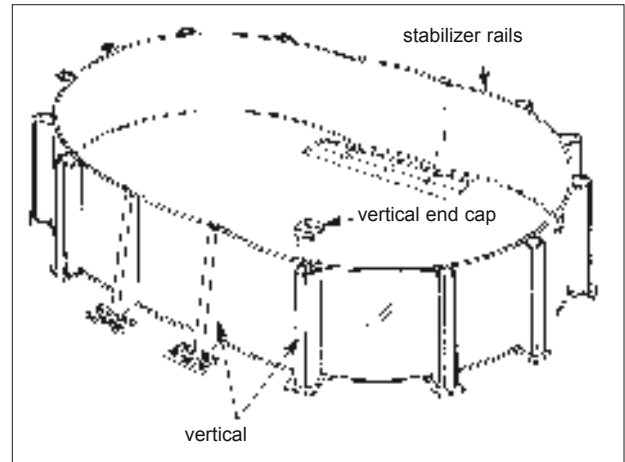

Install the verticals, so that the screw aperture is at the front side on top of the vertical. The construction is connect by screws. Position vertical end cap over vertical (see plan). **A drop of oil on the screws facilitates your work.**

## STEEL TOP RAIL / END SECTION (DIANA)

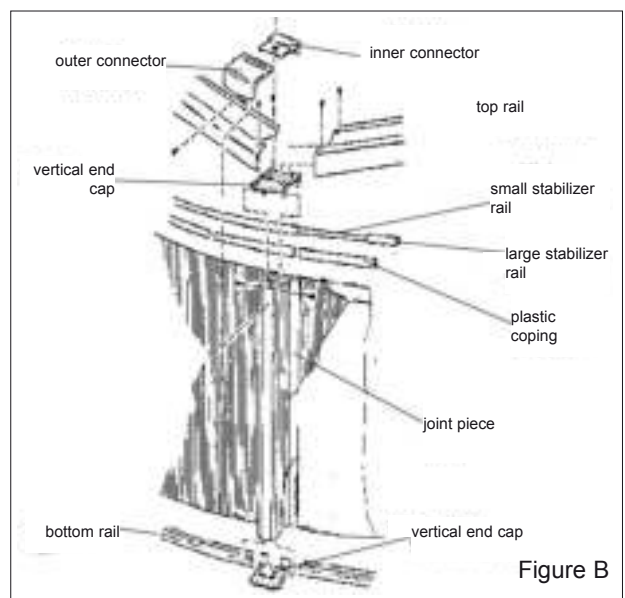

Assemble top connectors: First inner connector. Then slide outer connector onto inner connector (see fig. B).

## INSTALL TOP RAILS + HOLES CHART FOR TOP RAILS (DIANA 6,10 X 3,60 / 7,30 X 3,60)

### Step 13a

There are two different joints, a straight and a round joint. A, B, C straight / D round (see fig. 13 A).

Four screws connect the top rails with the vertical end caps. Screw the screws in the right holes of the top rails and vertical end caps.

Follow the measures of the holes chart.

Holes with numbers 1 and 3 are of the inside of the pool.  
Holes with numbers 2 and 4 are of the outside of the pool.

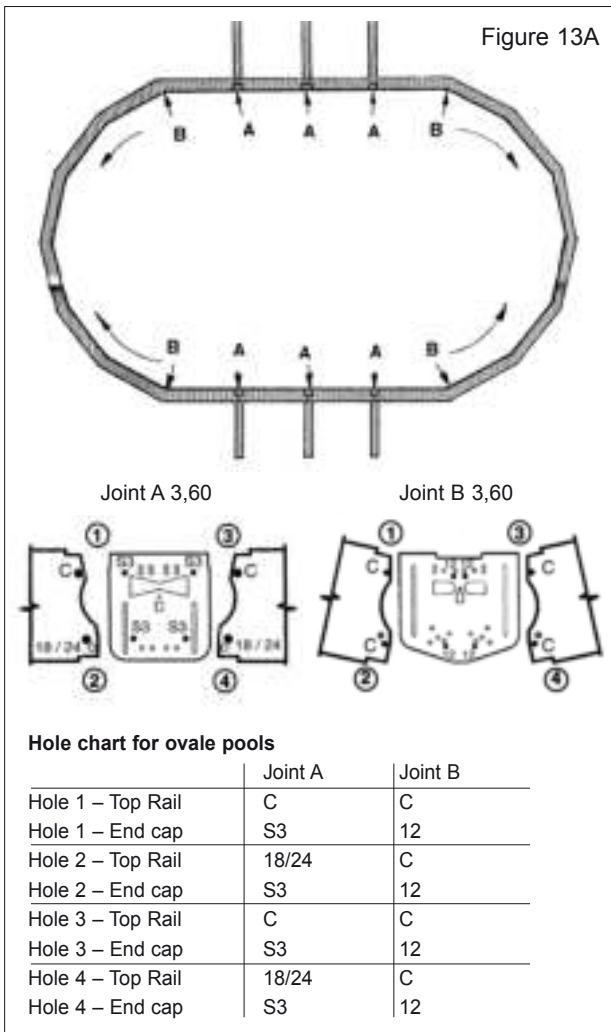

## INSTALL TOP RAILS + HOLES CHART FOR TOP RAILS (DIANA 8,50 X 4,90)

### Step 13b

There are two different joints, a straight and a round joint. A, B, C straight / D round (see fig. 13 B).

Four screws connect the top rails with the vertical end caps. Screw the screws in the right holes of the top rails and vertical end caps.

Follow the measures of the holes chart.

Holes with numbers 1 and 3 are of the inside of the pool.  
Holes with numbers 2 and 4 are of the outside of the pool.

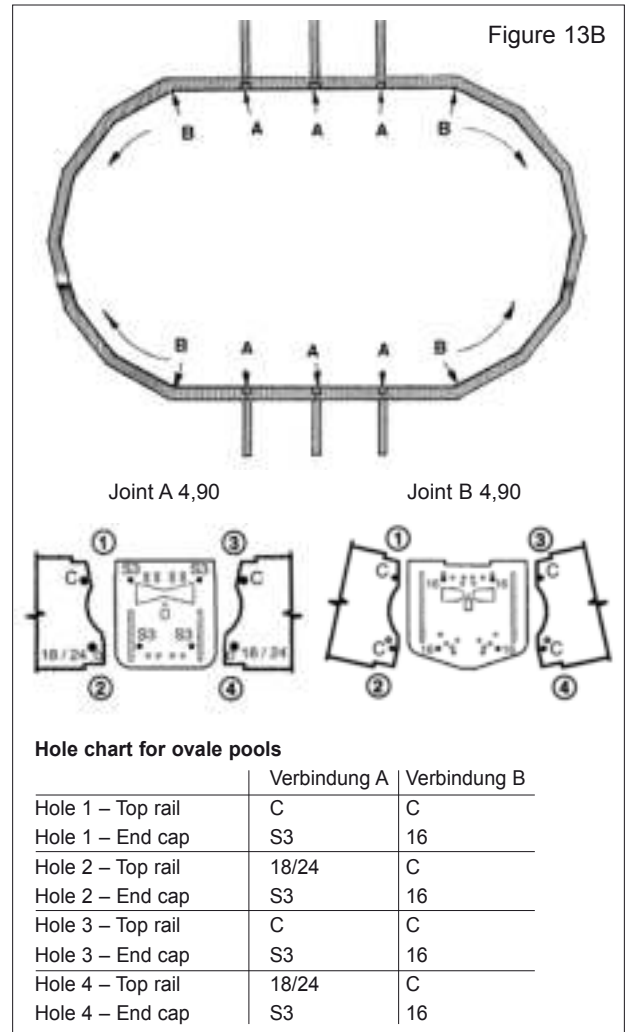



## COVE

### Step 14

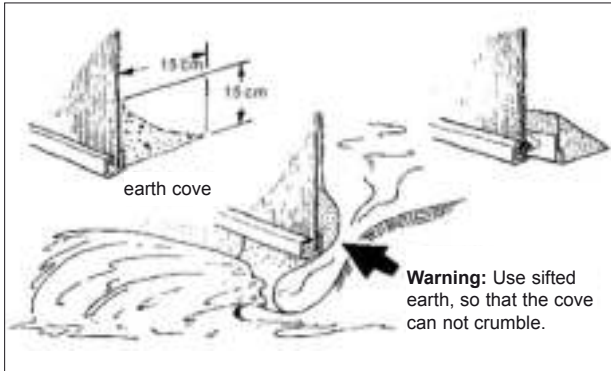

Important step: Make on the inside of the steel wall a slant elevation of sifted earth of around 15 cm high and wide. This is a vital structural element that prevents water pressure from forcing the pool liner out under the bottom rail.

## LINER SEAM POSITIONING

### Step 15

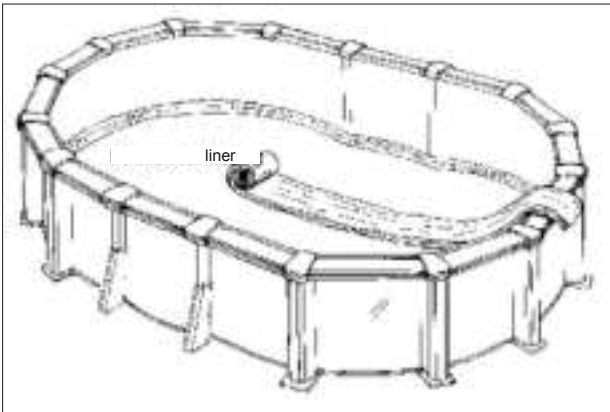

Check the pool floor again for stones, glass and other sharp objects. Fill in all footprints and other unevenness on pool floor. As floor sealing and extra protection of your liner it is advisable to cover the floor with water-resistant underlay, that you can fasten with tape to the underside of the steel wall. Now place the liner on the top rail and check as indicated.

Note: The embossed side of the liner will be the water side.

## STRETCH LINER

### Step 16

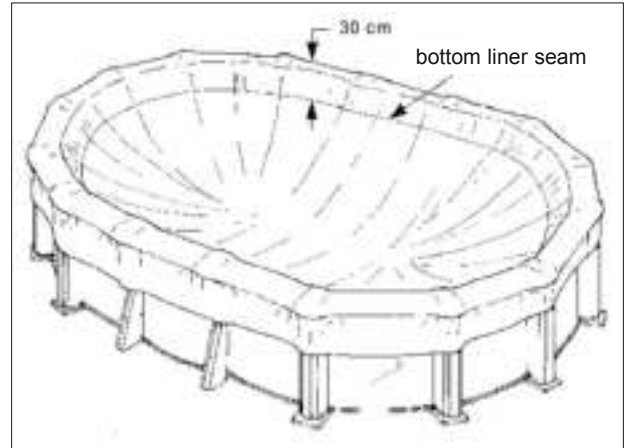

Work in both directions with unfolding the liner and drape it over the top rail and down the sides for about 60 cm. The liner should be about 40 cm above the pool floor in the center only. The bottom edge seam of the liner should be inside the pool about 30 cm from the top rails (see plan).

## FILL POOL

### Step 17

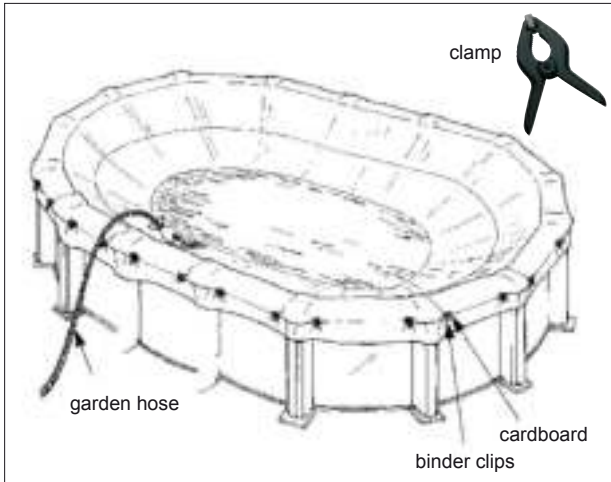

Before filling the swimming pool, hold the liner in place by attaching two binder clips over folded cardboard on the underside of each top rail. Because of the water weight, the liner will be stretched with no wrinkles. Check during filling the pool the liner for extreme tautness. Binder clips do not self-release, so release binder clips with extreme tautness and allow the liner to feed back into the pool until the desired tautness is achieved and re-clamp the binder clips. Remember that you are monitoring a minimum tightness of the liner over rail that will control the liner seating itself against the pool floor and up the side with no wrinkles. When the water (5 cm) is covering the pool floor, the liner on the pool floor must be without pleats and wrinkles.

If this occurs, pull and lift the liner wall just enough to stretch out wrinkles or pleats by the water weight. There should be just barely enough tension on the liner, until the floor is filled with approximately 20 cm water and the liner is connected against the metal wall.

The clamps can be bought at several tool shops (Preferably use synthetic clamps).

## CONTINUE FILLING POOL

### Step 18

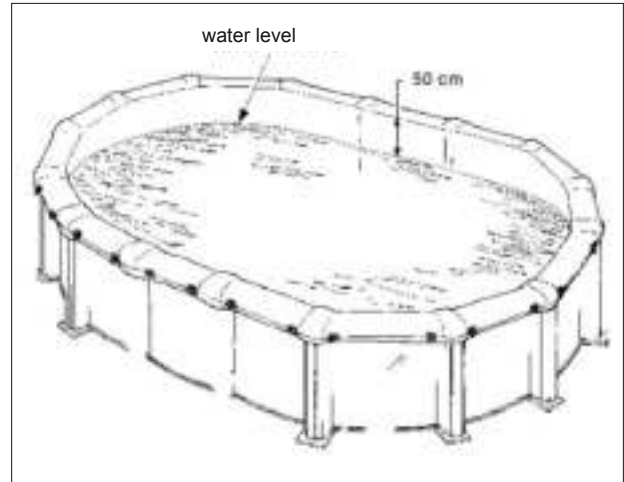

After the pool is filled, the bottom liner seam of the liner must be totally around in the pool must be close to crossing of the bottom wall. Do not worry about the strength of the liner, the strength is calculated on 1,5 x the original size. When the bottom liner seam is not on the right place, there is a chance that you have not enough liner left to place on the top border, so that you have to start again with placing the liner.

## PROCEDURE TO ATTACH LINER

### Step 19

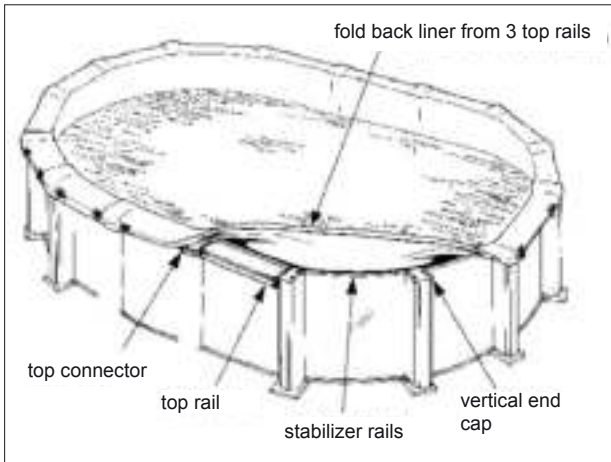

With the help of two or three people, raise and hold the liner up from any three top rail sections. Be careful and never allow the liner to fall back into the pool. When 1 man is holding the liner, the other folds back the vertical end caps, the top rails and top connectors from three top rails (see plan).

## INSTALL COPING AND STABILIZER RAILS

### Step 20

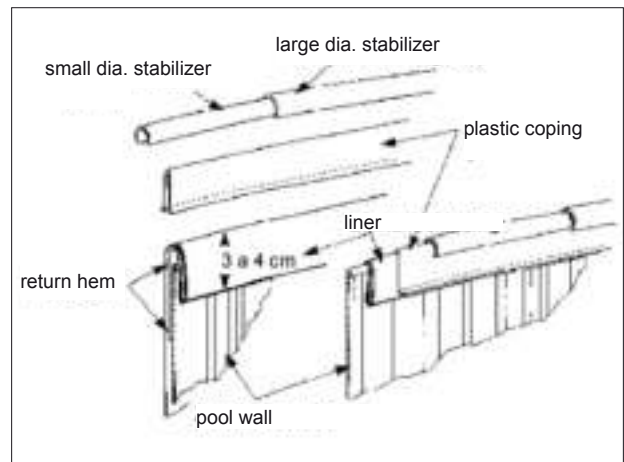

Make a return hem as illustrated and smooth the liner against the wall (see plan). Place the coping over the liner and the stabilizer rails over the coping after pushing it together about 15 cm. Replace all parts removed in step 19 and repeat the same steps for all 3 top rails until you assembled the entire pool.

Now assemble the skimmer, inlet and filter as indicated on the special enclosed instruction. Then fill the pool to the indicated level on the skimmer plate.

## SUPPLEMENTARY INSTRUCTIONS FOR BUILDING A POOL IN THE GROUND



To avoid that material rolls onto the site where the pool is to be constructed, the location where the pool is to be constructed must be in the most elevated part of the garden. The surrounding landscape should be lower than the pool. Attention, the water level of the pool should also be above the groundwater level during the winter (water level 15 cm below the inlet).

The specific installation such as seen in Figure 2 serves only as a reference and is not representative for all pool installations. The parts which may need special materials are the lighting and chloride installations.

### EXCAVATING

1. The circumference of the excavation is the same as the size of the pool plus 60 cm around the whole pool. Determine the size of the excavation pertaining to the size of the pool and use for this the extensive installation instruction delivered with the pool. (Attention, the soil should be at least 15 cm white sand or stabilized sand; on top of that we recommend a layer of styrodur or a protective blanket.)
2. The depth of the excavation is dependent on the height of the pool and desired terrace. Use the size such as seen in Figure 1 to calculate how deep the excavation should be.
3. After the pool is excavated, the frame and the wall should be installed according to the installation instruction delivered with the pool.

### INSTALLATION OF SKIMMER AND INLET

The skimmer and the inlet have to be installed before the pool is filled with water and before the pool is filled up with stabilized sand. During the installation of the internal lining and the skimmer, the lead through for the skimmer may not be created yet. Install the inlet and gasket. Remove the internal lining from the inlet opening and install the valve delivered with the skimmer.

### PLUMBER'S WORK

In order to prevent that the hoses move up and down, you should connect the skimmer and the inlet with rigid PVC to the filter (Figure 2). If you are using flexpipe, you need to make sure that this pipe is not bent, before you fill up the rest of the pool. Install the pump as closely as possible to the pool in connection with the drawing in of the pump. If this pump is a Doughboy Pool Powerpack, then you should place it below the water level.

### FILLING THE POOL

First fill the pool with water up to approximately 5 cm away from the top edge. This procedure is absolutely necessary to absorb the pressure performed on the wall during the application of stabilized sand. If the pool is not filled completely with water, this can cause pool failure.

### SHUTTERING

We recommend that you apply a shuttering around the skimmer before the pool is filled up. A space around the skimmer and any other accessories offer the possi-

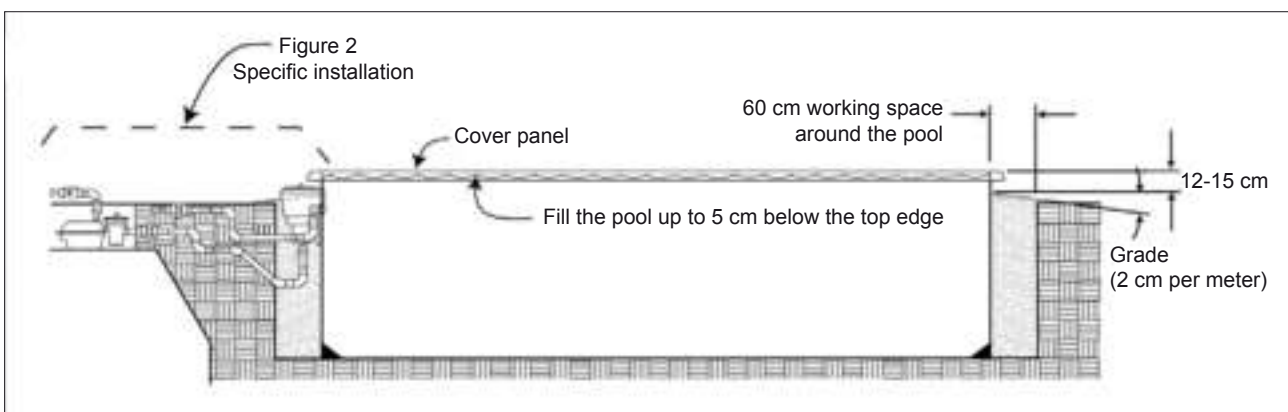

FIG. 1 - CONSTRUCTION PROVISIONS WHEN A POOL IS EXCAVATED

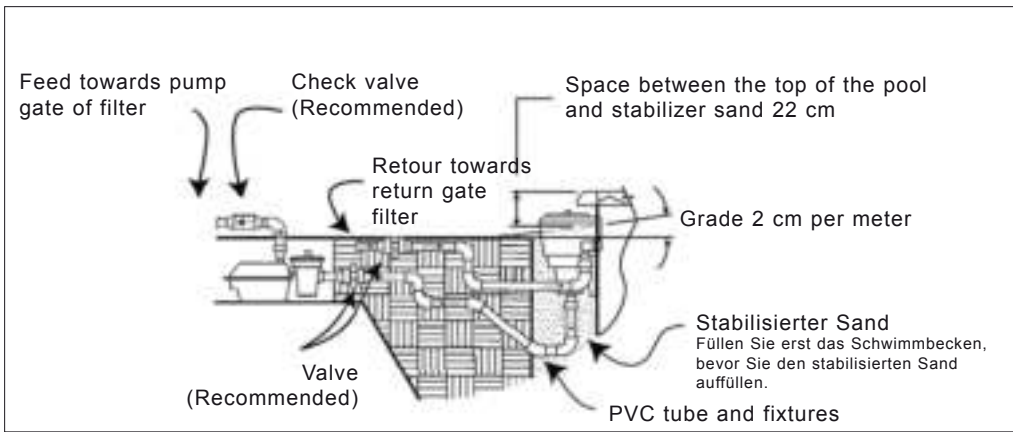

FIG. 2 SPECIFIC INSTALLATION

bility to have easy access for maintenance or repairs.  
**ATTENTION:** If the filling up takes place immediately around the skimmer, it shall be more difficult in the future to check the skimmer during leaks.

Doughboy is in no way liable for the expenses pertaining to the finding and/or repairing of leaks, cutting, breaking off and/or removing of stabilizing sand.

**PREPARATION OF STABILIZER SAND**

Mixing ratio 1 m<sup>3</sup> fluvial sand with 125 kg concrete.

**IMPORTANT WARNING:**

Regardless the method used for the way the stabilized sand is applied, you should pay close attention to the wall of the pool during filling to be sure that the wall does not collapse. If a dent occurs in the pool wall, someone should enter the pool to push it back.

If this is not possible, you should lower the pressure to the pool wall by removing the mixture used to fill up the pool locally again so that the dent can be removed. Then carefully fill up the pool again. You should at all times pay attention to the pool wall until the pool is completely filled up. To prevent rust on the pool wall, the water streaming out of the pool should immediately be removed from the pool wall. For this you should let the top layer run off at least 2 cm such as can be seen from the illustration. After the mixture has been applied completely, you should lower the water level to the top line of the skimmer opening and cut away the liner in the skimmer opening.

**IMPORTANT MESSAGE:**

Piling up of loose material between the mixture and the pool wall may push in the wall. If extra material is placed between the mixture and the cover material to get this at the correct height, you should only use a sturdy mortar.

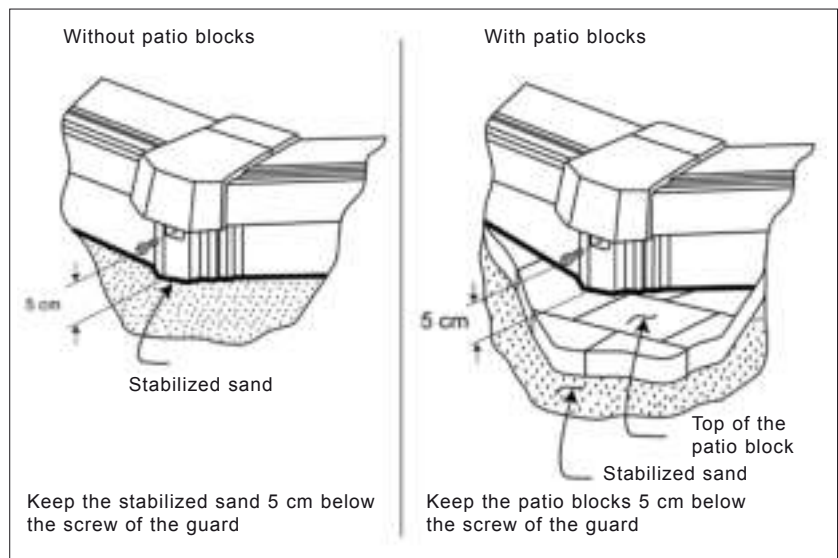

FIG.3 - WITH/WITOUT PATIO BLOCKS

## STANDARD SKIMMER

### MODELS 5-2091-015 INSTALLATION INSTRUCTIONS



Your standard skimmer facilitates the maintenance of your pool. Leaves and floating refuse are taken out of the water and enter into the skimmer basket. Clean the basket regularly to continuously keep your pool clean and hygienic. The numbers indicated between the brackets refer to the numbers of the illustration (Fig 7).

#### Needed tools

- Crosshead screwdriver
- Screwdriver
- Stanley knife

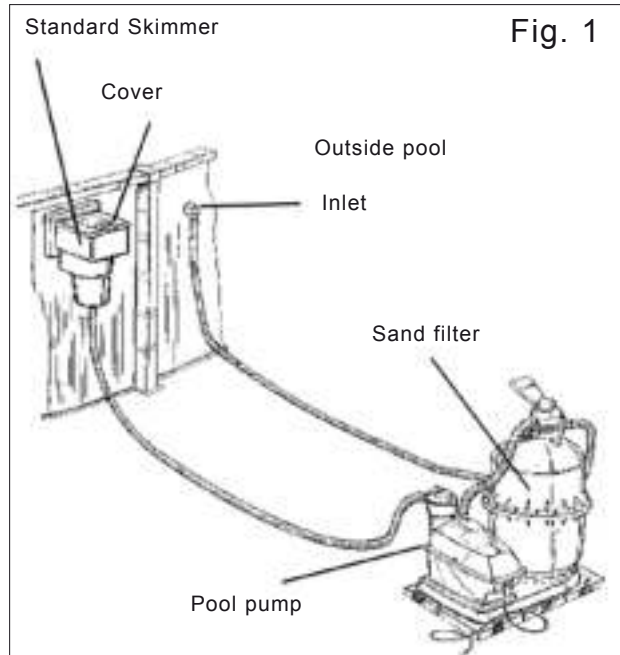

### PREPARATION OF THE POOL

The pool should be built up the correct way based on the pool assembly and installation instructions. Approximately 70 cm water should press against the metal wall, so that there isn't any elasticity anymore against the liner, before the skimmer is installed.

**ATTENTION:** After the skimmer hole is cut open the liner can no longer be moved.

#### Skimmer installation

1. Remove all parts from the carton box. Remove the cover of the skimmer by sliding it to the front and then lifting it; remove the skimmer basket.
2. Fasten the skimmer valve (7) to the skimmer (3) by using three screws (8). Push the skimmer valve into the skimmer so that the foam side is facing the bottom.
3. Install the top skimmer gasket (9) into the square opening of the metal wall; make sure that the gasket is positioned properly in front of the holes. Then fasten the bottom gasket (10) into the vacuum connection. Place the skimmer plate on the inside of the pool, and keep the skimmer on the outside of the pool. First screw tight the top angles with two self tapping screws. Press the self tapping screws through the skimmer plate and press the liner into the openings of the skimmer. Lightly tighten the self tapping screws.

Fig. 2

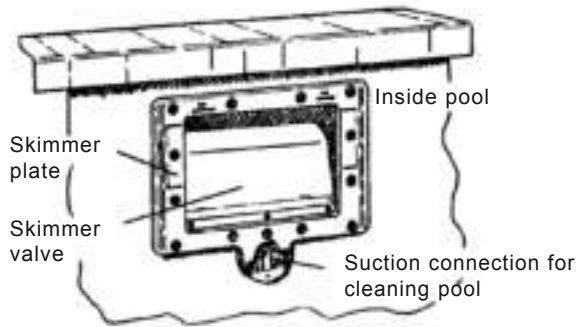

4. Screw the rest of the self tapping screws through the skimmer plate, liner, gaskets, wall and the corresponding openings in the skimmer. Tighten all self tapping screws manually; this to prevent damage to the skimmer plate. With a Stanley knife now cut away the liner on the inside of the skimmer plate; do the same with the vacuum inlet. (Fig 4)

Fig. 3

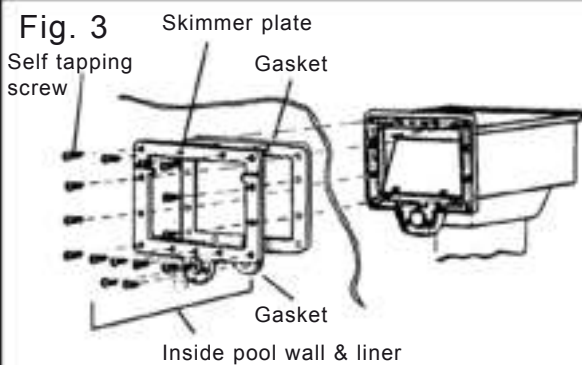

ATTENTION: The gasket around the vacuum connection (10) is necessary to ensure a watertight closure around the vacuum connection during the suctioning off of water. Attach the suction cover (12) and the attachment of the suction cover (11) to the skimmer plate with a screw (8).

Fig. 4

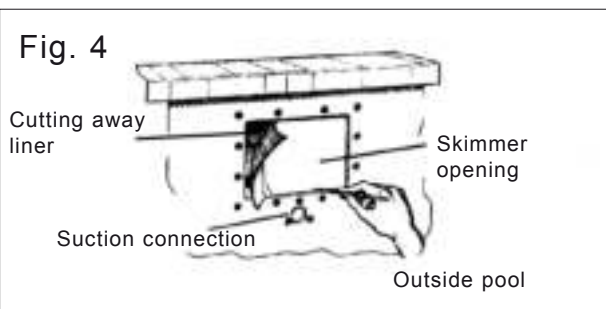

### Installation inlet fixture

1. Install the gasket of the inlet (17) into the wall opening. Insert the inlet fixture (18) through the liner and the wall starting from the inside of the pool. Make a small notch into the liner and press the inlet fixture through.
2. Now screw the inlet (16) onto the inlet fixture; turn it clockwise until the inlet end points towards the bottom.
3. Install the eyeball inserted piece (20) into the eyeball (21). Insert the eyeball with the inserted piece into the inlet fixture, turn the closure (22) on top of that; make sure that the eyeball location stands in the water running off direction of the skimmer opening

### WARNING: Always keep the water level between the water level signs on the skimmer plate.

After installation of the skimmer check if there are leaks when the pool is filled. Continuous leaks can cause damage to the pool wall, so that eventually there is pool failure.

### VACUUMING

Empty the skimmer basket before suctioning.

1. Switch off the pump. Assemble the vacuum nozzle, handle and hose. A proper flexible hose provides the best suction results. Attach the free end to the vacuum adaptor (13).
2. Switch on the pump. Keep the free end of the hose against the outlet of the inlet fixture. Because of this air shall pass through the hose. When bubbles no longer exit from the vacuum nozzle, all air has been removed (please refer to Figure 5/6).

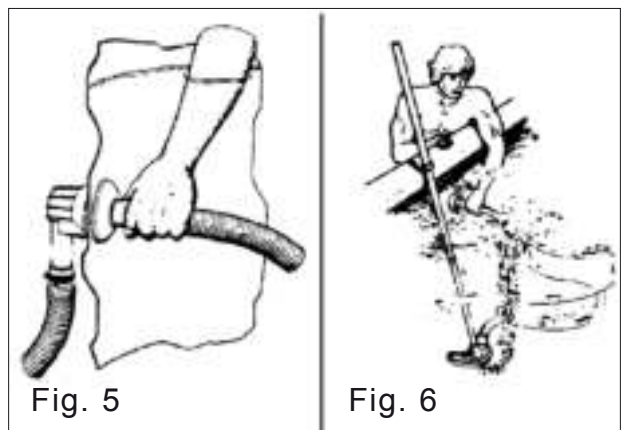

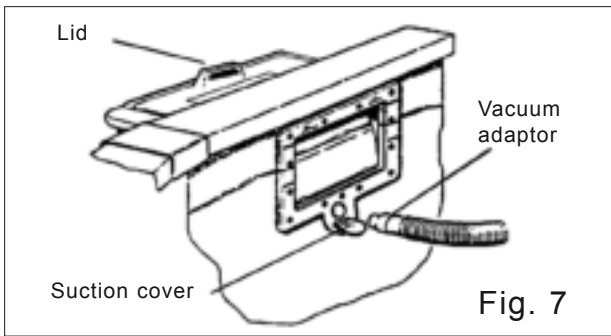

3. Fold the cover of the vacuum opening (12) so that it points towards the bottom. Insert the tapering end of the vacuum adaptor with the hose attached into the opening by making a turning movement (Fig. 7).
4. The cover (2) has two functions. In the normal position it covers the top of the filter. During suction, this same cover becomes the closing plate for suctioning; make sure that the pump is in the OFF position. Remove the cover, turn it 90° and let it drop to the inside and place it above the basket. Make sure that there is no air under the cover. Trapped air shall make the cover rise.

**Warning:** Never try to install the cover in a suctioning position if the pump is switched on. The cover might suddenly be pulled down due to the strong suction of the pump. You may suffer personal injury to your hands or fingers.

5. When the cover is in place, you can switch on the pump and put into operation the suction of the pool floor.
6. When you are finished suctioning, you have to switch off the pump. Remove the vacuum hose with the vacuum adaptor connected to it from the pool. Clean the skimmer basket and your filter. Relocate the cover to the original position on the top of the skimmer. Switch on the pump to resume the normal operation of the pump.

## STANDARD SKIMMER PARTS

No.	Article	Amt	Description
1	1300-1002	1	Skimmer basket
2	1121-1506	1	Skimmer cover
3	1121-1864	1	Skimmer
4	360-1794	1	Sticker
5	1121-1358	1	Skimmer valve
6	340-1600	1	Attachment skimmer valve
7	1107-1275	1	Skimmer valve plus attachment
8	330-1008	4	Screws
9	307-1029	1	Top of gasket
10	307-1030	1	Bottom of gasket
11	340-2089	1	Attachment suction cover
12	348-1028	1	Suction cover
13	340-1590	1	Water suction adaptor
14	330-1004	15	Screws
15	340-2090	1	Skimmer plate
16	340-1591	1	Inlet
17	307-1031	1	Gasket inlet
18	340-1592	1	Inlet adaptor
19	340-1594	1	Closure disk
20	340-1595	1	Eyeball attachment
21	348-1027	1	Eyeball
22	340-1593	1	Closure for the inlet
23	360-2023	1	Operating Instructions Label



## PREPARING FOR WINTER

When the swimming season is over, you have to follow the instructions to get your pool ready for winter.

**ATTENTION!** Do not remove all the water from your pool and also do not remove the liner. An empty pool can namely cause pool failure.

### Lower the water level

- Lower the water level in your pool so that it is approximately 6" (15 cm) below the inlet fixture; maintain this water level by checking it regularly.
- If you have a skimmer, then absolutely do not let the water freeze in the skimmer but rather drain this water.

### Check all screws and connections

- Make sure that all installation connections and parts are positioned correctly and that the pool wall is not moved away from the bottom rails.
- Make also sure that all connections are water tight.  
Check if there is rust
- Correct all damages or rust spots with a varnish stick.

### Check the liner (interior tarpaulin)

- Make sure that the top of the liner is still overhanging the pool wall attached to the plastic edge. Do not remove the liner from your pool. Upon removal of the liner of the pool the warranty becomes void. Do not pump dry all the water from the pool during the winter.

### Leaks found

- Make sure that there aren't any leaks in the liner.  
Leaks during the winter can cause serious damages to your pool.

### Pool accessories

- Remove all pool accessories from the pool, including the ladder. Leave the skimmer and inlet fixture in place.

### The filter

- Disconnect the filter from your pool and follow the filter instructions for maintaining the filter during the winter.  
Clean the pump and the filter for the winter (frost free).



### Anti-freeze liquid

This liquid can be used without problems in combination with chloride products. Upon finding algae present first apply a 'shock treatment.' The liquid should be dissolved in a pail of water, spread out equally across the water surface. During the dosage the pump should be in operation. The dosage is 0.5 litres per 10 m<sup>3</sup>, after approximately four weeks 0.3 litres per 10 m<sup>3</sup>.

**ATTENTION!** Never mix the liquid with other pool chemicals or chemicals and always add the product to water, never the other way around.

If you do not adhere closely to the winter instructions, the warranty of your pool may become void. Thus carefully adhere to all instructions for maintaining your pool during the winter.