

2- Leg Height Adjustable Desk

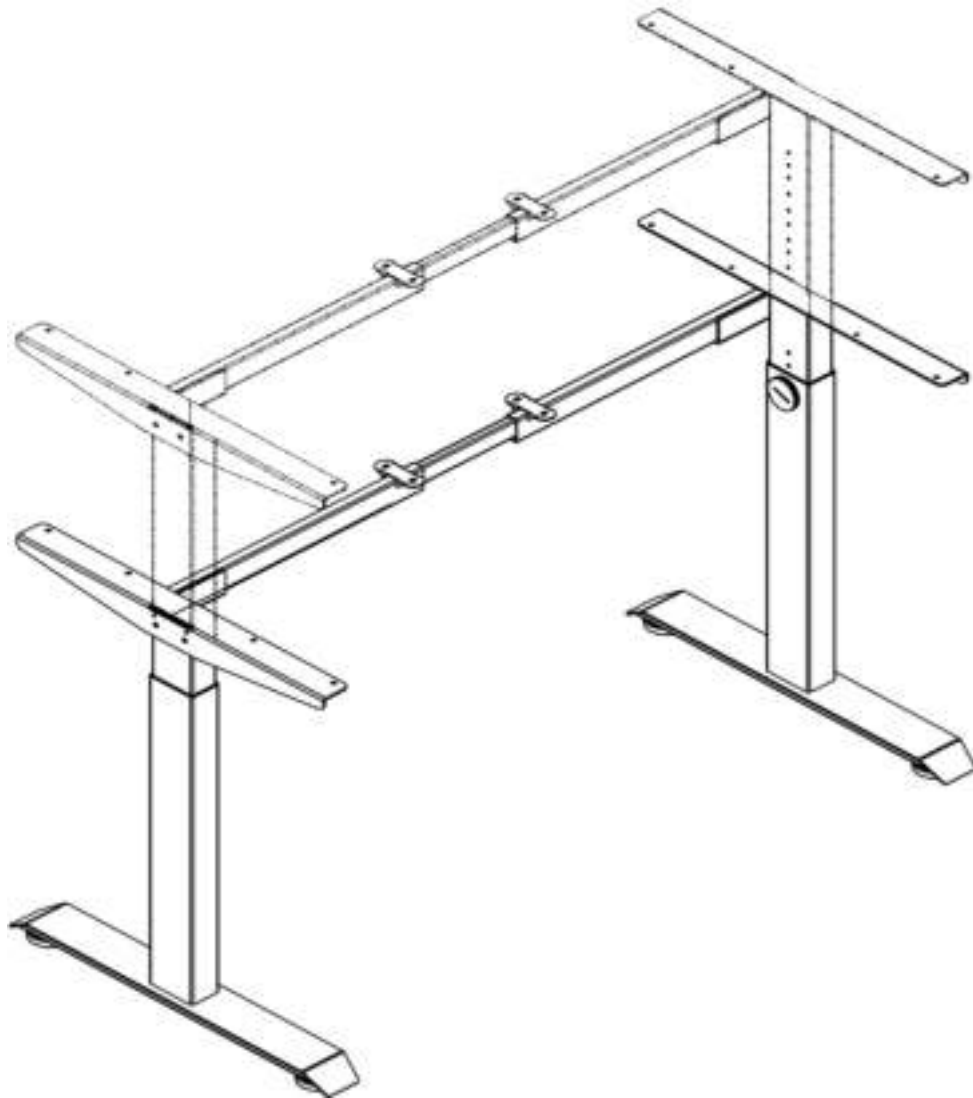

ASSEMBLY & OPERATION MANUAL

Technical Specification

Height Range	620 - 840 mm (excluding desktop)
Base Width	1005 -1600 mm
Weight Capacity	100 kg

Table Of Contents

Parts & Components..... Page 3

Explore Diagram..... Page 4

Assembly Instructions..... Page 5-6

Operation Instructions..... Page 7

Parts & Components

Tools Required

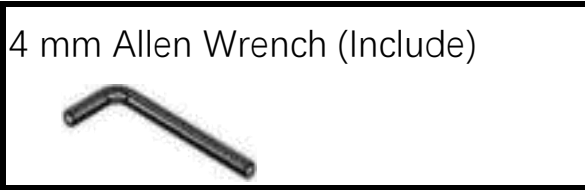

Components Included

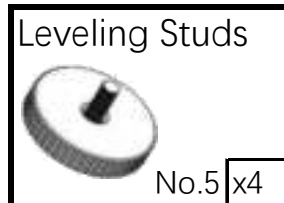
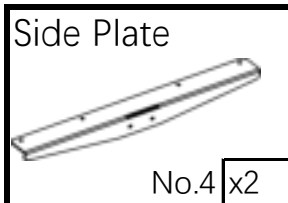
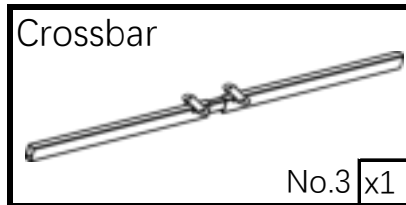
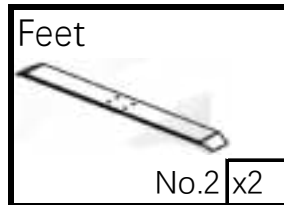
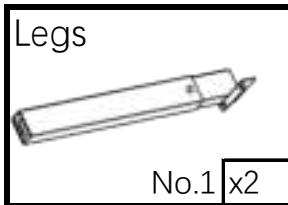

Hardware Frame System

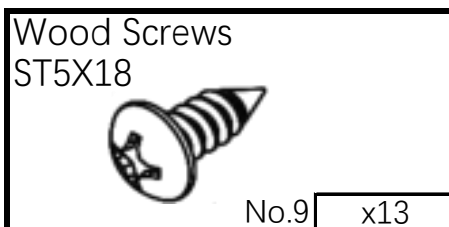
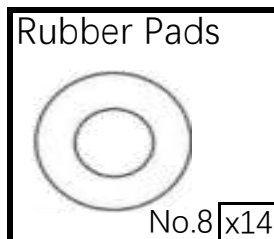
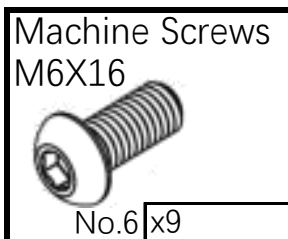

Components Diagram

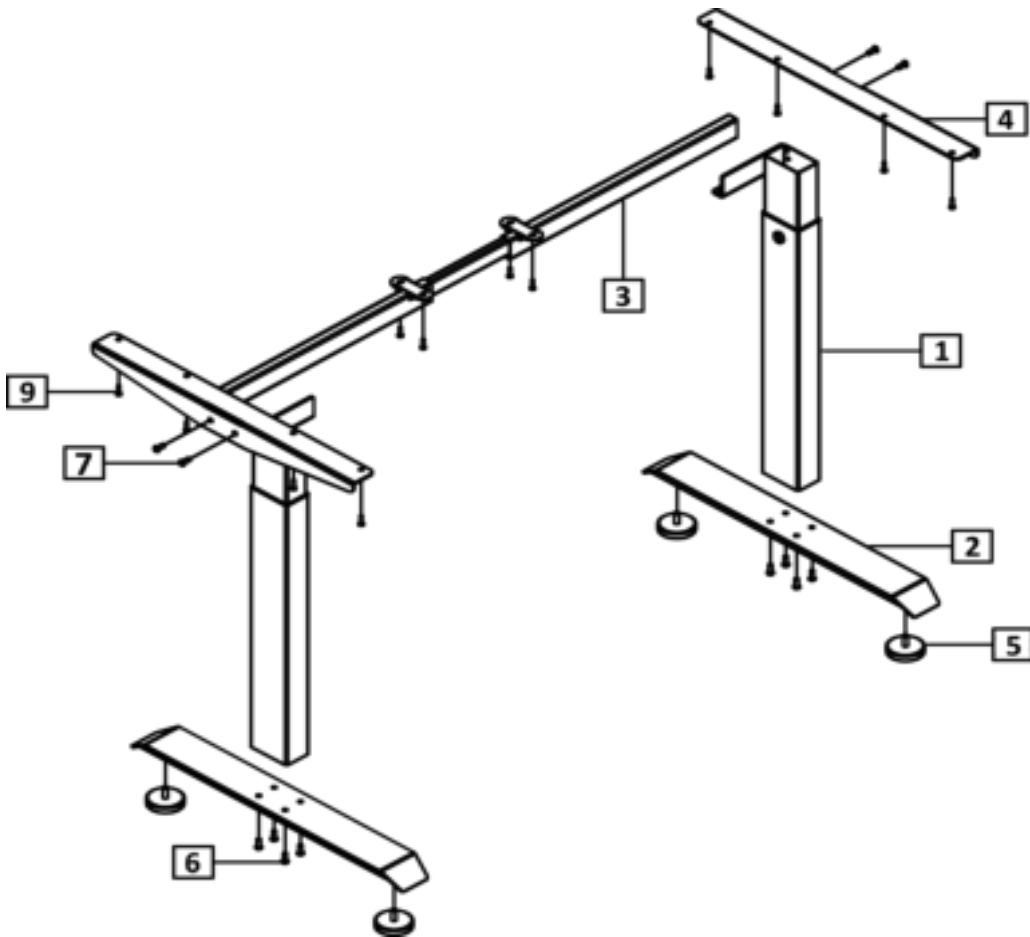

No	Description	Qty
1	Legs	2
2	Feet	2
3	Crossbar	1
4	Side Plate	2
5	Leveling Studs	4
6	Machine Screws M6x10	5
7	Machine Screws M6x16	9
8	Rubber Pad	14
9	Wood Screws ST4x16	13

Assembly Instruction



BEFORE YOU BEGIN Lay out all components and hardware to ensure that you have all the parts listed on the parts page.

Step 1

Extend the Crossbar("A") and assembly lift legs according "B" diagram.
Assembly table feet via 8 M6x16 and 4 leveling studs.

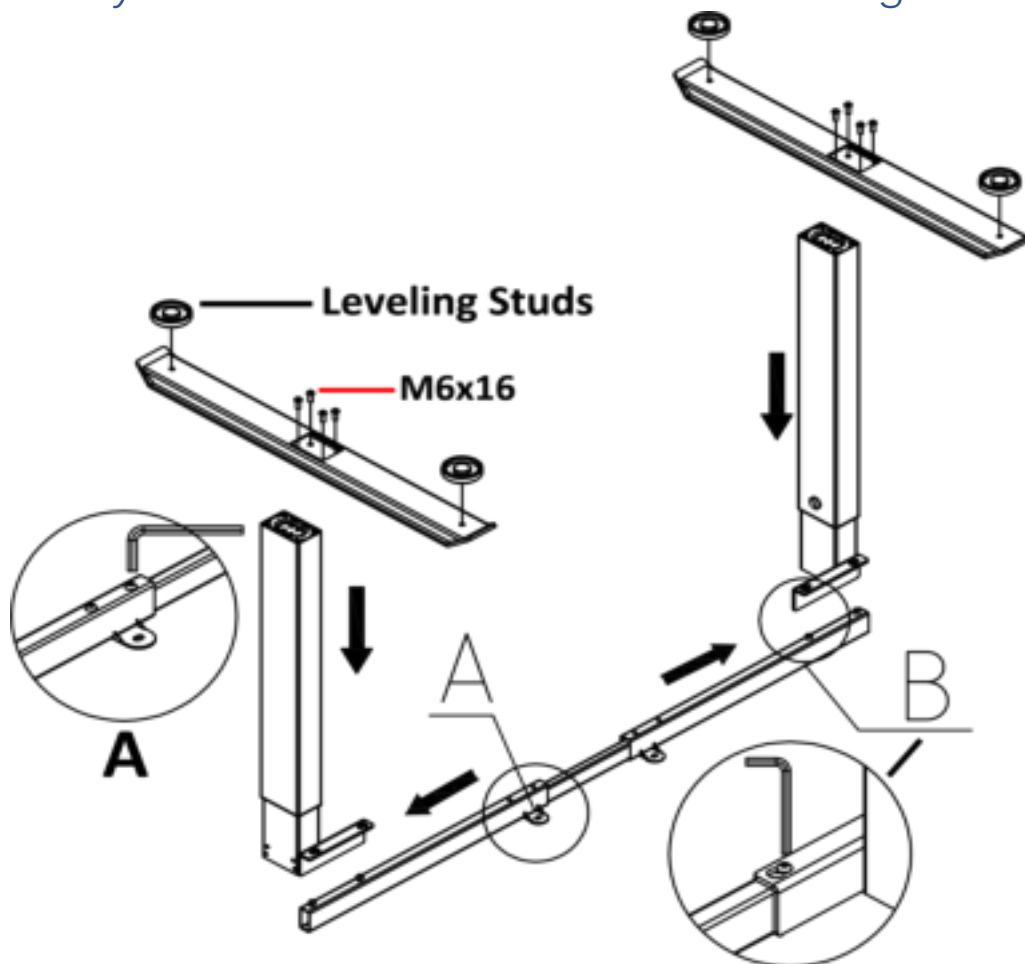

Step 2

Assembly side plate via 4 M6x10.

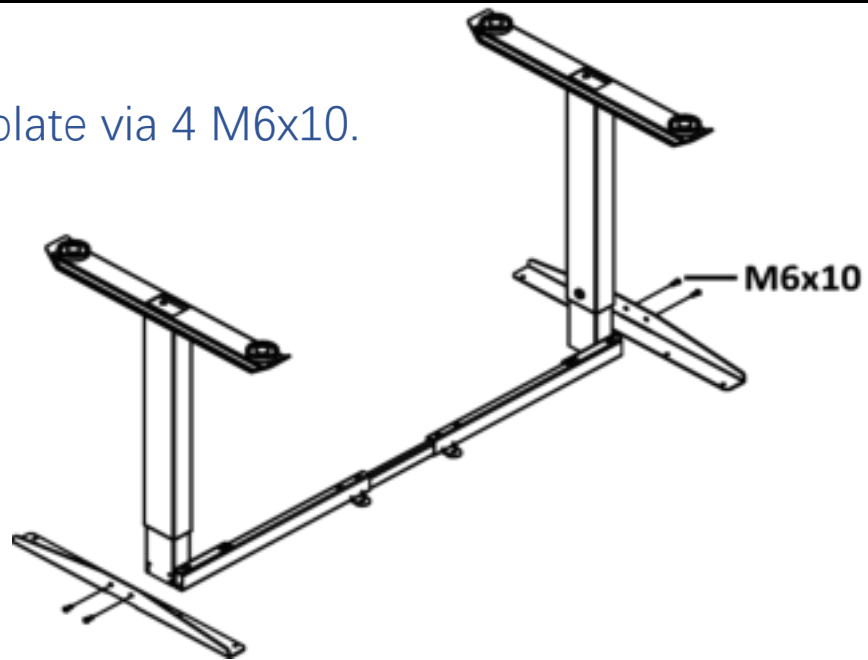

Step 3

Use 12 ST5x18 assembly desktop.
Then tighten crossbar screw according "C" diagram.

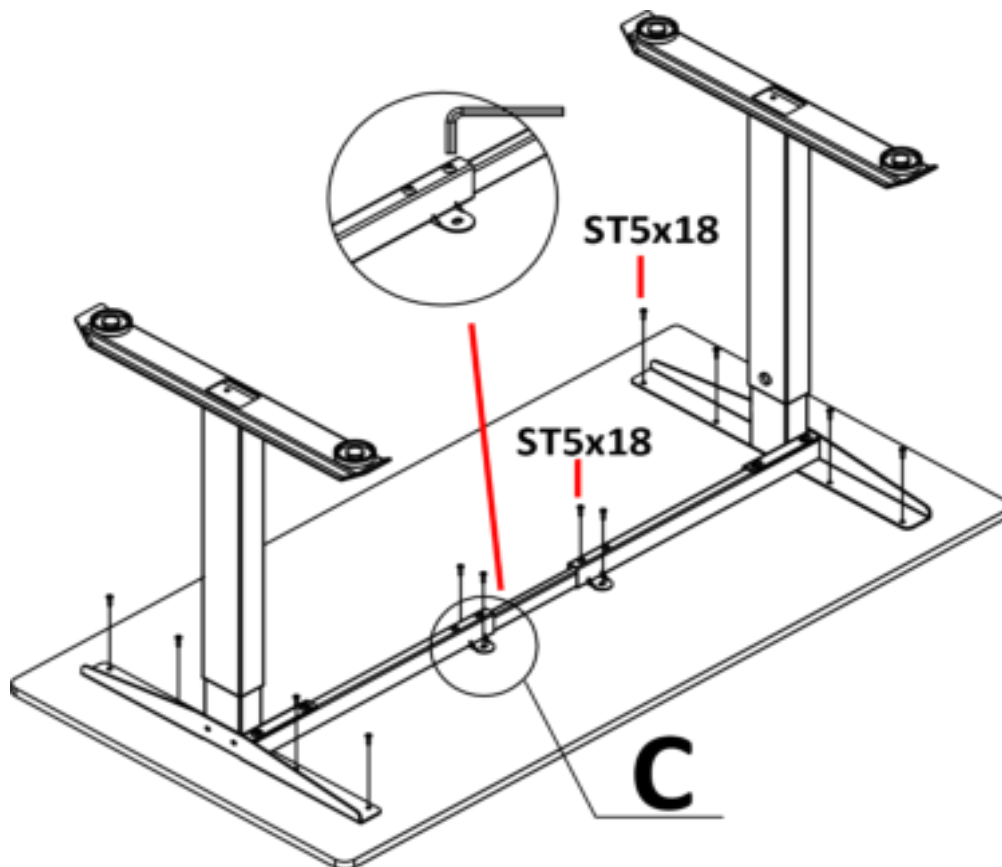

Operation Instruction

Turn screw to adjust height via screwdriver

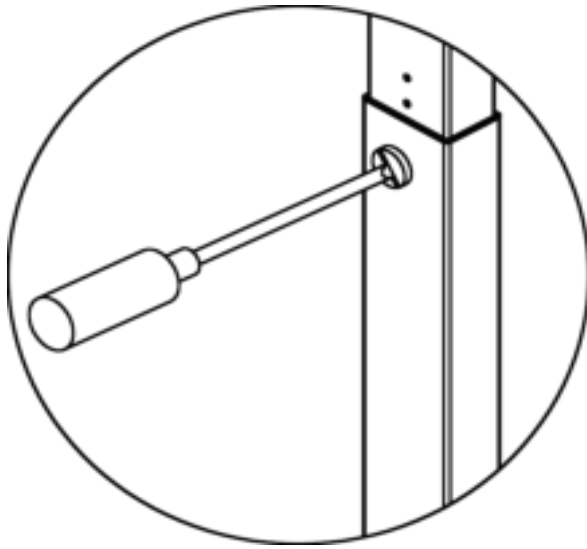

At the highest point, the column will have 9 holes on the outside.

