

# oeuf®

## MINI LIBRARY

ITEM # 1ML002

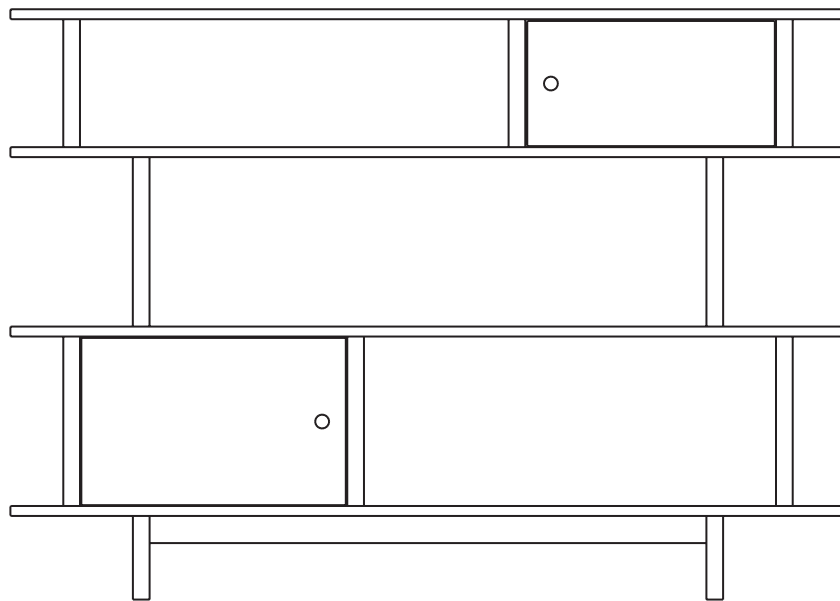

ek10984

**Oeuf LLC** 119 8th Street, Suite 301 | Brooklyn, NY 11215 | USA +1 (718) 965-1216 | [www.oeufnyc.com](http://www.oeufnyc.com)

Distributed internationally by:

*Australia*

**Kido Agencies**

Postal: PO Box 6039  
Alexandria NSW 2015  
Australia  
Tel: +61 2 9045 7799  
[info@kidoagencies.com](mailto:info@kidoagencies.com)

*Canada*

**Monte Distribution Inc.**

270 Belfield Rd  
Toronto, Ontario M9W 1H5  
Canada  
Tel: +1 866 604 6755  
[info@oeufcanada.com](mailto:info@oeufcanada.com)

*Korea*

**J2 International Inc.**

(주) 제이투인터내셔널  
서울시 강남구 도산대로 506  
재정빌딩 304호  
Tel: +82 70 8247 7576

*UK*

**Kids At Home Distribution**

Newick Business Centre  
Church Road  
Newick, BN8 4NA  
England  
Tel: +01825 724160

*EU*

**Suede Import**

20 Bis Rue des Champs  
92600 Asnières-sur-Sein  
France  
Tel: +33 (0)1 40 86 06 03  
[suedeimport@yahoo.fr](mailto:suedeimport@yahoo.fr)

*Turkey*

**Operaistanbul**

Cengiz Topel Cad. Tugcular sok.  
No:1 Kat 3 Etiler Istanbul  
Turkey  
Tel: +90 212 321 8132  
[info@operaisatnbul.com](mailto:info@operaisatnbul.com)

*China*

**Arketype Limited**

7F Metro Loft, 38 Kwai Hei St.  
Kwai Chung, N.T.,  
Hong Kong  
+852 2110 9400  
[www.arketype.com](http://www.arketype.com)

Made in Latvia

## ENGLISH

Important information  
Read carefully.  
Keep this information for further reference.

### WARNING

Serious or fatal crushing injuries can occur from furniture tipping over. To prevent this furniture from tipping over it must be permanently fixed to the wall.

## DEUTSCH

Wichtige Information  
Sorgfältig lesen  
Diese Information aufbewahren

### ACHTUNG

Wenn Möbelstücke umkippen, können ernste oder lebensgefährliche Verletzungen durch Einklemmen die Folge sein. Um zu verhindern, dass das Möbelstück umkippt, muss es fest an der Wand verankert werden.

## FRANÇAIS

Information importante  
A lire attentivement.  
Conserver ces informations pour un usage ultérieur.

### AVERTISSEMENT

Risque de blessure grave en cas de chute du meuble. Pour éviter que le meuble ne bascule, il faut le fixer au mur de façon permanente.

## NEDERLANDS

Belangrijke informatie  
Goed lezen  
Bewaar deze informatie voor toekomstig gebruik

### WAARSCHUWING

Wanneer meubels omvallen, kan er ernstig of levensbedreigend beklemmingsletsel ontstaan. Om te voorkomen dat dit meubel omvalt, dient dit permanent aan de wand te worden bevestigd.

## DANSK

Vigtige oplysninger!  
Læs omhyggeligt.  
Gem disse oplysninger til senere brug.

### ADVARSEL!

Der kan opstå alvorlig eller livsfarlig tilskadekomst, hvis møblet vælter. For at undgå at møblet vælter, skal det fastgøres permanent til væggen.

## NORSK

Viktig informasjon  
Les nøye.  
Ta vare på denne informasjonen for fremtidig bruk.

### ADVARSEL

Alvorlige ulykker kan skje som følge av møbler som velter. For å forhindre at dette møbelet faller, må det festes permanent til veggen.

## SVENSKA

Viktig information  
Läs noga  
Spara informationen för framtida bruk

### VARNING

Allvarliga eller livsfarliga klämskador kan ske om möbler tippas över. För att förhindra att den här möbeln tippas måste den fästas permanent vid väggen.

## ČESKY

Důležitá informace  
Čtěte pečlivě.  
Ušchovejte pro pozdější použití.

### VAROVÁNÍ

Pokud se nábytek převrhne, může dojít k velmi vážným nebo dokonce fatálním poraněním. Abyste převržení nábytku zabránili, musíte ho natrvalo připevnit ke stěně.

## ESPAÑOL

Información importante  
Leer detenidamente.  
Guarda esta información para consultarla en el futuro.

### ADVERTENCIA

Pueden producirse lesiones graves o fatales si vuelca un mueble. Para evitar que vuelque este mueble, debe fijarse permanentemente a la pared.

## ITALIANO

Informazioni importanti.  
Leggi attentamente.  
Conserva queste informazioni per ulteriori consultazioni.

### AVVERTENZA

Se il mobile si ribalta può causare lesioni da compressione serie o fatali. Per prevenire il rischio che il mobile si ribalti, quest'ultimo deve essere fissato permanentemente alla parete.

## PORTUGUÊS

Importante!  
Ler estas instruções cuidadosamente. Guardar como referência.

### IMPORTANTE

As quedas de móveis podem originar esmagamento ou morte. Estes móveis devem ser fixados à parede para evitar possíveis quedas.

## POLSKI

Ważne informacje  
Przeczytaj uważnie.  
Zachowaj ulotkę na przyszłość.

### UWAGA

Przewrócenie się mebli może doprowadzić do poważnych obrażeń lub śmierci. Aby zapobiec przewróceniu się mebla, należy na stałe przymocować go do ściany.

## LATVIEŠU

Svarīga informācija  
Rūpīgi izlasiet.  
Saglabājiet šo informāciju  
turpmākai uzziņai.

## UZMANĪBU

Mēbeles apgāšanās var radīt  
nopietnas vai nāvējošas traumas.  
Lai šī mēbele neapgāztos, to  
nepieciešams pastāvīgi nostiprināt  
pie sienas.

## EESTI

Oluline teave  
Lugege hoolikalt.  
Säilitage see teave hilisema  
vajaduse tarbeks.

## HOIATUS

Mööbli ümberkukkumisel võivad  
kaasneda tõsised või surmaga  
lõppevad vigastused. Selle  
vältimiseks tuleb mööbel jäädavalt  
kinnitada sein/põranda külge.

## LIETUVIŲ

Svarbi informacija  
Atidžiai perskaitykite. Saugokite  
šias instrukcijas.

## ĮSPĖJIMAS

Jei baldai virstų ar kristų, galima  
smarkiai ar net mirtinai susižeisti,  
todėl baldus reikia pritvirtinti prie  
sienų.

## ROMÂNĂ

Informații importante  
Citește cu atenție.  
Păstrează aceste informații pentru  
refe- rințe ulterioare.

## ATENȚIE!

Pot surveni răni grave dacă te  
împiedici de obiectele de mobi- lier.  
Pentru prevenirea rănilor, fixează  
mobila pe perete.

## SLOVENSKY

Dôležité informácie!  
Čítajte pozorne.  
Informácie si uschovajte pre prípad  
po- treby.

## UPOZORNENIE

Prevrhnutie nábytku môže spô-  
sobiť vážne či smrteľné zranenia.  
Aby sa predišlo prevrhnutiu  
nábytku, upevnite ho ku stene.

## SLOVENŠČINA

Pomembne informacije  
Pozorno preberite.  
Shranite navodila za morebitno  
ponovno uporabo.

## OPOZORILO

Če se pohištvo prevrne, lahko pri-  
de do resnih telesnih poškodb. Da  
bi preprečili nevarnost, da se to  
pohištvo prevrne, mora biti  
pritrjeno na steno.

## TÜRKÇE

Önemli bilgi  
Dikkatli okuyunuz.  
Bu kılavuzu ilerde gerekebileceği  
için saklayınız.

## UYARI

Mobilyanın devrilmesi sonucu  
ölümcül veya ciddi yaralanmalar  
meydana gelebilir.  
Devrilme riskini önlemek için  
mobilyanın duvara sabitlenmesi  
gerekmetedir.

## РУССКИЙ

Важная информация  
Внимательно прочитайте.  
Сохраните эту информацию.

## ВНИМАНИЕ

Опрокидывание мебели  
может привести к серьезным  
или смертельным телесным  
повреждениям. Для  
предотвращения  
опрокидывания мебель должна  
быть постоянно прикреплена к  
стене.

## ΕΛΛΗΝΙΚΑ

Σημαντική πληροφορία  
Διαβάστε προσεκτικά  
Φυλάξτε αυτή την πληροφορία  
για μελλοντική αναφορά.

## ΠΡΟΕΙΔΟΠΟΙΗΣΗ

Σοβαροί ή μοιραίοι  
τραυματισμοί από σύνθλιψη,  
μπορεί να συμβούν από το  
αναποδογύρισμα επίπλου.  
Για να προλαμβάνεται το  
αναποδογύρισμα ενός επίπλου,  
αυτό θα πρέπει να είναι μόνιμα  
στερεωμένο στον τοίχο.

## 한국어

중요한 정보.  
꼼꼼히 읽어주세요.  
추후 참고를 위해 설명서를 잘 보관해 주  
세요.

## 경고

가구가 넘어지면 심각한 부상이 발생할  
수 있습니다. 가구가 넘어지는 것을 예  
방하려면 반 드시 벽에 고정시켜야 합니  
다.

## 中文

警告  
重要信息  
请仔细阅读  
保留此信息, 以便日后参考。

## 警告

家具倾覆可能导致严重或致命的伤  
害。  
为防止倾覆, 家具必须永久与墙面连  
接 固定。

## 日本語

この説明書には重要な情報が含ま  
れています。説明書をよくお読み  
になり、正しくご使用ください。  
この説明書は、いつでも参照でき  
るように大切に保管してくださ  
い。

## 警告

家具の転倒により、家具の下敷き  
になって大ケガ、あるいは生命に  
かかわるような傷 害を負う危険が  
あります。家具の転倒を防ぐた  
め、家具はしっかりと壁に固定し  
てください。

## 繁中

重要資訊  
請仔細閱讀。請保留此份資料,以供  
未來參考。

## 警告

請留意家具傾倒可能造成的嚴重傷  
害。家具須 上牆固定,以免發生傾倒  
的危險。

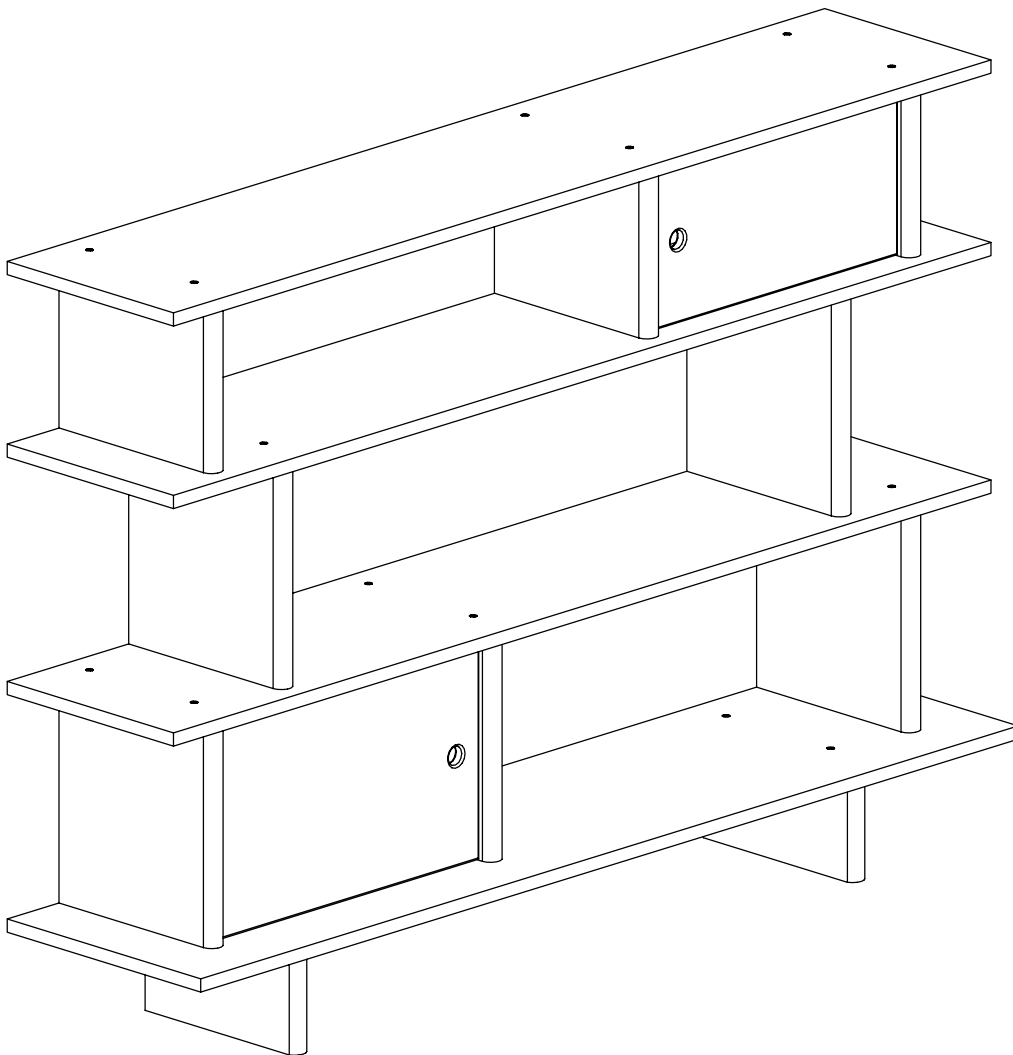
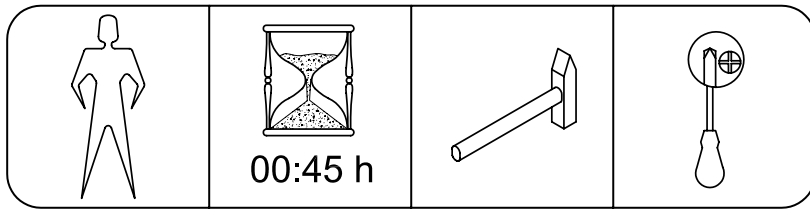





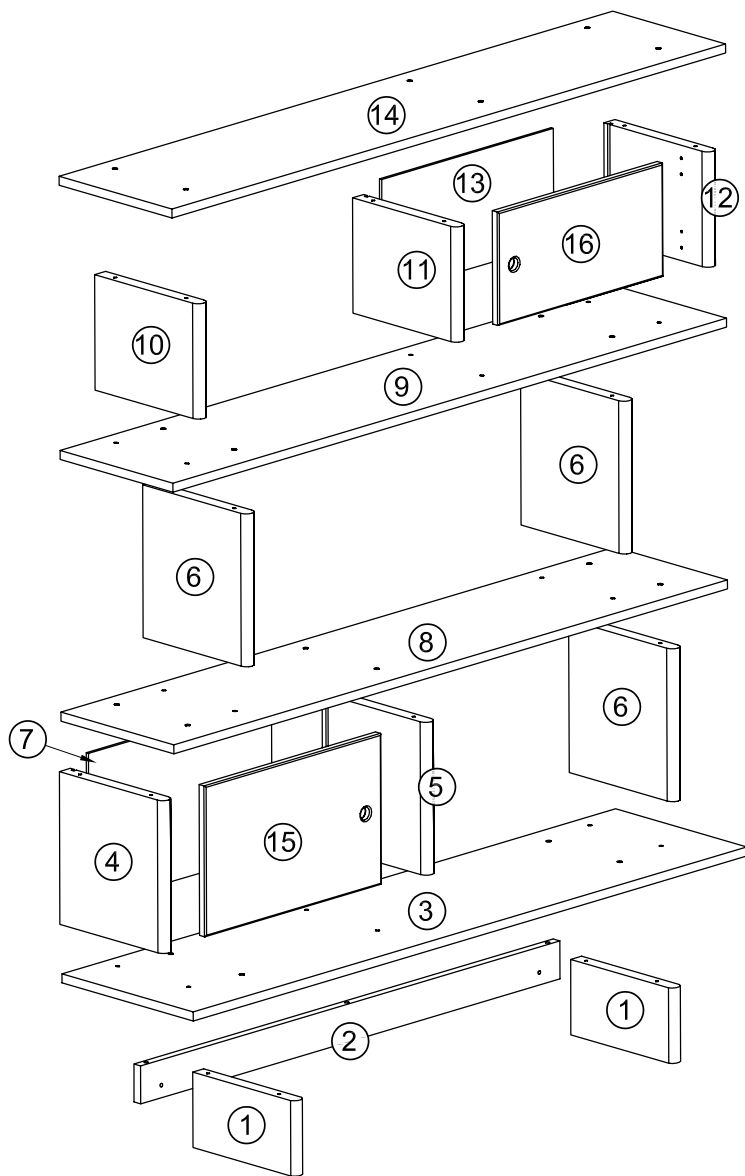

17.06

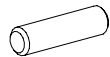
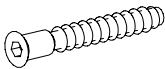
10984

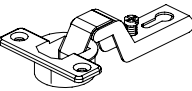
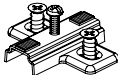

Pieces-Nr.	Quantites	Dimensions, mm
1	2	151 x 275 x 30
2	1	1136 x 76 x 18
3	1	1500 x 355 x 18
4	1	306 x 280 x 30
5	1	306 x 280 x 30
6	3	306 x 280 x 30
7	1	496 x 306 x 6
8	1	1500 x 305 x 18
9	1	1500 x 305 x 18
10	1	231 x 280 x 30
11	1	231 x 280 x 30
12	1	231 x 208 x 30
13	1	467 x 231 x 6
14	1	1500 x 305 x 18
15	1	478 x 302 x 16
16	1	447 x 227 x 16

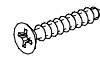

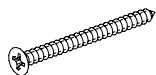
A		Ø8x30	3 pcs
B		Ø7x50	38 pcs
C			1 pc
D			4 pcs
E			4 pcs

F			2 pcs
G		Ø3.5x15	10 pc
H			2 pcs
I		Ø8x40	2 pcs
J		Ø4x50	2 pcs

E		4 pcs
---	---	-------

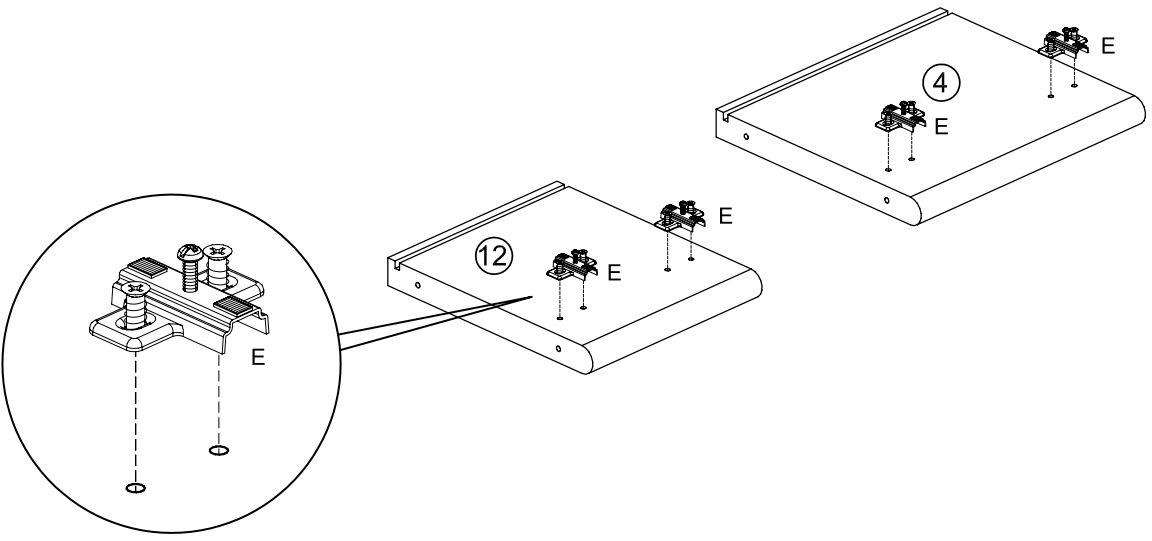
1

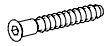

A		Ø8x30	3 pcs
B		Ø7x50	2 pcs
C			1 pc

2

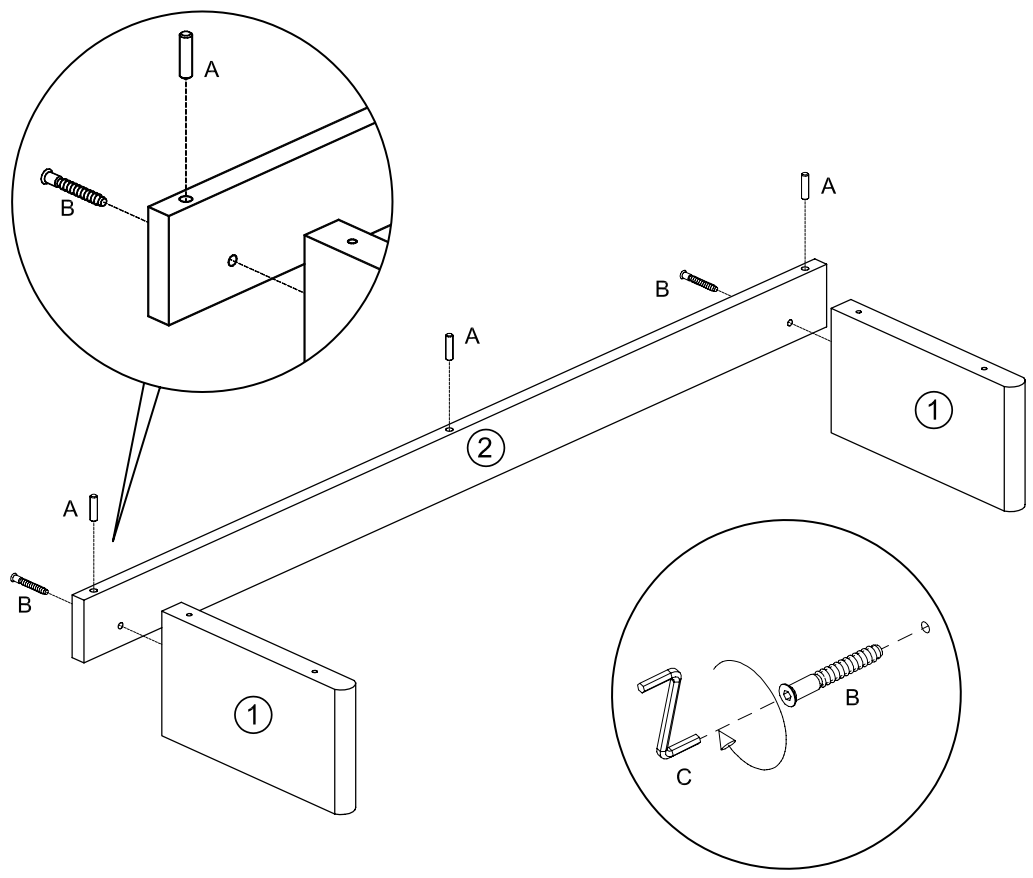

B		4 pcs	C		1 pc
---	---	-------	---	---	------

3

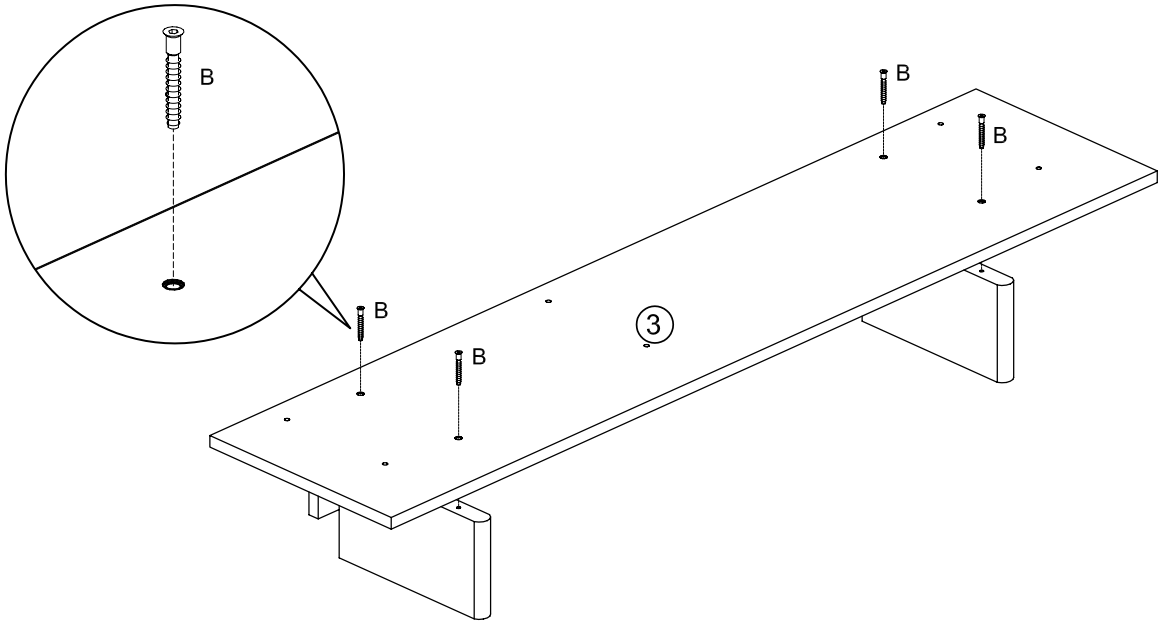

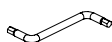
B		6 pcs	C		1 pc
---	---	-------	---	---	------

4

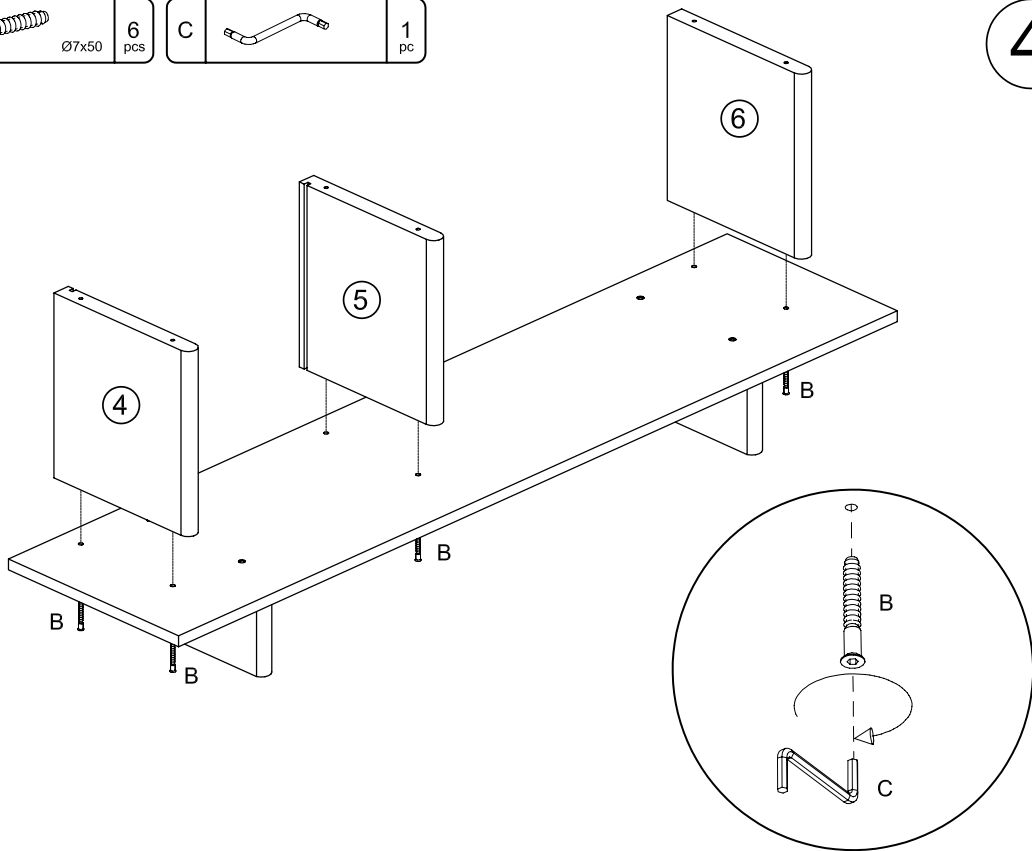

B		Ø7x50	6 pcs
C			1 pc

5

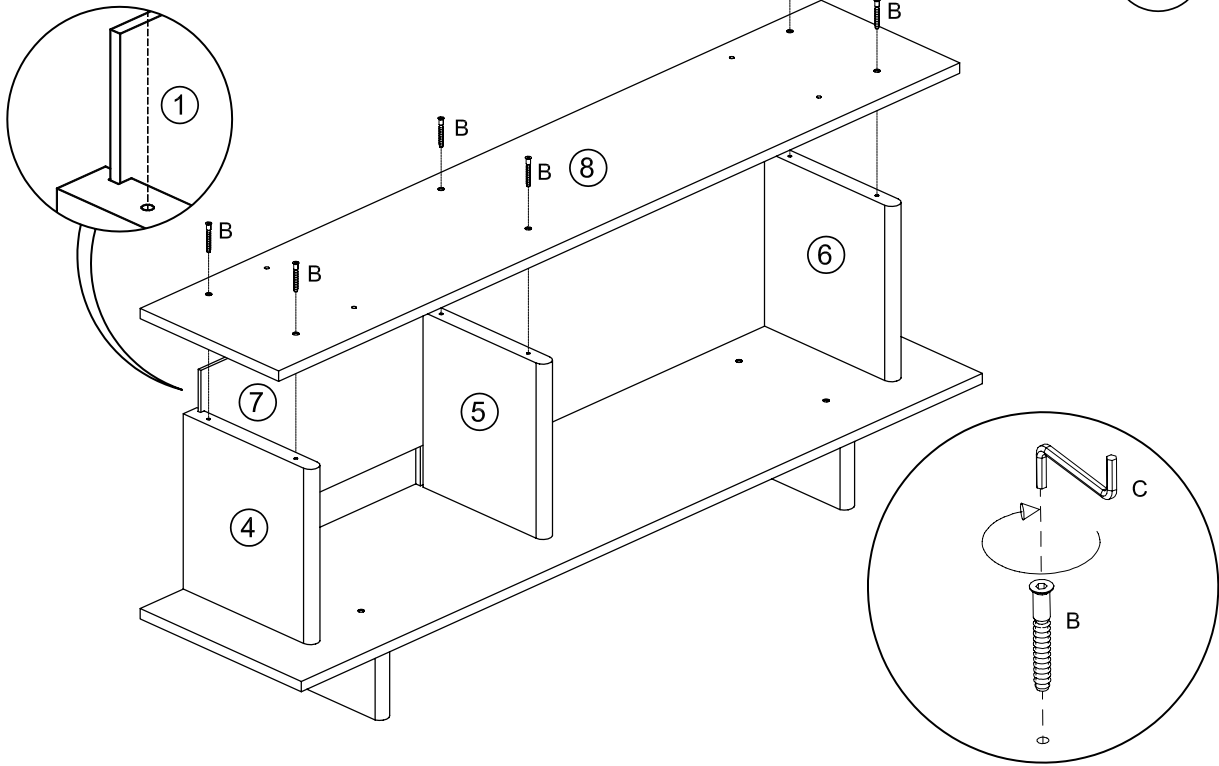

B		Ø7x50	4 pcs
C			1 pc

6

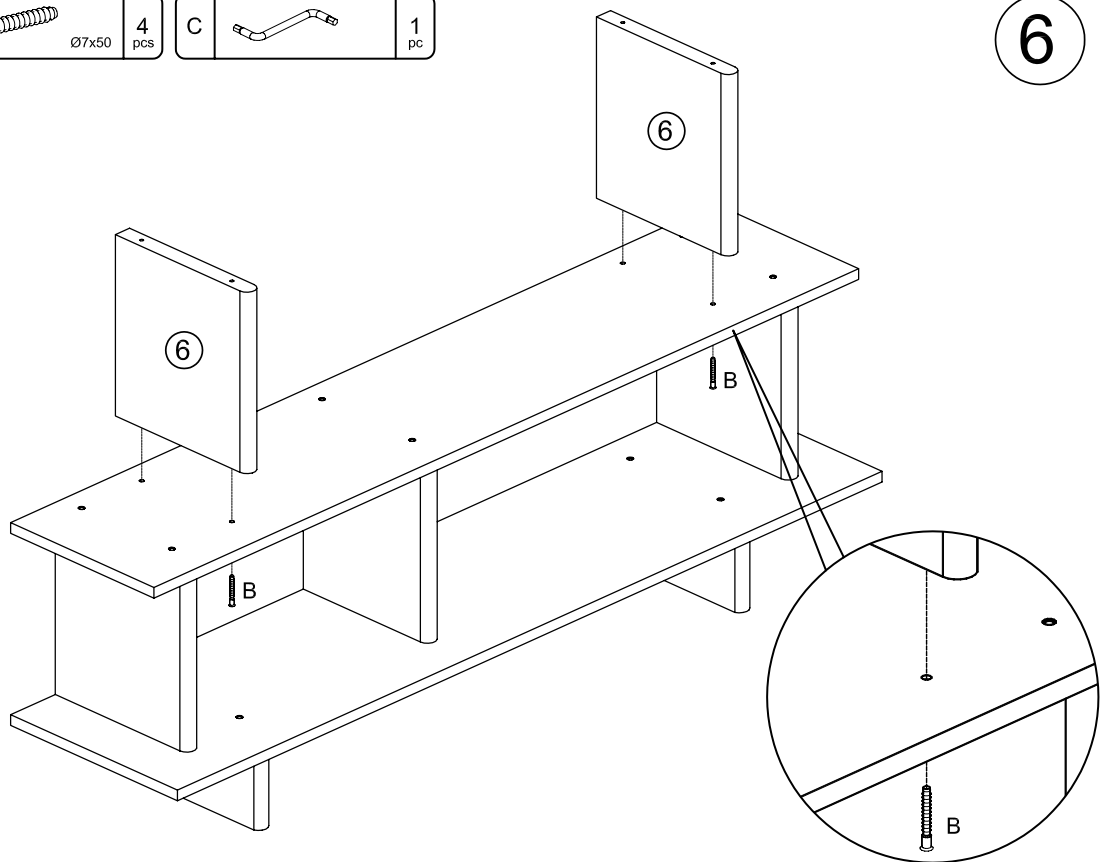



B  Ø7x50 4 pcs

C  1 pc

G  Ø3.5x15 2 pc

H  2 pcs

7

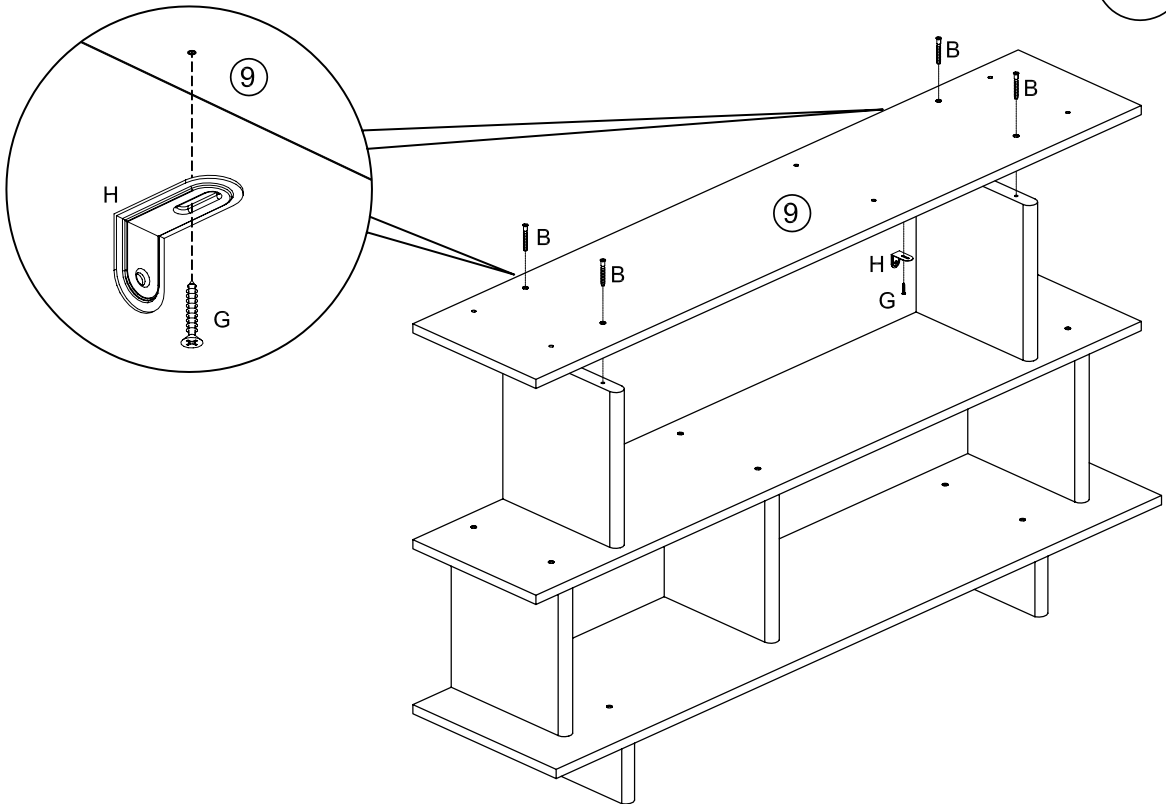

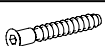
B  Ø7x50 6 pcs

C  1 pc

8

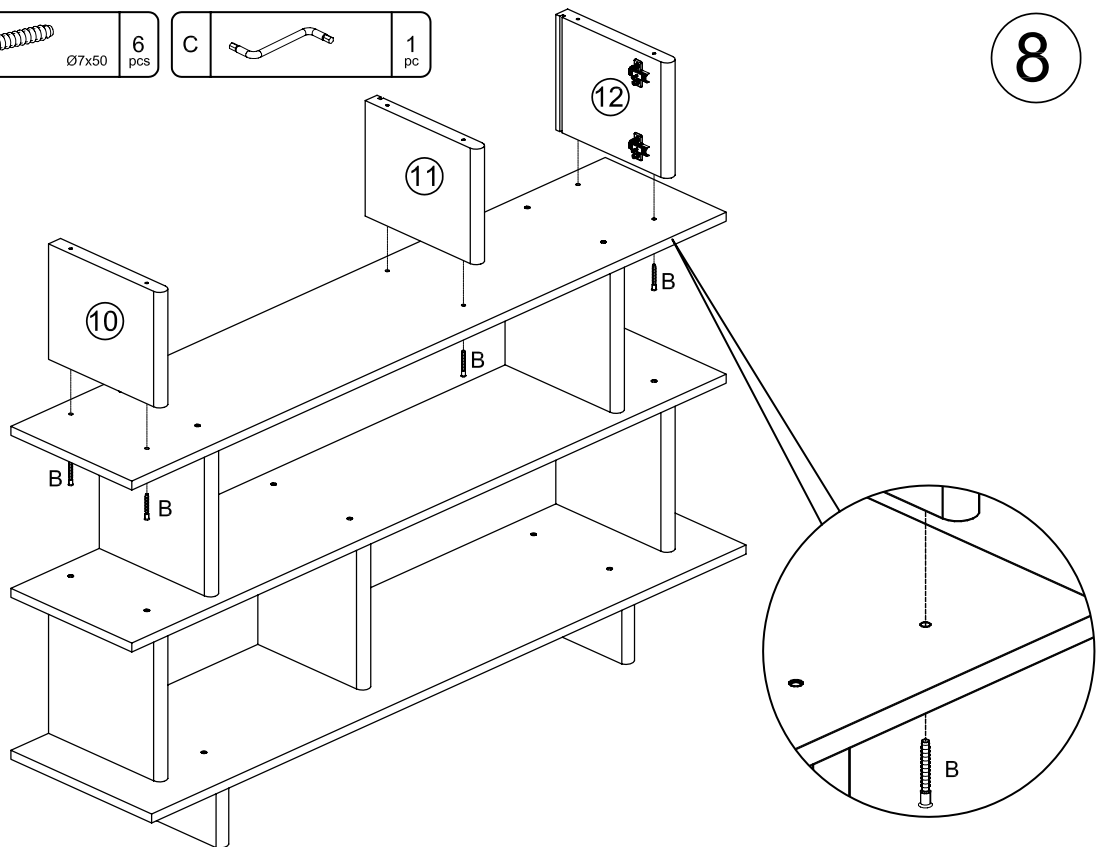

B		6 pcs	Ø7x50
C		1 pc	

9

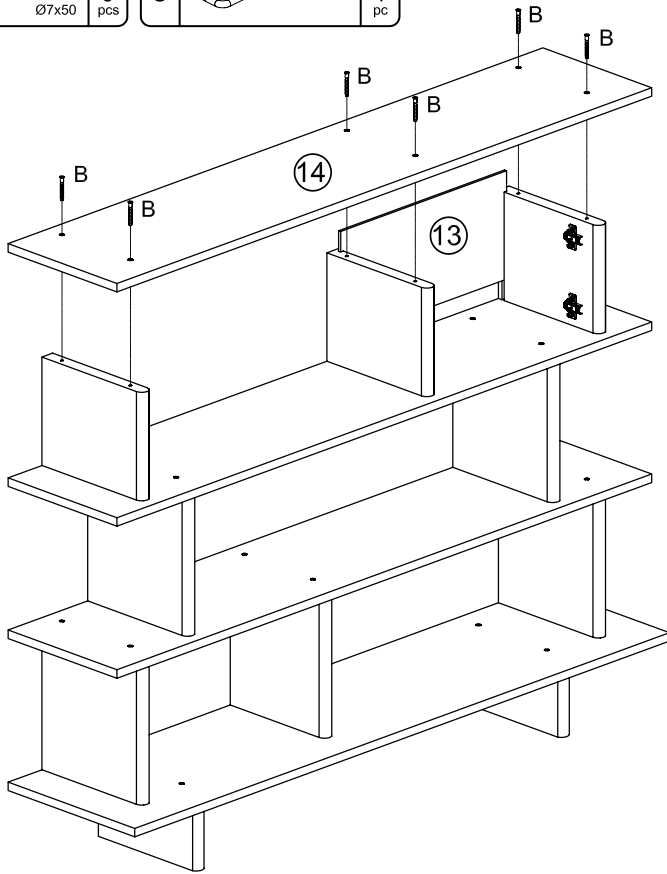

D		4 pcs	
G		8 pcs	Ø3.5x15

10

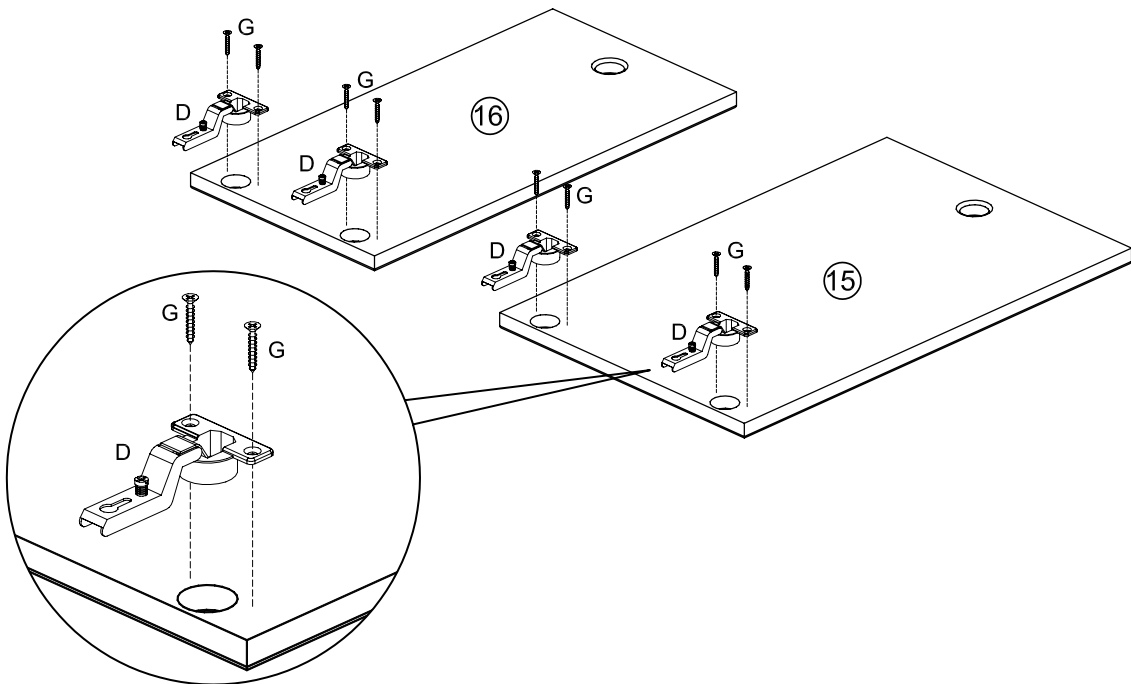

F  2 pcs

11

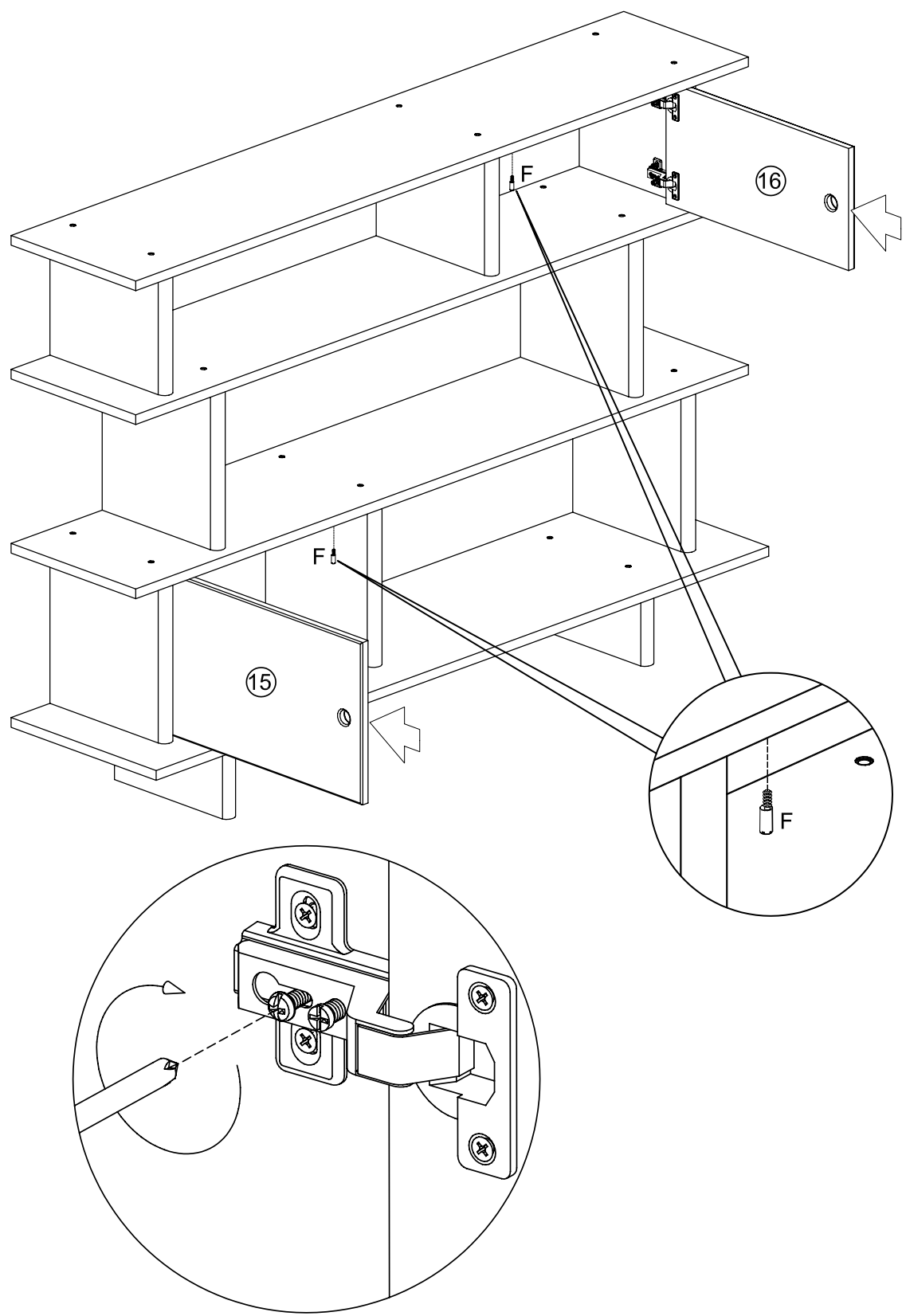

Adjusting a door. Das Richten einer Türe. Réglage d'une porte.

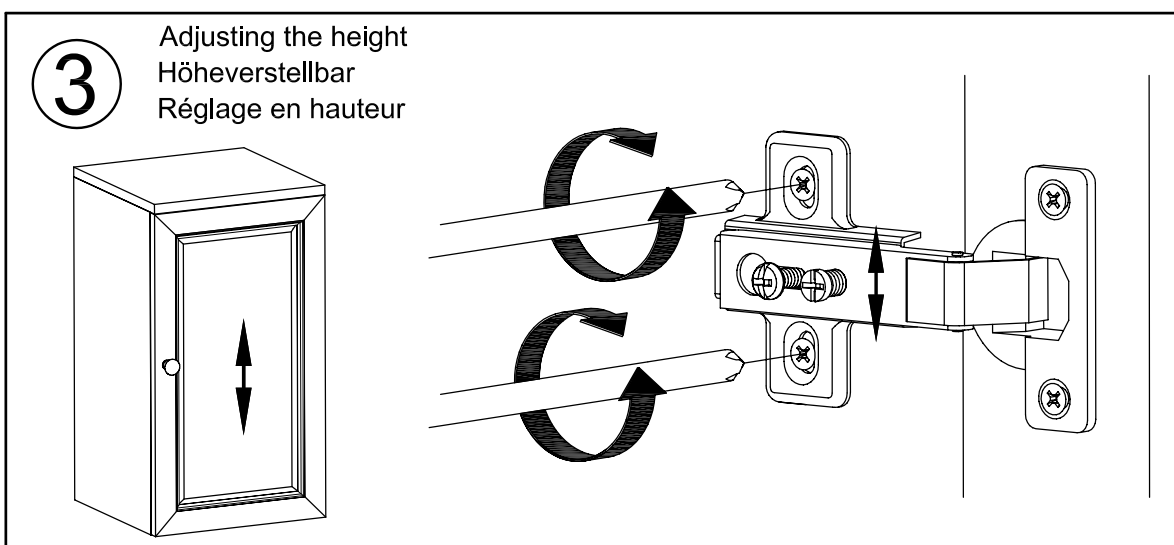
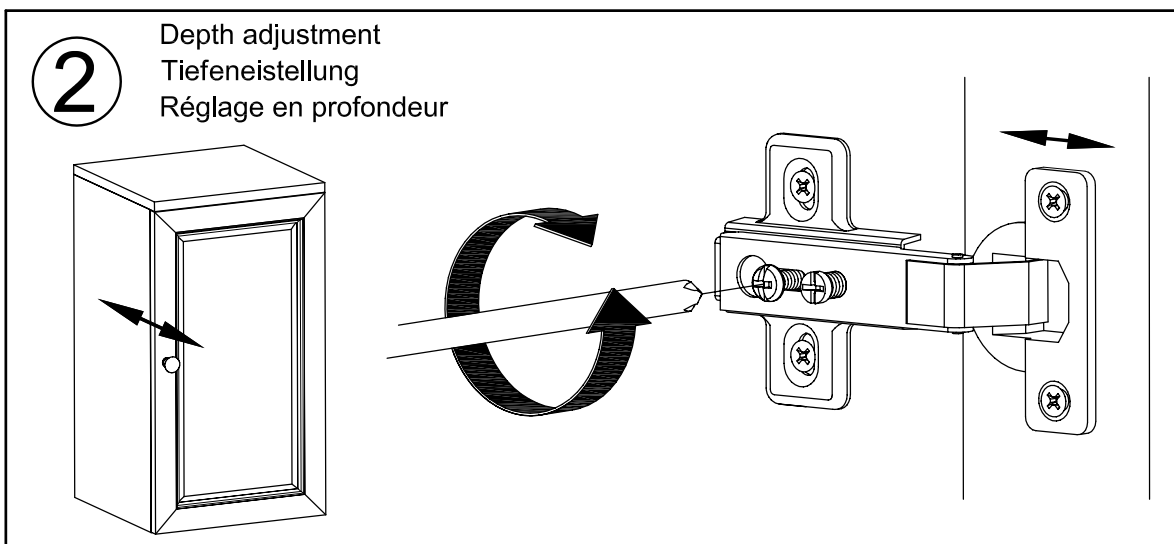
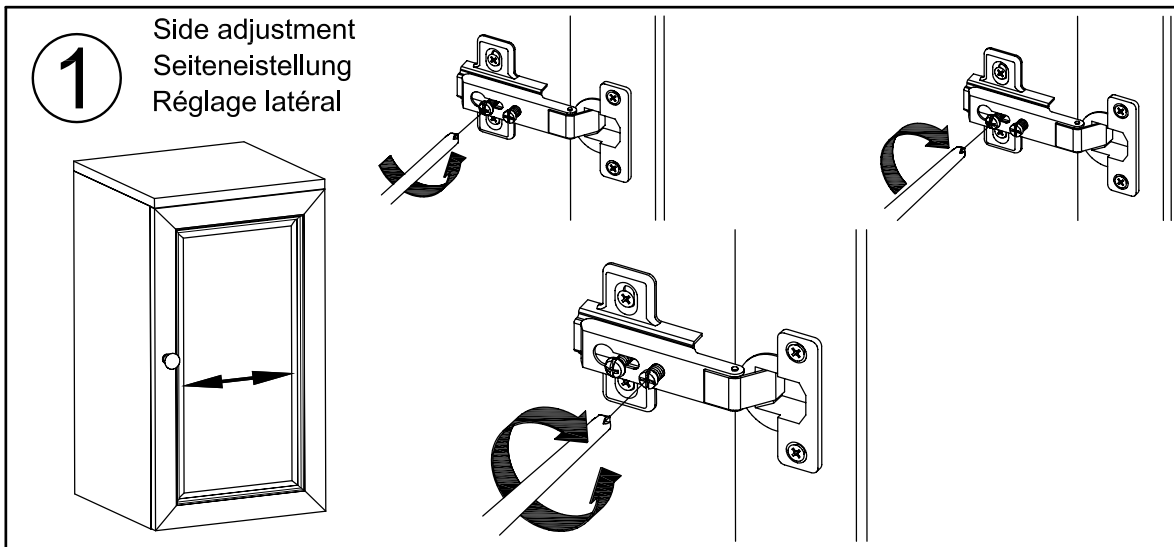

20RE - 01

Wandbefestigung. Fixing to the wall. Fixation an mur.

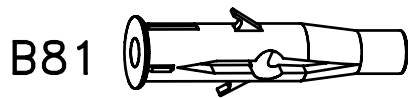

Allrounddübel  
Allround fixings  
Chevilles passe-partout

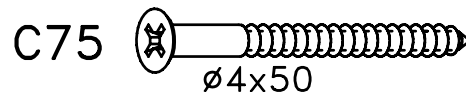

Spanplattenschrauben Senkkopf  
Countersunk screws  
Vis à tête fraisée

 ø8mm

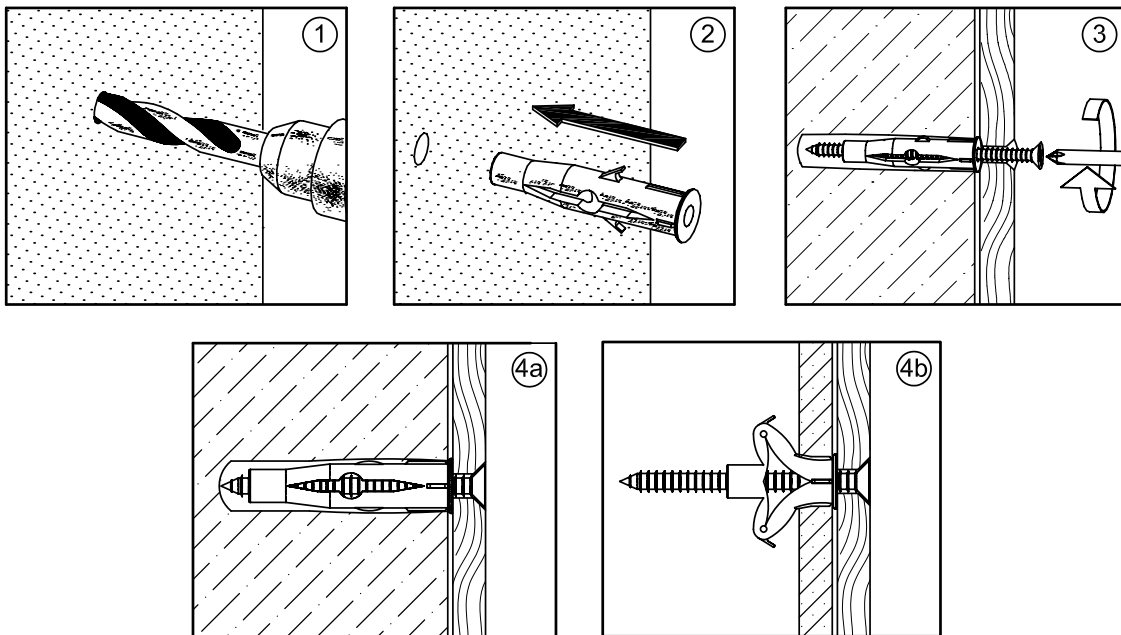

**D** Allrounddübel sind geeignet für :  
Beton - Naturstein - Vollziegel - Kalkstein - Vollstein - Bims-Vollstein -  
Gasbeton=Porenbeton - Vollgipsplatten - Hochlochziegel - Kalksandlochstein -  
Hohlblock - Faserzementplatten - Gipskartonplatten - Spanplatten etc..

**GB** Allround fixings are suitable for :  
Concrete - Natural stone - Solid brick - Solid calcium silicate brick - Pumice-breeze  
block- Aircrete blocks - Solid gypsum panels - Hollow/perforated brick -  
Hollow/perforated calcium silicate brick - Hollow block - Synthetic fibre boards - Gypsum  
board sandwich panel - Chipboards etc..

**F** Chevilles passe-partout pour :  
Béton - Pierre naturelle - Brique pleine - Brique silicocalcaire pleine - Ponce - Béton  
cellulaire - Carreaux de plâtre - Brique creuse - Brique silicocalcaire perforée - Bloc  
creux - Panneaux fibrociment - Plaques de carton plâtre - Panneaux de particules etc..