

# 用户操作手册

Version 1.0 CN

## ● 机翼可折叠

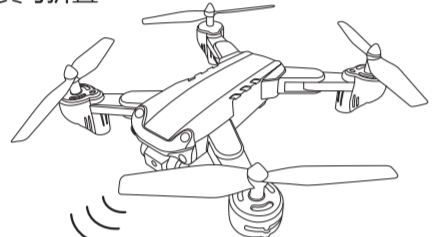

▲ 请务必安装保护架以保护电机和防止误伤他人。

## ● 更换风叶

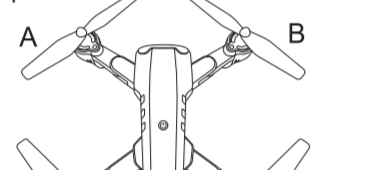

▲ 请确保正确安装，安装错误将导致不能正常飞行。

## ● 遥控器功能说明

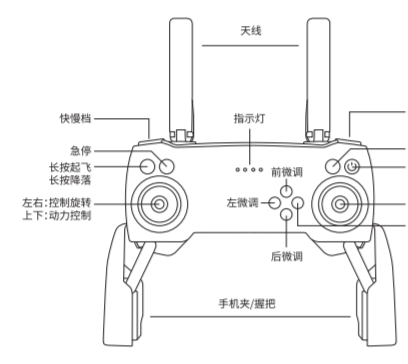

## ● 安装飞行器及遥控器电池

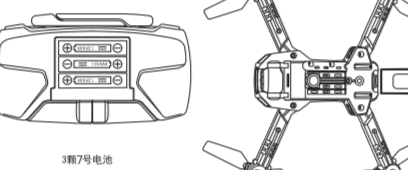

1. 请不要将新旧电池混在一起使用。
2. 请不要将不同类型电池混在一起使用。
3. 当低电压提示时请更换电池。
4. 长时间不用请取出电池。

## ● 飞行器锂电池充电

1. 将电池从飞行器取出。
2. 将电池插入USB充电线中。
3. 将USB充电线插入电脑的USB接口或USB充电线的灯盒。
4. 充电时间大概为120分钟。充满后USB充电线的灯盒熄灭。

提示：当电池充满后请及时将电池从USB充电线取出。红灯亮时：充电中；黄灯亮时：充电完成。

## ● 定高功能介绍

使用定高按钮上下移动可以控制飞行器上升或下降。当上升到一定高度或下降到一定高度时即开始飞行。此时飞行器会保持在当前的高度。

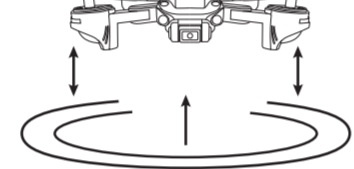

提示：当飞行器停止时定高功能失效。飞行器只会自动起飞，但不会离开地面。定高功能只适用于飞行器起飞后。

## ● 起飞流程

1. 确保飞行器上的电池已充满。
2. 将遥控器、飞行器及遥控器的电池充满。遥控器灯亮代表连接正常。将飞行器置于水平地面。飞行器提示灯闪烁说明飞行器进入配对状态。
3. 长按遥控器上的起飞按钮。遥控器灯亮代表飞行器进入起飞状态。
4. 遥控器与飞行器一开一关后自动配对。如果飞行器上灯亮表示配对成功。
5. 现在你可以推动油门杆来控制飞行器起飞。

## ● 飞行器方向操作

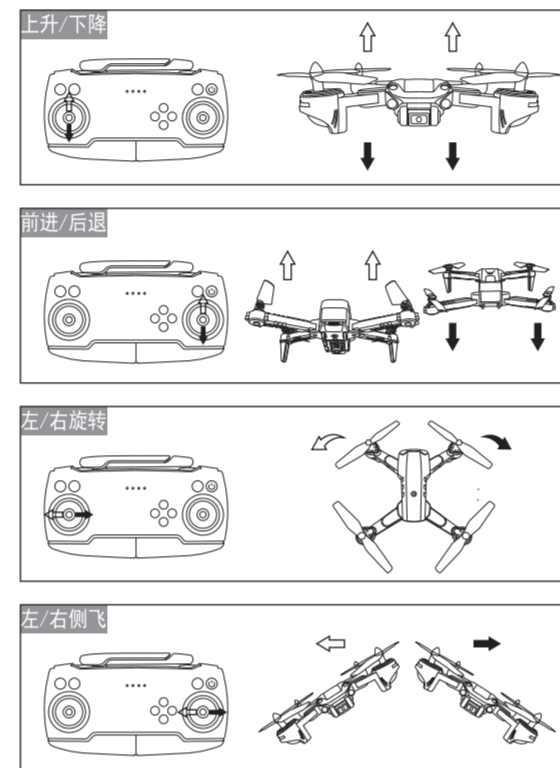

## ● 微调操作

当飞行器在空中时，一直按住方向键可以自由悬停或旋转。可以通过以下操作对飞行器进行微调。

一直向前或向后方向移动

调整方向



## ● 水平校准

当飞行器在空中时，一直按住方向键可以自由悬停或旋转。可以通过以下操作对飞行器进行微调。

一直向前或向后方向移动

调整方向

## ● 3D翻滚

飞行器在空中时可以以360度进行翻滚。按下遥控器上的360度按钮，遥控器会发出“滴”、“滴”、“滴”的声音。这个时候只需要按一下遥控器上的360度按钮，飞行器就会向你所打的方向做360度翻滚。



## ● 无头模式

当飞行器无头模式时，飞行器只会根据遥控器上的方向键来控制飞行。按下遥控器上的“无头模式”按钮，飞行器会自动切换到无头模式。

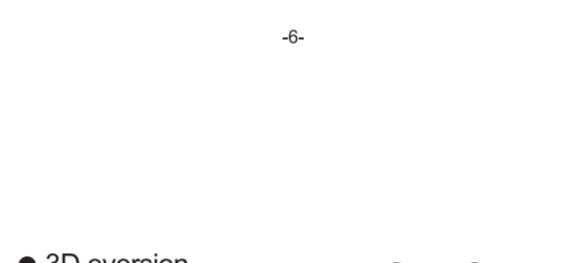

## ● 一键返航

一键返航：飞行器会自动回到起飞位置。按下遥控器上的“一键返航”按钮，飞行器会自动回到起飞位置。

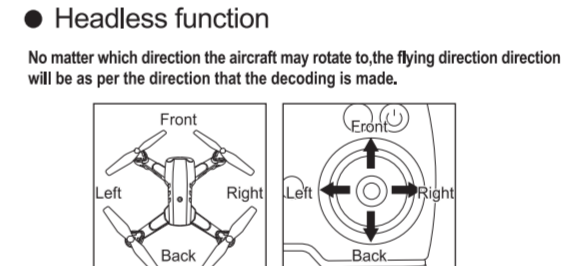

## ● 低电压保护

当飞行器在空中时，如果电池电量过低，飞行器会自动降落。按下遥控器上的“低电压保护”按钮，飞行器会自动降落。

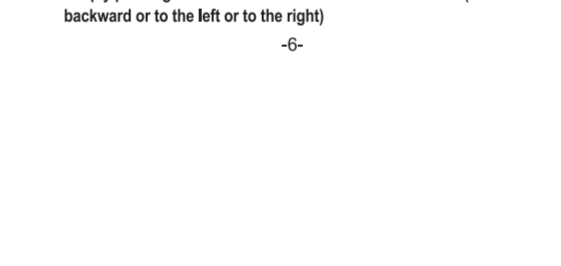

# User Manual

Version 1.0 CN

## ● Folded wing

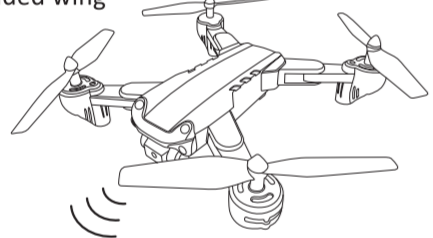

▲ Please install the protector first to protect the motor and prevent injury to others.

## ● Replace rotor blade

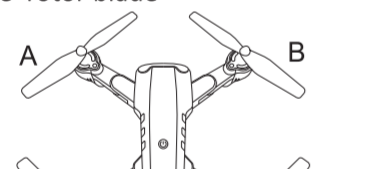

▲ Please make sure that it is installed correctly, otherwise it will not be able to fly normally.

## ● Transmitter

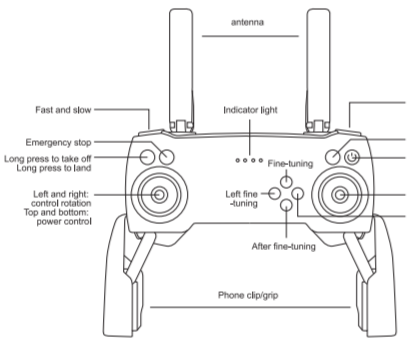

## ● Install battery for aircraft and transmitter

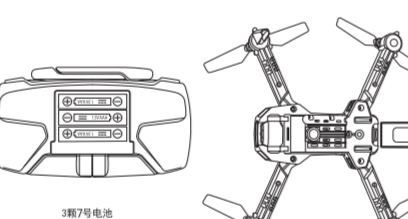

1. Please do not mix old and new batteries together.
2. Please do not mix different types of batteries together.
3. Please replace the battery when the low voltage prompts.
4. Please remove the battery if not used for a long time.

## ● Battery charging

1. Remove the battery from the aircraft.
2. Insert the battery into the USB charging cable.
3. Insert the USB charging cable into the power of the computer USB interface. The red light indicates that the battery is charging.
4. Battery charging time is about 120 minutes. The light out when the battery is complete.

Tip: please remove the battery from the USB charging cable when the battery is charged completely. Light on Charging light out/Complete.

## ● Altitude hold function

After asking the left joystick (Accelerator) to control the ascending/ascending flight of the aircraft free up the left joystick. (Accelerator) and the aircraft will hold level at that height when the joystick is free.



Tip: The first push the left joystick up to start the motor, doesn't makes the aircraft fly. The second push the left joystick up to let the aircraft rise.

## ● Ready to fly you aircraft

1. Make sure the battery on the aircraft is fully charged.
2. After the battery is installed in the aircraft, press the power button on the top. The blue light flashes to indicate that the connection is normal. Place the aircraft on a level ground. The aircraft prompt light flashes to indicate that the aircraft enters the code matching state.
3. After the battery is loaded into the remote control, press the power button, and the blue light flashes to indicate that enters the code matching state.
4. The remote control and the UAV will automatically pair codes with each other as soon as the switch is turned on. If the light on the aircraft is always on, the code setting is completed.
5. Now you can push the power remote control to freely control the aircraft to fly.

## ● Operating direction

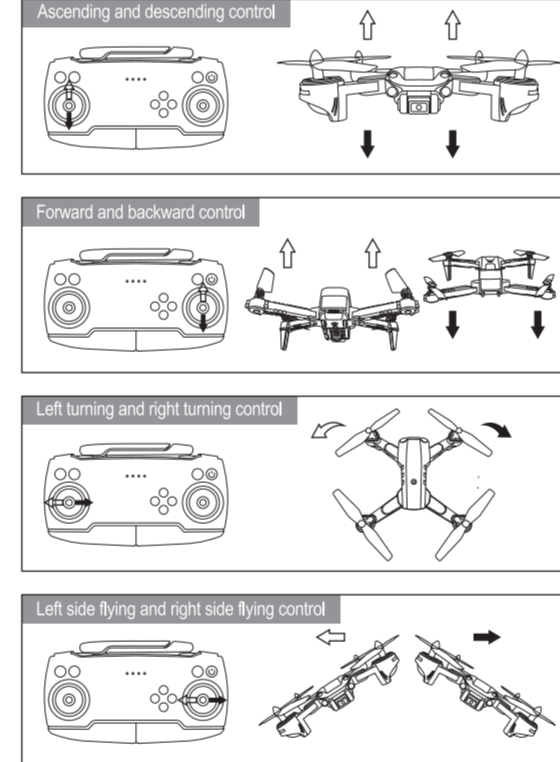

## ● Fine-tuning operation

When the aircraft is hovering in the air, in the event that the aircraft is automatically advancing forward or backward, flying sideward on the left or right, it can be rectified by doing the following.

Forward

Backward

Drift to the left

Drift to the right

flying sideward on the left or right

Corrective Action

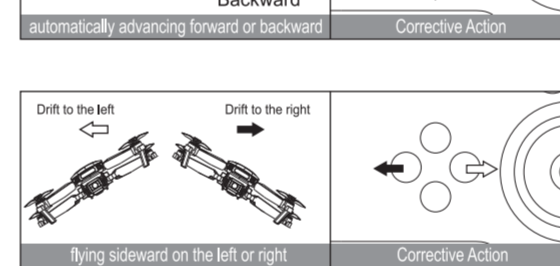

## ● Horizontal calibration

You can use the horizontal calibration function to calibrate the aircraft when it drifts in a certain direction in the air or when it moves on the spot. Put the aircraft on a horizontal surface. Move the direction control lever on the remote control and the remote control emits a beep. At the same time, the blue light of the aircraft flashes. This for about 3 seconds, the blue light of the aircraft is always on, and the calibration is completed.

## ● 3D eversion

When you are familiar with the basic operation, you can do some awesome and exciting tricks and stunts. First of all, fly the aircraft to a height of more than 3 meters, press the 360-degree button on the rear right side of the transmitter, then push the right rudder (in any direction) to make 360-degree flip.

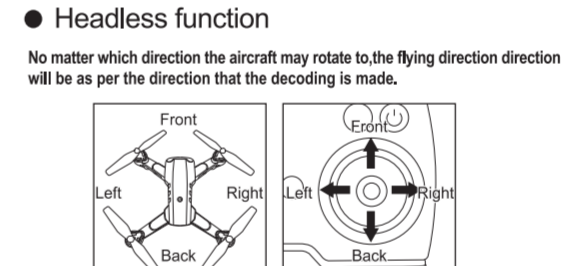

## ● Headless function

No matter which direction the aircraft may rotate to the flying direction direction will be as per the direction that the decending is made.

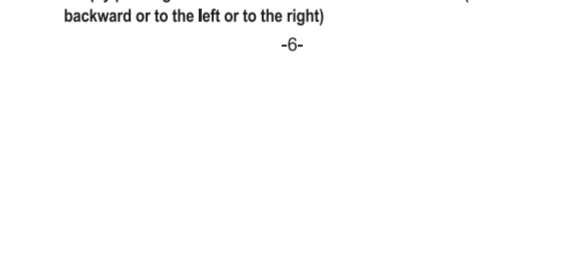

## ● One-key Return

In this mode, the aircraft automatically returns to the location of the operator. Enter One-key Return: Press the button for "One-key Return". Exit One-key Return: 1. Press the button again for "One-key Return". 2. Simply pushing the Direction Lever toward either direction/forward or backward or to the left or to the right.

## ● Low-voltage protection

All lights flashing indicates that the battery is low when the aircraft is flying in the sky. Slow flashing Battery low power. Tip: Aircraft can not be rolled in the case of low power.

## ● One key to rise/down

One key to rise: When the aircraft is on the ground, press the button "One key to rise" on transmitter. At this time the aircraft will automatically rise to a height of 1.5 meters. One key to down: When the aircraft stays in the air, press the descending button in the lower left corner of the remote control, and the aircraft will automatically descend to the ground at this time.

## ● Forced stop

For fixed versions, the aircraft does not stop immediately when the power remote rod is pulled down to the lowest level. As shown in the figure on the right, press the emergency stop button for 2 seconds, and the aircraft will force it to stop. Tip: this operation is very useful in emergency situations.