

MINI PUMP

WEIGHT : 89G
INPUT I/O : 5.0V = 0.8A

PRESSURE : 3.5kPa
FLOW : 180L/MIN
ENDURANCE : 15MIN

BATTERY : 1300mAh

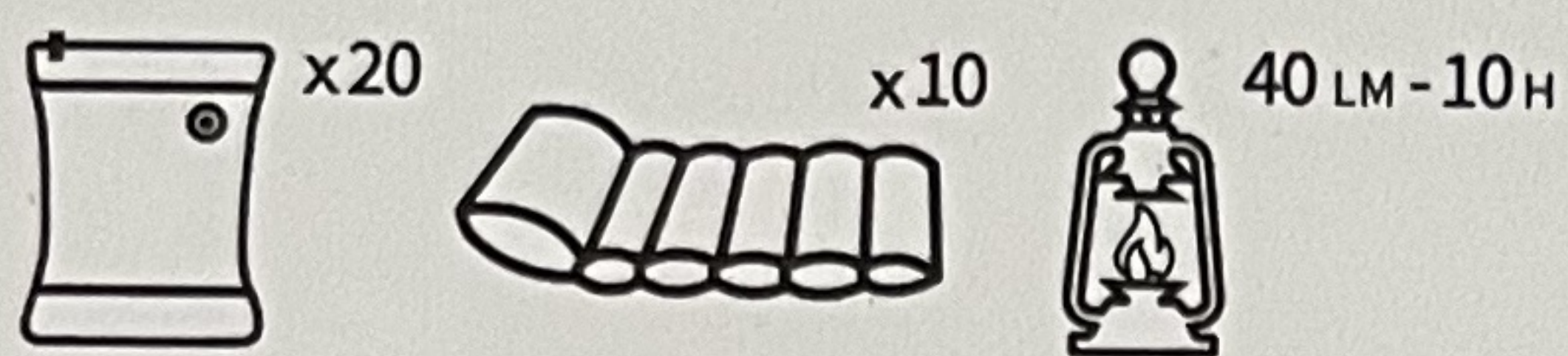

THE NOZZLES

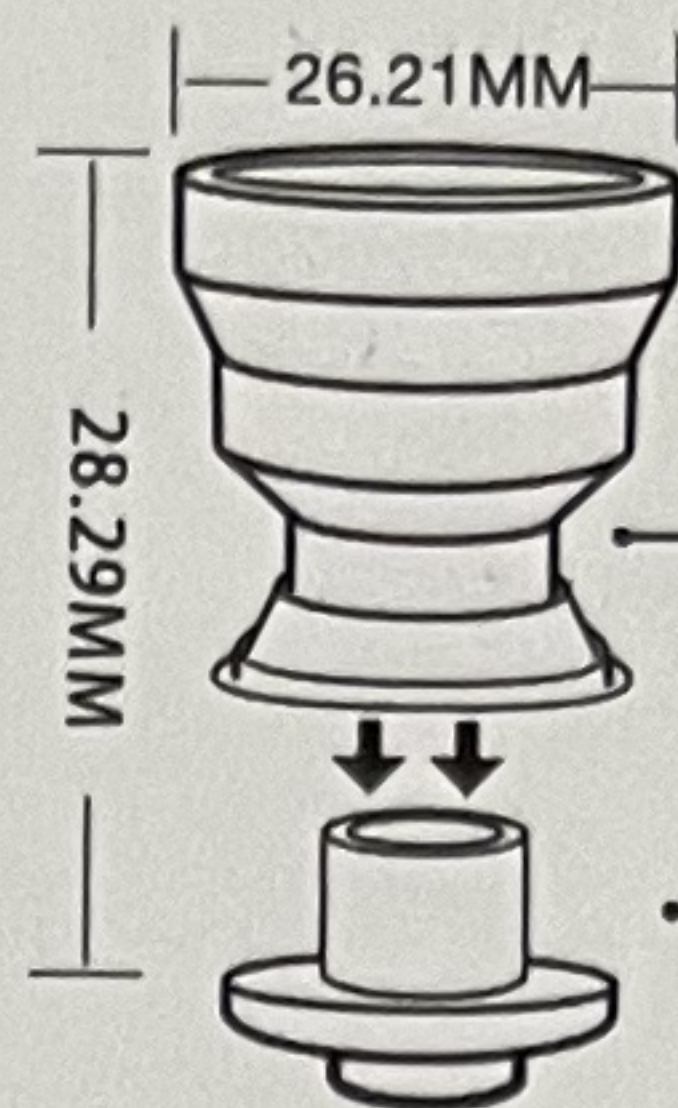

After connection
Fitting outdoor air cushion

Used alone
Fitting inflatable boats

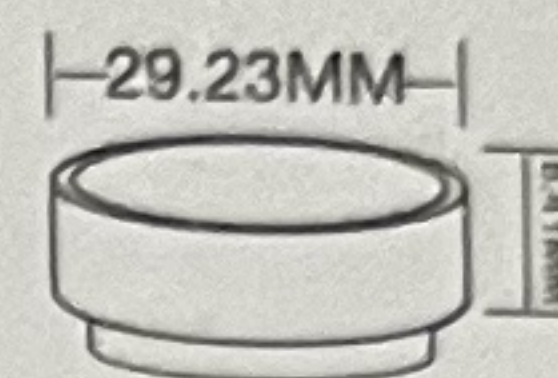

Vacuum storage bag



Air Bed
Floating Bed

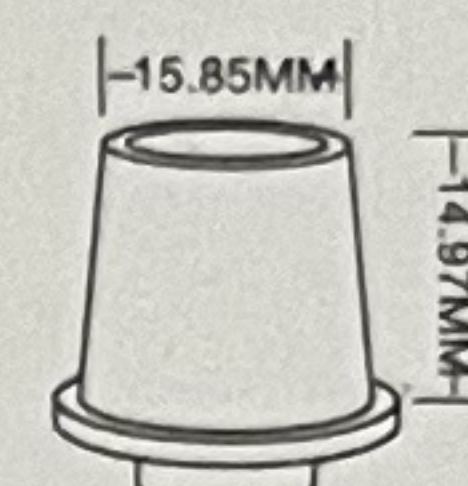

Air Mattress
Air Pillow

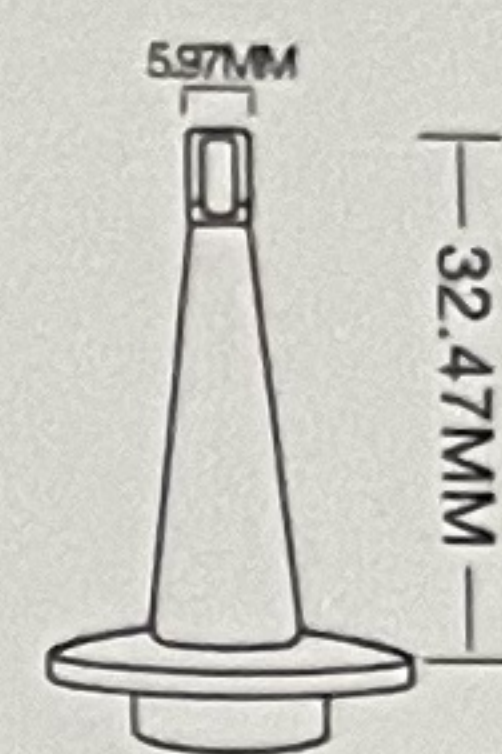

Swimming Ring
Inflatable Toy

INFLATE

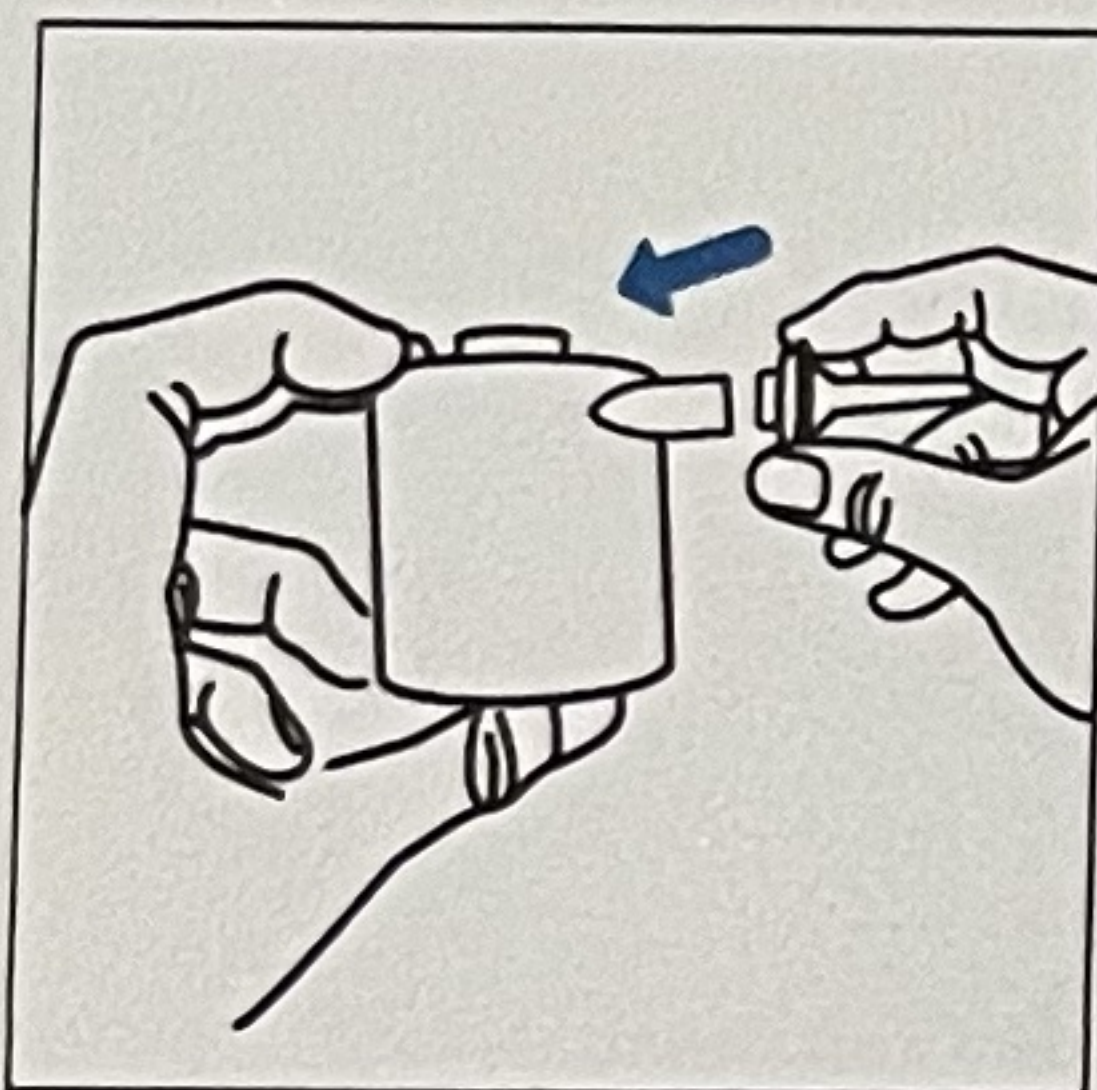

Filling port connect
nozzle

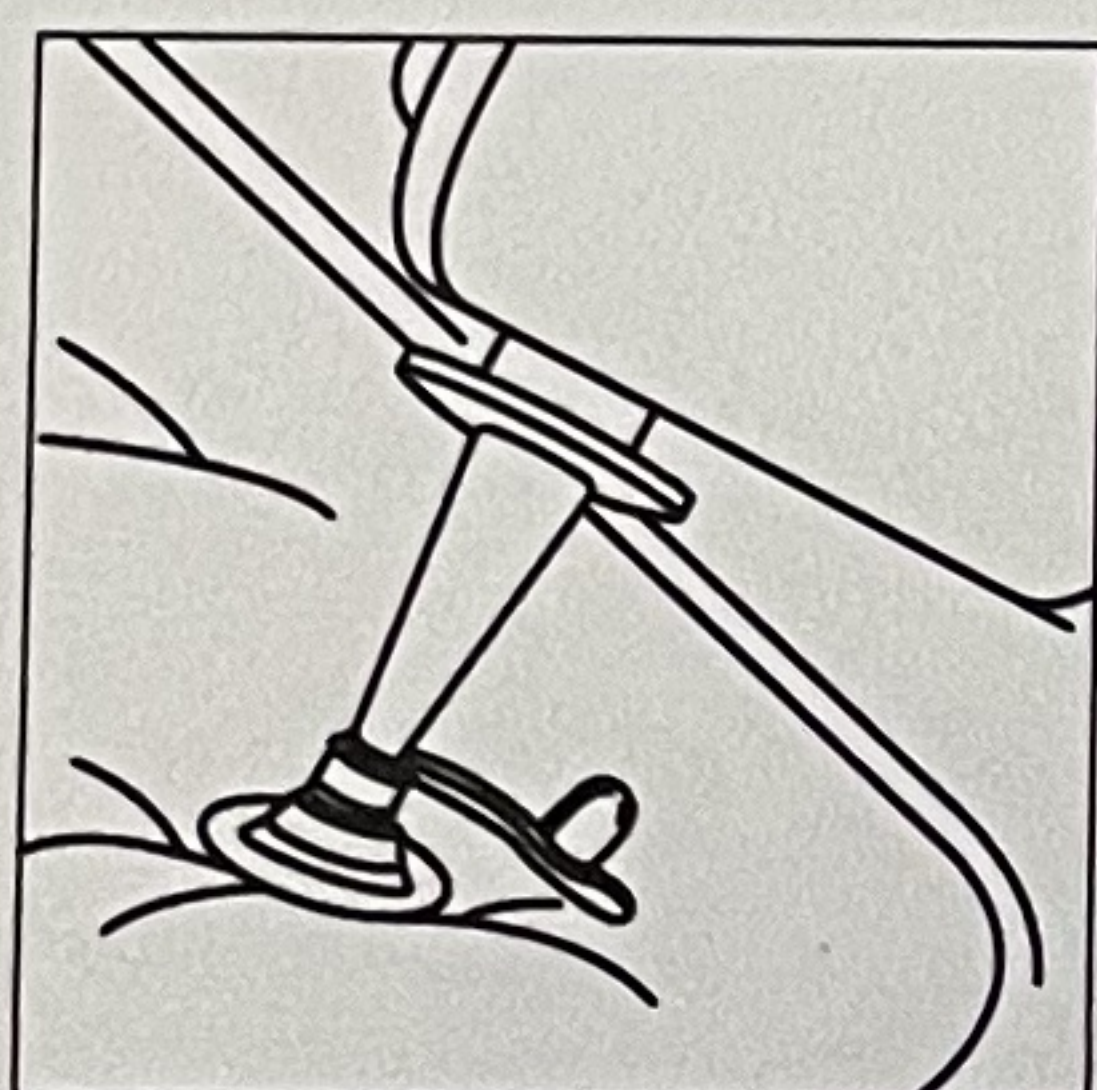

Connect the object
and start filling it full

VACUUM STORAGE

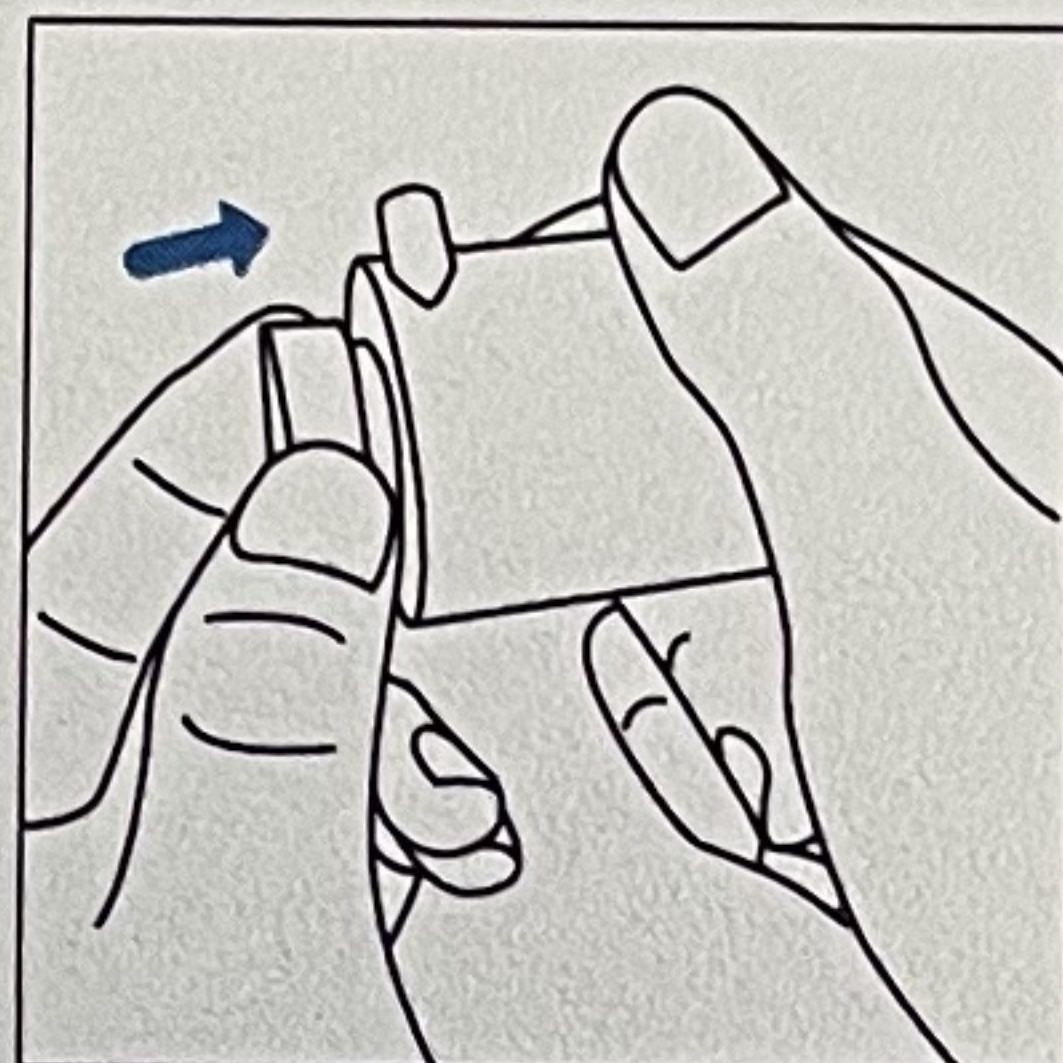

Select vacuum bag
nozzle

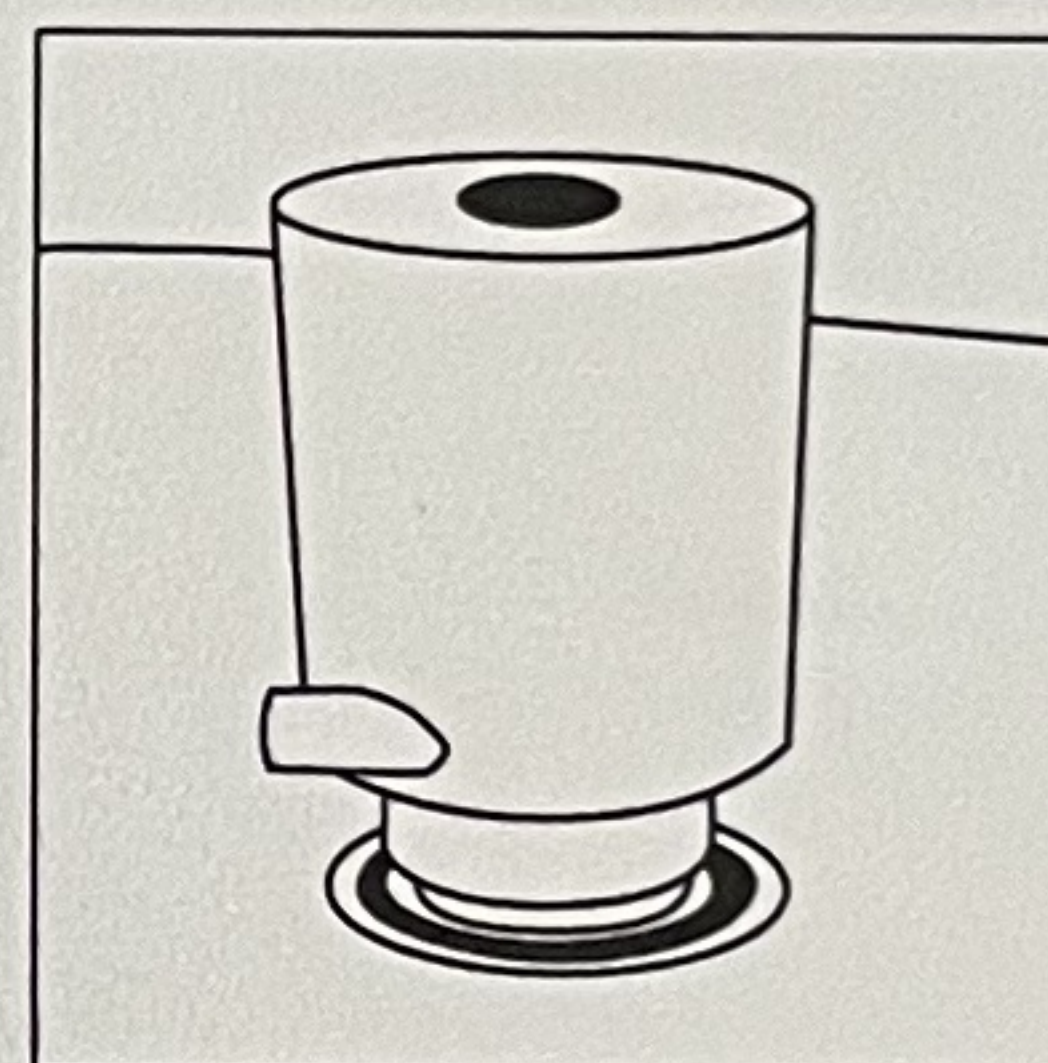

Connect the nozzle
to your Storage bag
and start exhausting
air

CAMPING LANTERN

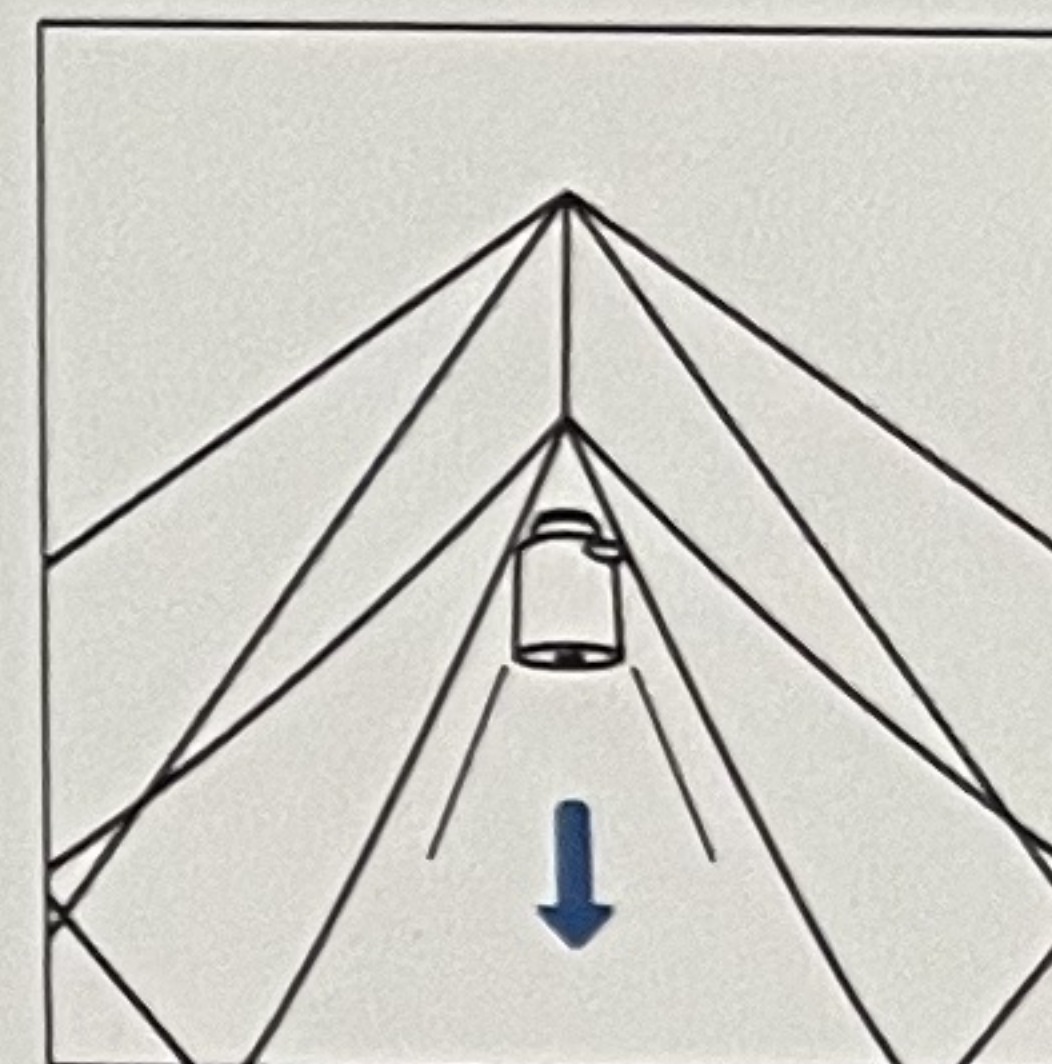

40LM-10H
160LM-2.5H
400LM-1H

LUVEGO

E-GADGET.EU

Spoorlaan 302
5017JZ, Tilburg
Netherlands

www.luvego.nl

FOLLOW US

Luvego

luvego_europe

— LGS3 —