

HP Ethernet 1Gb 4-port 331T Adapter User Guide

Abstract

This document is for the person who installs, administers, and troubleshoots servers and storage systems. HP assumes you are qualified in the servicing of computer equipment and trained in recognizing hazards in products with hazardous energy levels.



Part Number: 669524-001
September 2011
Edition: 1

© Copyright 2011 Hewlett-Packard Development Company, L.P.

The information contained herein is subject to change without notice. The only warranties for HP products and services are set forth in the express warranty statements accompanying such products and services. Nothing herein should be construed as constituting an additional warranty. HP shall not be liable for technical or editorial errors or omissions contained herein.

Microsoft and Windows are U.S. registered trademarks of Microsoft Corporation.

Bluetooth is a trademark owned by its proprietor and used by Hewlett-Packard Company under license.

Contents

Technician notes	4
Warnings, cautions, and notes	4
Downloading files	4
HP contact information.....	5
Introduction	6
Overview	6
UTP CAT5 cable	6
LED indicators.....	6
Installing an adapter	8
Installation overview	8
Preventing electrostatic discharge	8
Installing an adapter in a server.....	9
Installing a low profile bracket.....	9
Connecting the network cable	10
Specifications.....	11
UTP cable specifications	11
General specifications	11
Compliance.....	11
Power and environmental specifications	12
Regulatory compliance notices	13
Regulatory compliance identification numbers	13
Federal Communications Commission Notice.....	13
European Union regulatory notice.....	13
Canadian notice (Avis Canadien).....	14
Korean class B notice	14
Japanese class B notice	14
Disposal of waste equipment by users in private households in the European Union	14
Electrostatic discharge.....	16
Preventing electrostatic discharge	16
Grounding methods to prevent electrostatic discharge.....	16
Acronyms and abbreviations.....	17
Index.....	18

Technician notes

Warnings, cautions, and notes



WARNING: Only authorized technicians trained by HP should attempt to repair this equipment. All troubleshooting and repair procedures are detailed to allow only subassembly/module-level repair. Because of the complexity of the individual boards and subassemblies, no one should attempt to make repairs at the component level or to make modifications to any printed wiring board. Improper repairs can create a safety hazard.



WARNING: To reduce the risk of electric shock, personal injury, and damage to the equipment:

- Do not attempt to service any parts of the equipment other than those specified in the following procedure. Any other activities may require that you shut down the server and remove the power cord.
- Installation and maintenance of this product must be performed by individuals who are knowledgeable about the procedures, precautions and hazards associated with the product.



WARNING: To reduce the risk of electric shock or damage to the equipment:

- Do not disable the power cord grounding plug. The grounding plug is an important safety feature.
- Plug the power cord into a grounded (earthed) electrical outlet that is easily accessible at all times.
- Unplug the power cord from the power supply to disconnect power to the equipment.
- Do not route the power cord where it can be walked on or pinched by items placed against it. Pay particular attention to the plug, electrical outlet, and the point where the cord extends from the server.



This symbol indicates the presence of a hot surface or hot component. If this surface is contacted, the potential for injury exists.

WARNING: To reduce the risk of injury from a hot component, allow the surface to cool before touching.



CAUTION: To properly ventilate the system, you must provide at least 7.6 cm (3.0 in) of clearance at the front and back of the server.



CAUTION: The server is designed to be electrically grounded (earthed). To ensure proper operation, plug the AC power cord into a properly grounded AC outlet only.

NOTE: Any indications of component replacement or printed wiring board modifications may void any warranty.

Downloading files

1. Go to the HP website (<http://www.hp.com/#Support>).

2. Select **Download drivers and software (and firmware)**.
3. Type the adapter name in the **For product** box and then click **Go**. For example, type HP Ethernet 1Gb 4-port 331T.
4. Download the drivers, firmware, or documentation as needed.

HP contact information

For United States and worldwide contact information, see the Contact HP website (<http://www.hp.com/go/assistance>).

In the United States:

- To contact HP by phone, call 1-800-334-5144. For continuous quality improvement, calls may be recorded or monitored.
- If you have purchased a Care Pack (service upgrade), see the Support & Drivers website (<http://www8.hp.com/us/en/support-drivers.html>). If the problem cannot be resolved at the website, call 1-800-633-3600. For more information about Care Packs, see the HP website (<http://pro-aq-sama.houston.hp.com/services/cache/10950-0-0-225-121.html>).

Introduction

Overview

The HP Ethernet 1Gb 4-port 331T Adapter is a four port, 10/100/1000BASE-T Ethernet adapter. The HP Ethernet 1Gb 4-port 331T Adapter is field replaceable and features Energy Efficient Ethernet and IEEE 1588/Precision Time Protocol support, PCI Express v2.0, and a sea of sensors that allows temperature monitoring of the option for optimized server power consumption.

For more information about the HP Ethernet 1Gb 4-port 331T Adapter, see the HP website (<http://www.hp.com/go/proliantnics>).

UTP CAT5 cable

The HP Ethernet 1Gb 4-port 331T adapter can use existing UTP CAT5 (or better) cable to deliver Gigabit Ethernet over copper, according to the IEEE 802.3ab specifications. For new installations, CAT5e (enhanced CAT5) cable is recommended.

For troubleshooting and other information about cabling, see UTP Cable Specifications (on page 11).

LED indicators

The HP Ethernet 1Gb 4-port 331T Adapter has four ports with LED indicators for Link (L) and Activity (A) for each port. A standard-height bracket is shown below with RJ-45 ports and LED indicators.

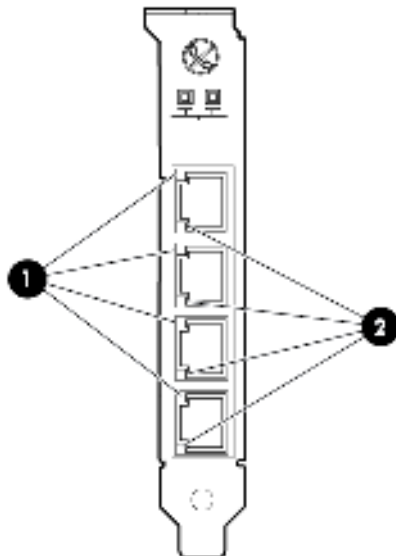

The HP Ethernet 1Gb 4-port 331T Adapter LED indicators operate as described in the following table.

Item	LED indicator	Status	Description
1	Link	Off	No link to the adapter is established. The adapter is not

Item	LED indicator	Status	Description
			receiving power or the cable connection is faulty.
		On (Yellow)	Link to the adapter is established at 10 Mb/s or 100 Mb/s. The adapter is receiving power and the cable connection is good.
		On (Green)	Link to the adapter is established at 1 Gb/s. The adapter is receiving power and the cable connection is good.
2	Activity	Off	Indicates no network activity on the link.
		Flashing (Green)	Indicates network activity on the link. The adapter is sending or receiving network data at up to 1 Gb/s.

Installing an adapter

Installation overview

This section describes installation precautions, how to install the adapter, and how to connect the network cable.



WARNING: To reduce the risk of personal injury or damage to the equipment, consult the safety information and user documentation provided with the server before attempting the installation. Many servers are capable of providing energy levels that are considered hazardous and are intended to be serviced only by qualified personnel who have been trained to deal with these hazards. Do not remove enclosures or attempt to bypass any interlocks that may be provided for the purpose of removing these hazardous conditions.



WARNING: Installation of this adapter should be performed by individuals who are both qualified in the servicing of computer equipment, and trained in the hazards associated with products capable of producing hazardous energy levels. This adapter is intended to be installed in Certified (UL or CSA) ITE equipment having instructions for adding and removing user installed components such as PCI, PCI-X, and PCI Express devices. Refer to the equipment instructions to verify that it is suitable for user installed components and that it has the power capacity to support all of the installed components.

NOTE: Before removing the cover of your server, refer to the HP documentation for the proper methods for installing a PCI Express card and avoiding electric shock hazards.

Preventing electrostatic discharge

To prevent damaging the system, be aware of the precautions you need to follow when setting up the system or handling parts. A discharge of static electricity from a finger or other conductor may damage system boards or other static-sensitive devices. This type of damage may reduce the life expectancy of the device.

To prevent electrostatic damage:

- Avoid hand contact by transporting and storing products in static-safe containers.
- Keep electrostatic-sensitive parts in their containers until they arrive at static-free workstations.
- Place parts on a grounded surface before removing them from their containers.
- Avoid touching pins, leads, or circuitry.
- Always be properly grounded when touching a static-sensitive component or assembly.

Installing an adapter in a server

For additional information on how to safely install a PCI Express card in the server, see the HP ProLiant server documentation.

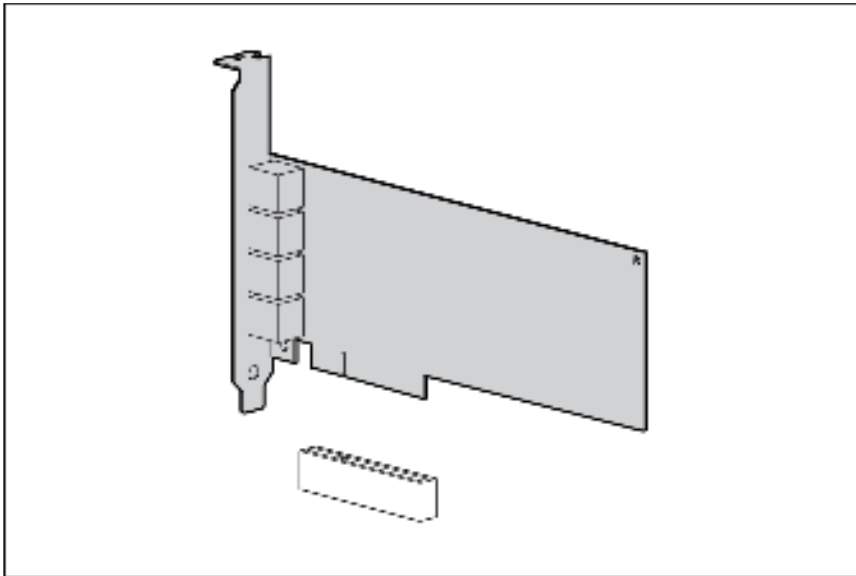

CAUTION: If the server is not PCI Hot Plug compliant, power it down and unplug the power cord from the power outlet before removing the server access panel. Failure to do so may damage the adapter or server.

1. Power down the server.
2. Remove the power cord and server access panel.



WARNING: To reduce the risk of personal injury from a hot component, allow the surface of the option card to cool before touching it.



WARNING: To reduce the risk of personal injury from hot surfaces, allow the drives and the internal system components to cool before touching them.

3. Identify the PCI Express option slot in which the adapter is to be installed. If a low profile option slot is to be used, install the low profile bracket onto the adapter.
4. Remove the cover bracket from the PCI Express slot.
5. Firmly seat the adapter in the PCI Express slot and secure the adapter bracket.

NOTE: For 1U type servers you may need to replace the standard profile bracket with a low profile bracket. See [Installing a low profile bracket \(on page 9\)](#).

6. Replace the access panel and plug in the power cord.

Installing a low profile bracket

You may have to install a low profile bracket to complete the product installation. The low profile bracket replaces the existing standard profile bracket shipped on the product.

To install a low profile bracket:

1. Using a correctly sized slotted screwdriver, carefully remove the two board lock screws located at the top and bottom of the connector.
2. Remove the standard profile bracket and place the low profile bracket over the connector. Be careful not to damage the connector or bind the low profile bracket to the connector.

Connecting the network cable

To secure the cable, plug the cable connector into the RJ-45 port. Ensure that the tab on the plug clicks into position indicating that it is properly seated.

For more information, see UTP cable specifications (on page [11](#)).

Specifications

UTP cable specifications

The HP Ethernet 1Gb 4-port 331T adapter can use existing UTP CAT5 (or better) cable to deliver Gigabit Ethernet over copper, according to the IEEE 802.3ab specifications. For new installations, CAT5e (enhanced CAT5) cable is recommended.

Maximum distances for Gigabit over copper cable are 100 meters (328 feet).

To connect to the network, the HP Ethernet 1Gb 4-port 331T uses the following cable for 1000Base-T transmission:

- CAT5 UTP or better twisted-pair
- 22-26 AWG, 100Ω @ 1 MHz
- EIA/TIA 568a or EIA/TIA 568b

General specifications

Specification	Value
Controller	Broadcom 5719
Data rate	1 Gb/s per port, 4 Gb/s combined, full-duplex
PCI bus	4 Lane (x4) PCI Express Gen 2
Connectors	4 RJ-45
Dimensions (LxW)	5.2 x 2.7 inches (13.208 cm x 6.89 cm) without bracket

Compliance

Compliance	Standard
IEEE	IEEE802.3x, IEEE802.1ax, IEEE802.1p, IEEE802.1q, IEEE802.3az, IEEE1588, IEEE802.1as
Safety	UL Mark (US and Canada) EN 60950
Other	PCIe v2.0 RoHS 6 of 6 IPv4, IPv6 CE Microsoft Windows Hardware Quality Labs Server Design Guide version 3.0 SNMP IPv4, TCP and UDP Checksum Offload IPv4/IPv6 TCP, Large Send Offload Receive-Side Scaling Jumbo Frames up to 9000 Bytes

Power and environmental specifications

Specification	Value
Operating	Temperature—0° to 55° C (0° to 131° F) Humidity—15 to 80% relative humidity, non-condensing
Non-operating	Temperature—40° to 70° C (0° to 158° F) Humidity—10 to 90% relative humidity, non-condensing
Power	4 W typical, 5 W maximum

Regulatory compliance notices

Regulatory compliance identification numbers

For the purpose of regulatory compliance certifications and identification, this product has been assigned a unique regulatory model number. The regulatory model number can be found on the product nameplate label, along with all required approval markings and information. When requesting compliance information for this product, always refer to this regulatory model number. The regulatory model number is not the marketing name or model number of the product.

Federal Communications Commission Notice

This equipment has been tested and found to comply with the limits for a Class B digital device, pursuant to Part 15 of the FCC Rules. These limits are designed to provide reasonable protection against harmful interference in a residential installation. This equipment generates, uses, and can radiate radio frequency energy and, if not installed and used in accordance with the instructions, may cause harmful interference to radio communications. However, there is no guarantee that interference will not occur in a particular installation. If this equipment does cause harmful interference to radio or television reception, which can be determined by turning the equipment off and on, the user is encouraged to try to correct the interference by one or more of the following measures:

- Reorient or relocate the receiving antenna.
- Increase the separation between the equipment and receiver.
- Connect the equipment into an outlet on a circuit that is different from that to which the receiver is connected.
- Consult the dealer or an experienced radio or television technician for help.

European Union regulatory notice

Products bearing the CE marking comply with the following EU Directives:

- Low Voltage Directive 2006/95/EC
- EMC Directive 2004/108/EC
- Ecodesign Directive 2009/125/EC, where applicable

CE compliance of this product is valid if powered with the correct CE-marked AC adapter provided by HP.

Compliance with these directives implies conformity to applicable harmonized European standards (European Norms) that are listed in the EU Declaration of Conformity issued by HP for this product or product family and available (in English only) either within the product documentation or at the following HP website (<http://www.hp.eu/certificates>) (type the product number in the search field).

The compliance is indicated by one of the following conformity markings placed on the product:

For non-telecommunications products and for EU harmonized telecommunications products, such as Bluetooth® within power class below 10mW.



For EU non-harmonized telecommunications products (If applicable, a 4-digit notified body number is inserted between CE and !).



Please refer to the regulatory label provided on the product.

The point of contact for regulatory matters is Hewlett-Packard GmbH, Dept./MS: HQ-TRE, Herrenberger Strasse 140, 71034 Boeblingen, GERMANY.

Canadian notice (Avis Canadien)

This Class B digital apparatus meets all requirements of the Canadian Interference-Causing Equipment Regulations.

Cet appareil numérique de la classe B respecte toutes les exigences du Règlement sur le matériel brouilleur du Canada.

Korean class B notice

B급 기기 (가정용 방송통신기기)	이 기기는 가정용(B급)으로 전자파적합등록을 한 기기로서 주로 가정에서 사용하는 것을 목적으로 하며, 모든 지역에서 사용할 수 있습니다.
-----------------------	--

Japanese class B notice

この装置は、クラスB情報技術装置です。この装置は、家庭環境で使用することを目的としていますが、この装置がラジオやテレビジョン受信機に近接して使用されると、受信障害を引き起こすことがあります。

取扱説明書に従って正しい取り扱いをして下さい。 VCCI-B

Disposal of waste equipment by users in private households in the European Union



This symbol on the product or on its packaging indicates that this product must not be disposed of with your other household waste. Instead, it is your responsibility to dispose of your waste equipment by handing it over to a designated collection point for the recycling of waste electrical and electronic equipment. The separate collection and recycling of your waste equipment at the time of disposal will help to conserve natural resources and ensure that it is recycled in a manner that protects human health and the environment. For more information about where you can drop off your waste equipment for recycling, please contact your local city office, your household waste disposal service or the shop where you purchased the product.

Electrostatic discharge

Preventing electrostatic discharge

To prevent damaging the system, be aware of the precautions you need to follow when setting up the system or handling parts. A discharge of static electricity from a finger or other conductor may damage system boards or other static-sensitive devices. This type of damage may reduce the life expectancy of the device.

To prevent electrostatic damage:

- Avoid hand contact by transporting and storing products in static-safe containers.
- Keep electrostatic-sensitive parts in their containers until they arrive at static-free workstations.
- Place parts on a grounded surface before removing them from their containers.
- Avoid touching pins, leads, or circuitry.
- Always be properly grounded when touching a static-sensitive component or assembly.

Grounding methods to prevent electrostatic discharge

Several methods are used for grounding. Use one or more of the following methods when handling or installing electrostatic-sensitive parts:

- Use a wrist strap connected by a ground cord to a grounded workstation or computer chassis. Wrist straps are flexible straps with a minimum of 1 megohm \pm 10 percent resistance in the ground cords. To provide proper ground, wear the strap snug against the skin.
- Use heel straps, toe straps, or boot straps at standing workstations. Wear the straps on both feet when standing on conductive floors or dissipating floor mats.
- Use conductive field service tools.
- Use a portable field service kit with a folding static-dissipating work mat.

If you do not have any of the suggested equipment for proper grounding, have an authorized reseller install the part.

For more information on static electricity or assistance with product installation, contact an authorized reseller.

Acronyms and abbreviations

CSA

Canadian Standards Association

IEEE

Institute of Electrical and Electronics Engineers

IPv4

Internet Protocol version 4

IPv6

Internet Protocol version 6

LED

light-emitting diode

PCI

peripheral component interface

PCI-X

peripheral component interconnect extended

SNMP

Simple Network Management Protocol

TCP

Transmission Control Protocol

UTP

unshielded twisted pair

Index

A

adapter LEDs 6
adapters 6

B

bracket, low profile 9

C

cable configuration 11
cable connectors 11
cables, networking 10
compliance 11, 13
contact information 5

D

disposal, waste 14
downloading files 4, 5

E

electrostatic discharge 8, 16
environmental specifications 12

F

features 6

G

grounding methods 16

I

installation overview 8
installing adapters 9

L

LEDs 6

N

network cable 6, 10, 11

P

PCI (peripheral component interface) 8, 9
power specifications 12

R

regulatory compliance notices 13, 14

S

specifications 11, 12
standards 13

T

technical notes 4

U

UTP CAT5 cable 11

V

ventilation 4

W

warnings 4